The background of the cover is a decorative diamond lattice pattern. Each diamond contains a circular motif with concentric lines, resembling a stylized eye or a decorative seal. The pattern is printed in a dark color on a light, textured background.

BAXENDALE

& COMPANY LIMITED

PLUMBING

AND

SANITARY

CATALOGUE

E

WE regret that at the date of publication of this catalogue it has been found impossible to include a price list because of the constantly fluctuating costs of commodities.

We hope, nevertheless, that the contents will be a valuable source of information, and it is our intention to publish a price list as soon as this is practicable.

Baxendale and Co. Limited

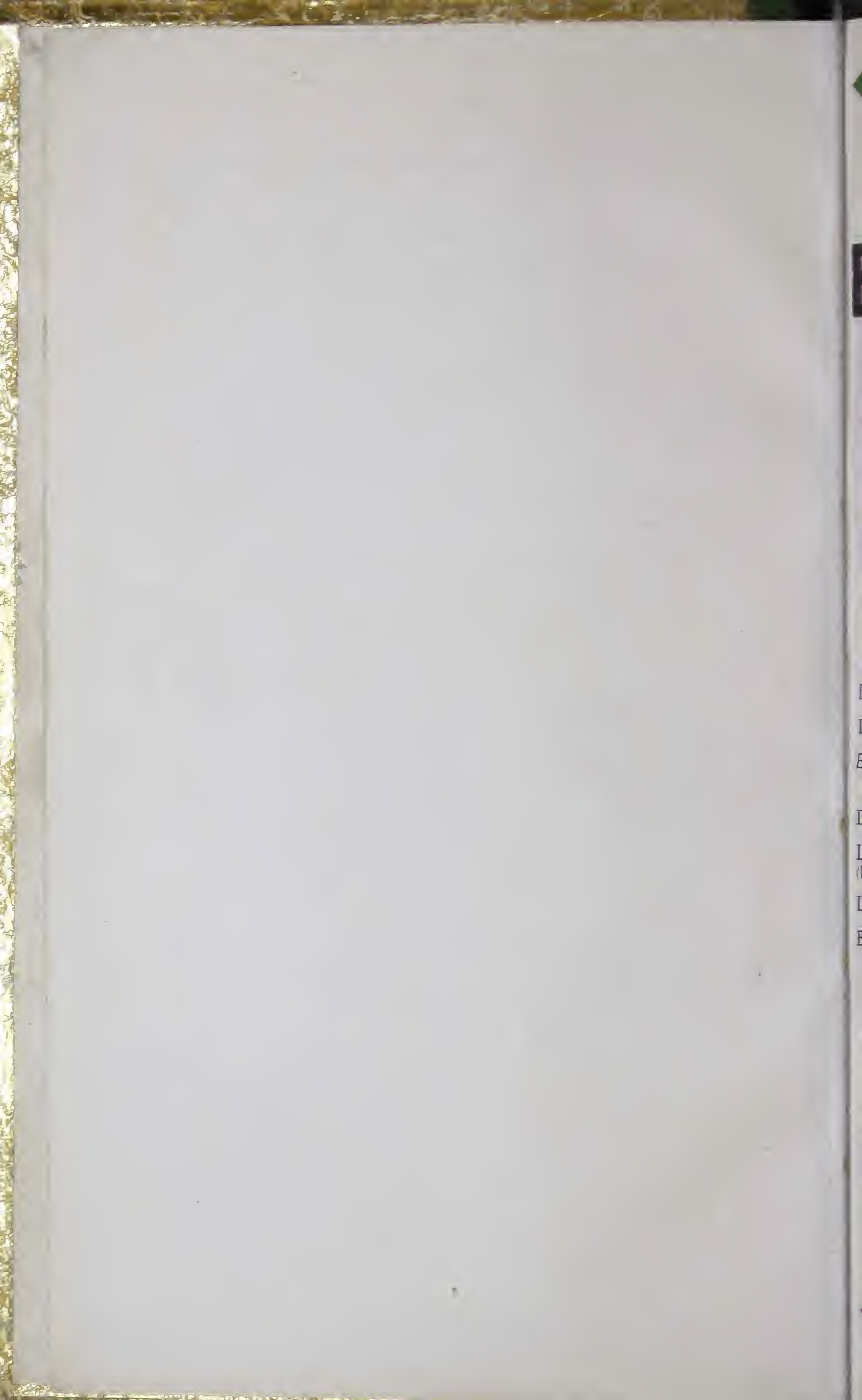

BAXENDALE & CO. LTD.

Catalogue No. 561

BAXENDALE & CO. LTD.

Manufacturers, Merchants, and Shippers
to the Plumbing, Building,
Decorating, Electrical, Glass,
Hardware and Ironmongery Trades

Regd. Office and Showrooms :

MILLER STREET, MANCHESTER, 4.

Telephone : **BLAckfriars 8282** (26 lines)

Lead Works : **TRAFFORD PARK**

Branches at :

LIVERPOOL 3. 4-18 **Pembroke Place.** *Tel. : Royal 6321*

EDINBURGH 1. **Grassmarket and King's Stables Road.**
Tel. : Fountainbridge 6303

DUBLIN. **Capel Street.** *Tel. : Dublin 76711*

LANCASTER. 38 **Cable Street.** *Tel. : Lancaster 3182*
(F. B. Norris & Co. Ltd.)

LEEDS. **Queen Street.** *Tel. : Leeds 20291*

BLACKPOOL. **Caunce Street.** *Tel. : Blackpool 20813*

LONDON OFFICE :

223 **GRAND BUILDINGS,**
TRAFALGAR SQUARE, W.C.2

Telephone : WHITEHALL 5782

Reg. Trade Marks :

“Beanco,” “Homestead,” “Paramount,” “Texo,” “Blackintosh,”
“Bedale,” “Cellapuro,” “Baxinol.”

LIVERPOOL · EDINBURGH · DUBLIN

IMPORTANT

DELIVERIES. Regular Deliveries are made by our own motors over a very large area.

SPECIAL GOODS, URGENTLY WANTED. If customers will state the maximum time they can allow for the execution of an order, we will endeavour to supply within the time stated, but we cannot accept cancellation of goods ordered and partly made which through unavoidable delay (from any cause), cannot be sent up to time. Goods made to order cannot be taken back under any circumstances. Our employees have instructions to refuse all goods returned, unless arrangements have been previously made with us to accept them.

PACKAGES. Packages are charged at lowest possible rates, but full prices will be allowed if returned (with straw when used) carriage paid, and in good condition, within a reasonable time. Customers should see that their Name and Address is attached to all empties, and advise us by post how and when despatched.

BREAKAGES. Goods sent by our own Motors should be examined on delivery, and anything damaged or broken should be returned by the same conveyance, otherwise we cannot accept responsibility. Goods sent by rail, are sent at Railway Company's risk, and if broken or damaged in any way, instructions must be sent immediately to the Railway Company to call and inspect, at the same time we must be notified in writing.

WHEN ORDERING. When ordering Goods from this Catalogue, please state Number and Description of article. Do not cut out the illustrations. Please do not order "as before" or "as last" without giving date and folio from previous invoice, as otherwise delay and misunderstanding will probably arise.

URGENT ORDERS. Urgent orders should always be addressed to the Firm and not to individuals, as this frequently causes delay. Goods ordered from Quotation should always give our reference.

CORRESPONDENCE. All Orders, Enquiries, etc., should give Customer's Name, Address and Trade in full, and also reference to our particular department concerned. If Telegrammatic Reply is wanted, please enclose remittance.

ILLUSTRATIONS, DESCRIPTIONS AND DIMENSIONS. The illustrations and descriptions given are as near as possible to the original articles, but we do not guarantee to reproduce them exactly in all cases, as improvements are continually being made which may affect the general appearance. Dimensions are approximate.

ACCOUNTS. Unless a ledger account has been arranged, a remittance to cover cost of goods and also packages should accompany each order.

PRICES are subject to alteration without notice and to our acceptance upon receipt of order.

THIS CATALOGUE cancels all previous issues.

BAXENDALE & CO. LTD.

INDEX

(For Numerical Index see pages 400-408).

	PAGE		PAGE
A			
Advertising Lamps and Signs ...	333	Bedale Roofing Felt ...	237
Adjustable Pipe Die ...	385	Beeston Boilers & Radiators 278 to	299
Anti-Splash Waste Pipe Terminal	254	Beer Engines and Fittings ...	215
Anti-Splash Tap Filter Automatic	154	Betex Damp Wall Preparation ...	347
Air Grid ...	242	Benders (Pipe) ...	386
Air Valves ...	178	Bends (Lead) ...	159
Aluminium Strip Roofing ...	226	Bevelled Glass ...	324, 325
Automatic Ejector ...	183	Bib Taps ...	126, 127
Automatic Injector ...	183	Bib Tap and Wall Plate ...	140
Automatic Flushing Tanks and		Bidets ...	118
Cisterns ...	116, 117	Blackintosh Roofing ...	236
Arduro Water Paint ...	341	Blow Lamps ...	360, 361
Asbestos Steam Packing ...	187	Blow Pipes ...	375
Asbestos Rings (Proofed) ...	189	Boilers Britannia ...	280 to 283
Asbestos Tape ...	189	Boilers Hot Water ...	306 to 308
Asbestos Yarn ...	186	Boilers Hot Water & Radiators 278 to	299
Assisting Valve ...	218	Boilers Copper ...	166
B			
Back Plates ...	155	Boilers Greenhouse, etc. ...	288 to 291
Back Boilers ...	166 to 171	Boiler Unions & Ferrules ...	151
Back Nuts ...	155	Boilers Wrought Welded 167 to	171
Back Pressure Valves ...	138	“Boss” White ...	351
Baker's Soldering Fluid ...	157	Bosses (Tap) ...	151
Balls and Floats ...	154	Brackets, Lavatory ...	42 to 44
Ball Valve ...	152, 153	Brackets, Towel Rail ...	51
Bar Fittings ...	215, 217, 219	Brackets Cantilever ...	51 & 86
Bar Sinks ...	220	Brackets Cistern ...	124
Basin Wrench ...	368	Brackets Gutter ...	266
Bath Fittings (Sets) ...	144, 145	Brass Ferrules, etc. ...	150
Bathroom Accessories 58, 59 & 62, 63		Brass Gauge Cocks ...	181
Bathroom Furniture ...	64 to 66	Brass Urn Taps ...	218
Baths ...	16 to 25	Brushes Paint, etc. ...	354 to 356
Bathroom Suites ...	10 to 15	Bucket (Fire) ...	196
Bath Wastes ...	147	Buffers (Closet) ...	108
Bath Overflows ...	147	Button Spreader ...	117
Bath Fittings (Supply) ...	26 to 29	C	
Bath Fittings ...	147	Cabinets Bathroom ...	64, 65
Basses ...	375	Cantilever Brackets ...	51 & 86
Beancolite Wood Preservative ...	344	Cathedral Glass ...	316
		Caulking Compound ...	157
		Cast Iron Back Boilers 167 to	171
		Casement Metal ...	234, 235
		Cellapuro Cleaner ...	61

INDEX

	PAGE		PAGE
Centrifugal Pump	274	Drain Plungers and Stoppers ...	365
Chamois Leathers	343	Drain Cleaning Rods and Fittings	363
Check Valves, Steam	175	Drain Cocks	177
Chemical Sanitation	109	Drain Pipes and Fittings ...	245
Chains & Stays	155	Drills	393
Chisels	372	Drilling Machines	392
Chimney Pots	244	Drinking Fountain	53
Chimney Sweeping Apparatus ...	363	Dry Colours	340
Chimney Tops and Cowls ...	243	Dryers Paste	340
Cistern Fittings	124		
Cisterns, Open Top	172, 173	E	
Cistern (Pulls) and Guide ...	125	Easiclene Sink Units	76, 77
Cisterns, Cleaners Sink	94	Elbow Back Plates	155
Closet Hoppers	104	Electric Drills, Saws and Grinders	388 to 391
Closet Seats	106, 107	Elsan Closets	109
Coal Plates	252	Embossed and Brilliant Cut Glass	331
Cocks Plug	130	Essex Cylinder Connections ...	150
Colours, in Oil, Turps and Water	340	Expansion Pipes and Fittings	304, 305
Coleman's Cylinder Connections...	150	Extension Ladders	398
Connection Sockets (Lead) ...	105	Export Section	100 to 103
Cones (W.C.)	156		
Cookers and Water Heaters	306 to 308	F	
Copper Automatic Syphon ...	117	Fascia Signs	330
Copper Back Boilers	166	Felts, Roofing	236, 237
Copper Balls and Floats	154	Felt Sheets (Canvas Backed) ...	270
Copper Sheet (Roofing)	226	Ferrules	150, 151
Copper Cylinders	160 to 163	Fibre Jointings	188
Copper Pipe Flap	154	Figured Roll Glass	317 to 321
Copper Flue Boilers	166	Fire Hydrants Ground Boxes, etc.	191
Copper Tubes—Useful Information	224	Fire Hydrants	191 & 192
Copper Tubes (Underground) ...	225	Fire Hose	192 & 196
Corrugated Metallic Packing Rings	188	Fire Bucket Bracket	196
Corrugated Sheets... ..	230	Fire Extinguishers	194, 195
Cowls, Chimney Tops, etc. ...	243	First-Aid Fire Appliances	192 to 196
Cuprinol	345	First-Aid Fire Hose Reel ...	196
Cylinders, Hot Water	160 to 163	Force Pumps (Brass)	272
		Flue Pipe and Fittings (Gal.) ...	211
D		Flushing Cisterns	119 to 122
Damp Course	270	Flush Pipes	123
Damp Wall Preparation	347	Flush Pipe Clips	123
Dead Lights	231	Flush Pipe Connection	156
Decorators' Paste	352	Fluxite Soldering Paste	157
Decorators' Supplies	353	Frost Taps (Combination) ...	138
Dimplex Radiators	293		
Distemper Beanco	341		
Drainers, Sink	87		

INDEX

	PAGE
Fungicides and Insecticides ...	345
Furnace Pans Rustless ...	362
Furnaces (Blast) ...	381
Fusible Plugs ...	175
Fullways Equilibrium Float Valve	153

G

Galvd. Bolts and Nuts ...	230
Galvd. Corrugated Roof Lights ...	231
Galvd. Corrugated Sheets for Roofing, etc. ...	230
Galvd. Nails, Screws and Washers	230
Galvd. Ridging ...	230
Galvd. Tanks, Cisterns and Cylinders ...	172, 173
Galvafruid ...	350
Gas Fittings (Small) ...	205 to 210
Gauge Cocks ...	181
Gauge Glasses ...	179
Gauge Glass Protectors ...	182
Gauges Steam ...	181
Gauges Water ...	181
Gauge Washers (India-rubber) ...	182
Gun Metal Steam Valves and Cocks	174
Gun Metal Pipe Fittings ...	200 to 203
Gutters and Connections ...	261 to 263
Glass ...	310 to 329
Glass Bricks ...	328
Glass Cutters ...	358
Glass Paper and Emery Cloth ...	343
Glass Diagrams of Curves for Bending ...	326, 327
Glass Ventilators and Payholes ...	323
Glaziers' Diamonds ...	358
Glazed Lavatory Divisions	96, 97
Grids and Frames (Street)	251, 252

H

Hairdresser's Lavatories ...	38
Hair Felt ...	270
Hammers ...	370 & 376
Heating Stoves ...	292 & 309
H.R. Gutters and Connections ...	261
Hinges (Closet Seat) ...	108
Hospital Lavatory Fittings ...	129
Hot Water Boilers ...	306 to 308
Hot Water Pipes and Fittings	300 to 305
Hydraulic Drawn Lead Traps ...	158
Hydraulic Test Pumps ...	272

PAGE

I

Ideal Boilers ...	280 to 283, 286, 287 & 289
Ideal Radiators ...	294, 295 & 299
Immersion Heaters ...	165
Iron Cement ...	387
Insulating Jacket (Copper Cylinder)	163
Injector (Self-Acting Restarting)	183

J

Jointing Compound ...	157
-----------------------	-----

K

Kitchen and Bathroom Accessories ...	62
--------------------------------------	----

L

Laboratory Sinks ...	85
Laboratory Taps (Water) ...	132, 133
Laboratory Fittings (Gas) ...	207
Laboratory Fittings (Gun-metal) ...	132, 133
Ladders ...	398
Ladder Brackets ...	387
Ladles ...	374
Lavatories ...	32 to 38 & 40 to 48
Lavatory Fittings ...	143 & 146
Lavatory Supply Taps ...	146
Lavatory Supply Pipes ...	50
Lavatory Ranges ...	46 to 48
Lavatory Taps ...	146
Lavatory Wastes ...	148
Lead Bends and Offsets ...	159
Lead Sheets and Pipe ...	222
Leaded Lights ...	334 to 337
Lead Wool ...	221
Lengthening Sockets ...	151
Levels ...	366
Light Alloy Die Heads ...	385
Liquitexo Roofing Material ...	239
Liquid Soap ...	61
Lomoto Steam Packing ...	186
Loy (Metal) ...	359

INDEX

	PAGE		PAGE
M			
Malleable Iron Fittings	197	Pillar Taps (High Neck, Sink) ...	141
Manhole Covers and Frames 246 to	250	Pipe Benders	377
Manhole Steps	250	Pipe Clips	204
Master Benders	386	Pipe Caulking Clamp or Clip ...	381
Metal Casements	234, 235	Pipe Checker	177
Metal Pots	374	Pipe Fittings (Gun Metal) 200 to	203
Metallic Tubing and Fittings		Pipe Hooks	204
(Flexible)	190	Pipe Jointers	381
Mirrors (Bathroom)	67	Pipeline Strainers	184
Mirrors (Splashbacks)	68, 69	Piston Pump Stuart	273
Monkey Pans	101	Plate Glass	328, 329
N			
Nameplates and Letters, etc. ...	332	Pliers	373 & 380
Nails, Tacks, Rivets, etc. ...	229	Polycell Adhesive	352
Newcastle Boilers	169	Polythene Tubing	227
O			
O.G. Gutters and Connections ...	262	Plumbers' Force Pumps	272
Oil Drums and Cabinets ... 343 &	346	Plug Cocks	130
Oil Furnace (Portable)	381	Plugs (Basin)	149
Oil-O-Matic	277	Plumbers' Stove	381
Oriental Closets	100 to 103	Plumbers' Tools	363 to 381
P			
Packings (Steam)	186, 187	Plumbers' Wood Ware	377, 379
Painters' and Glaziers' Tools ...	357	Pumps	271 to 275
Paints and Varnishes ... 338 to	342	Pressure Gauges	181
Paint Brushes and Varnish		Pressure Reducing Valves ...	138
Brushes	354 to 356	Puncheon Wire Mesh	399
Paper Hangers' Requisites ...	353	R	
Paramount R.W. Goods ... 256 to	269	Racking Cocks	216
Paramount Soil Pipes, etc. 256,	257	Radiators	293 to 299
Paste Powders	352	Radiator Air Valves	178
Pavement Lights	255	Radiator Brushes	356
Payholes	323	Rainwater Heads	264, 265
Pedestal Lavatories ... 32 to	37	Rainwater Pipes and Fittings 256 to	269
Pedestal W.C. Pans ... 98, 99		Rawlplugs and Rawlbolts ...	228
Penberthy Water Heater ... 177		Rayburn Cooker	306
Perforated Zinc	221	Reducing Valve	180
Philplug Cold Caulking Compound	157	Recessed Fittings (Bathroom) 56,	57
		Reeded Glasses	314, 315
		Riddles	399
		Rentokil	346
		Robin Hood Boilers	285
		Rolled, Rough Cast and Wired	
		Glass	322
		Roller Towel Rail	59
		Roof Lights, Cast Iron and Galv.	231
		Roofing Felts, Beanco, Bedale,	
		Blackintosh	236, 237
		Ropes, Blocks and Thimbles ...	387
		Rubber Steam Sheeting	188
		Rubber Washers, Steam Quality ...	189
		Rules	366

INDEX

	PAGE		PAGE
S			
Safety and Vacuum Valves ...	179	Stand, Lavatory, Beanco Pattern	51
Safety Valves ...	180	Stands, Lavatory ...	40, 41 & 51
Sanitary Connections (Cast Iron) ...	267	Stand Pipes ...	192
Saws ...	371	Steamheated Water Boiler, Self	
Screwing Tools ...	382 to 385	Feed Type ...	164
Sealing Compound ...	348, 349	Steam Kettles ...	164
Secomastic ...	350	Steam Trap (Welldeck) ...	184
Sectional Boilers ...	278 to 283	Steel Wire Riddles ...	399
Sectional Pipe Coverings ...	177	Steel Shelving ...	387
Seelastik ...	348, 349	Stocks and Dies ...	383 to 385
Sheet Lead and Lead Pipes ...	222	Sheet Glass ...	310
Shampoo Fitments ...	39	Sheet Rubber ...	188
Showers ...	28 to 31	Signs ...	330
Sinks ...	82 to 86	Stoneware Drain Pipes and Fittings	245
Sink Fittings ...	142	Stop Tap Boxes ...	253
Sink Units ...	70 to 77	Stop Tap Keys ...	155
Sink Unit Tops ...	78, 79	Stop Taps and Ferrules ...	134 to 137
Sink Wastes and Tub ...	149	Street Grids and Frames ...	251, 252
Sink and Washtub Sets ...	80, 81	Street Fire Grates and Baskets ...	362
Sink Mixer Taps ...	128, 129	Sump Pump, Electric ...	273
Siphon (Wrought-iron) ...	181	Supataps ...	139
Slate Rippers ...	376	Supply Taps (For Automatic Tank)	116
Slaters' Knife or Axe ...	376	Surgeons' Fittings (Water) ...	129
Slop Hoppers ...	93, 94	Swing Shower Screen ...	30
Slop Hoppers and Sink Units ...	94	Swivel Taps ...	129
Sludge Cocks ...	138	Squatting Closets ...	102
Sluice Valves ...	190		
Soaps ...	343	T	
Soap and Sponge Trays and		Tamac Fire Cement ...	347
Baskets ...	60	Tanks, Cisterns, Cylinders	172, 173
Soap Dispensers ...	61	Tank Gauge ...	181
Solon Electric Soldering Iron ...	374	Tanks, Hot Water, Combination	163
Shower Curtains and Screens	30, 31	Tapping Cocks ...	216, 217
Solder and Bearing Metal ...	227	Taps, Bath and Lavatory, etc.	126 to 146
Soldering Iron ...	374	Taps, Bib ...	126, 127
Soil Pipes and Connections	268, 269	Taps, Globe ...	145
Soil Pipe Ferrules ...	106	Tap, Lever ...	155
Soil Pipe Fittings, etc. ...	105	Tap Lug (Brass) ...	154
Soil Pipe Sockets ...	106	Taps, Sink ...	141
Spanners ...	368	Taps, Sink Mixer ...	128
Splashbacks ...	67 to 69	Taps, Self-Closing ...	131
Spirit Taps ...	216 to 218	Tap Top Parts and Valves ...	156
Sponges ...	343	Tap Reseating Tools ...	380
Spontex ...	356	Tap Hole Stoppers ...	147
Spirax Steam Trap ...	184	Tap Washers ...	156
Spray Fittings ...	27 to 29		

INDEX

	PAGE		PAGE
Tee Squares	358	Ventilators	232, 240 to 243
Terminals (Waste Pipe)	254	Ventilators, Glass	323
Texo Roofing Compound	238	Ventilating Window Frames	233
Thermo Pak	276	Vices	394, 395
Thermometers	178 & 291	Vitrolite Glass	311 to 313
Throttle Valve	175		
Tile Cement (Tiluma)	351	W	
Timber Fluid	346	Wall Stays (Towel Airer)	55
Tinmen's Snips	373	Washing Boilers (Gas)	211
Toilet Suites	88 to 93	Washing Fountain	49
Tools	366 to 386	Waste Water Pipe Cleaners	364
Torcade Flushing Cisterns	119 to 121	Water Boilers, Fourness	214
Towel Airers	54, 55	Water Boiler (Steam)	164
Towel Airer Flanges	55	Water Gauge Glass Protectors	182
Towel Airer Valves and Unions	55	Water Heaters (Gas)	212 to 214
Towel and Grab Rails	59	Water Heater	165 & 177
Trap, Copper	148	Water Meter and Manhole	
Trap, Lavatory	148	Covers	246 to 250
Trap, Lead	158	Water Paint, Arduro	341
Trap, Steam	184, 185	Water Softener	52
Trap Screws	151	W.C. Cones	156
Treacle and Urn Taps	218	W.C. Pans	95
Triplex Safety Glass	313	W.C. Seats	106, 107
Trowels	376	W.C. Seat Fittings	108
Tube Cutter	397	Wellstood Cooker and Water	
Tube Wrenches	396	Heater	307
Twist Drills	303	Wellstood Water Heater	307
		Wheel Valves	175
U		White Lead Paint, 'Beanco'	338
Urinals	110 to 114	Wiping Cloths	375
Urinals, Wall	115	Wire Guards	241 & 399
Urinal Grating	117	Wire Mesh Sieves	399
Urinal and Lavatory Divisions	95 to 97	Wrenches	396
Underground Copper Tubes	225	Wringer Plate, Galvanized	86
		Wrought Iron Gutter Brackets	266
		Wrought Welded Boilers	167 to 171
		Wrought Iron Tubes and	
		Fittings	198, 199
V		Z	
Valves, Check	173	Zenth High Pressure Valve Twist	
Valves (Safety)	180	Packing	186
Valves and Unions (Radiator)	56 & 176	Zinc and Wire Gauge	223
Varnishes	342		
Varnish and Paint Brushes	354 to 356		

BAXENDALE & CO. LTD.



Miller Street Warehouse and Views in our Showrooms.

LIVERPOOL · EDINBURGH · DUBLIN



PLATE No. B 6317

OUR illustration shows a bathroom suite of superlative quality and ultra-modern style, comprising the No. B6325 Neo Classic bath with a concealed fitting to supply plunge and shower and including a plate-glass hinged screen with chromium-plated frame. The No. B6326 Neoline vitreous china pedestal lavatory basin with chromium-plated hot and cold supply fitting of special design, the No. B6327 Neolux Toilet Suite with plastic seat and cover and the No. B6328 Neo Spray Bidet with chromium-plated supply fittings for rim and spray complete this delightful Bathroom.

This bathroom suite is available in white, corallin pink, ming green, ivoire-de-medici, claire-de-lune blue, and pearl grey.

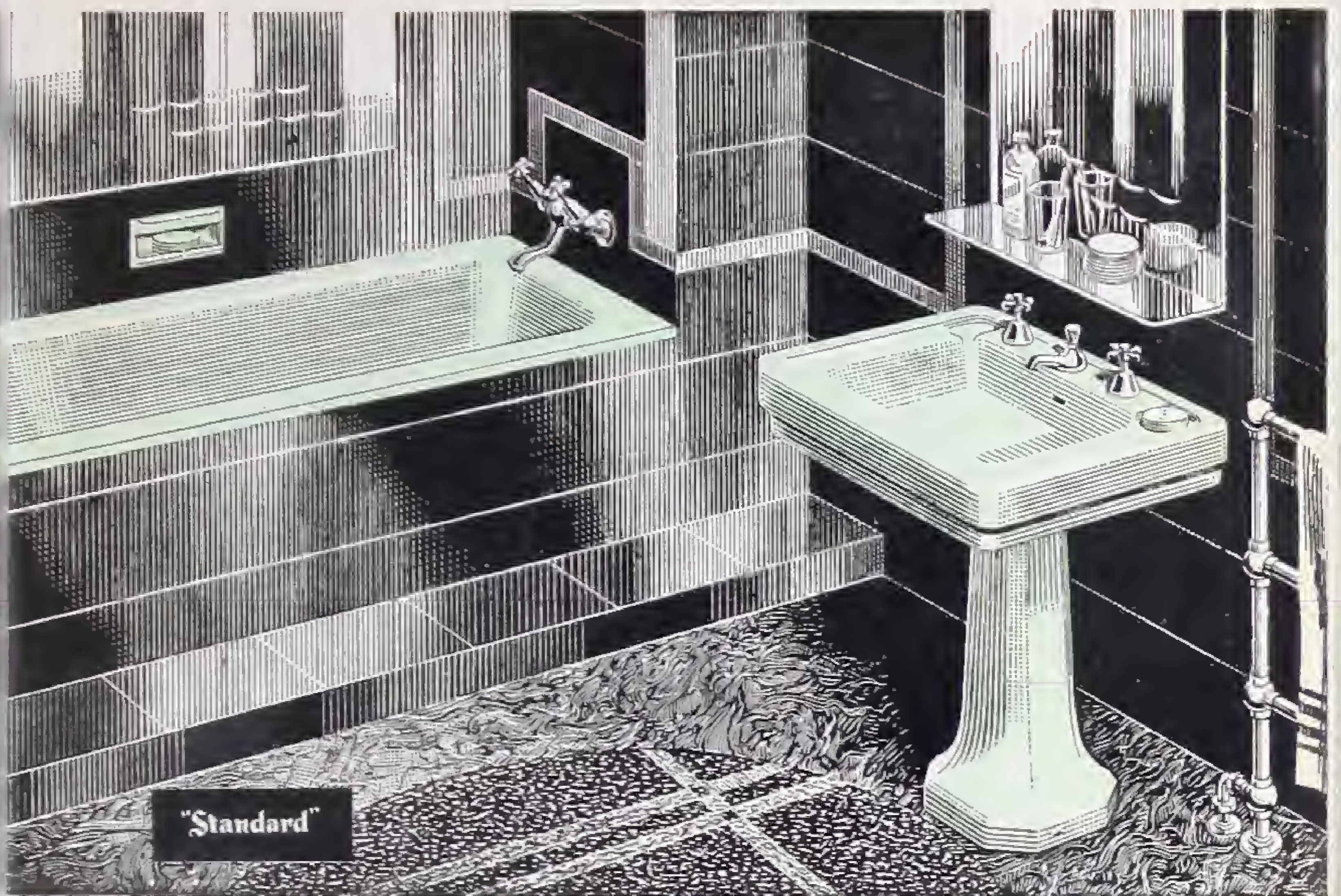

PLATE No. B 6318

THE application of Vitrolite Glass for bathroom walls is clearly shown in the above illustration. The sanitary fittings illustrated comprise the No. B6329 "Adapto" bath in porcelain-enamelled cast-iron with chromium-plated hot and cold wall supply fitting, and above the bath is fitted an oblong soap holder in vitreous china. The lavatory basin is the No. B6330 "Surrey" type in vitreous china with pedestal and chromium-plated mixer fitting with single supply nozzle. The towel rail just in view is the No. B5019 pattern with $1\frac{1}{4}$ in. chromium-plated round tubes, suitable angle-control valve and union. Mirrors, plate glass shelves made to customer's own designs, and also vitrolite glass in various colours for bathroom walls can be supplied by our Glass Department. The Sanitary Ware illustrated above is available in white, corallin pink, ming green, ivoire-de-medici, claire-de-lune blue, and pearl grey.

COLOURED SANITARY WARE

No. B 6325 NEO-CLASSIC BATH

A porcelain-enamelled cast-iron one-piece apron bath for fitting in right or left hand corner, with tiling strip round the built-in edges and levelling strips beneath, complete with chromium-plated round design built-in fittings comprising $\frac{3}{4}$ in. valves with metal capstans, nozzle supply fitting, $1\frac{1}{2}$ in. lift-up waste and integral $1\frac{1}{4}$ in. overflow, waste outlet with $1\frac{1}{2}$ in. P-trap.

Inside Sizes			Overall Sizes		
Length	Width	Depth	Length	Width	Height
5 ft. $6\frac{1}{2}$ in.	$24\frac{1}{4}$ in.	17 in.	6 ft. $2\frac{1}{4}$ in.	$30\frac{1}{2}$ in.	18 in.

NOTE.—These dimensions are approximate and may vary to the extent of $\frac{1}{2}$ in.

No. B 6326 NEOLINE PEDESTAL LAVATORY BASIN

A flat-topped basin of generous proportions and modern design in best quality vitreous china; $\frac{1}{2}$ in. chromium-plated Mastercraft design hexagonal hot and cold valves with centre supply nozzle and lift-up waste fitting; outlet fitted with $1\frac{1}{4}$ union; size 27 in. \times 22 in.

No. B 6327 NEOLUX TOILET SUITE

Comprising 2, $2\frac{1}{2}$, or 3-gallon vitreous china cistern and cover, with special vitreous china valveless siphon fittings and chromium-plated lever action; vitreous china siphonic basin with P-trap, plastic seat and cover to match ware; pottery in white or colours. Height from floor level to top of cistern $31\frac{3}{4}$ in., projection $28\frac{5}{8}$ in. *The vitreous china siphonic basin can be supplied with a turned-down outgo to form an S-trap, if necessary.*

The above sanitary equipment is available in white and the following colours: Corallin pink, ming green, ivoire-de-medici, claire-de-lune blue, and pearl grey.

It will be noted that the bath is illustrated with round design fittings and the lavatory basin with hexagonal fittings. Either types are available for complete bathroom suites. When ordering, please specify which pattern is required.



"Standard"



*This Bathroom Suite
is illustrated in
ivoire-de-medici.*

No. B 6325
NEO-CLASSIC BATH

No. B 6326
NEOLINE PEDESTAL
LAVATORY BASIN

No. B 6327
NEOLUX TOILET SUITE



COLOURED SANITARY WARE

No. B 6253 THE BRAMHALL BATH

A modern cast-iron bath with long soap shelf and two chromium-plated hand grips and low front. Fitted with one front and one end cast-iron panels with chromium-plated corner and end pieces, all porcelain-enamelled in white or colours; $\frac{3}{4}$ in. chromium-plated hot and cold pillar taps, $1\frac{1}{4}$ in. overflow and chain, $1\frac{1}{2}$ in. waste with trap and vulcanite plug.

Inside Sizes			Overall Sizes		
Length	Width	Depth	Length	Width	Height
5 ft. 6 in.	$22\frac{3}{4}$ in.	$17\frac{1}{2}$ in.	6 ft. 1 in.	$30\frac{3}{4}$ in.	20 in.
	<i>or</i>			<i>or</i>	
5 ft. 0 in.	$22\frac{3}{4}$ in.	$17\frac{1}{2}$ in.	5 ft. 6 in.	30 in.	20 in.

No. B 6323 PEDESTAL LAVATORY BASIN

Flat-topped design with slightly round front, in best quality white or coloured vitreous china, $\frac{1}{2}$ in. chromium-plated hot and cold pillar taps, pop-up waste fitting with $1\frac{1}{4}$ in. union; sizes: 24 in. \times 20 in., 27 in. \times 22 in.

No. B 6324 TOILET SUITE

Comprising 2, $2\frac{1}{2}$, or 3-gallon vitreous china cistern and cover, with special siphon fittings and side lever action, vitreous china siphonic basin with P or S trap; black plastic seat and cover; pottery in white or colours.

Height from floor level to top of cistern $30\frac{1}{2}$ in.

Projection 2 gallon size 27 in., $2\frac{1}{2}$ gallon size $27\frac{1}{2}$ in., 3 gallon size $28\frac{1}{4}$ in.

The above sanitary equipment is available in white and the following colours: Green, primrose, blue, ivory, turquoise, amber, and peach.



*This Bathroom Suite
is illustrated in
turquoise.*



No. B 6253
THE BRAMHALL BATH

No. B 6323
PEDESTAL LAVATORY
BASIN

No. B 6324
TOILET SUITE

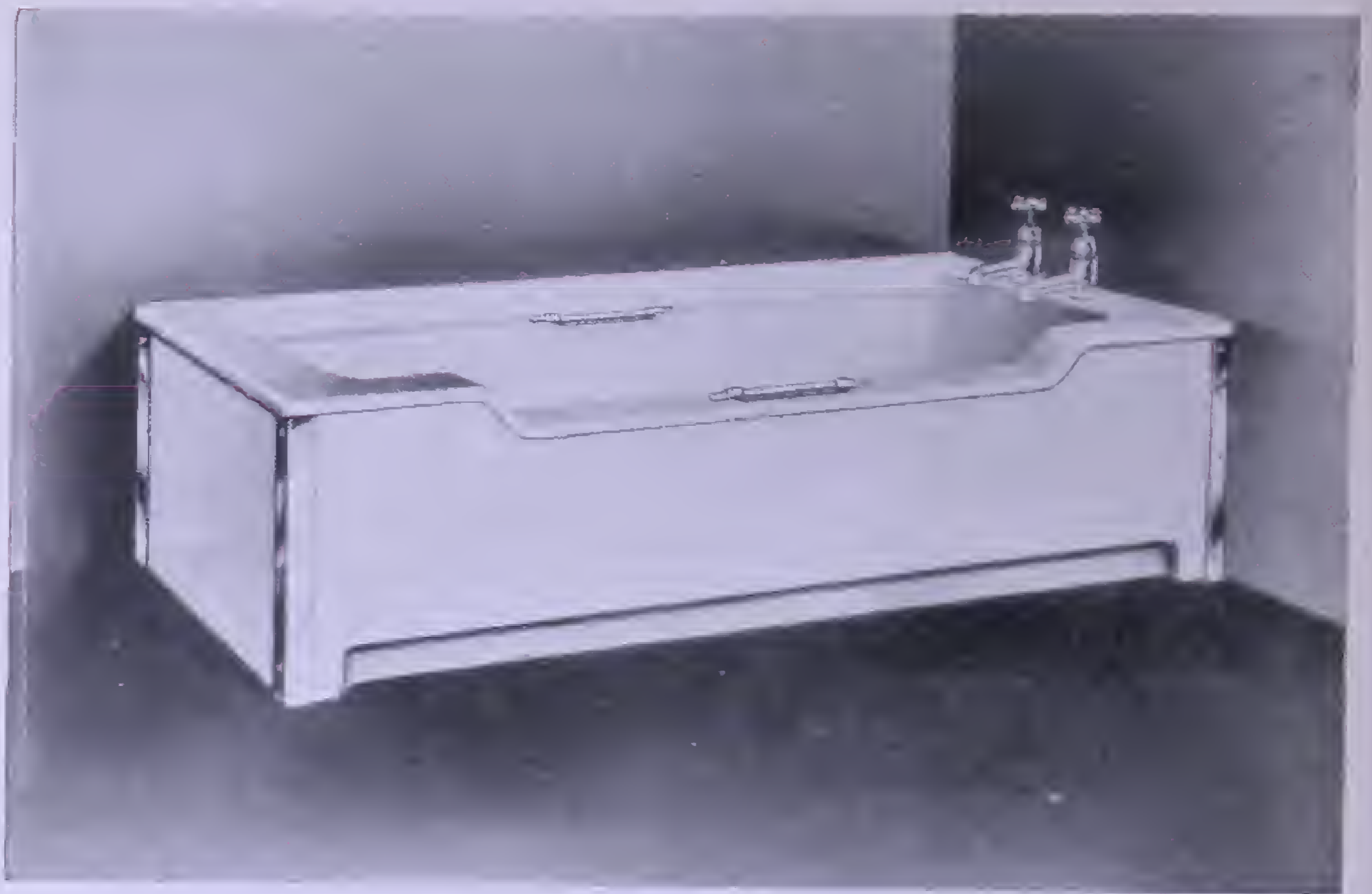

No. B 6250 THE HADRIAN BATH

A cast-iron bath of imposing appearance and large dimensions, complete with two chromium-plated hand grips, long shelf at back, and low front ; fitted with C.I. panels, all porcelain-enamelled in white or colours ; $\frac{3}{4}$ in. chromium-plated hot and cold pillar taps, $1\frac{1}{4}$ in. overflow and chain, $1\frac{1}{2}$ in. waste with trap and vulcanite plug.

Inside Sizes

Overall Sizes

Inside Sizes			Overall Sizes		
Length	Width	Depth	Length	Width	Height
5 ft. 6 in.	23 in.	19 in.	6 ft. 3 in.	33 in.	21 in.

This bath can be supplied in the following colours : Jade green, blue, ivory, primrose, amber, turquoise, and pink.

Please refer to diagrams on page 26 when ordering Panel Baths.

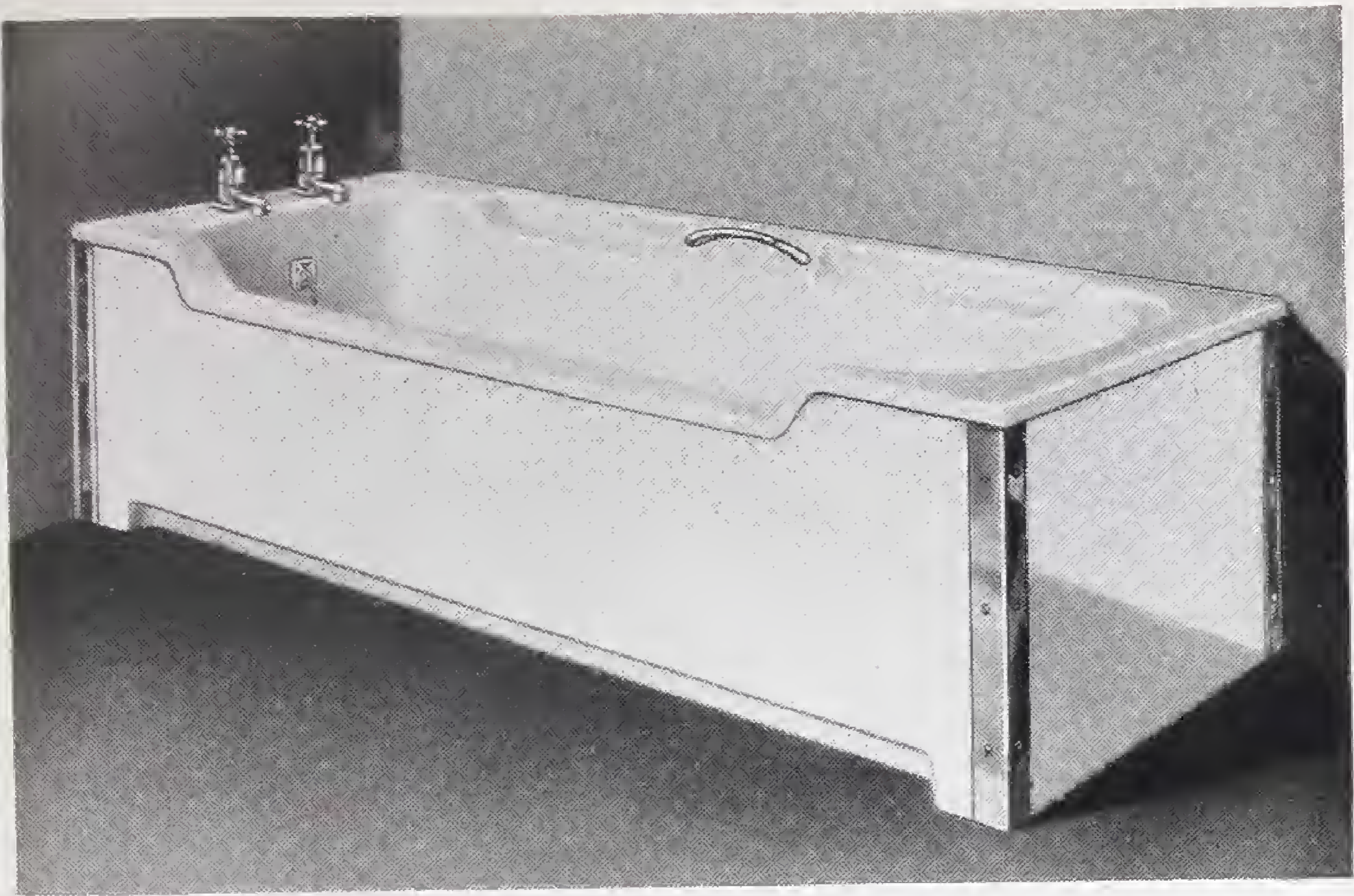

No. B 6251 THE JULIAN-DE-LUXE BATH

An attractive cast-iron bath with two soap recesses, one chromium-plated hand grip, and low front, fitted with C.I. panels, incorporating toe recess ; all porcelain-enamelled in white or colours ; $\frac{3}{4}$ in. C.P. hot and cold round pillar taps, $1\frac{1}{4}$ in. overflow and chain, $1\frac{1}{2}$ in. waste with trap and vulcanite plug.

Inside Sizes

Overall Sizes

Length	Width	Depth	Length	Width	Height
5 ft. 6 in.	23 in.	19 in.	6 ft. 3 in.	$30\frac{1}{2}$ in.	21 in.

No. B 6252 THE JULIAN MINOR BATH

A cast-iron bath with all the attractive features of the Julian-de-Luxe and similar in appearance but more suitable for the modern smaller bathroom, with $\frac{3}{4}$ in. chromium-plated hot and cold round pillar taps, $1\frac{1}{4}$ in. overflow and chain, $1\frac{1}{2}$ in. waste with trap and vulcanite plug.

Inside Sizes

Overall Sizes

Length	Width	Depth	Length	Width	Height
5 ft. 0 in.	22 in.	18 in.	5 ft. 8 in.	28 in.	$19\frac{1}{2}$ in.,

The above baths can be supplied in the following colours : Jade green blue, ivory, primrose, amber, turquoise, and pink.

N.B. Square pattern pillar fittings can be supplied at an extra charge.

To preserve your bath's original lustre clean with Cellapuro.



No. B 6331 THE KENT BATH

A luxury bath combining generous dimensions and a very neat appearance, complete with one chromium-plated hand grip, two soap compartments; fitted with porcelain-enamelled cast-iron panels having chromium-plated corner and end pieces; $\frac{3}{4}$ in. chromium-plated smooth body hot and cold pillar mixer fitting with supply nozzle, hand spray, and chromium-plated support; $1\frac{1}{4}$ in. overflow and chain, $1\frac{1}{2}$ in. waste with trap and vulcanite plug.

Inside Sizes			Overall Sizes		
Length	Width	Depth	Length	Width	Height
4 ft. 11 in.	23½ in.	17½ in.	5 ft. 6 in.	31 in.	18½ in.

No. B 6332 THE KENT-DE-LUXE BATH

A luxury bath exactly similar to the above but of larger size.

Inside Sizes			Overall Sizes		
Length	Width	Depth	Length	Width	Height
5 ft. 5 in.	23½ in.	17½ in.	6 ft. 0 in.	31 in.	18½ in.

The above baths can be supplied porcelain-enamelled white and in the following colours: Jade green, blue, ivory, primrose, amber, turquoise, and pink.

NOTE.—Both the above baths can be supplied with ordinary chromium-plated smooth body hot and cold pillar taps. Please state which fittings are required, when ordering.

Please refer to diagrams on page 26 when ordering Panel Baths.

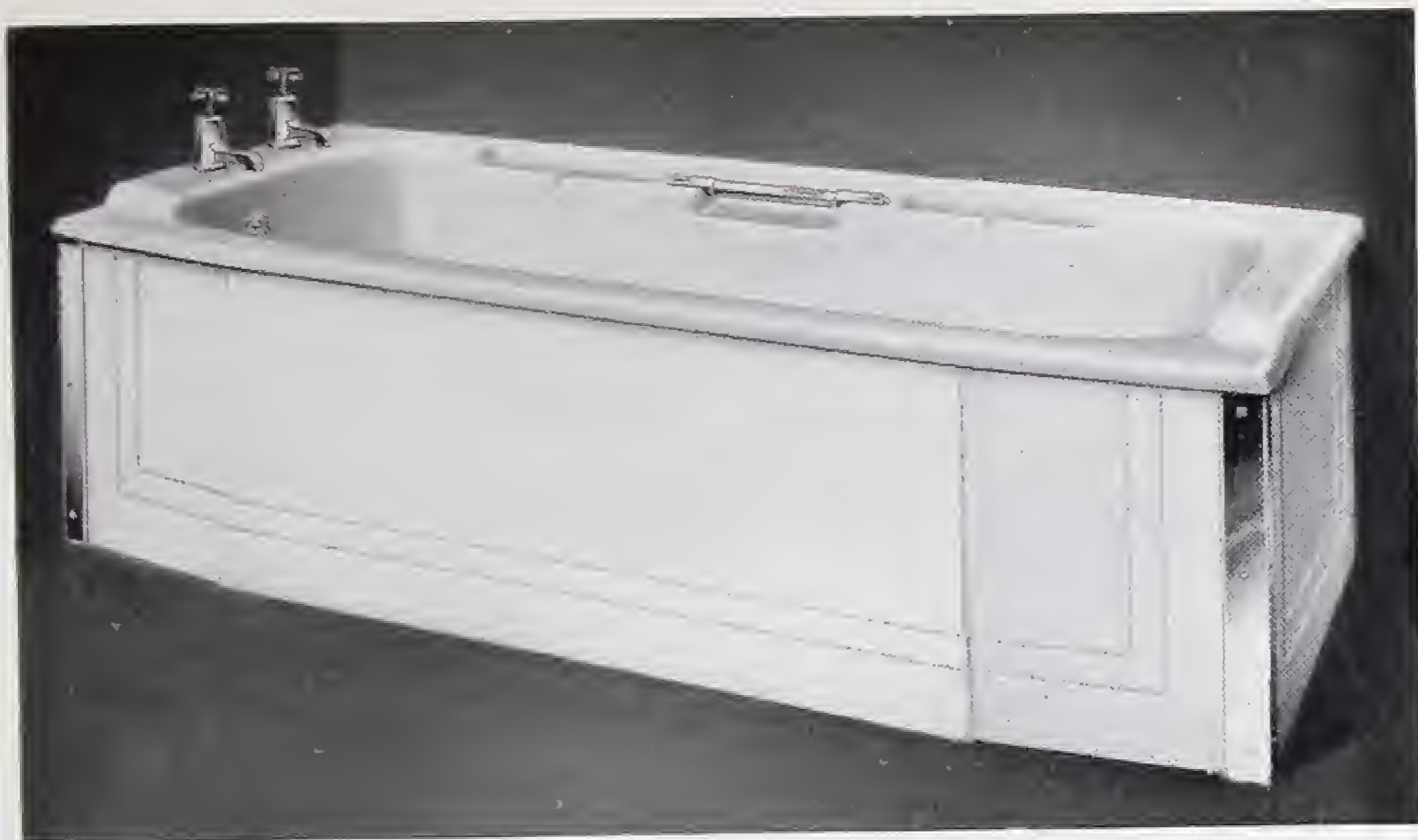

No. B 6333 THE GLEN DEVON BATH

A cast-iron bath on novel and attractive lines, complete with two soap recesses on the back rim and a chromium-plated hand grip ; fitted with cast-iron panels, chromium-plated corner and end pieces, $\frac{3}{4}$ in. chromium-plated round pattern pillar taps, $1\frac{1}{4}$ in. overflow and chain, $1\frac{1}{2}$ in. waste with trap and vulcanite plug.

Inside Sizes

Overall Sizes

Length	Width	Depth	Length	Width	Height
5 ft. $5\frac{1}{2}$ in.	23 in.	17 in.	6 ft. 3 in.	$31\frac{3}{4}$ in.	$20\frac{3}{4}$ in.

No. B 6334 THE GLEN DEVON MINOR BATH

A luxury bath exactly similar to the above but of a size more suitable for the smaller bathroom.

Inside Sizes

Overall Sizes

Length	Width	Depth	Length	Width	Height
5 ft. 0 in.	$21\frac{1}{2}$ in.	17 in.	5 ft. 7 in.	29 in.	20 in.

The above bath can be supplied in white—and the following colours : Primrose, green, blue, old ivory, turquoise and pink.

NOTE.—If square pattern taps are required as shown in our illustration, these will be extra.

To preserve your bath's original lustre clean with Cellapuro.

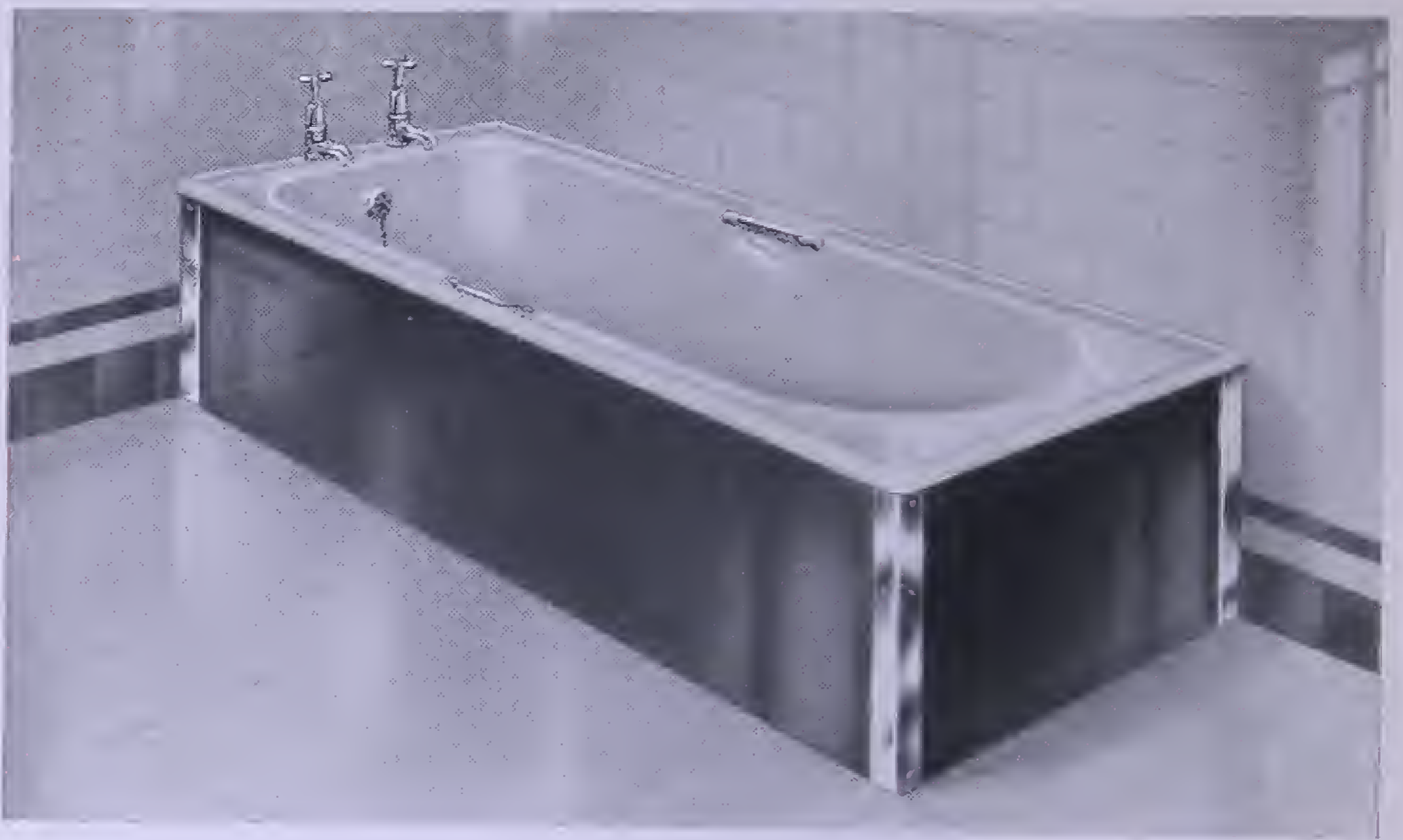

No. B 6335

THE SAFETY BATH

A reasonably priced cast-iron bath with $2\frac{3}{4}$ in. flat rim, fitted with two chromium-plated hand grips recessed into either side ; fitted with one front and one end black vitrolite glass panels having chromium-plated corner and end pieces. $\frac{3}{4}$ in. chromium-plated hot and cold pillar taps, $1\frac{1}{4}$ in. overflow and chain, $1\frac{1}{2}$ in. waste with trap and vulcanite plug.

Inside Sizes

Length	Width	Depth
5 ft. 0 in.	$22\frac{1}{2}$ in.	$17\frac{1}{2}$ in.
5 ft. 6 in.	$22\frac{1}{2}$ in.	$17\frac{1}{2}$ in.

Overall Sizes

Length	Width	Height
5 ft. 6 in.	28 in.	$22\frac{1}{2}$ in.
6 ft. 0 in.	28 in.	$22\frac{1}{2}$ in.

The above bath can be supplied porcelain-enamelled in white and in the following colours : Jade green, blue, ivory, primrose, turquoise, and pink.

Special prices quoted for quantities

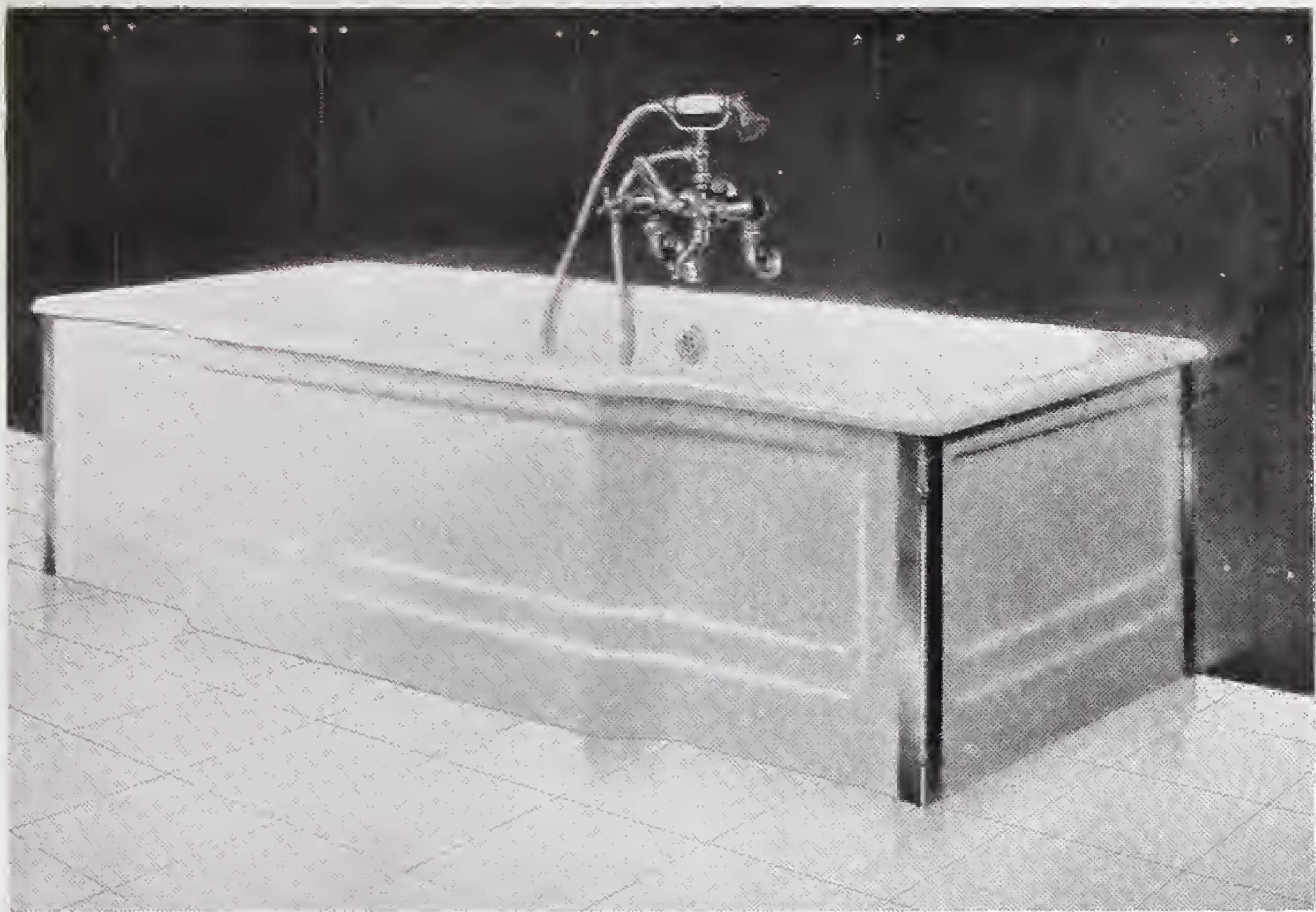

No. B 6336 THE NILE BATH

An equal ended cast-iron bath with centre outlet, porcelain-enamelled inside and on roll, with porcelain-enamelled cast-iron panels, chromium-plated corner and end pieces, waste and overflow holes only ; $\frac{3}{4}$ in. chromium-plated smooth body hot and cold wall supply fitting with centre supply nozzle, hand spray and chromium-plated rest ; $1\frac{1}{4}$ in. overflow and chain, $1\frac{1}{2}$ in. waste with trap and vulcanite plug.

Inside Sizes

Overall Sizes

Inside Sizes			Overall Sizes		
Length	Width	Depth	Length	Width	Height
5 ft. 1 in.	23 in.	15 in.	5 ft. 6 in.	30 in.	17 $\frac{1}{2}$ in.

The above bath can be supplied porcelain-enamelled white and in the following colours : Jade green, blue, ivory, primrose, amber, turquoise, and Pink.

NOTE.—A wall fitting of simpler design without a hand spray can be supplied if required.

Please refer to diagrams on page 26 when ordering Panel Baths.



No. B 4313 THE MAGNA BATH

A porcelain-enamelled cast-iron bath with $2\frac{3}{4}$ in. flat rim, fitted with one front and one end black vitrolite glass panels, $\frac{3}{4}$ in. chromium-plated hot and cold pillar taps, $1\frac{1}{4}$ in. overflow and chain, $1\frac{1}{2}$ in. waste with trap and vulcanite plug.

Inside Sizes

Overall Sizes

Inside Sizes			Overall Sizes		
Length	Width	Depth	Length	Width	Height
5 ft. 0 in.	$22\frac{1}{2}$ in.	$17\frac{1}{2}$ in.	5 ft. 6 in.	28 in.	$22\frac{1}{2}$ in.
5 ft. 6 in.	$22\frac{1}{2}$ in.	$17\frac{1}{2}$ in.	6 ft. 0 in.	28 in.	$22\frac{1}{2}$ in.

The above bath can be supplied porcelain-enamelled white and in the following colours: Jade green, blue, ivory, primrose, amber, turquoise, and pink.

— Special prices quoted for quantities —

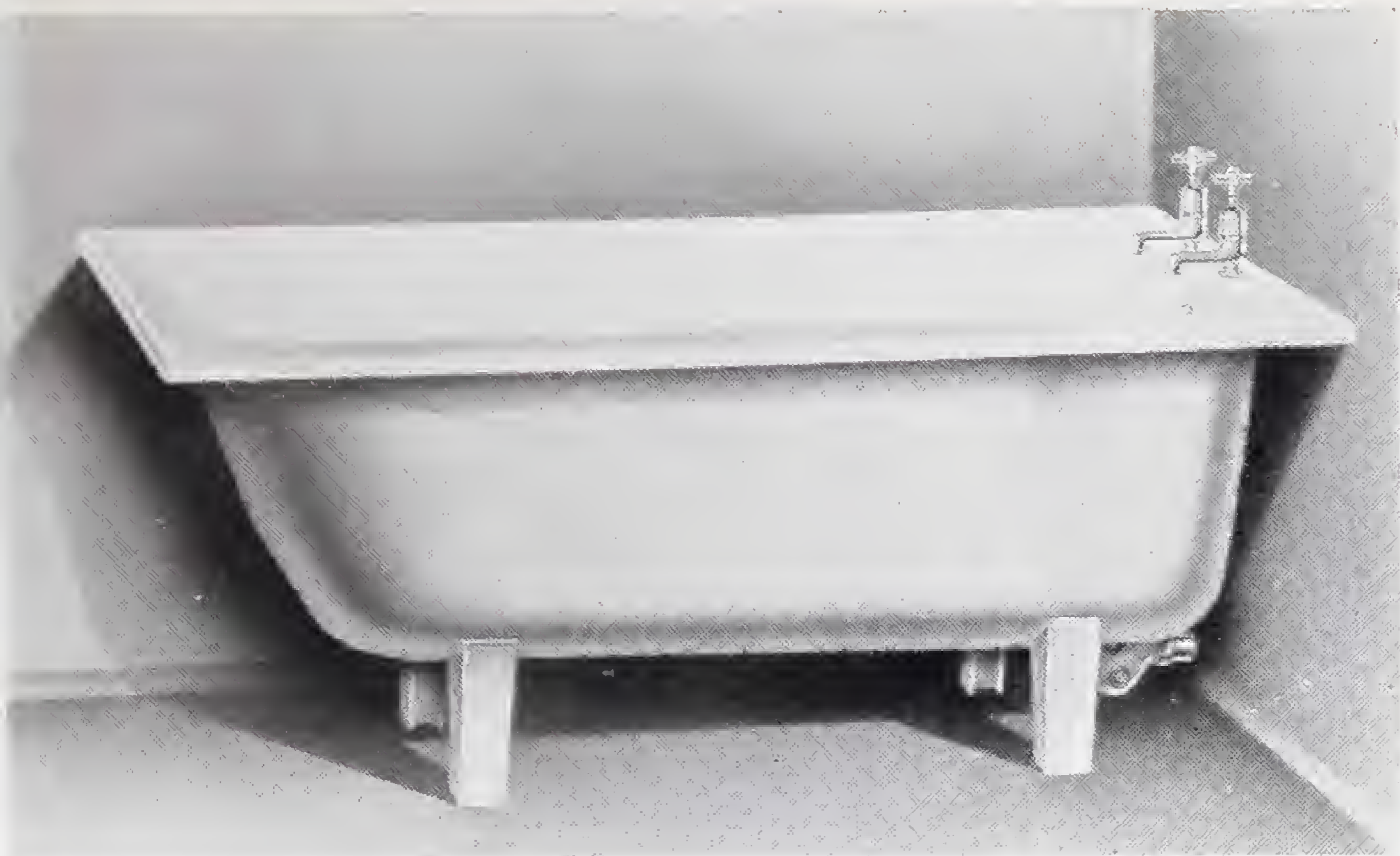

No. B 4315 THE ARCTIC BATH

This rectangular topped cast-iron bath has been specially designed to suit bathrooms where space is limited and also as a water saver ; porcelain-enameled inside and on rim, plain painted outside. Including $\frac{3}{4}$ in. chromium-plated smooth body hot and cold pillar taps, $1\frac{1}{4}$ in. overflow and chain, $1\frac{1}{4}$ in. waste with trap and vulcanite plug.

Inside Sizes

Overall Sizes

Inside Sizes			Overall Sizes		
Length	Width	Depth	Length	Width	Height
4 ft. $7\frac{1}{2}$ in.	21 in.	17 in.	5 ft 1 in.	25 in.	22 in.

Suitable panels can be supplied for the above bath in plain asbestos, glazed hardboard, or vitrolite glass.

This bath can be supplied in white and the following colours : Jade green, blue, ivory, primrose, amber, turquoise, and pink.

— Special prices quoted for quantities —

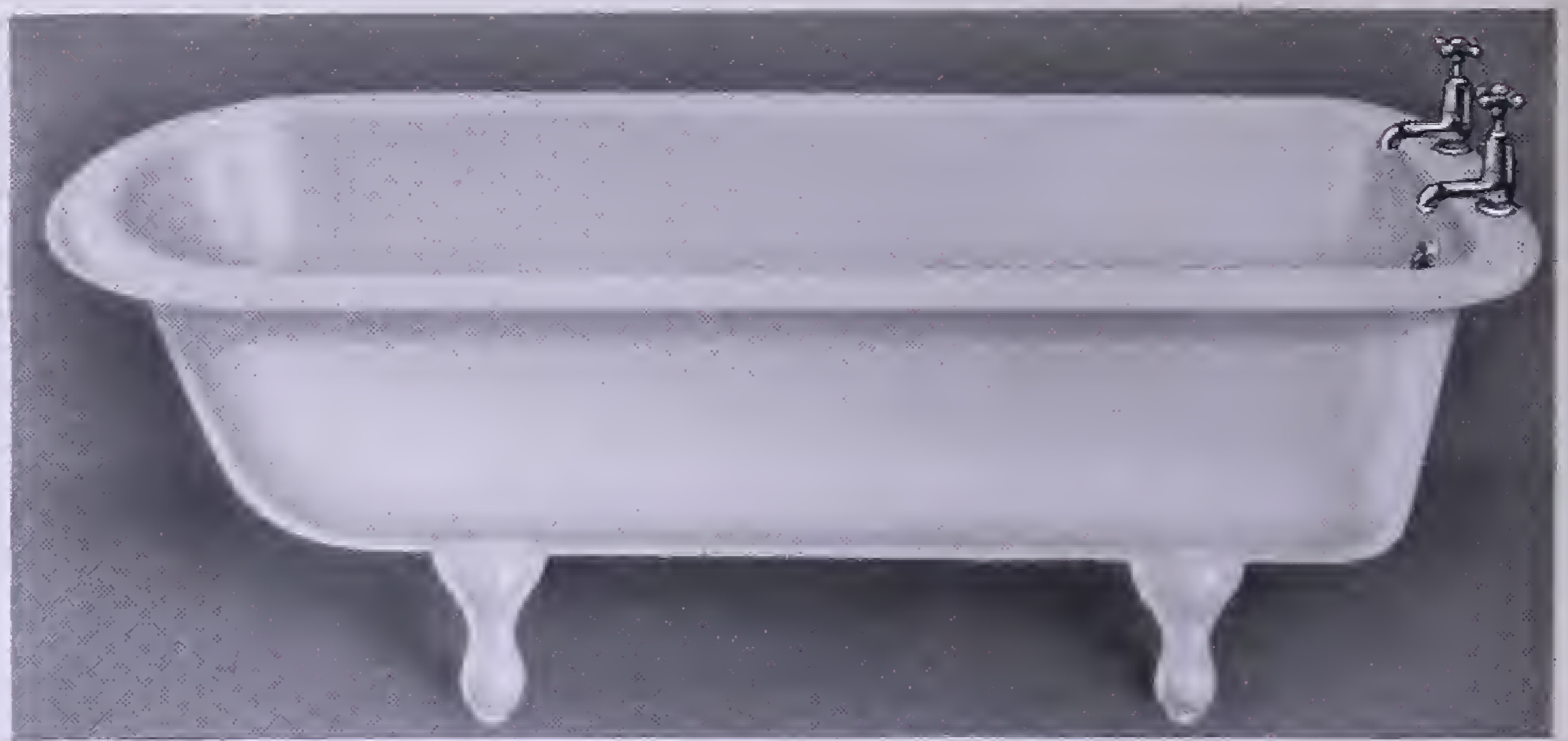

ROLL EDGE BATHS

Cast-iron with parallel sides, white porcelain-enamelled inside and over roll, plain painted outside, with detachable feet. Fittings illustrated are $\frac{3}{4}$ in. chromium-plated hot and cold pillar valves, $1\frac{1}{4}$ in. overflow and chain, $1\frac{1}{4}$ in. waste with trapped connection and vulcanite plug.

DIMENSIONS :

Inside Sizes			Roll	Overall Sizes	
Length	Width	Depth		Length	Width
No. B 4305					
3 ft. 6 in.	23 in.	17 in.	3 in.	4 ft. 0 in.	29 in.
4 ft. 0 in.	23 in.	17 in.	3 in.	4 ft. 6 in.	29 in.
4 ft. 6 in.	23 in.	17 in.	3 in.	5 ft. 0 in.	29 in.
† 5 ft. 0 in.	23 in.	17 in.	3 in.	5 ft. 6 in.	29 in.
† 5 ft. 6 in.	23 in.	17 in.	3 in.	6 ft. 0 in.	29 in.
No. B 4306					
† 5 ft. 0 in.	22 in.	17 in.	$2\frac{1}{2}$ in.	5 ft. 5 in.	27 in.
† 5 ft. 6 in.	22 in.	17 in.	$2\frac{1}{2}$ in.	5 ft. 11 in.	27 in.
No. B 4307					
4 ft. 6 in.	22 in.	17 in.	2 in.	4 ft. 10 in.	26 in.
5 ft. 0 in.	22 in.	17 in.	2 in.	5 ft. 4 in.	26 in.
5 ft. 6 in.	22 in.	17 in.	2 in.	5 ft. 10 in.	26 in.

Baths marked † are supplied with flat roll and other patterns with round roll.

Special prices quoted for quantities



No. B 4317 SITTING BATH

The ideal bath for all circumstances where the utmost economy of space is necessary. Rectangular-topped with 2 in. rim, white porcelain-enamelled inside and over rim. $\frac{3}{4}$ in. chromium-plated smooth-body hot and cold pillar taps, $1\frac{1}{4}$ in. overflow and chain, $1\frac{1}{4}$ in. waste with trapped connection and vulcanite plug. ($1\frac{1}{2}$ in. waste extra.)

Inside Sizes

Overall Sizes

Inside Sizes				Overall Sizes		
Length	Width	Depth at foot end	Depth at seat end	Length	Width	Height
3 ft. $0\frac{1}{2}$ in.	$23\frac{1}{4}$ in.	24 in.	$15\frac{1}{2}$ in.	3 ft. $6\frac{1}{2}$ in.	$27\frac{1}{2}$ in.	30 in.

Suitable panels in vitrolite glass or glazed hardboard can be supplied for this bath.

To preserve your bath's original lustre clean with Cellapuro.

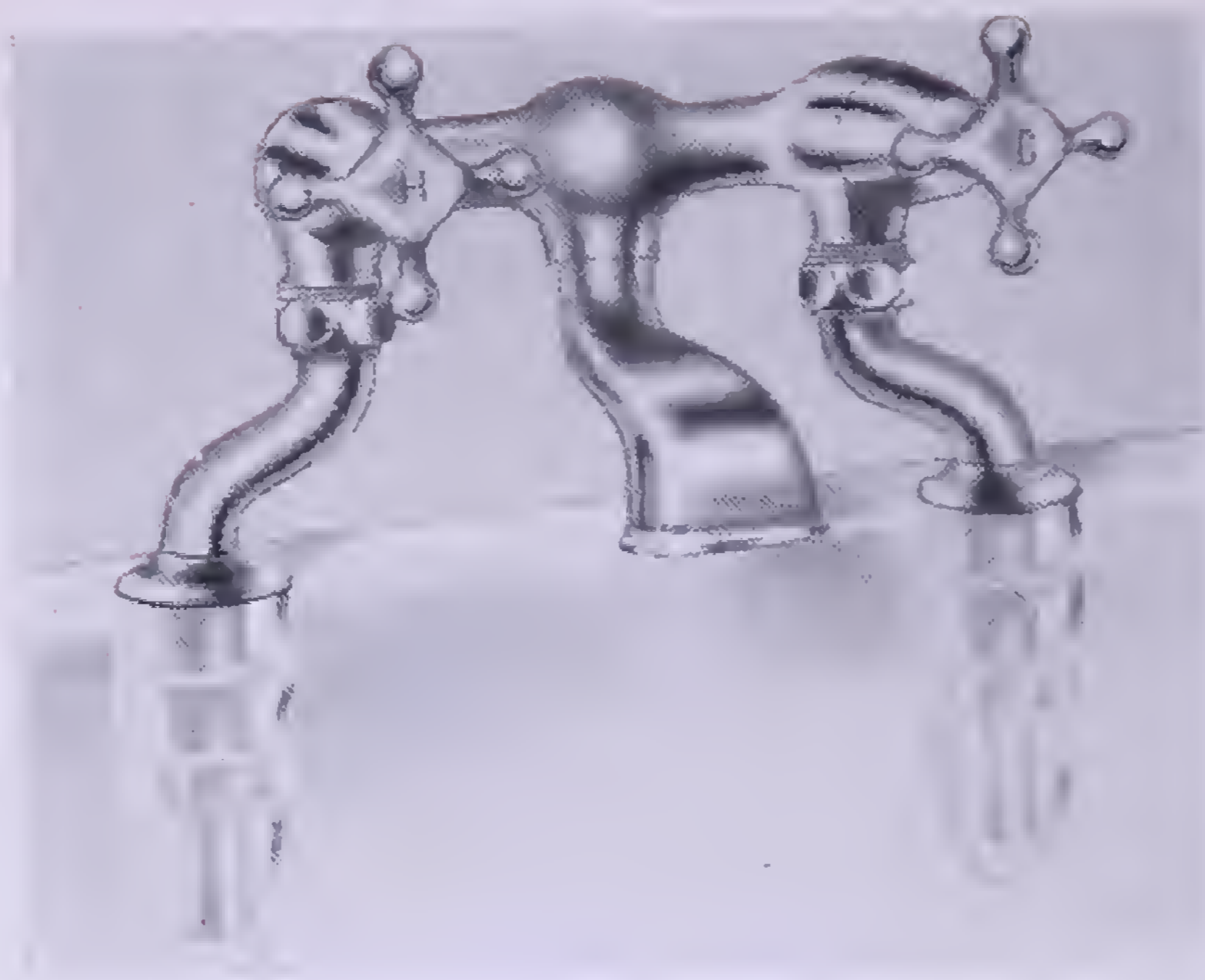

No. B 4376
**BATH SUPPLY
FITTING**

$\frac{3}{4}$ in. chromium-plated BS 1010 hot and cold supply valves with adjustable swivelling unions and single outlet nozzle. Fitting has baffle plate in mixing chamber.

No. B 4372
UNIVERSAL BALL JOINT SHOWER HEAD
Chromium-plated

Extremely economical in water consumption whilst ensuring a full drenching shower. The disc can be automatically drawn forward for flushing to remove silt.

Diameter across face, $1\frac{1}{2}$ in., screwed $\frac{1}{2}$ in. female iron.

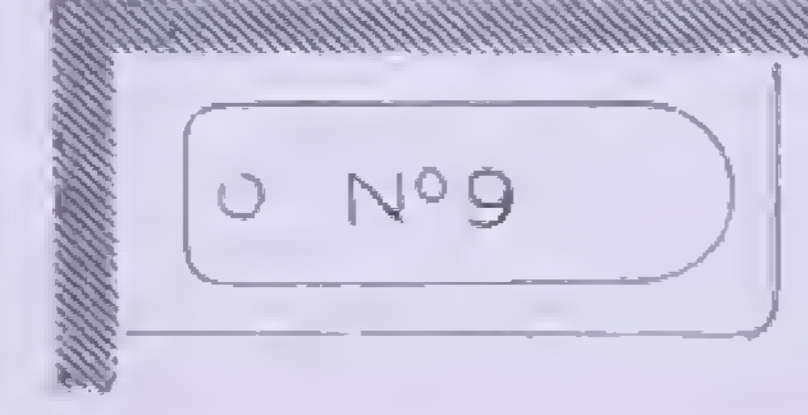
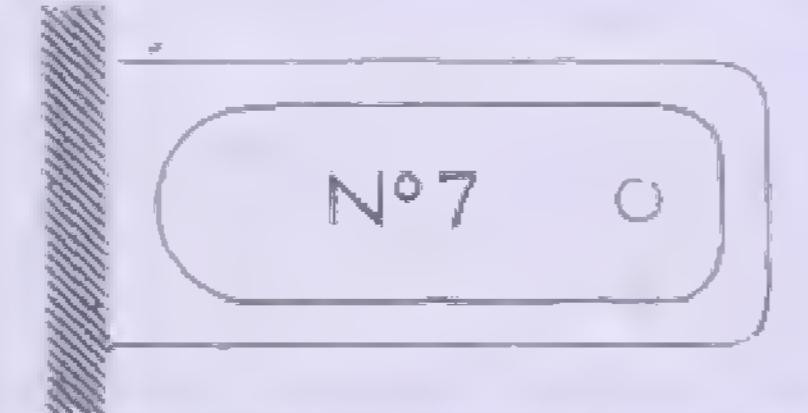
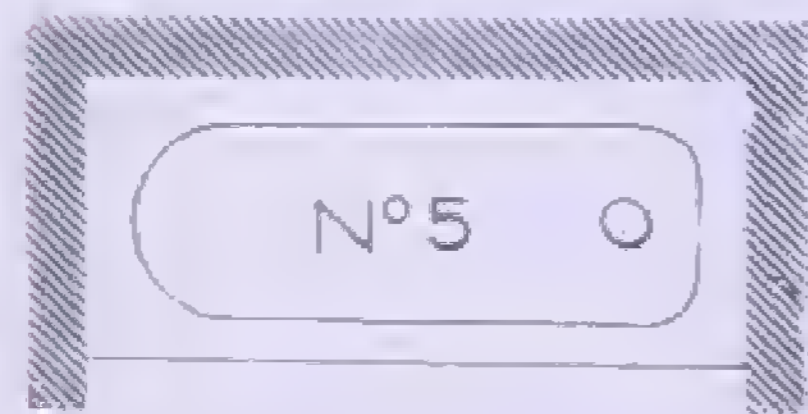
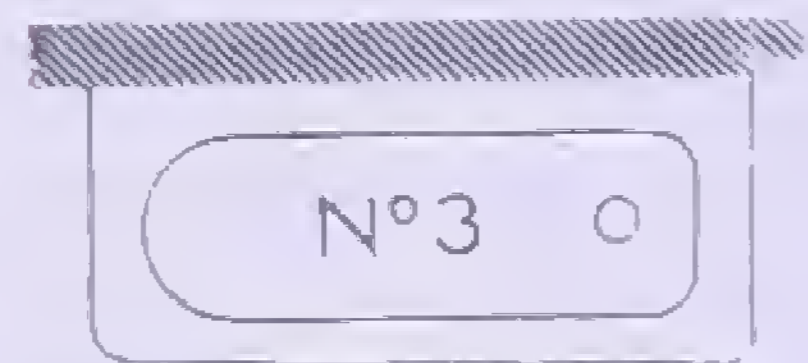
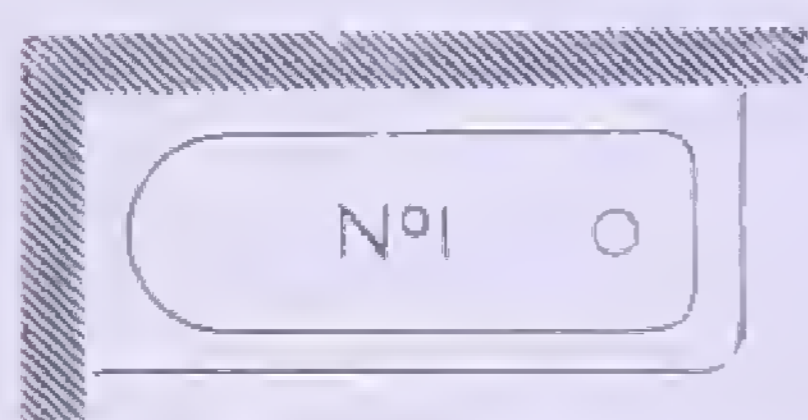

**DIAGRAMS
SHOWING
POSITIONS OF
PANELLED
BATHS**

**WHEN
ORDERING**
any panelled bath in
this list a reference
to these diagrams will
save errors and
unnecessary delay.

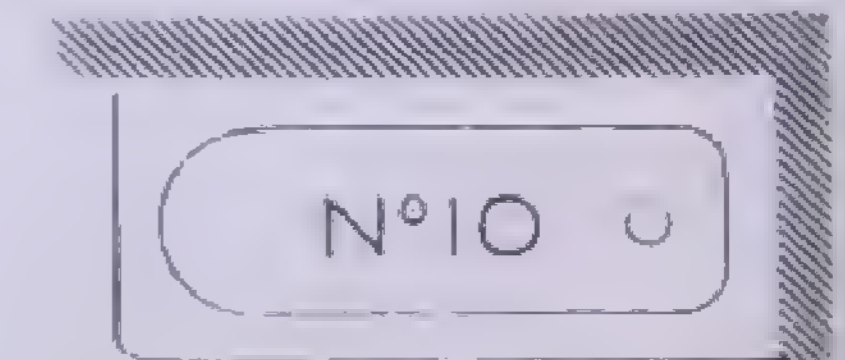
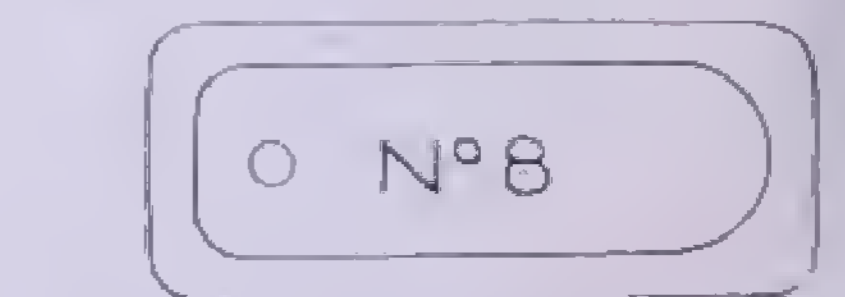
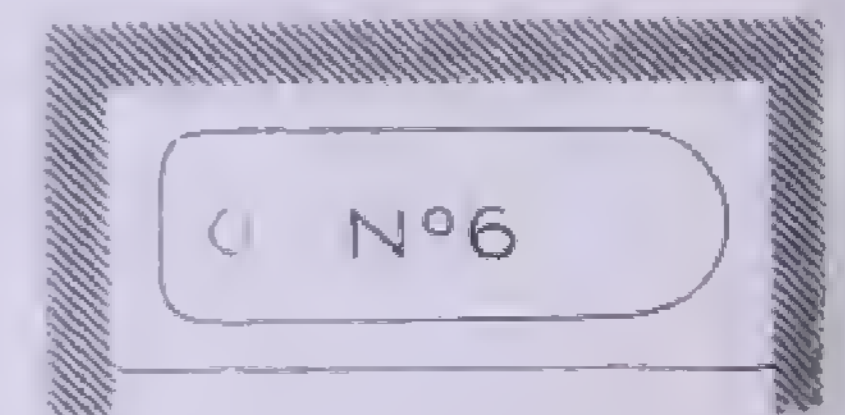
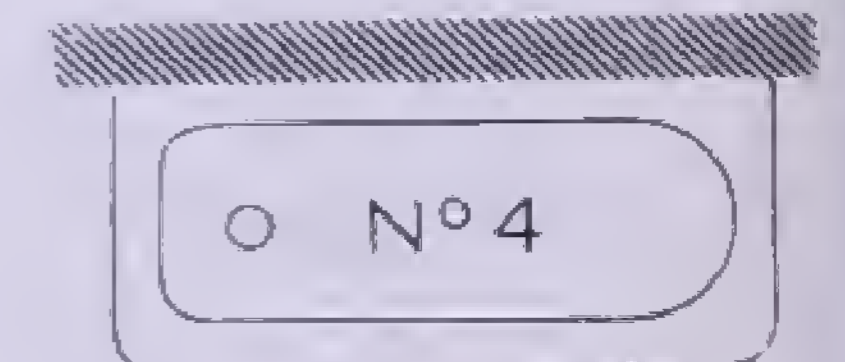
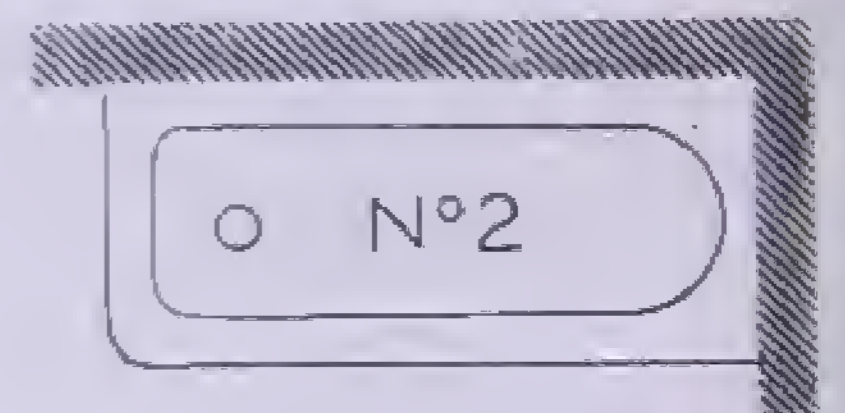



No. B 4373

BATH SUPPLY AND
SPRAY FITTING

$\frac{3}{4}$ in. chromium-plated
BS 1010 hot and cold control
valves with adjustable pillars,
flexible metallic tubing, hand
spray, and special pattern
hook.

No. B 4374

CONCEALED BATH
SUPPLY FITTINGS

$\frac{3}{4}$ in. chromium-plated
BS 1010 hot and cold valves
with engraved heads and
cast spout projecting $4\frac{3}{4}$ in.
from wall to inside of mouth.

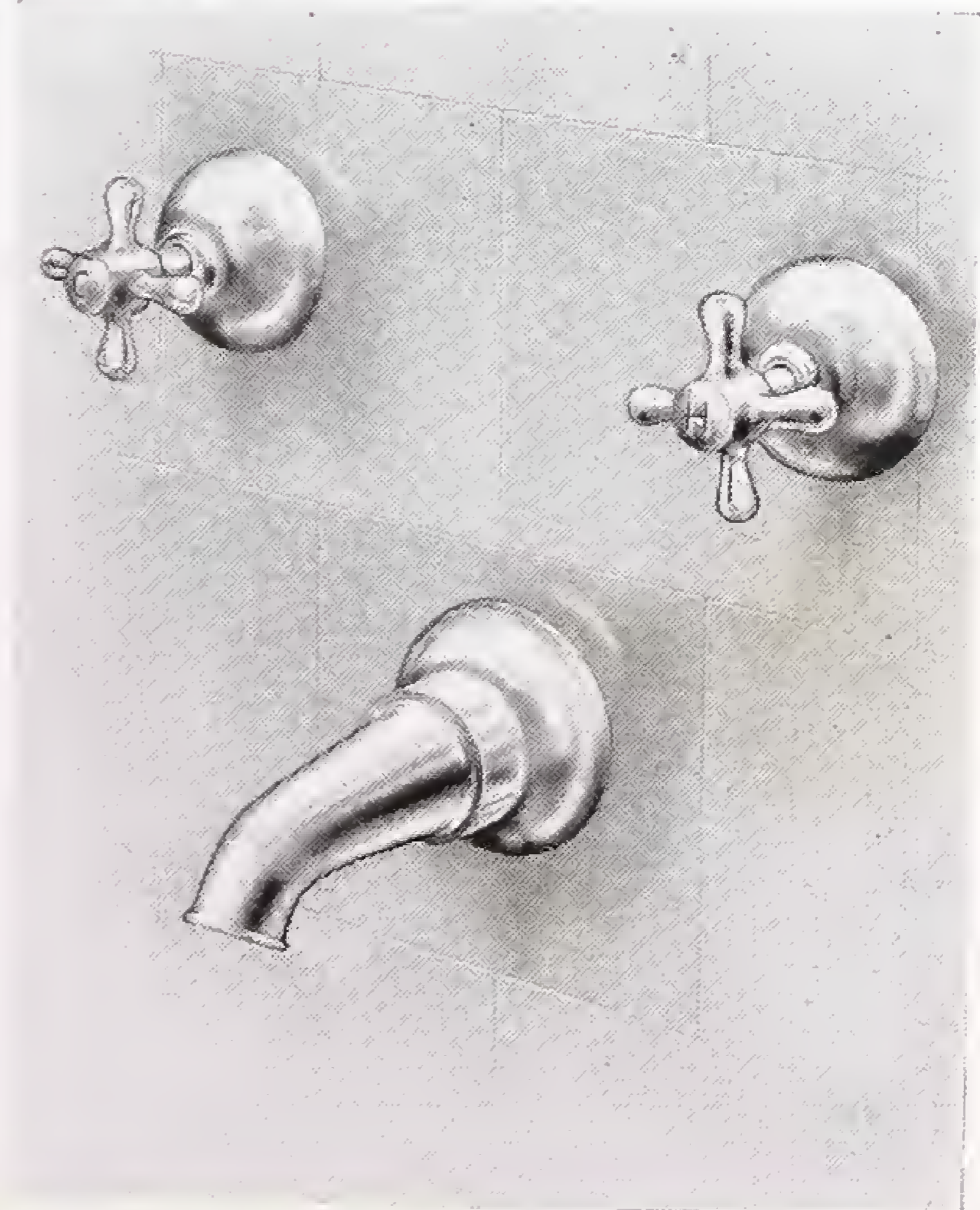



No. B 4381

**CONCEALED SHOWER
FITTINGS**

For fixing behind tiles, with $\frac{1}{2}$ in. BS 1010 chromium-plated hot and cold Easyclean supply valves and shower bracket screwed $\frac{1}{2}$ in. male iron with loose wall plate, universal ball joint shower head.

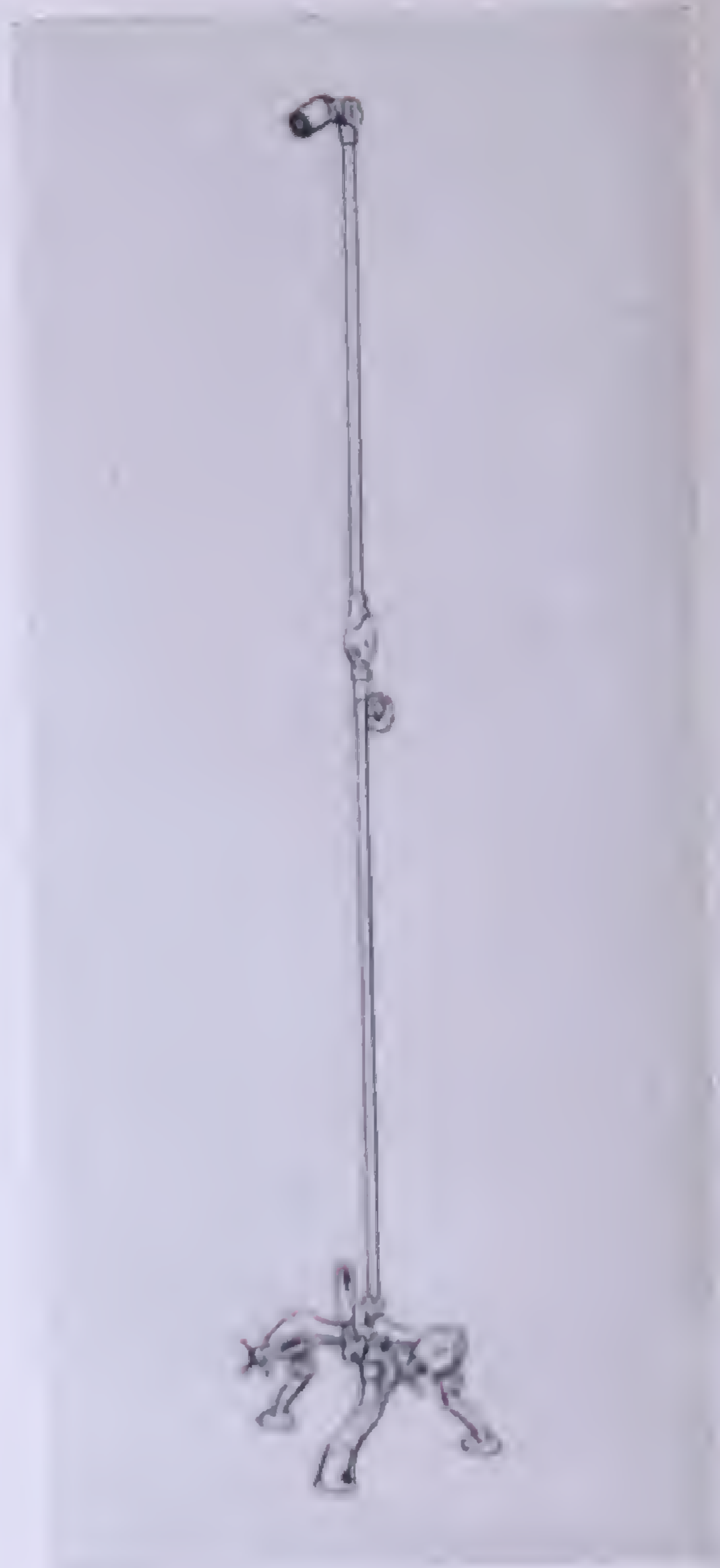

No. B 4380

**ADJUSTABLE BATH
SHOWER**

With $\frac{3}{4}$ in. BS 1010 chromium-plated hot and cold screw-down valves with adjustable centres, dividing lever, upright tube with wall support and adjustable shower arm with universal ball joint water conserving shower head.

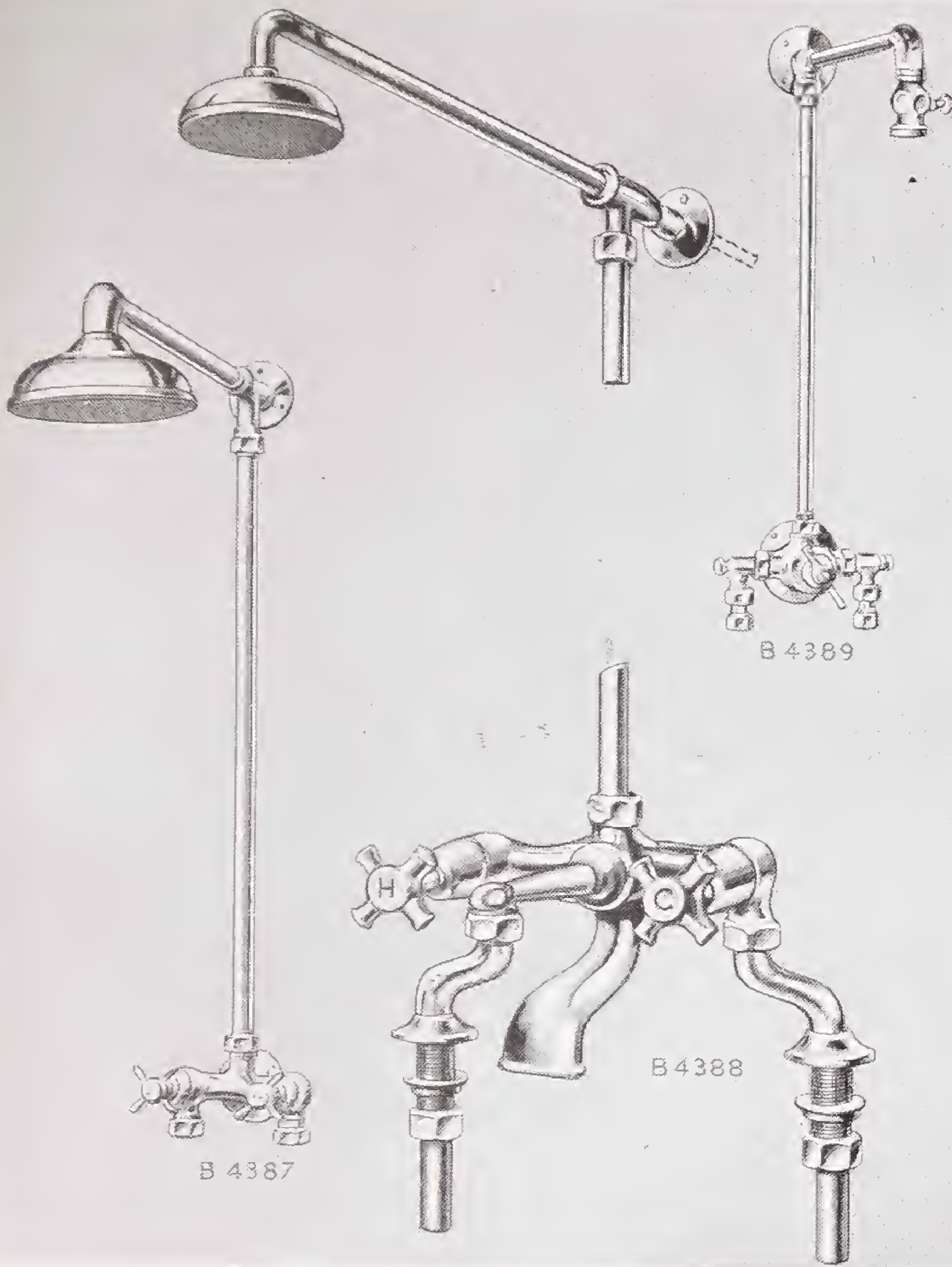

SHOWERS

No. B4387. With $\frac{1}{2}$ in. Hot and Cold Supply Fitting to BS 1010 Spcfn., inlets for copper or lead pipe ; with riser pipe, 6 in. rose and 16 $\frac{1}{2}$ in. shower arm. Chromium plated.

No. B4388. With $\frac{3}{4}$ in. hot and cold bath and shower fitting to BS 1010 Spcfn., fully adjustable unions, 5-ft. riser pipe with adjustable arm and 5 in. rose. Chromium-plated.

No. B4389. With $\frac{1}{2}$ in. mixing valve marked 'HOT' 'TEPID' 'COLD' and 'SHUT' with variable connections for copper or lead pipe, with riser pipe, 18 in. shower arm and 'Economic' sprayer to give fine, medium, or heavy spray. Chromium-plated.



No. B 4382

**SINGLE SWING SHOWER
SCREEN**

Made from heavily extruded brass section with rubber Squeegee section for wall and bath contacts. Standard size 4 ft. 6 in. high \times 2 ft. 3 in. wide with $\frac{1}{4}$ in. polished plate or $\frac{1}{4}$ in. obscured rolled cast glass.

No. B 4383

**SINGLE SWING SHOWER
SCREEN**

Made specially to suit drop front square top baths.

Please send full-sized template of bath rim when ordering, stating thickness of tile overhang.

Description and Size exactly as No. B4382 above.



No. B 4384. CURTAIN RING

No. B 4385
SHOWER CURTAIN

Chromium-plated 24 in. dia. curtain ring with centre bar and connection for shower fitting with banjo curtain hooks.

The shower curtain illustrated is printed plastic material 6 ft. \times 6 ft. We have a wide range of materials available.

Most of the shower fittings illustrated can be fitted with a curtain ring similar to the above.



No. B 4386

SHOWER BATH DOOR

A luxury shower bath door with extruded brass framing. Adjustable jamb to take up slight difference in width of opening. Fitted with continuous hinge and double ball catch and water reflector. Glazed with $\frac{1}{4}$ in. plate glass or $\frac{1}{4}$ in. obscured rolled cast glass.

Standard size to suit opening 6 ft. 6 in. high \times 2 ft. 2 in. wide.

Please state hand required.





No. B 6294

PEDESTAL LAVATORY

Best White-glazed Vitreous China

A fine quality lavatory with side shelves and flat top, of generous proportions for the larger type of residence.

$\frac{1}{2}$ in. chromium-plated hot and cold control valves with single centre supply nozzle, $1\frac{1}{4}$ in. waste with pull-up operation.

Overall Size :

31 in. X 19 in.

This lavatory can also be supplied in a range of colours including peach, old ivory, primrose, amber, jade green, turquoise, jubilee blue, and hyacinth.



No. B 6295

**PEDESTAL
LAVATORY**

Best White-glazed
Earthenware.

A deep fascia lavatory
with high back and bold
modern lines.

$\frac{1}{2}$ in. chromium-plated hot
and cold pillar taps, $1\frac{1}{4}$
in. waste with plug and
chain.

Overall Size :

24 in. \times 20 in.

No. B 6296 PEDESTAL LAVATORY
Best White-glazed Earthenware.



A perfectly matched
design for dipped
front baths, having a
flat top, useful side
platforms and a
raised rim to prevent
splashing.

$\frac{1}{2}$ in. chromium-plated
hot and cold pillar
taps, $1\frac{1}{4}$ in. waste
with plug and chain.

Overall Sizes :

25 in. \times 18 in.

27 in. \times 19 in.

NOTE.—Chromium-plated supply pipes and trap extension to wall, as illustrated, can also be supplied at an extra charge. *The above Lavatories can also be supplied in colours.*



No. B 6299
PEDESTAL
LAVATORY

Best White-glazed
Earthenware.

Square design, without back
skirting.

$\frac{1}{2}$ in. chromium-plated hot
and cold pillar taps, $1\frac{1}{4}$ in.
waste with plug and chain.

Overall Sizes :

24 in. \times 20 in.

27 in. \times 22 in.

No. B 6254
PEDESTAL
LAVATORY

Best White-glazed
Earthenware

Bold design, without back
skirting.

$\frac{1}{2}$ in. chromium-plated hot
and cold pillar taps, $1\frac{1}{4}$ in.
waste with plug and chain.

Overall Sizes :

24 in. \times 20 in.

27 in. \times 22 in.



The above Lavatories can also be supplied in colours



No. B 4365
PEDESTAL
LAVATORY

Best White-glazed
Earthenware.

Square design with back
skirting and integral shelf.
 $\frac{1}{2}$ in. chromium-plated hot
and cold pillar taps, $1\frac{1}{4}$ in.
waste with plug and chain.

Overall Sizes :

22 in. \times 16 in.

25 in. \times 18 in.

27 in. \times 19 in.

No. B 6256
PEDESTAL
LAVATORY

Best White-glazed
Earthenware.

Square design with back
skirting and platform at back.
 $\frac{1}{2}$ in. chromium-plated hot
and cold pillar taps, $1\frac{1}{4}$ in.
waste with plug and chain.

Overall Sizes :

22 in. \times 16 in.

25 in. \times 18 in.

27 in. \times 19 in.



The above Lavatories can also be supplied in colours

No. B 6300 BRACKET LAVATORY



White-glazed Vitreous
China.

Strong, modern design, with
slot overflow and back skirt-
ing. Supported on white
porcelain-enamelled cast-iron
towel rail brackets.

$\frac{1}{2}$ in. chromium-plated hot
and cold pillar taps, $1\frac{1}{4}$ in.
waste with plug and chain.

Overall Sizes: 22 in. \times 16 in. 25 in. \times 18 in.

Vitreous China Ware

No. B 6301
PEDESTAL
LAVATORY

White-glazed
Vitreous China.

Rounded design with back
skirting and generous size
basin.

$\frac{1}{2}$ in. chromium-plated hot
and cold pillar taps, $1\frac{1}{4}$ in.
waste with plug and chain.

Overall Sizes :
22 in. \times 16 in.
25 in. \times 18 in.



*Both the above basins have the overflow at the front
The above Lavatories can also be supplied in colours*

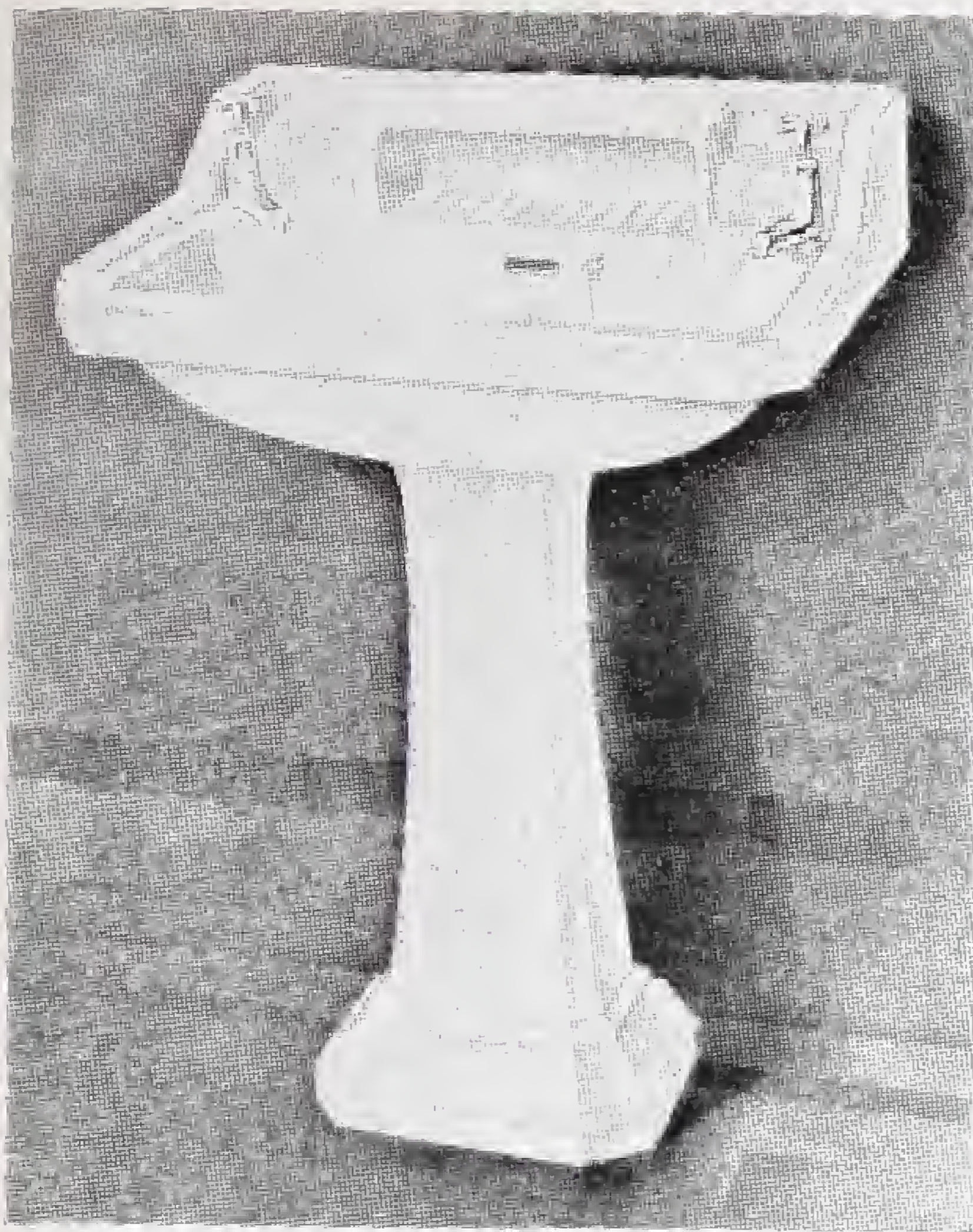

No. B 6297
PEDESTAL
LAVATORY

Best White-glazed
Earthenware.

Square design with back
skirting and large centre
shelf; smaller stepped
shelves on either side
with recessed soap and
brush holder.

$\frac{1}{2}$ in. chromium-plated
hot and cold pillar taps,
 $1\frac{1}{4}$ in. waste with plug and
chain.

Overall Sizes :
22 in. \times 16 in.
25 in. \times 18 in.

No. B 6298
HAIRDRESSERS' PEDESTAL LAVATORY

Best White-glazed
Earthenware.

A deep fascia lavatory with
bowed cut-down front for
shampoo purposes; can also
be supplied with a hole for
hose guide in the back
right-hand corner. Complete
with $1\frac{1}{4}$ in. chromium-plated
waste with plug and chain.

Overall Sizes :
22 in. \times 16 in.
25 in. \times 18 in.



Suitable shampoo fittings are illustrated on page 39

No. B 6306
HAIRDRESSERS' BRACKET LAVATORY

Best quality white glazed vitreous china

A new pattern lavatory with front overflow and anti-splash rim specially designed for shampoo purposes. Special painted cast-iron wall supports. $\frac{1}{2}$ in. hot and cold mixer fitting for screwing to wall, with flexible metallic tube, hand spray and wall hook; $1\frac{1}{4}$ in. waste with plug and chain and P trap to wall with covering flange.

All fittings chromium plated

Overall Size: 24 in. X 20 in.



NOTE.—Splashbacks of suitable types can be offered to suit individual requirements (extra).

No. B 6307
HAIRDRESSERS' BRACKET LAVATORY



Overall Size: 24 in. X 20 in.

Best quality white glazed heavy earthenware.

A recessed front design with anti-splash rim and large bowl which provides ample working space and head room.

Supported on white porcelain-enamelled cast-iron towel rail brackets.

$\frac{1}{2}$ in. chromium-plated wall supply fitting having hot and cold control valves, flexible tube and hand spray, $1\frac{1}{4}$ in. lift-up plug waste.

No. B 6308
HAIRDRESSERS' BRACKET LAVATORY

Best quality white glazed earthenware

A deep fascia lavatory with bowed cut-down front for shampoo purposes. Supported on painted or white-porcelain enamelled cast-iron towel rail brackets. $1\frac{1}{4}$ in. chromium-plated waste with plug and chain; can also be supplied with a hole for hose guide in the back right-hand corner.

Overall Sizes:

22 in. X 16 in.

25 in. X 18 in.





No. B 4413

SHAMPOO FITMENT

$\frac{1}{2}$ in. chromium-plated B.S. 1010 hot and cold supply fitting with chromium-plated flexible metallic tube, hand-spray and wall hook.

No. B 4417

SHAMPOO FITMENT

$\frac{1}{2}$ in. chromium-plated B.S. 1415 mixing valve with metal dial plate calibrated for temperature. Bent unions on inlets, outlet fitted with flexible metallic tube, hand spray and wall hook.



No. B 4416

TRU-FLO SHAMPOO SPRAY

A De Luxe Model embodying special bulb tap connexions for bath or basin taps, three-way piece and special high-grade rubber tubing.

Available in Pink, Blue, Green, and White, with special hand grip and spray head to match.



Mirrors and all equipment for Hairdressers' Saloons quoted for on application.



No. B 6309
STAND
LAVATORY

Best White-glazed
Earthenware

Square pattern with long integral shelf and soap trays, slot overflow.

$\frac{1}{2}$ in. chromium-plated hot and cold pillar taps, $1\frac{1}{4}$ in. waste with plug and chain and chromium-plated bottle trap.

Chromium-plated brass round tube stand with $\frac{3}{8}$ in. legs and towel rails.

Overall Sizes :

22 in. \times 16 in.
25 in. \times 18 in.
27 in. \times 19 in.

No. B 6310
STAND
LAVATORY

Best White-glazed
Earthenware

An attractive pattern with dipped front and back skirt-ing.

$\frac{1}{2}$ in. chromium-plated hot and cold pillar taps with special high noses, $1\frac{1}{4}$ in. waste with plug and chain, chromium-plated bottle trap with plastic base.

Chromium-plated brass lavatory stand with legs of special shape and side towel rails.

Overall Sizes :

22 in. \times 16 in.
25 in. \times 18 in.
27 in. \times 19 in.





No. B 6311

**STAND
LAVATORY**

White-glazed Vitreous
China.

A very strong square pattern
with back skirting and slot
overflow.

$\frac{1}{2}$ in. chromium-plated hot
and cold pillar taps, $1\frac{1}{4}$ in.
waste with plug and chain.
Unpolished cast aluminium
stand with legs to floor,
front towel rail and wall
brackets.

Overall Sizes :

22 in. \times 16 in.

25 in. \times 18 in.

No. B 6312

**STAND
LAVATORY**

Best White-glazed
Earthenware.

A new design with rounded
front, back skirting and slot
overflow.

$\frac{1}{2}$ in. chromium-plated hot
and cold pillar taps, $1\frac{1}{4}$ in.
waste with plug and chain.
Plain painted cast-iron stand
with legs to floor and wall
stays.

Overall Sizes :

22 in. \times 16 in.

25 in. \times 18 in.

27 in. \times 19 in.



No. B 6302

BRACKET LAVATORY

Best White-glazed Earthenware.



A novel pattern with dipped front to match the modern bath; supported on white porcelain-enamelled cast-iron towel rail brackets.

$\frac{1}{2}$ in. chromium-plated hot and cold pillar taps, $1\frac{1}{4}$ in. waste with plug and chain.

Overall Sizes :

22 in. \times 16 $\frac{1}{2}$ in.

25 in. \times 18 in.

27 in. \times 19 in.

No. B 6262

BRACKET LAVATORY

Best White-glazed Earthenware.



Square pattern Basin with back skirting, supported on white porcelain-enamelled cast-iron towel rail brackets.

$\frac{1}{2}$ in. chromium-plated hot and cold pillar taps, $1\frac{1}{4}$ in. waste with plug and chain.

Overall Sizes :

22 in. \times 16 in.

25 in. \times 18 in.

27 in. \times 19 in.

No. B 6265

BRACKET SHELF LAVATORY

Best White-glazed Earthenware.



Square pattern Basin with back skirting and integral shelf, supported on white porcelain-enamelled cast-iron towel rail brackets.

$\frac{1}{2}$ in. chromium-plated hot and cold pillar taps, $1\frac{1}{4}$ in. waste with plug and chain.

Overall Sizes :

22 in. \times 16 in.

25 in. \times 18 in.

27 in. \times 19 in.

BRACKET LAVATORY BASINS
Best White-glazed Earthenware

No. B 6267

**SMALL ANGULAR
LAVATORY BASIN**

Including $\frac{1}{2}$ in. C.P. hot and cold taps, $1\frac{1}{4}$ in. waste with plug and chain (this basin is fixed to the wall by screws).

Size :
21 in. \times 21 in.

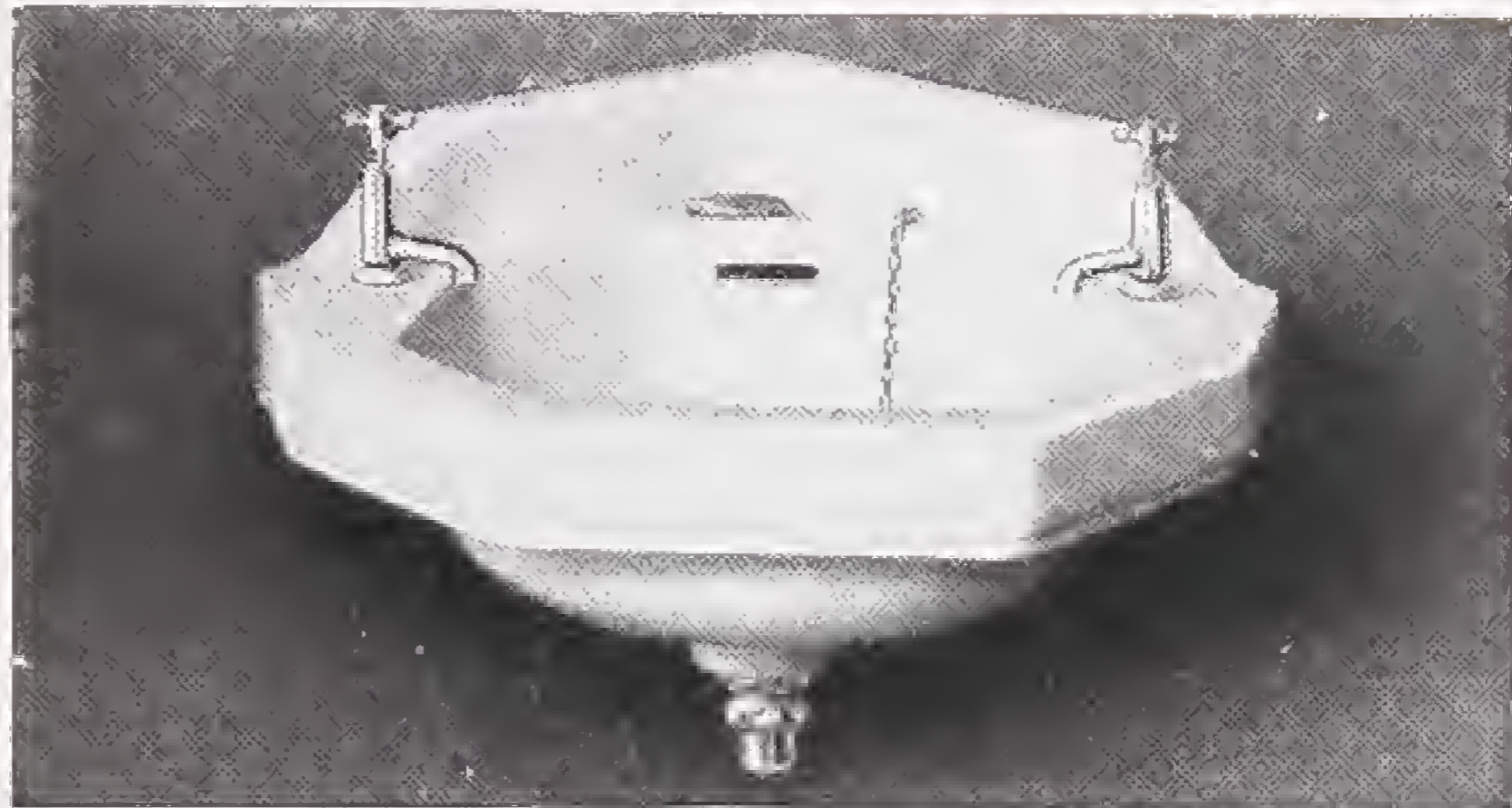

No. B 6264

LAVATORY BASIN
for confined spaces

Including $\frac{1}{2}$ in. C.P. hot and cold taps, $1\frac{1}{4}$ in. waste with plug and chain, and C.I. wall hangers.

Size :
18 in. \times 15 in.

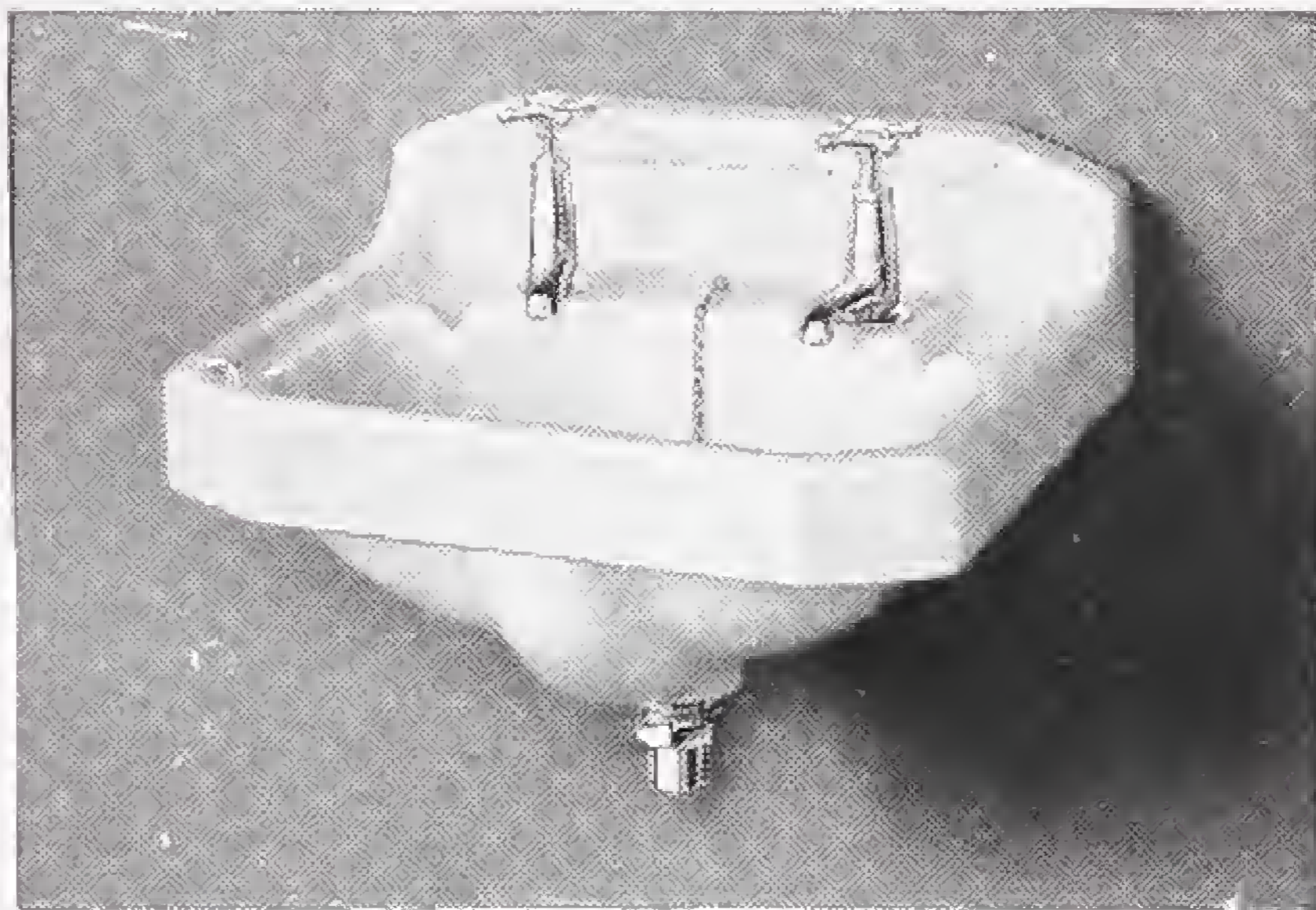

No. B 6263

LAVATORY BASIN
for Cloakrooms, etc.

Including $\frac{1}{2}$ in. C.P. hot and cold taps, $1\frac{1}{4}$ in. waste with plug and chain, and C.I. wall hangers.

Size :
26 in. \times 14 in.

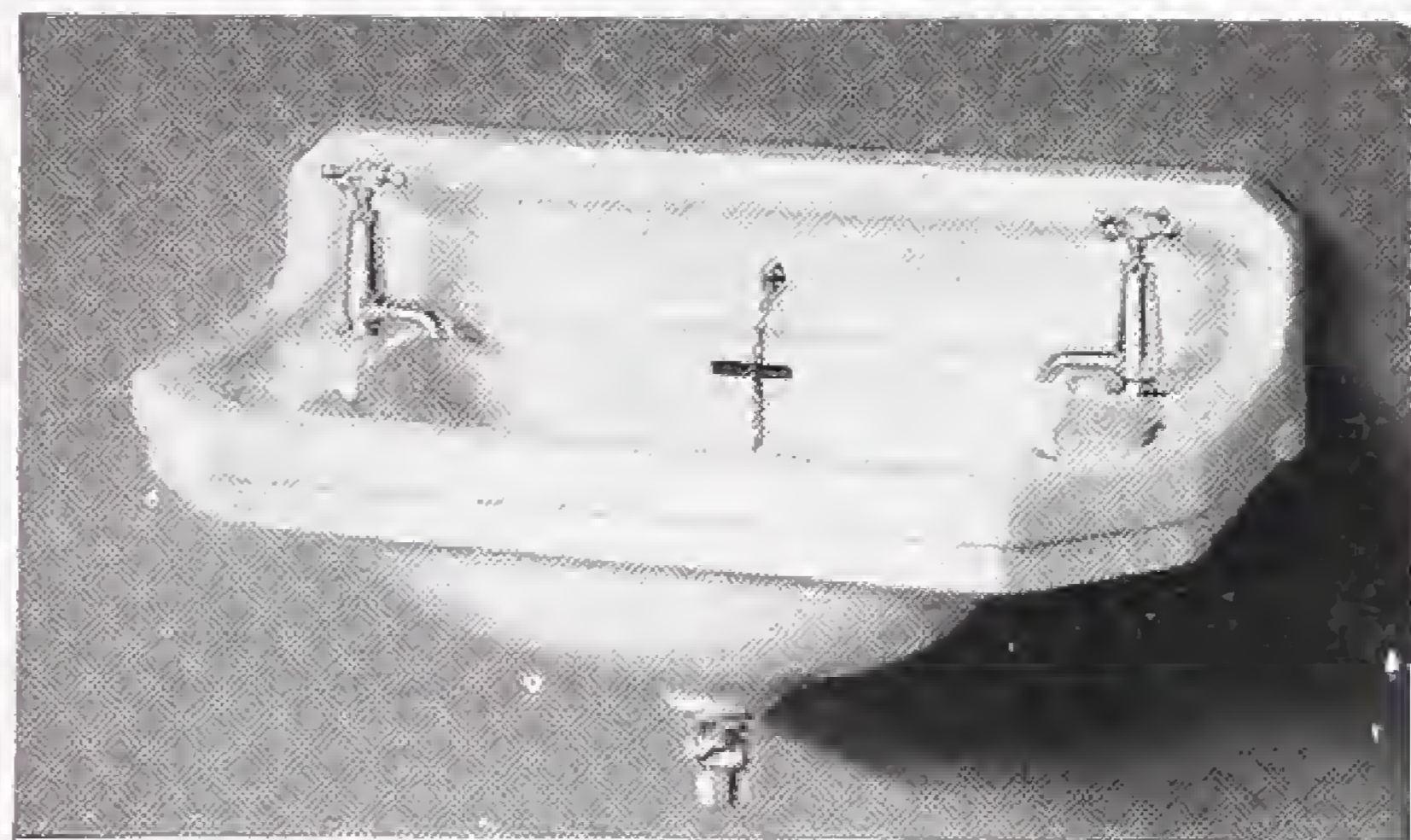

No. B 6266

**ANGULAR
LAVATORY BASIN**

Including $\frac{1}{2}$ in. C.P. hot and cold taps, $1\frac{1}{4}$ in. waste with plug and chain, and painted C.I. brackets.

Sizes :
24 in. \times 18 in.
27 in. \times 20 in.



No. B 6303
BRACKET LAVATORY

White Glazed Fireclay.
Standard Quality

Strong, modern design, with slot overflow and back skirting. Supported on white porcelain-enamelled cast-iron towel rail brackets. $\frac{1}{2}$ in. smooth-body chromium-plated hot and cold pillar taps, $1\frac{1}{4}$ in. waste with plug and chain.

Overall Sizes :

20 in. \times 16 in.
22 in. \times 16 in.
25 in. \times 18 in.



No. B 6304

BRACKET LAVATORY

Cast-iron white porcelain-enamelled with roll rim and back skirting, grid overflow and waste combined.

Supported on white porcelain-enamelled wall brackets.

$\frac{1}{2}$ in. smooth-body chromium-plated hot and cold pillar taps, $1\frac{1}{4}$ in. waste with plug and chain.

Overall Sizes : 22 in. \times 16 in. ; 25 in. \times 18 in.

No. B 6305
SURGEONS' LAVATORY

With soap trays, recessed outlet and anti-splash rim, $\frac{1}{2}$ in. hot and cold chromium-plated combined supply fitting with swan neck, anti-splash discharge and wrist-action levers ; $1\frac{1}{4}$ in. waste fitting with vulcanite stand pipe, $1\frac{1}{4}$ in. bottle trap with extension to wall and wall flange, white porcelain enamelled cast-iron cantilever brackets.

Overall Sizes :

24 in. \times 18 in.
24 in. \times 20 in.



No. B 1216
ROUND PLUG BASIN

White Earthenware

Sizes :

<i>Overall</i>	<i>Bowl</i>
18 in.	16 in.
17 in.	15 in.
16 in.	14 in.
15 in.	13½ in.
14 in.	12½ in.
13 in.	11½ in.
12 in.	10½ in.



A round plug basin for fitting beneath marble slab.
 Can be supplied with Combined overflow only.

No B 1218
**OVAL PLUG
 BASIN**

White Earthenware

Sizes

<i>Overall</i>	<i>Bowl</i>
23 × 17 in.	20¾ × 14¼ in.
20 × 15 in.	17¾ × 12¾ in.
16 × 13 in.	14 × 11 in.
14 × 12 in.	12 × 10 in.



An oval plug basin for fitting beneath marble slab.
 Can be supplied with Combined overflow only.

No B 6316
**OBLONG PLUG
 BASIN**

White Earthenware

Sizes:

<i>Overall</i>	<i>Bowl</i>
24 × 17½ in.	22 × 16 in.
22 × 17½ in.	20 × 16 in.
21½ × 16½ in.	19½ × 14½ in.



An oblong plug basin for fitting beneath marble slab.
 Can be supplied with Combined overflow only.

No. B 4481

LAVATORY RANGE

Best White-Glazed Earthenware

Comprising rectangular modern pattern basins with cut corners and back skirtings and loose overlap joints. Painted or white porcelain-enamelled cast-iron brackets to support.

$\frac{1}{2}$ in. chromium-plated hot and cold pillar taps, $1\frac{1}{4}$ in. wastes with plugs and chains.

Overall Sizes (each basin) : 22 in. \times 16 in. ; 25 in. \times 18 in. ; 27 in. \times 19 in.

No. B 6314

SCHOOL LAVATORY RANGE

White-Glazed Heavy Fireclay

Comprising basins each with anti-splash rim at front, soap tray, 3 in. back skirting, weir overflow fitted with C.P. brass grating and loose overlap joints ; painted or white porcelain-enamelled cast-iron brackets either to screw to wall or to build in.

$\frac{1}{2}$ in. chromium-plated hot and cold pillar taps, $1\frac{1}{4}$ in. waste fittings with plugs and chains. Supplied either in range form or with glazed ends for fixing singly.

These basins comply with B.S./M.O.E.

Overall Size (each basin) : 18 in. \times 12 in.

No. B 6315

LAVATORY RANGE

White-Glazed Heavy Fireclay

Comprising B.S.F.A. Standardized lavatory basins with slot overflows, corner tapholes, integral shelves, cut corners and loose overlap joints. Painted or white porcelain-enamelled cast-iron screw-to-wall brackets.

$\frac{1}{2}$ in. chromium-plated hot and cold pillar taps, $1\frac{1}{4}$ in. waste fittings with plugs and chains.

Overall Sizes (each basin) : 20 in. \times 16 in. ; 22 in. \times 16 in. ; 25 in. \times 18 in.

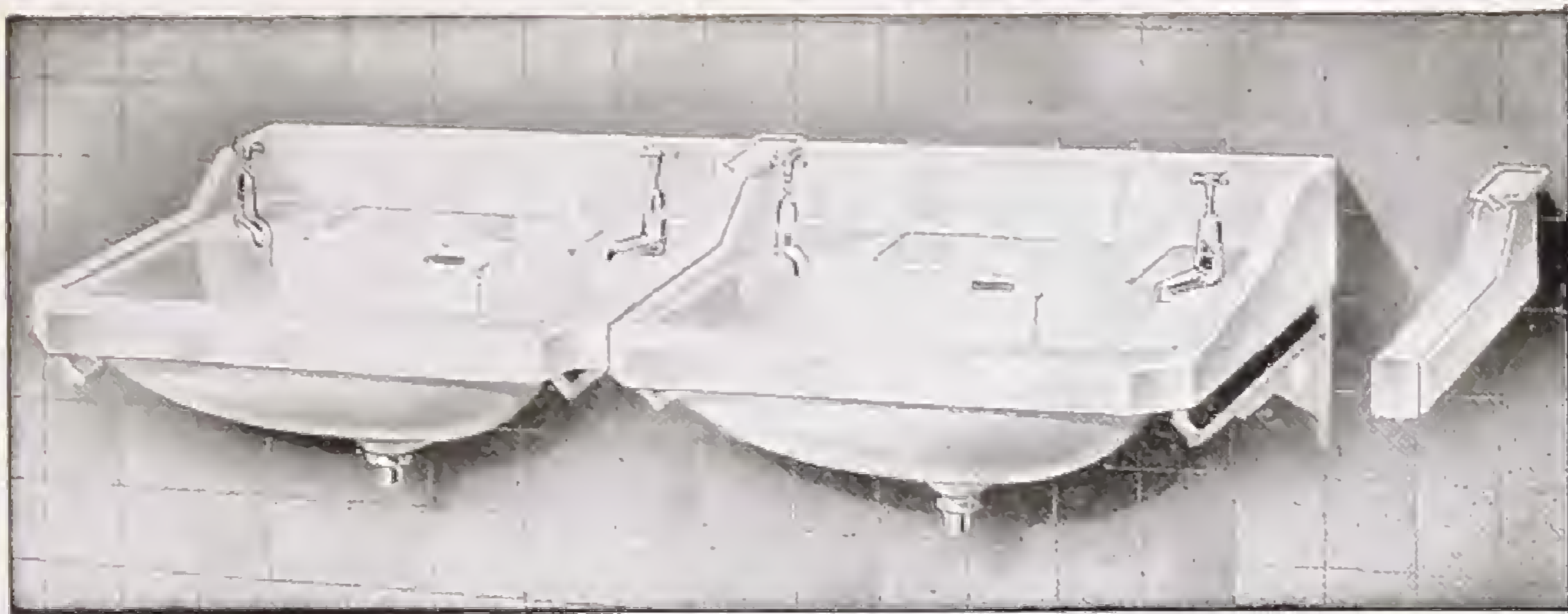

No. B 4481 LAVATORY RANGE

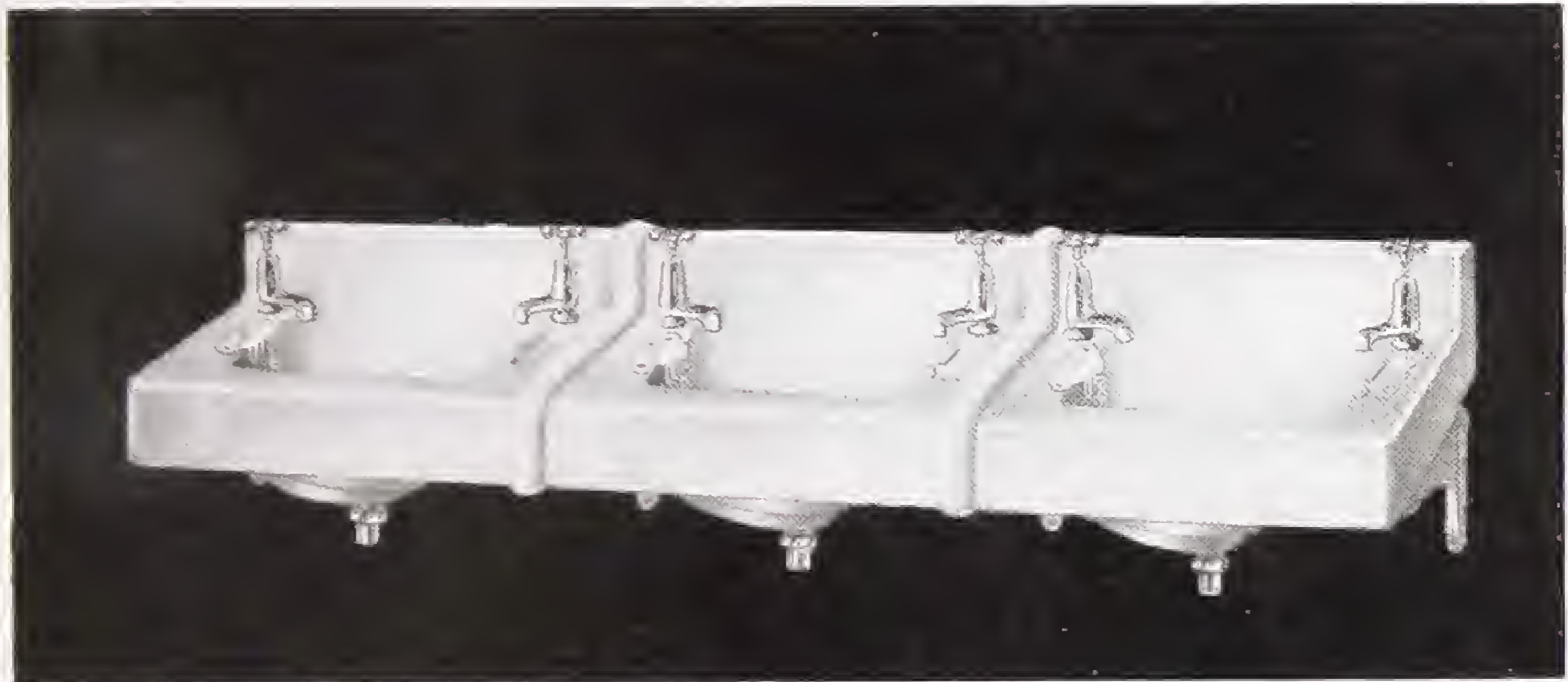

No. B 6314 SCHOOL LAVATORY RANGE

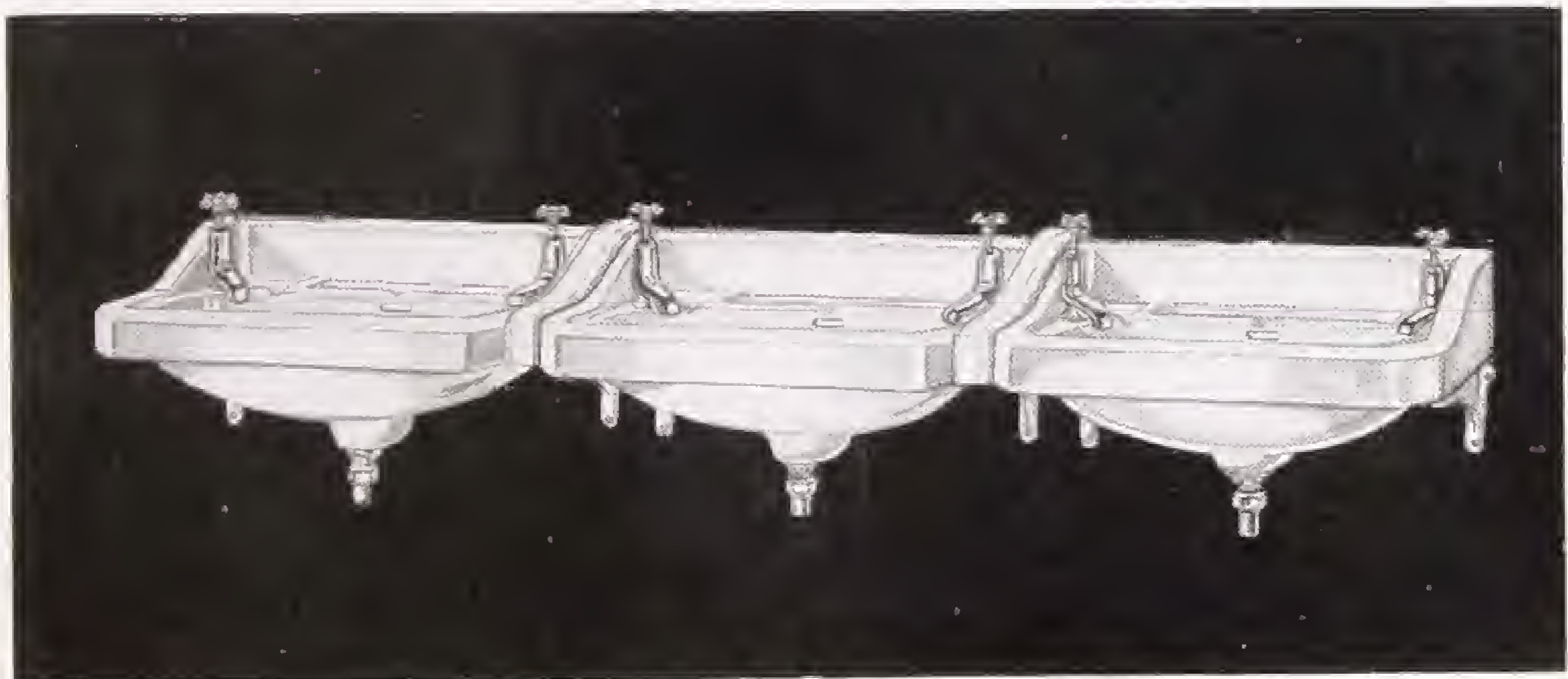

No. B 6315 LAVATORY RANGE

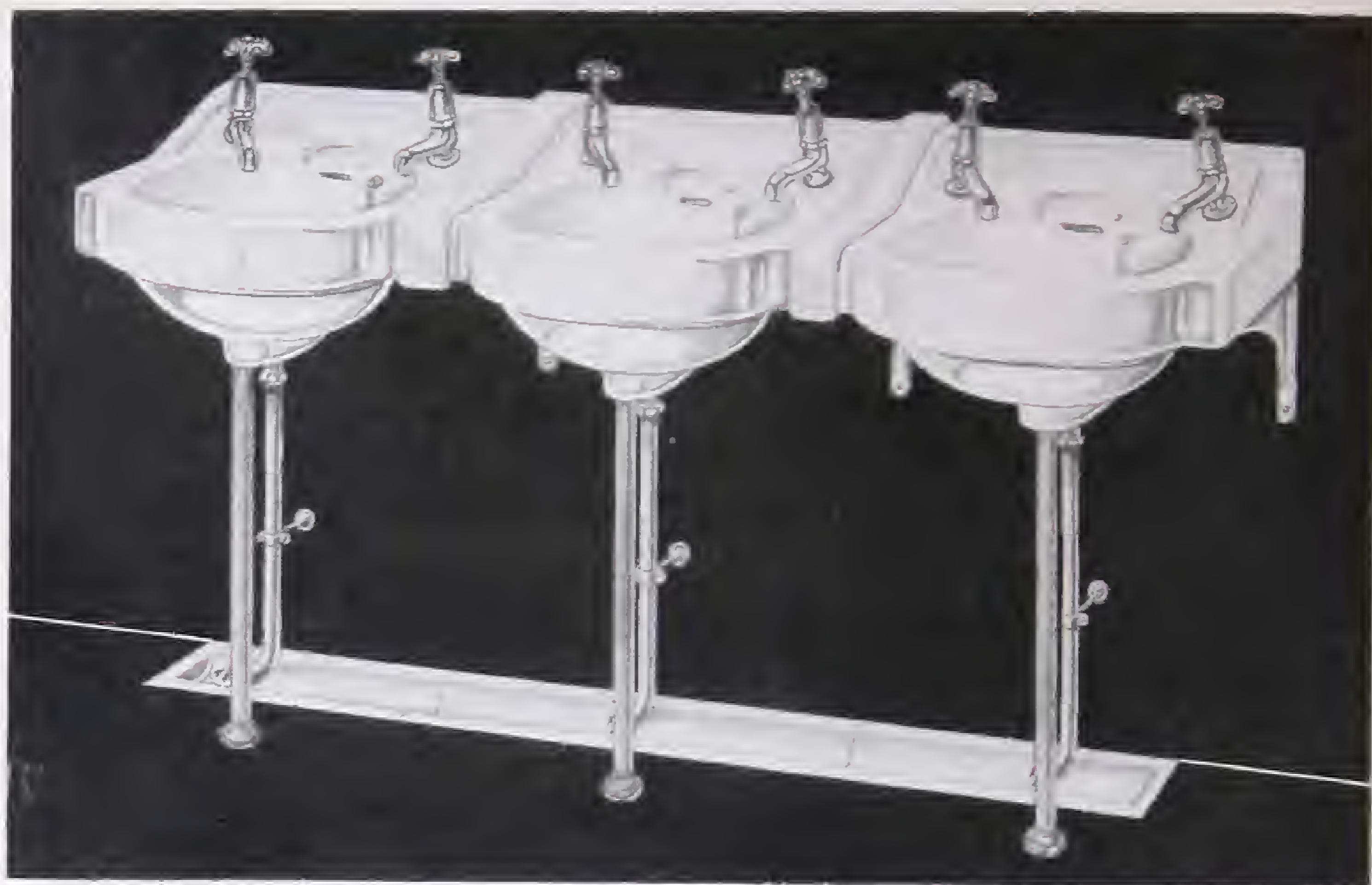

No. B 6313

SCHOOL LAVATORY RANGE

White-glazed Heavy Fireclay

Comprising basins each with soap tray, corner tap holes, sloping back skirting, slot overflow and loose overlap joints ; $\frac{1}{2}$ in. chromium-plated hot and cold pillar taps, $1\frac{1}{4}$ in. waste fittings with plugs, chains, and stays, $1\frac{1}{4}$ in. galvanized steel or copper vertical discharge pipes with wall clips. Painted or white porcelain enamelled brackets with centre pillar legs. Supplied either in range form or with glazed ends for fixing singly.

Overall Size (each basin) :

15 in. X 13 in.

Suitable block floor channel can be supplied if required.



No. B 6008
ISLAND WASHING
FOUNTAIN

Heavy white fireclay basin and pedestal with cover plate. Combined supply and waste fitting with wave, control tap, supply column, outlet grating, and liquid soap containers. Fittings chromium plated.

Diameter of basin	39 in.
Height to rim of basin	32 in.

The supply column is arranged to deliver water in the form of a continuous wave, adjustable by means of a control tap at the top. Outlet grating is formed around the base of supply column. Supply and waste pipe unions whilst concealed in pedestal are readily accessible on removal of cover plate.

Also supplied to order with separate taps instead of wave.

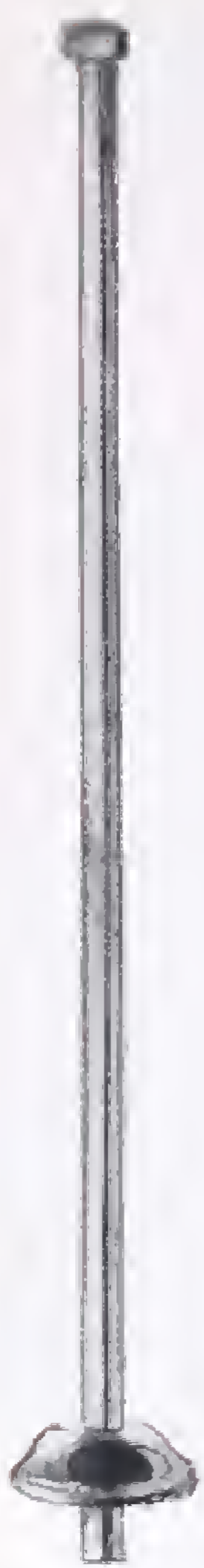

Coupling on outlet to centre of inlet, 12 in.

Wall to centre of outlet, 5 in.



No. B 4485

WALL PATTERN LAVATORY SUPPLY PIPES
With E.C. wheel valves, coupling nuts and wall flanges; inlets having coupling nuts and tails for lead.

Chromium plated.
 $\frac{1}{2}$ -in. bore \times 18 wg.

No. B 4486

As No. B 4485, but without wheel valves.
Also supplied without coupling nuts and tails for lead on inlets

No. B 4483
LAVATORY SUPPLY PIPES

With coupling nuts and floor flanges, Chromium plated.

$\frac{1}{2}$ -in. bore \times 30-in. \times 18 wg.
Extra if with coupling nuts and bent tails for lead on inlets.

No. B 4484
LAVATORY SUPPLY PIPES.

With $\frac{1}{2}$ -in. E.C. wheel valves, coupling nuts and floor flanges; inlets having coupling nuts and bent tails for lead. Chromium plated.

$\frac{1}{2}$ -in. bore \times 30-in. \times 18 wg.
Also supplied without coupling nuts and bent tails for lead on inlets

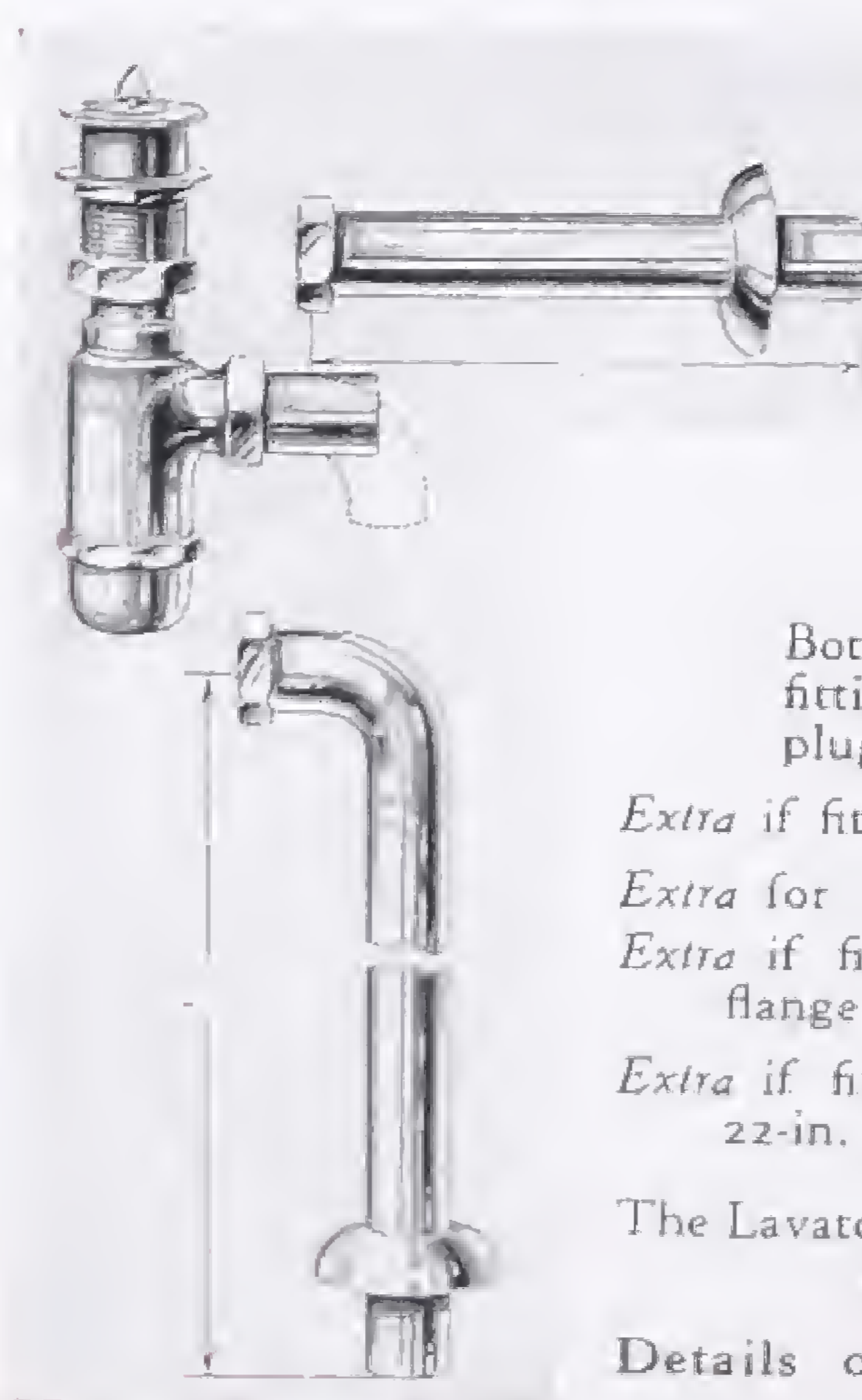

No. B 4487
CHROMIUM-PLATED BRASS BOTTLE TRAP

With $1\frac{1}{2}$ -in. seal, inlet screwed $1\frac{1}{4}$ -in. female gas, coupling nut and straight tail for lead on outlet

No. B 4488

Bottle trap, as above, but complete with waste fitting, having back nut, washer and vulcanite plug. Waste screwed direct into trap

Extra if fitted with coupling nut between trap and waste

Extra for bent tailpiece

Extra if fitted with 10-in. outlet pipe to wall and wall flange

Extra if fitted with outlet pipe to floor and floor flange. 22-in. centre to end

The Lavatories illustrated on previous pages are *not* supplied with the above bottle trap as standard.

Details of further types of bottle traps will be found on page 144.



No. B 1269
CAST-IRON STAND

Plain-painted; with front towel rail.
Sizes: 22 in. × 16 in., 25 in. × 18 in.

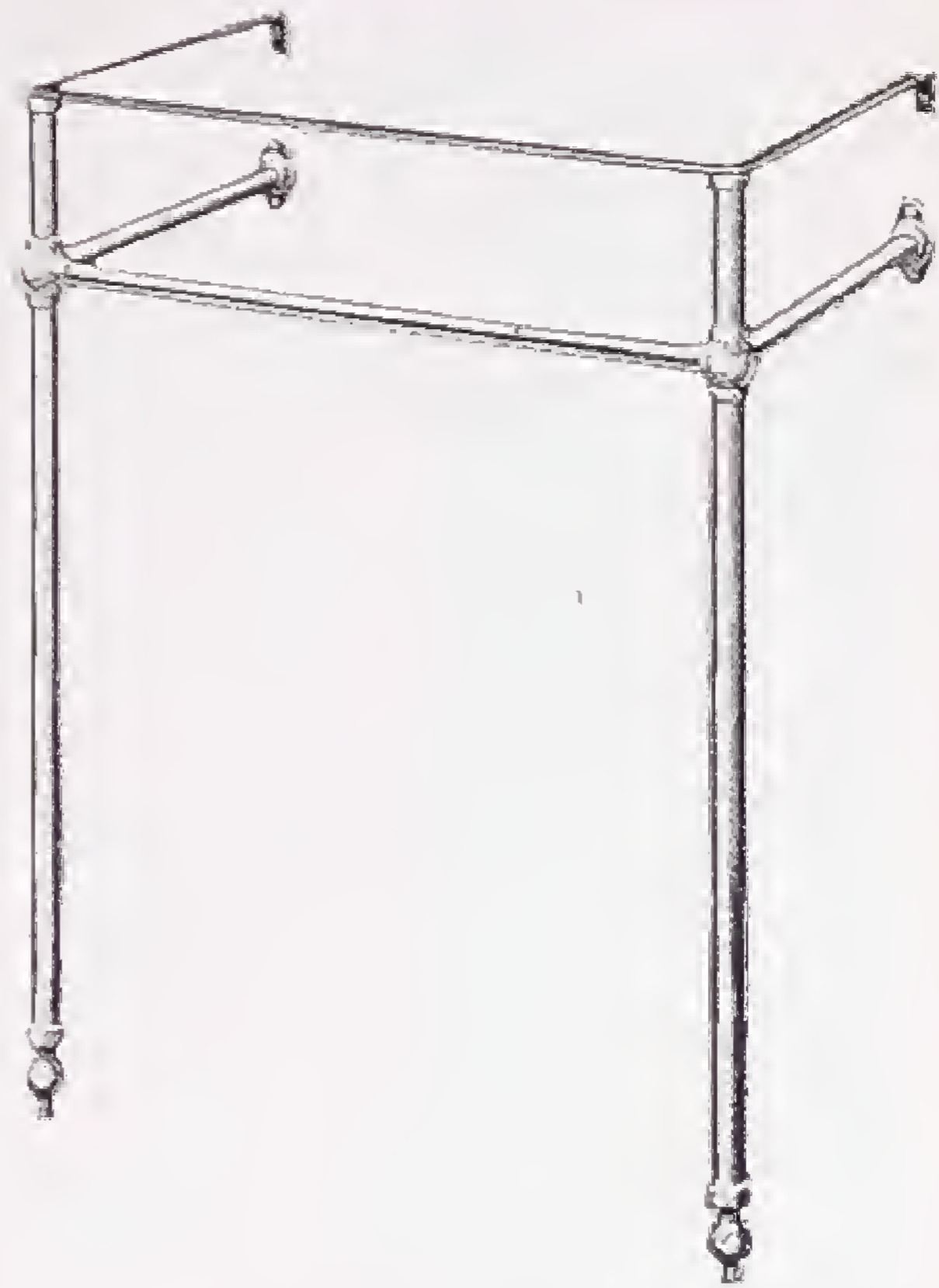

No B 1266
BRASS STAND

Chromium-plated
 $\frac{1}{2}$ in. rails. $\frac{3}{4}$ -in. legs to floor
To suit all standard basins.

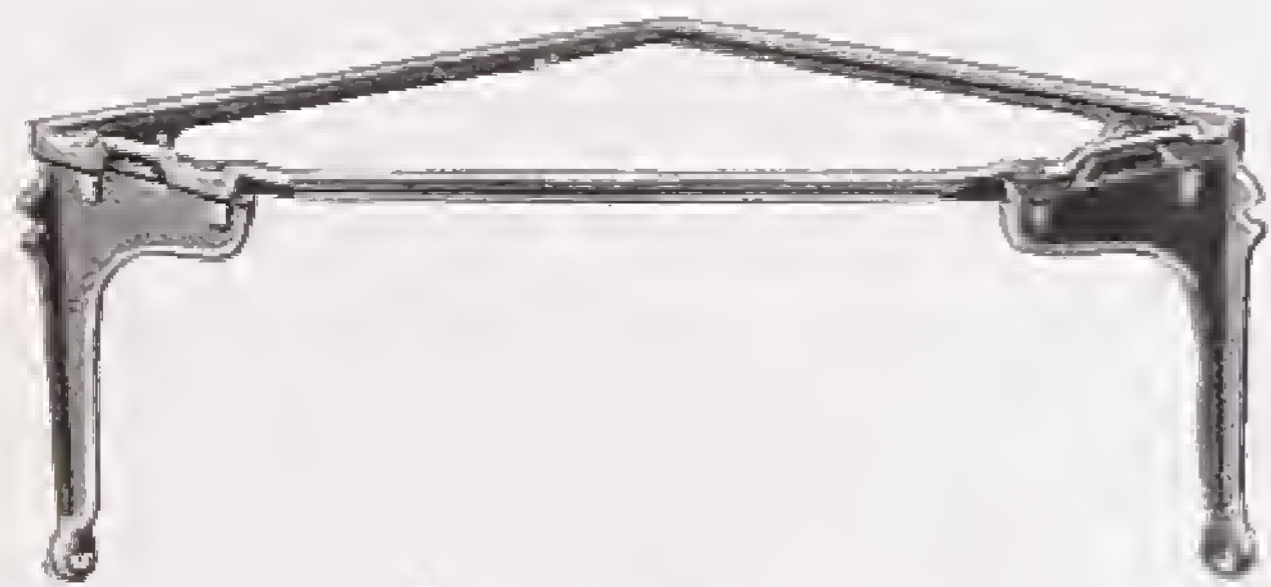

No. B 1262
CAST-IRON FRAME AND BRACKETS

Plain painted; for angular Basins.
24 × 18 in. 27 × 20 in. 30 × 22 in.

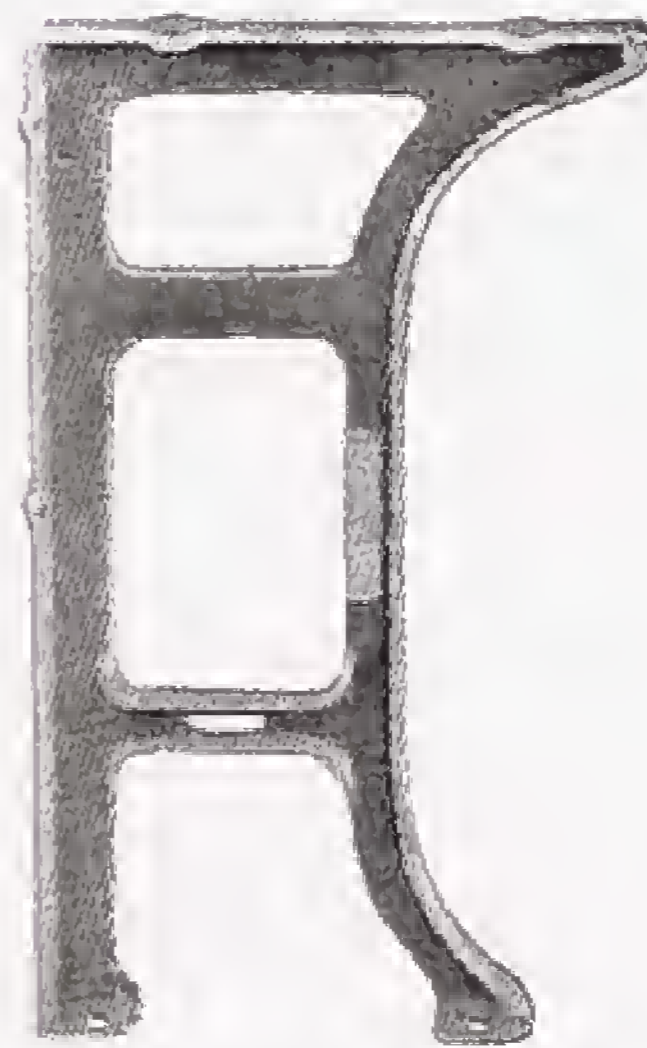

No. B 1250
STANDARD Beanco Pattern
Plain-painted cast-iron.
Height, 27 in. Top, 16 in.
Bottom, 13 $\frac{1}{4}$ in.

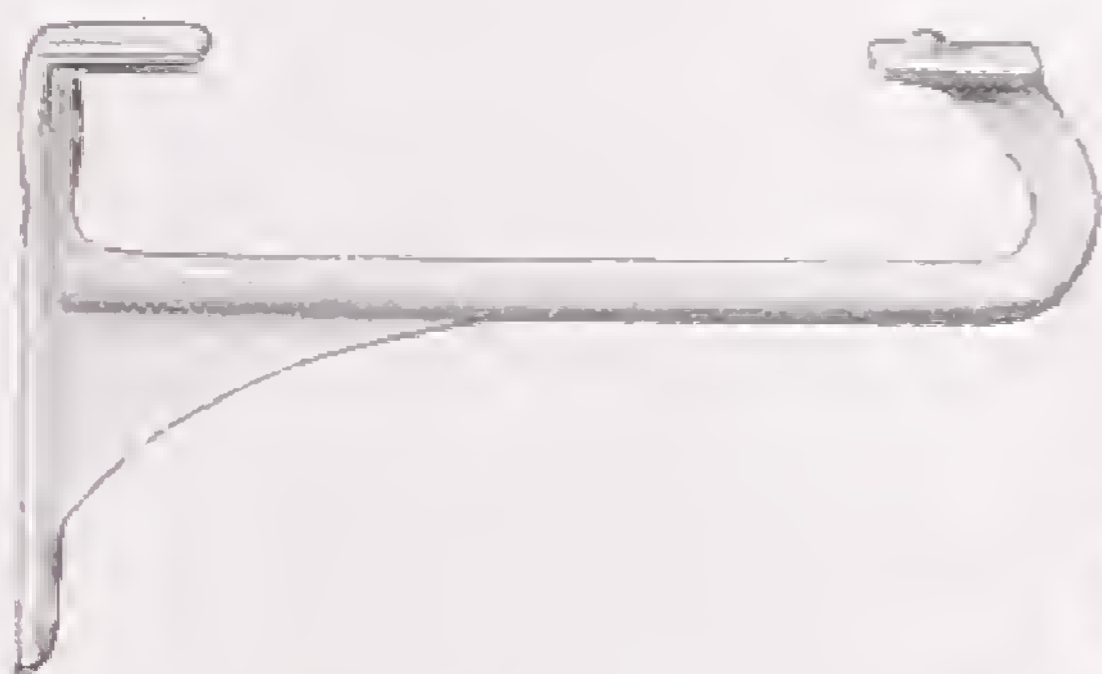

No. B 1264
CAST-IRON TOWEL RAIL BRACKET

To suit all Standard Lavatories.
White porcelain-enamelled.
Coloured porcelain-enamelled
Plain painted.



No. B 1263
CAST-IRON CANTILEVER BRACKET

$4\frac{1}{2}$ -in. end for building into wall, plain-painted.
14 15 16 17 18-in. projection

BAXENDALE & CO. LTD.

No. B 591 THE VEL-SPA WATER SOFTENER



Comprising all-welded steel cylinder tested to 300 lbs. hydraulic pressure, finished externally in green enamel, but other colours can be supplied on request. Rust-proofed inside and out by the hot galvanizing process, and all fittings, filters, caps, etc., are made of bronze.

The New Single Control Valve operates all controls with one movement.

Model	Output on 16° Galls.	Cylinder Size	Salt per Regeneration lbs.
L 4 (S)	460	31½ × 9½	5
L 5 (S)	600	38 × 9½	6
L 6 (S)	750	42 × 9½	7
L 7 (S)	1000	44 × 12	8
L 8 (S)	1600	53 × 12	13
L 9 (S)	2200	52 × 15	20
L 10 (S)	3650	56 × 18	30

To Select a Suitable Model

The use of Washing Machines, extra basins, taps, etc., in the modern home has increased the use of water and it now stands at 35 gallons per person per day throughout the country generally as a maximum consumption.

Assuming a district water supply to be 16° hard, a family of four people would use some 100 gallons per day, and a Model L7 would cover their needs for one week between regeneration. A model L3 would require regeneration every four days or so under the circumstances.

The larger the Model that can be purchased originally, the more economy in time and depreciation is ensured, and a generous reserve is provided for visitors.

The life of the bed is normally 8 to 10 years, and after this period is very simply renewed, bringing output back to normal.

MILLER STREET · MANCHESTER

No. B 2164

PEDESTAL DRINKING FOUNTAIN

Cast-iron with non-concussive push tap and sloping jet, control stop-cock and hand access door. Fittings polished or chromium-plated.

Bowl can be supplied plain-painted, galvanized, or white porcelain-enamelled, and the pedestal can also be supplied in any of these finishes, i.e., W.P.E. bowl, plain-painted pedestal, etc., etc.

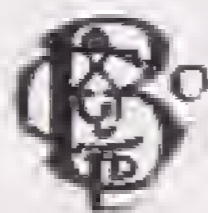

No. B 2163

BRACKET DRINKING FOUNTAIN

Cast-iron white porcelain-enamelled with non-concussive push tap, waste grating and coupling for $\frac{1}{2}$ in. lead pipe; brasswork either polished or chromium-plated. Projection 14 in., width 8 in.

Note.—Height of jet can be regulated and the fountain is so arranged that the water cannot fall back on the jet nozzle.

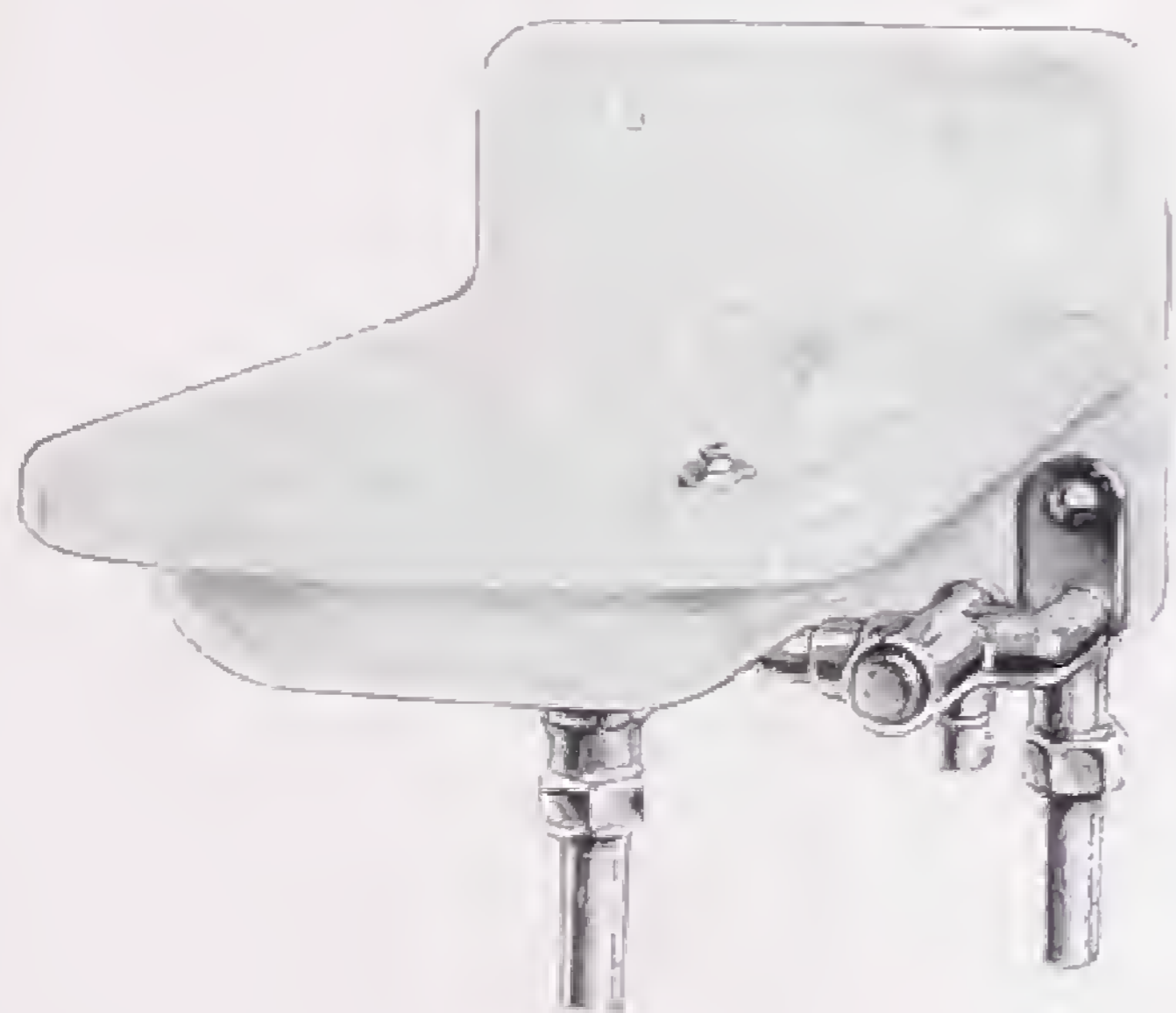

No. B 6385

A.B.M. PURAQUA DRINKING FOUNTAIN

Chromium-plated brass with 5 in. diameter catchment bowl, single stream jet with anti-splash device and double spring-operated universal lever valve with volume regulating screw. Inlet $\frac{1}{2}$ in., outlet $\frac{3}{4}$ in. Can also be supplied with raised nozzle and lip guard which lifts the level of the fresh water supply above the top of the bowl. When ordering, please state which type is required.

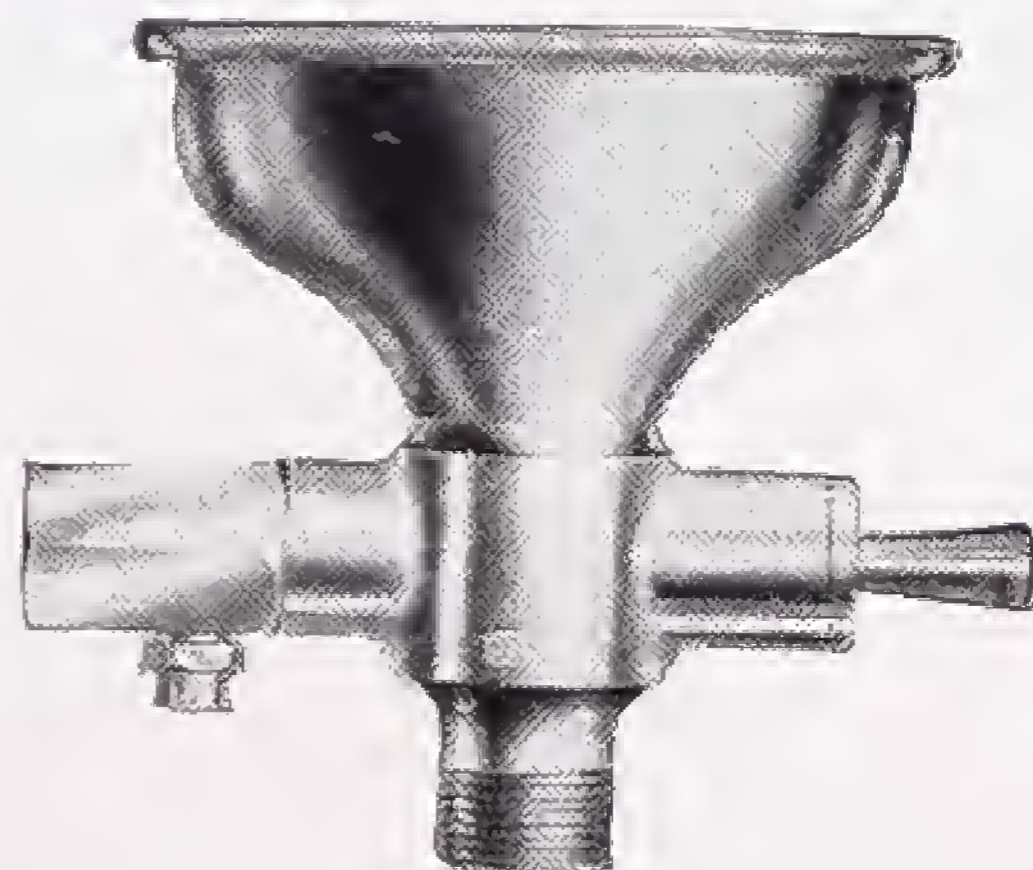



No. B 5019. TOWEL AIRER
Chromium-plated round tubes.
Size: Height 36 in.; Length 36 in.
1 in. Tubes or 1½ in. Tubes

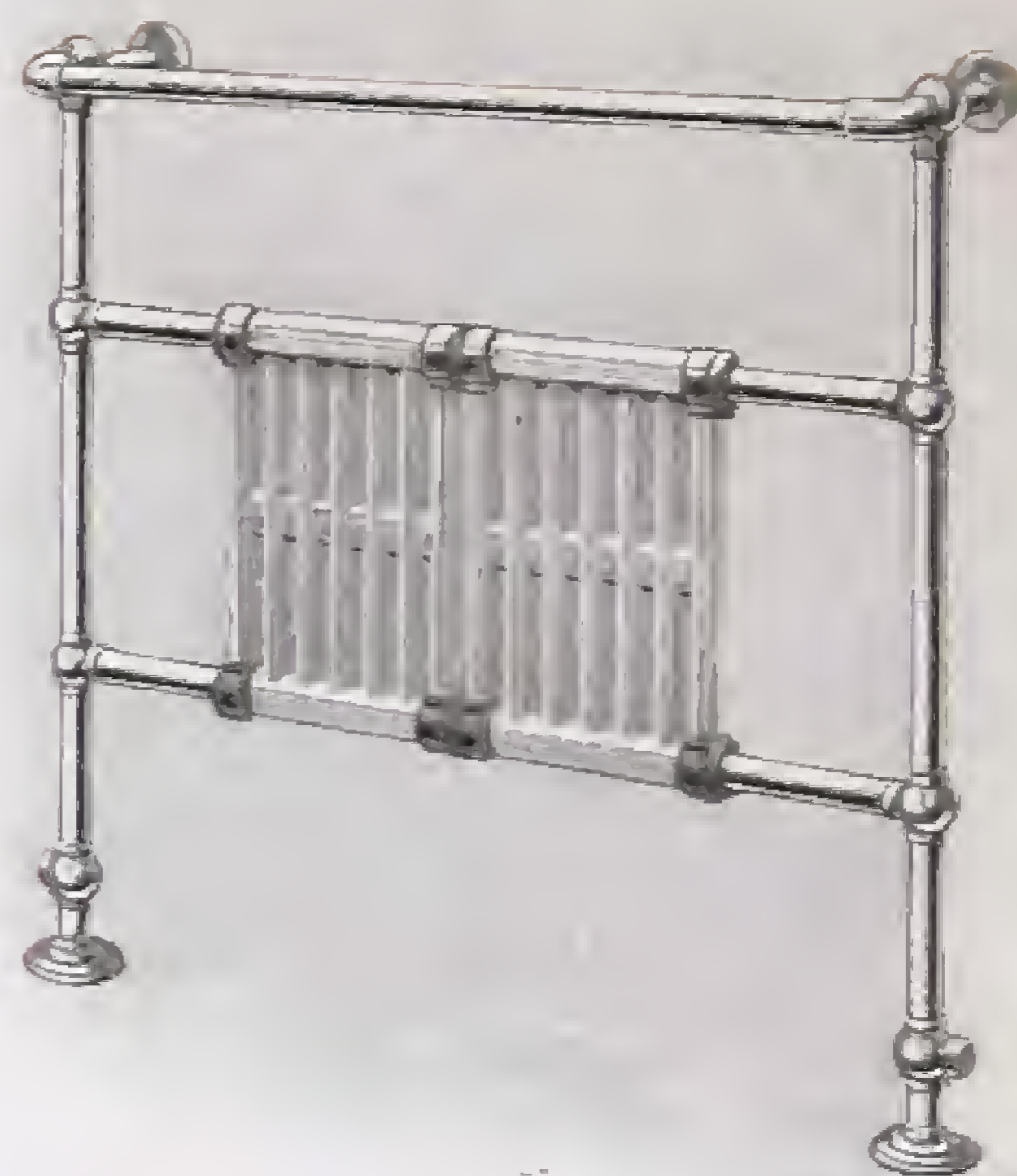

No. B. 5021. TOWEL AIRER
With Radiator.
Chromium-plated 1½ in. round tubes
with wall supports.
Radiator silver sprayed.
Sections can be supplied. Bower-
barffed if required.
Size: Height 36 in.; Length 36 in.



No. B 4093. TOWEL AIRER
Chromium-plated round tubes with
wall supports.
Size: Height 36 in.; Length 36 in.
1 in. Tubes or 1½ in. Tubes.



No. B 4107. TOWEL AIRER
Chromium-plated hexagonal tubes.
Double top rail.
Size: Height 36 in.; Length 36 in.
1½ in. Tubes.

No. B 4094, as above but with
single top rail.

We can also supply Towel Airers 30 in. or 24 in. long. Details on request.



No. B 5020
TOWEL AIRER

Chromium-plated round tubes.
Double top rail.

Size: Height 36 in.; Length 36 in.
1 in. or 1½ in. Tubes

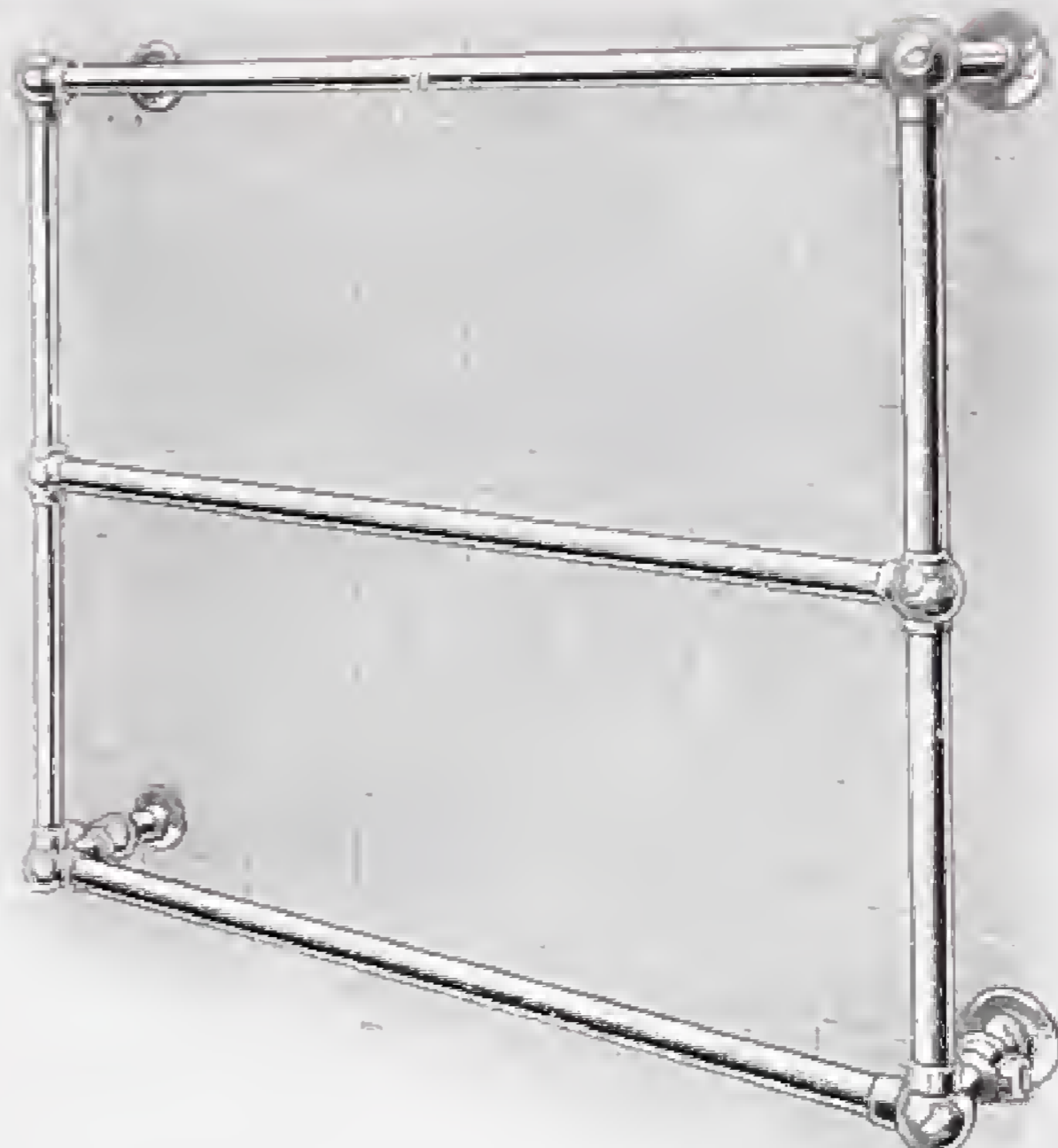

No. B 4092
TOWEL AIRER

Chromium-plated round tubes
for wall fixing.

Size: Height 30 in.; Length 36 in.
1 in. or 1½ in. Tubes

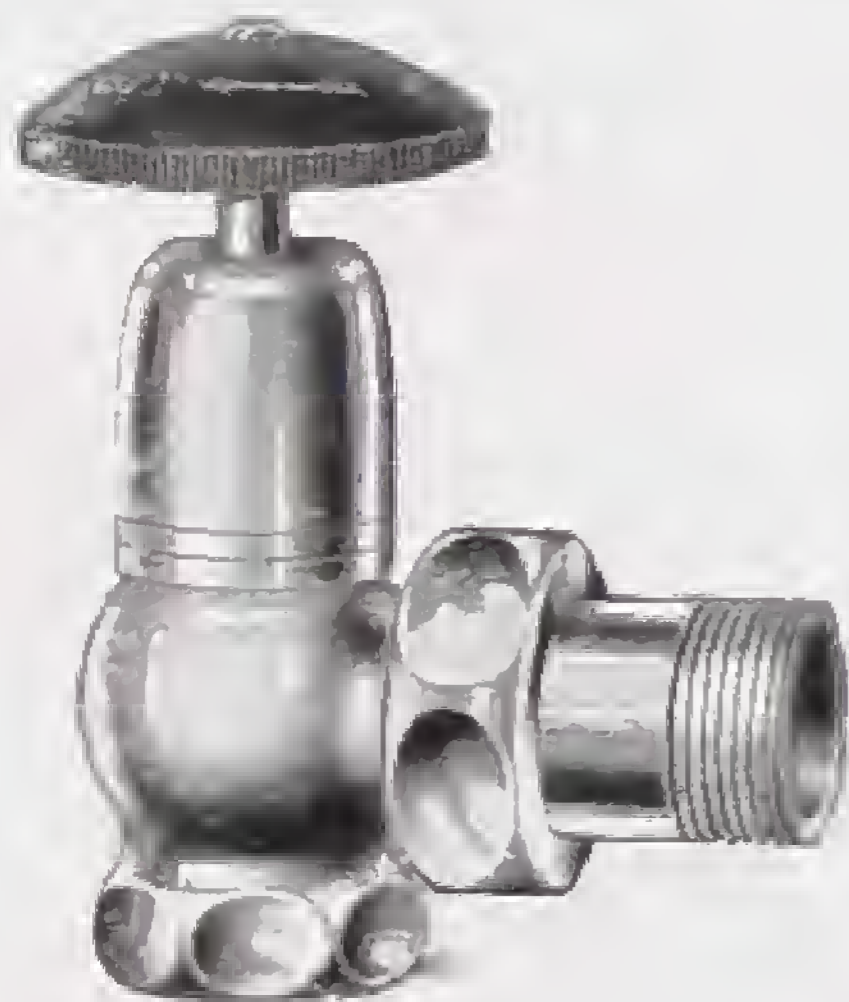

No. B 4116



No. B 4119

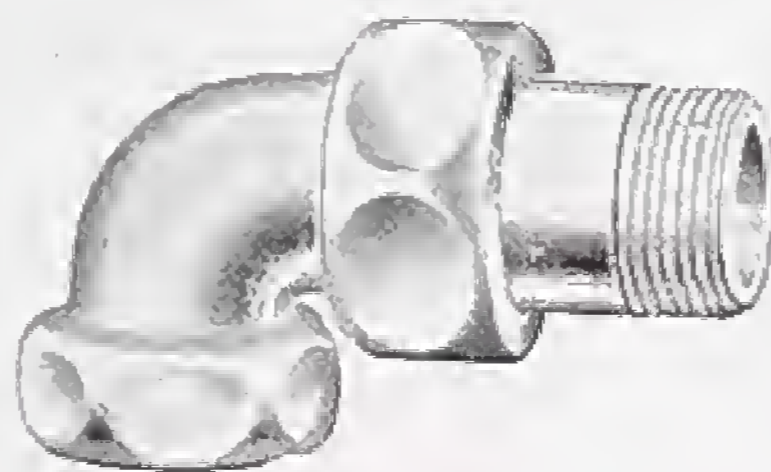

No. B 4118

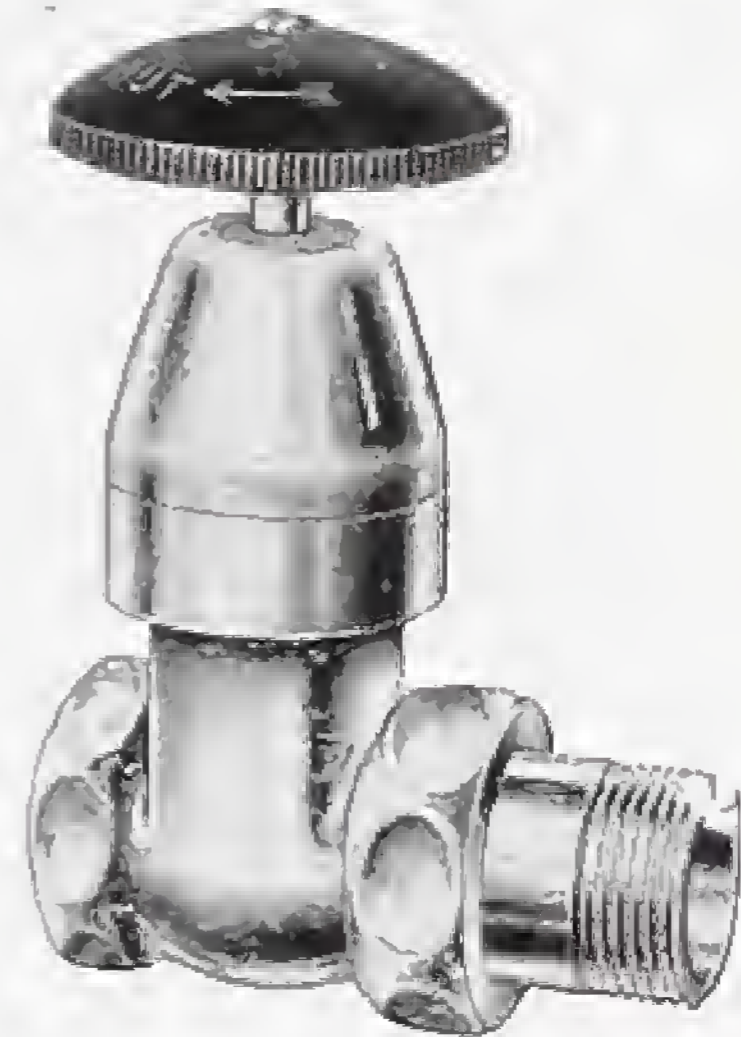

No. B 4117

CHROMIUM-PLATED SMOOTH-BODY VALVES AND UNIONS

For Towel Airers. ¾ in. size.



No. B 4125

SPLIT FLOOR FLANGES

To fit round the pipe connections to Towel Airers.

Diameter, 2½ in.

Chromium-plated.



No. B 4120

WALL STAYS

For Towel Airers.

To give distances up to 8 in. from wall to centre of tube.

When ordering, state distance required.

RECESSED FITTINGS

WHITE OR COLOURED

For Building in.

Commercial Quality Glazed Earthenware



No. B 4490
Tongue-Lipped Grip
Soap Holder 6×6-in.

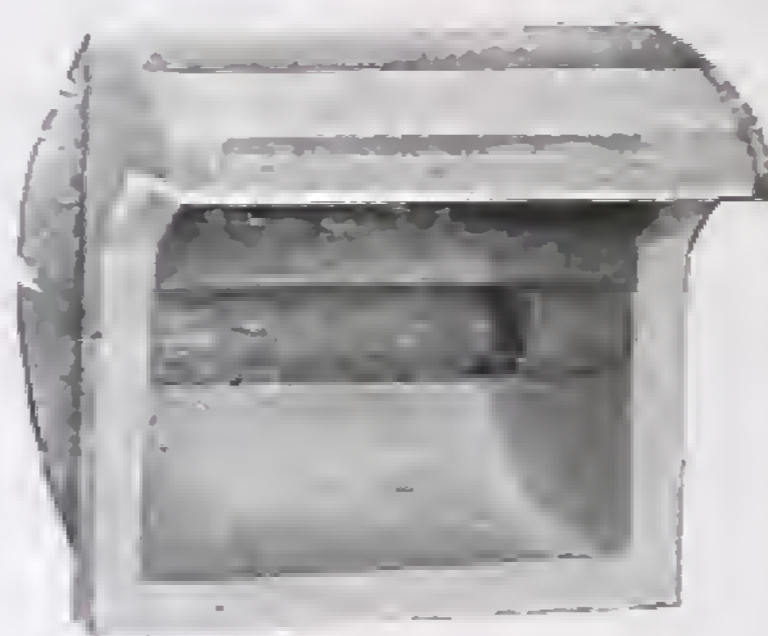

No. B 4491
Hooded Toilet-Paper
Holder With Wooden
Spring Roller. 6×6-in.



No. B 4492
Tongue-Lipped
Soap Holder 6×6-in.

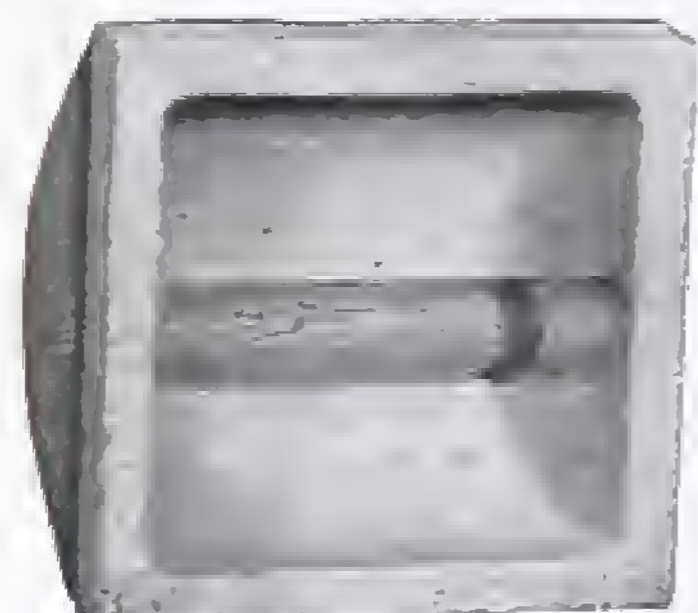

No. B 4493
Plain Toilet-Paper
Holder
Wooden Spring Roller.
6×6-in.



No. B 4494
Tongue-Lipped Deep Sponge
and Soap Holder 12×6-in.



No. B 4495
Plain-Lipped
Soap Holder
6×6-in.



No. B 4496
Tongue-Lipped Sponge and
Soap Holder
Without Partition. 12×6-in.

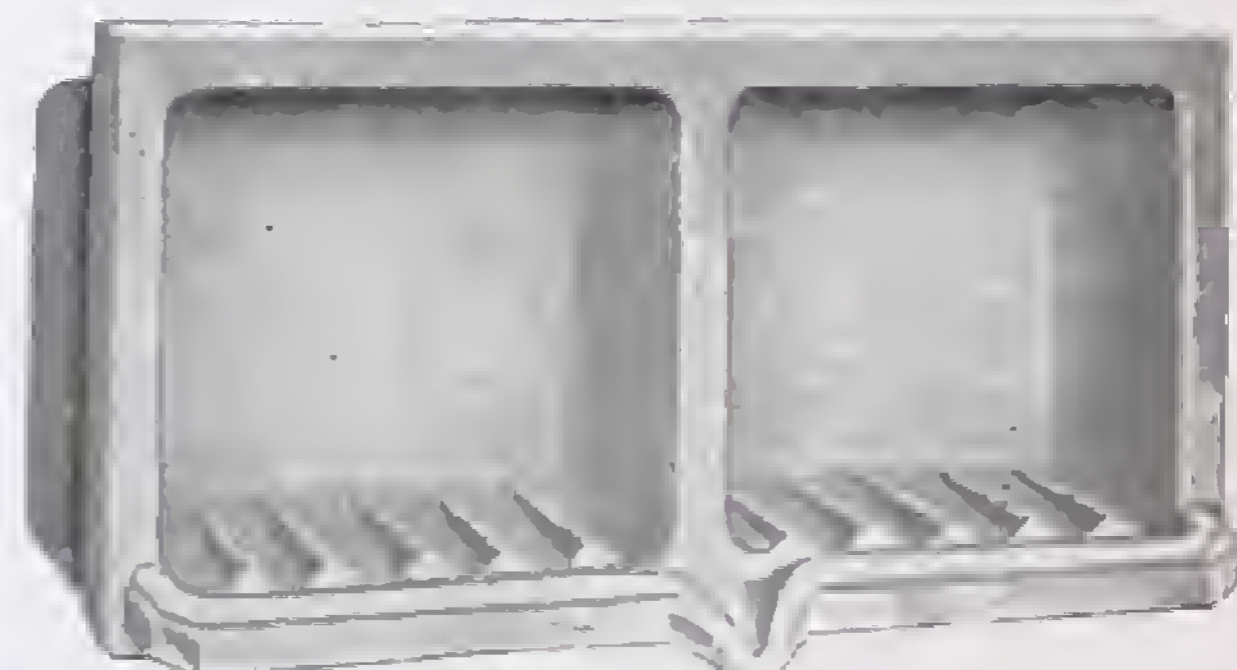

No. B 4497
Tongue-Lipped Sponge and
Soap Holder 12×6-in.



No. B 4498
Tongue-Lipped Grip Sponge
and Soap Holder
Without Partition. 12×6-in.



No. B 4499
Tongue-Lipped Grip Sponge and
Soap Holder 12×6-in.

RECESSED FITTINGS

WHITE OR COLOURED

For Building in

Commercial Quality Glazed Earthenware



No. B 4500
Plain-Lipped Soap
Holder 6×3 in.



No. B 4501
Tongue-Lipped Soap
Holder 6×3 in.

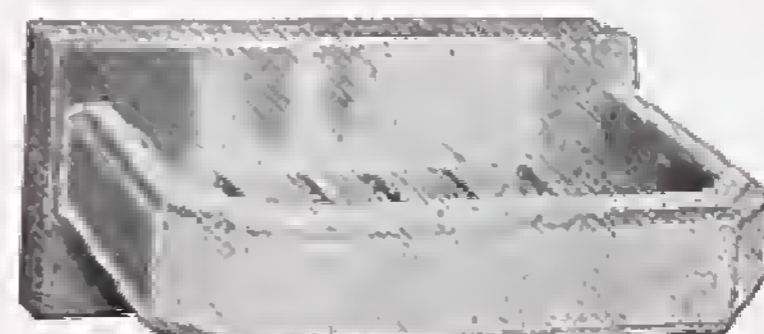

No. B 4502
Plain Soap Dish
6×3 in.

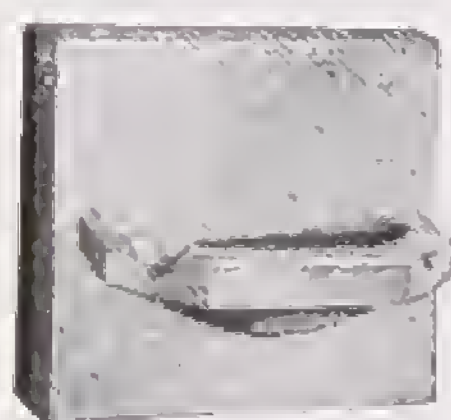

No. B 4503
Ashtray 4×4 in.

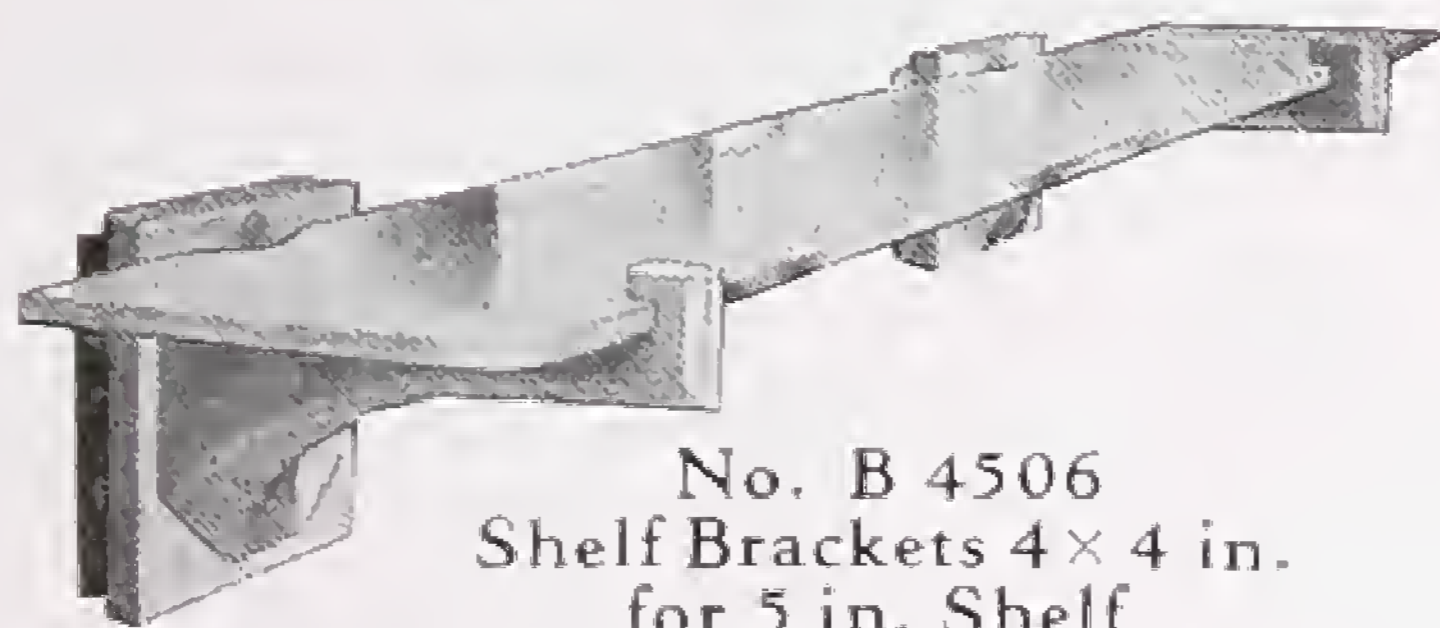

No. B 4506
Shelf Brackets 4×4 in.
for 5 in. Shelf



No. B 4505
Coat Hook
4×4 in.



No. B 4507
Tongued Soap Dish
6×3 in.

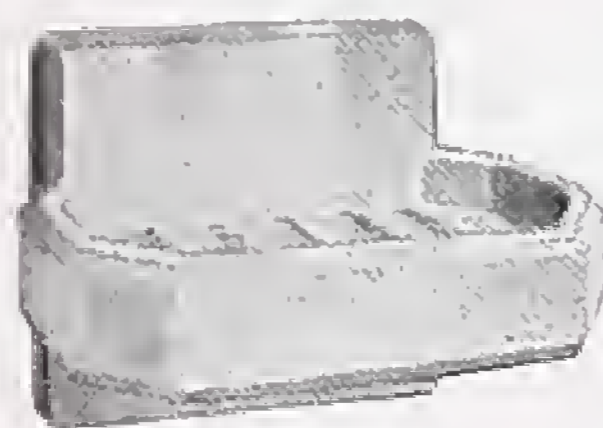

No. B 4504
Soap Dish 4×4 in.

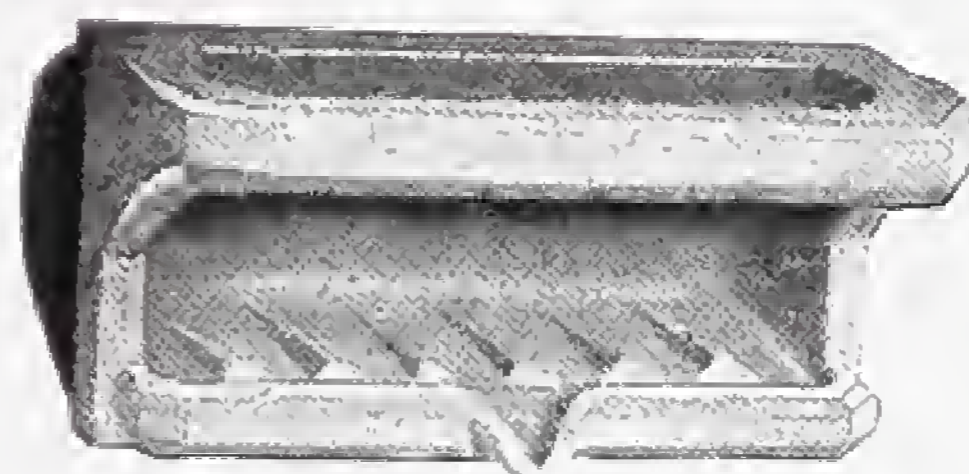

No. B 4508
Tongue-Lipped Grip Soap
Holder 8×4 in.

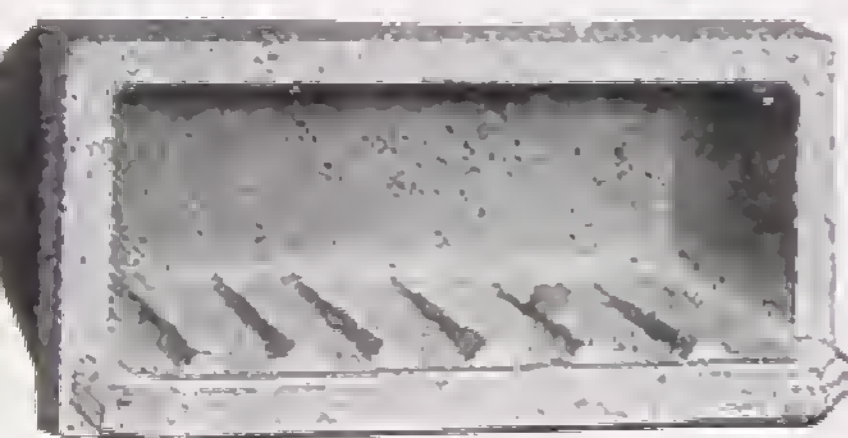

No. B 4510
Plain-Lipped Soap
Holder 8×4 in.

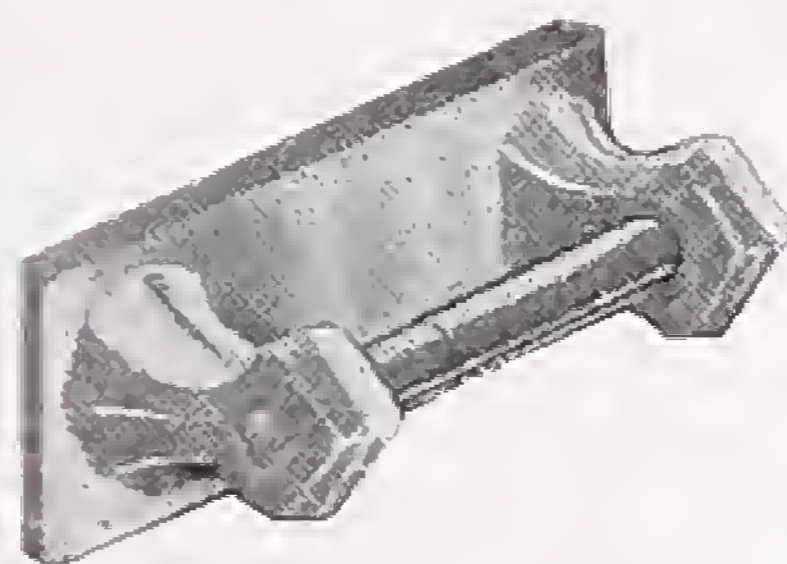

No. B 4512
Toilet-Paper Holder
9×3 in.
With Spring Wooden
Roller

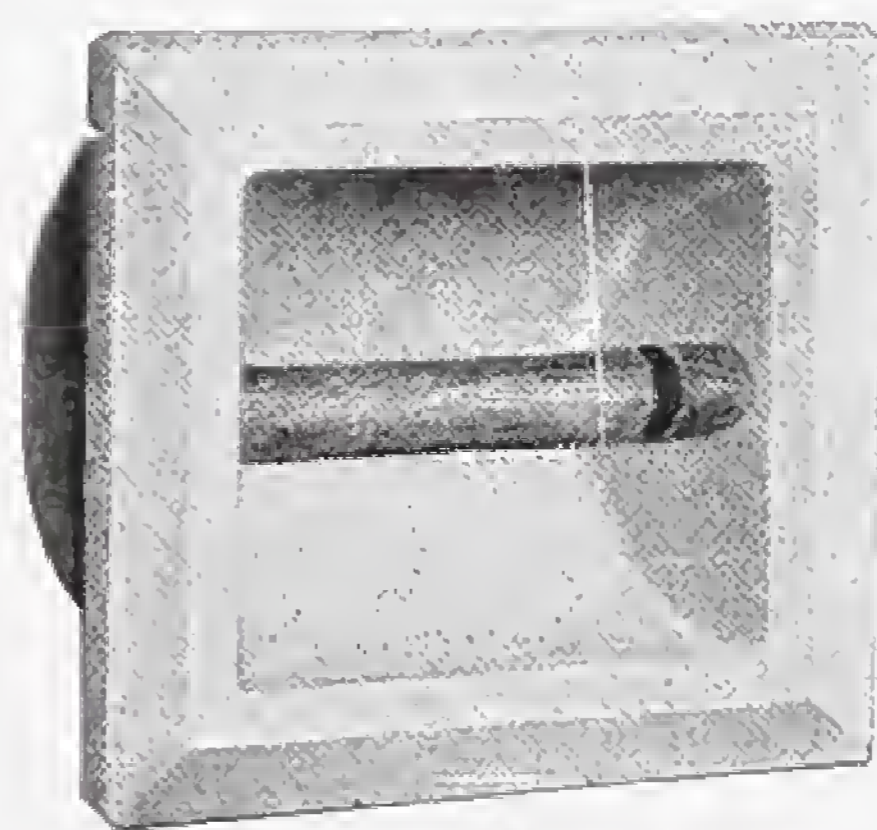

No. B 4509 Toilet-Paper
Holder 8×8 in.

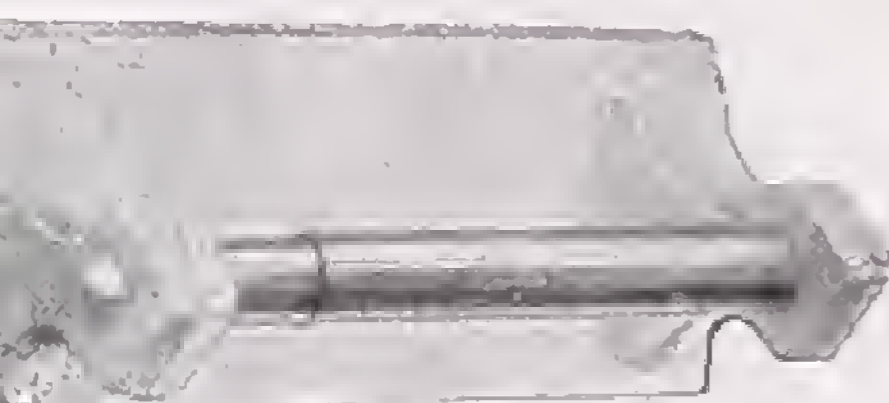

No. B 4513
Toilet-Paper Holder
8×4 in.
With Wooden Roller



No. B 4514
Tongue-Lipped Soap
Holder 8×4 in.

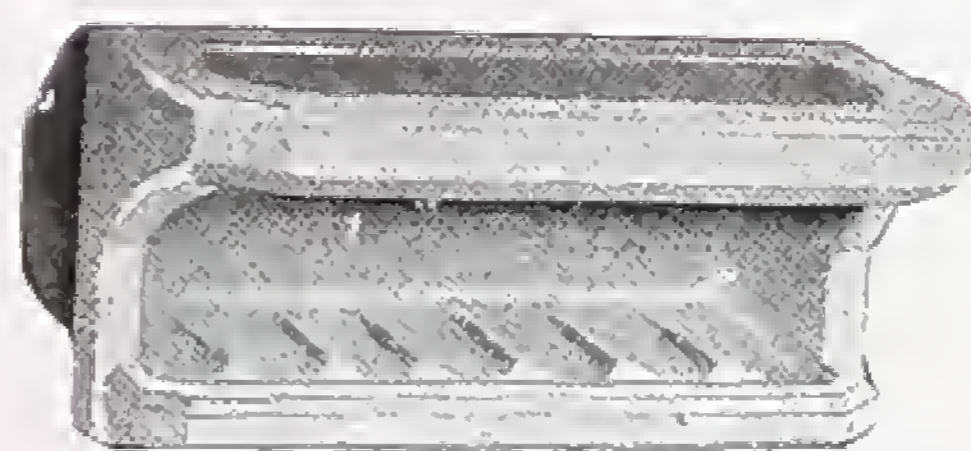

No. B 4511
Plain-Lipped Grip
Soap Holder 8×4 in.

CHROMIUM-PLATED BATHROOM ACCESSORIES



No. B 4073
ROBE HOOK



No. B 4071 **SHELF and BRACKETS**
Plate Glass Shelf 5 in. wide. Lengths 18, 21, 24 in.



No. B 4069
**TUMBLER
HOLDER**



No. B 4072 **SHELF and BRACKETS**
With Guard Rail. Sizes as above.

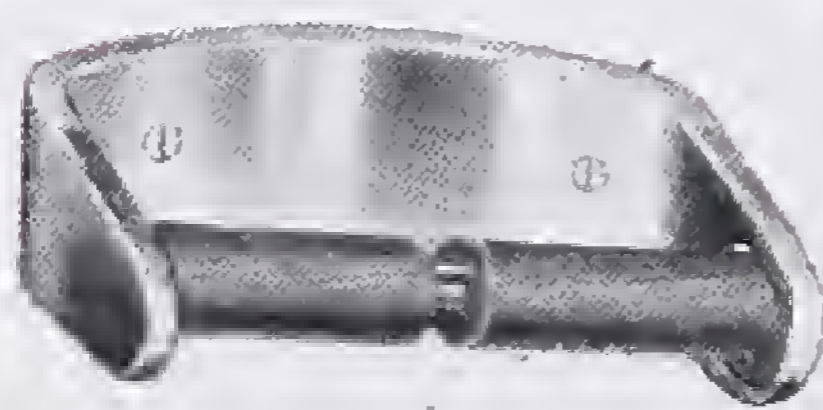

No. B 4077
**"THIEF-PROOF"
TOILET PAPER
HOLDER**
Paper cannot be removed
until roll is finished.

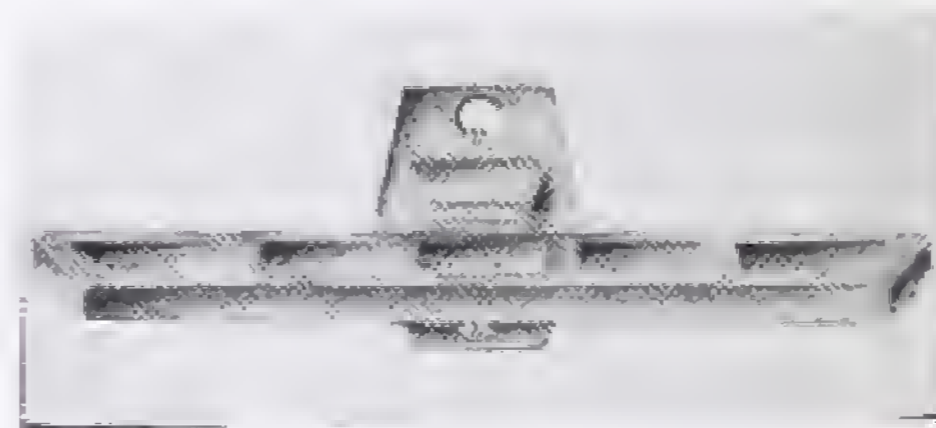

No. B 4070
**TOOTH-BRUSH
HOLDER**

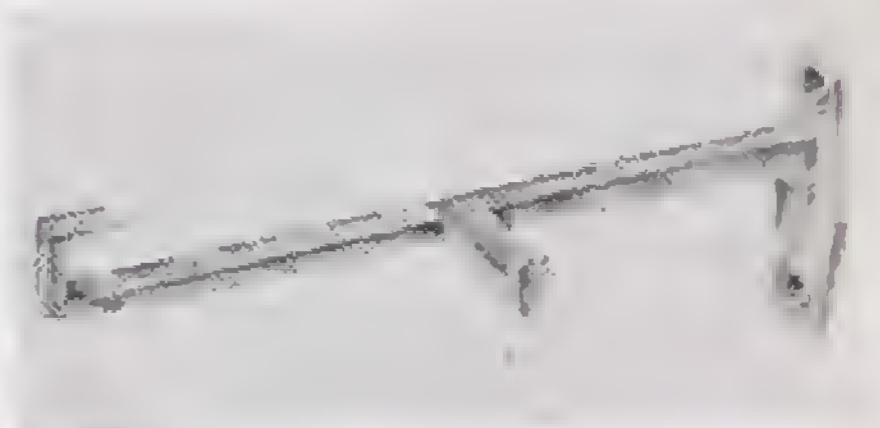

No. B 4074
SHELF BRACKET
With side lug to prevent
shelf slipping.

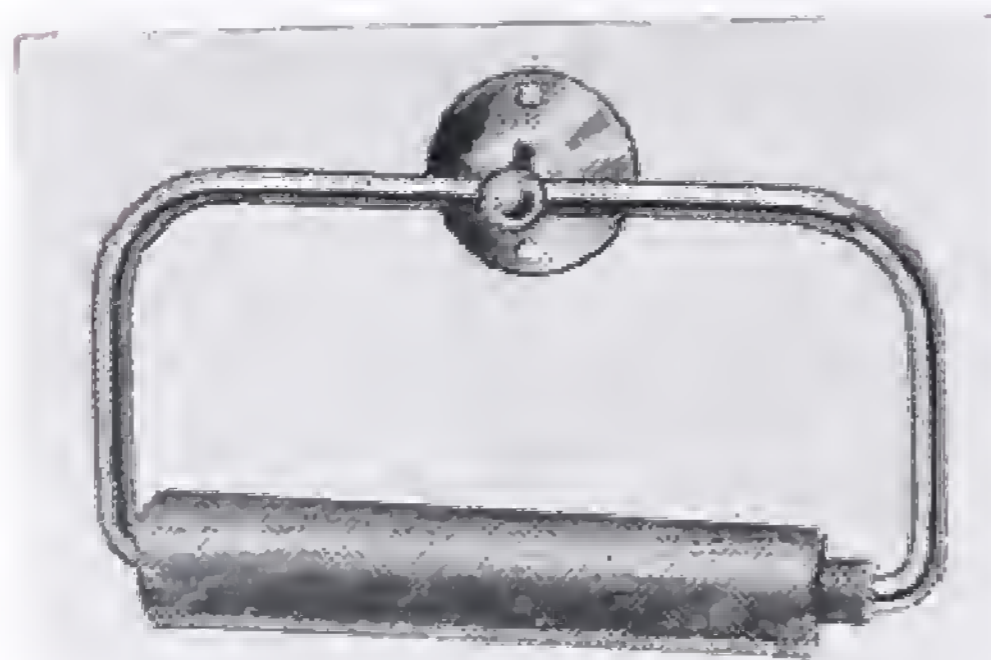

No. B 4075
TOILET PAPER HOLDER
 $\frac{1}{2}$ in. dia. Bracket and Spring Roller.

*All fittings
are sent out
with suitable
fixing screws*

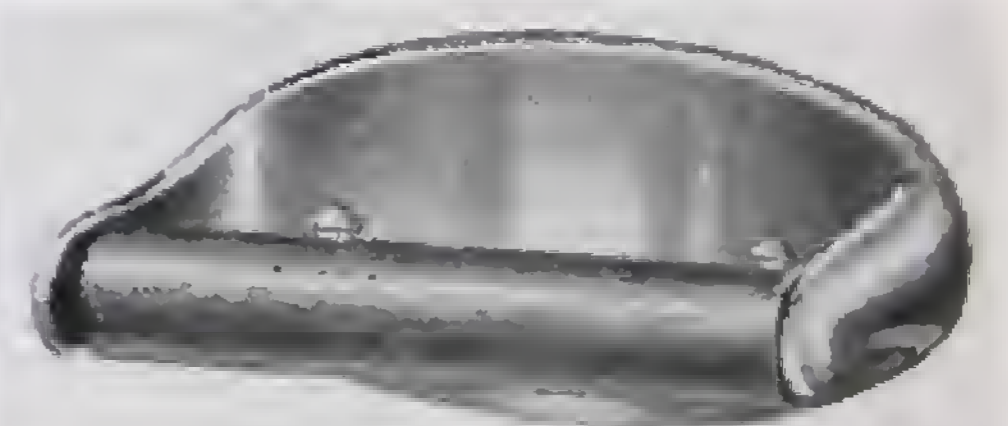

No. B 4076
TOILET PAPER HOLDER
Cast Bracket and Spring Roller.

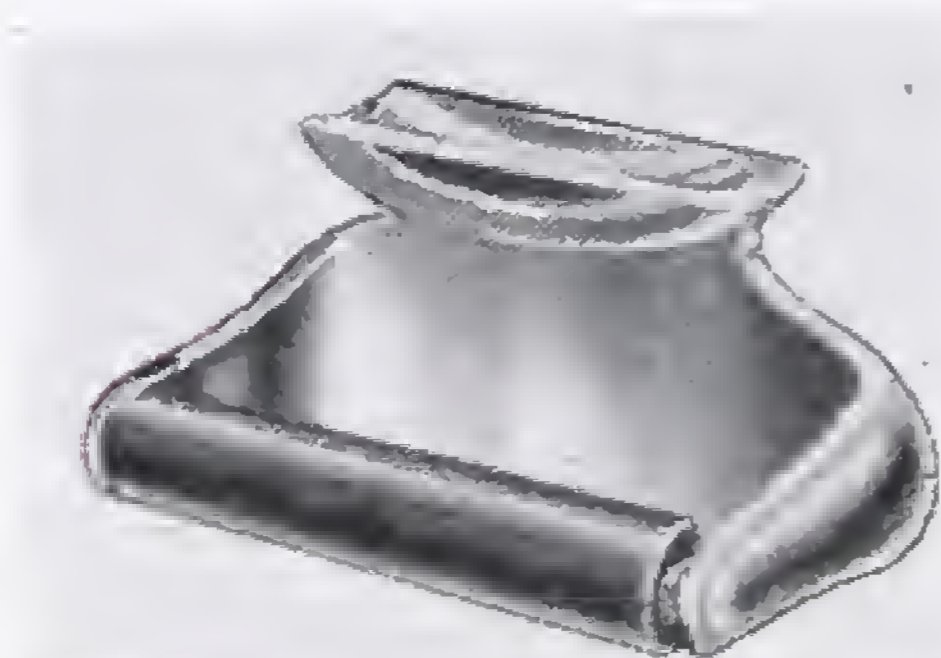

No. B 4078
**TOILET PAPER
HOLDER**
With Ashtray and
Spring Roller.

No. B 4079
**TOILET PACK
HOLDER**
Black, Green, or Ivory
Plastic.



CHROMIUM-PLATED TOWEL AND GRAB RAILS

No. B 4063

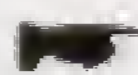

BENT TUBE TOWEL RAIL

With wall plates, $\frac{1}{2}$ in. dia., 3 in. projection. Lengths 18, 24, 30, 36 in.



No. B 4064

SWING WALL TOWEL RAIL

Round pattern, 15 in. projection. $\frac{1}{2}$ in. dia. rails with spring bearings. Single Rail, Double Rail (illus.) Triple Rail.

No. B 4065



TOWEL RAIL

With end posts and 1 in. dia. rail. Lengths 18, 24, 30, 36 in.



No. B 4066

SWING WALL TOWEL RAIL

Square pattern, 15 in. projection with $\frac{1}{2}$ in. square rails and spring bearings. Single Rail, Double Rail, Triple Rail (illus.)

No. B 4067

BATH GRAB RAIL

Length 9 in. over tube \times 1 in. dia. Projection 2 $\frac{1}{2}$ in.

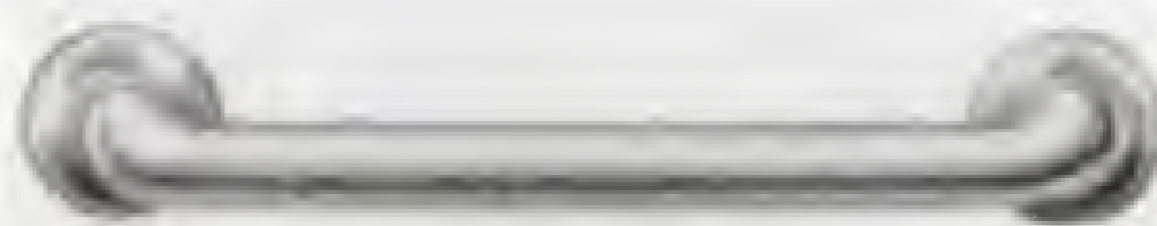

No. B 4068 ROLLER TOWEL RAIL

Heavy black synthetic tube roller 20 in. long \times 2 in. dia. Can also be supplied with lock and key.

SOAP and SPONGE TRAYS and BASKETS

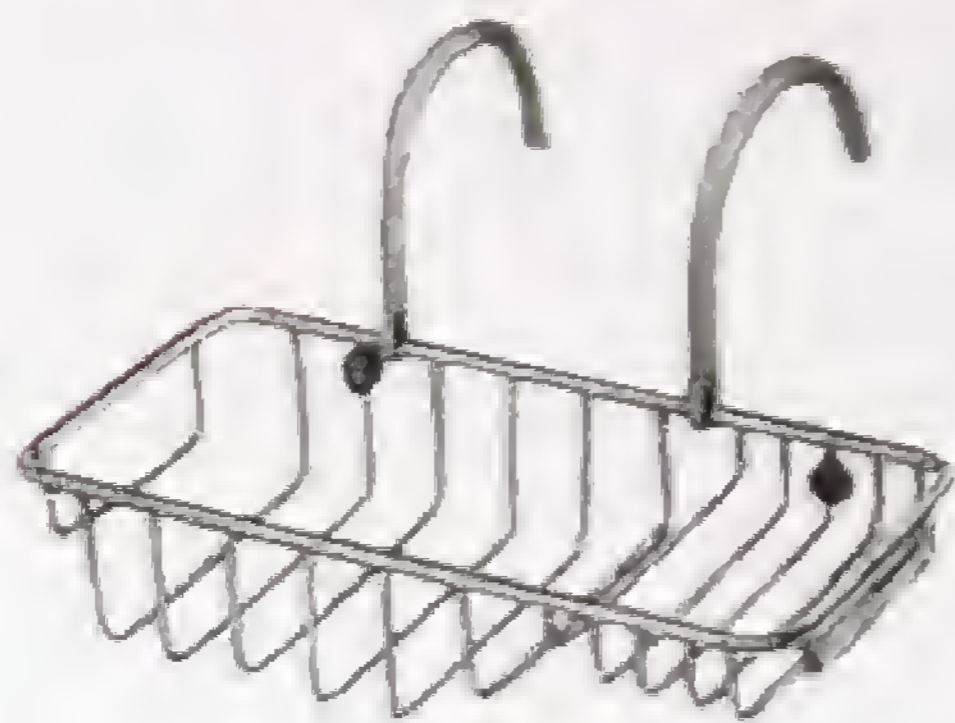

No. B 4080

Chromium-plated
SOAP AND SPONGE BASKET
With rubber-covered hangers.
Size: $10\frac{1}{2} \times 5 \times 2\frac{3}{8}$ in.



No. B 4081

Anodized aluminium
SOAP AND SPONGE BASKET
In green, gold, pink, or silver. Size: $9\frac{1}{2} \times 6 \times 2\frac{1}{2}$ in. This basket can be supplied in chromium-plated brass (extra).

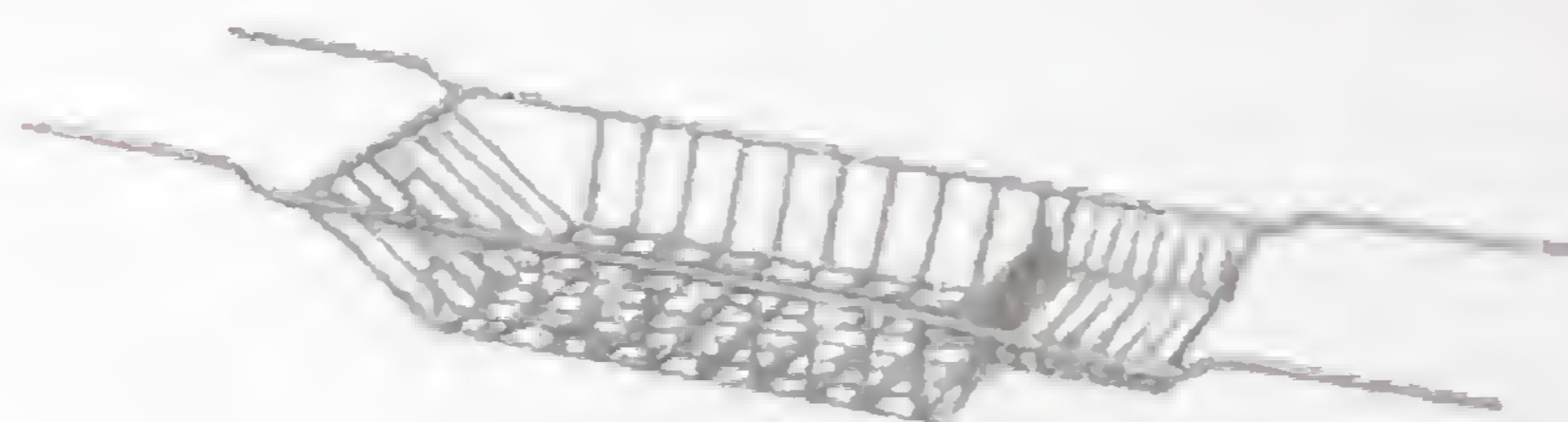

No. A 5975
BATH RACK

Coated with hard smooth glossy plastic.
Size: 30 in. long, $8\frac{1}{2}$ in. wide, 3 in. deep.



No. A 5976
BATH BASKET

Coated with hard smooth glossy plastic.
Size: $11\frac{3}{8}$ in. \times 5 in. \times 4 in. deep.

No. B 4082
Anodized aluminium
SOAP AND SPONGE TRAY
In green, gold, pink, or silver.
Length 26 to 31 in.; 6 in. wide;
3 in. deep.
This tray can be supplied in chromium-plated brass (extra).

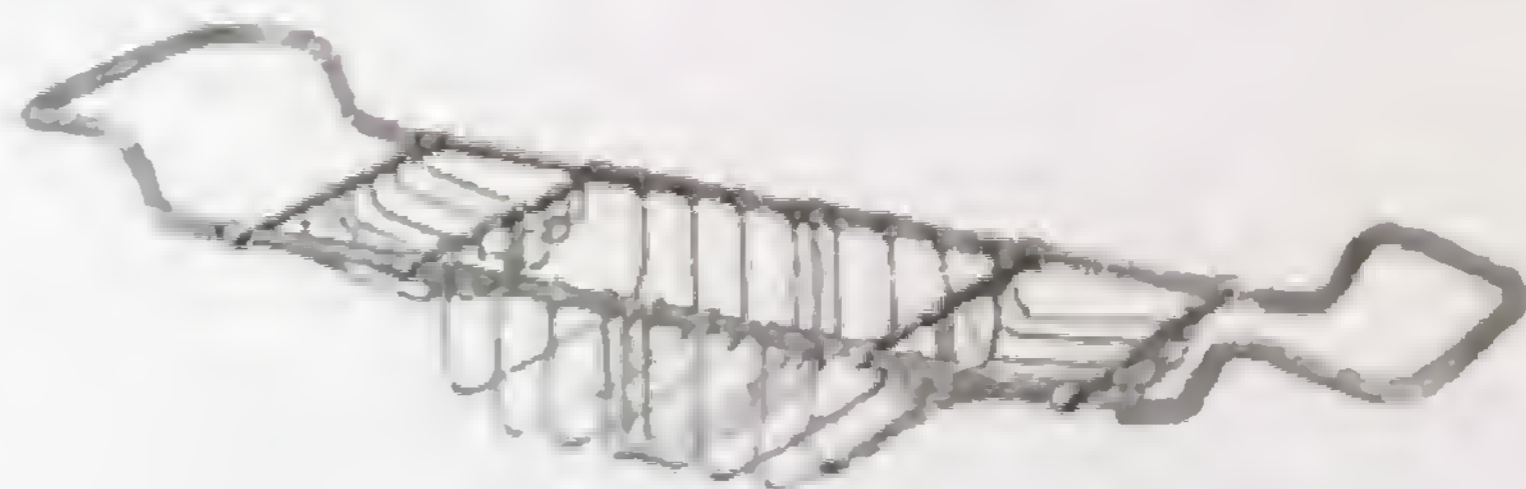

No. B 4084

Chromium-plated
ADJUSTABLE SOAP AND SPONGE TRAY

With double-sided reversible mirror, one side for magnifying, one side plain.
Length $27\frac{1}{2}$ in. to $30\frac{1}{2}$ in., $7\frac{1}{2}$ in. wide, 3 in. deep.

No. B 4085

Similar to above but without mirror and with perforated soap trays.

No. B 4083

Chromium-plated
ADJUSTABLE SOAP AND SPONGE TRAY

With double top frame.
Length 27 in. to 31 in., $7\frac{1}{2}$ in. wide, $3\frac{1}{2}$ in. deep.



SOAP DISPENSERS

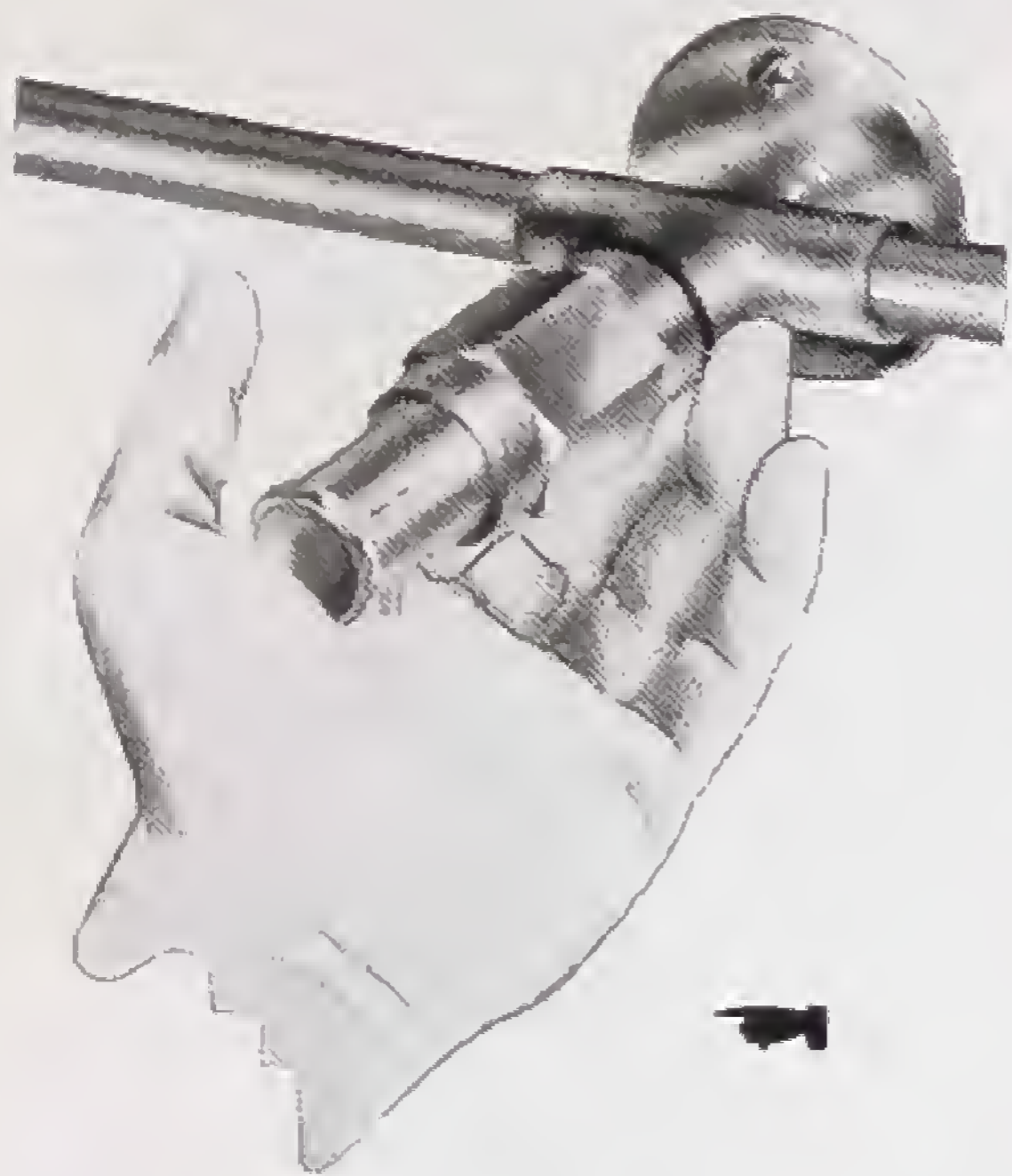

No. B 592
**LIQUID SOAP
LINE
DISPENSER**

With one depression of the valve, this fitting provides an adequate quantity of soap for normal purposes; it can be supplied to suit any number of basins, complete with pipe line, supply tank, and fittings. By using this system, a definite saving of soap is assured.



P 931
DISPENSER

Glass bowl type firmly secured by cement to black plastic top.



P 933
DISPENSER

Eminently suitable for positions where appearance is of importance, but where nozzle is not likely to be tampered with.



P 934
DISPENSER

This glass bowl is secured by screws and rubber washer making renewal of bowl, in case of breakage, very easy. Best quality chrome top and fittings.

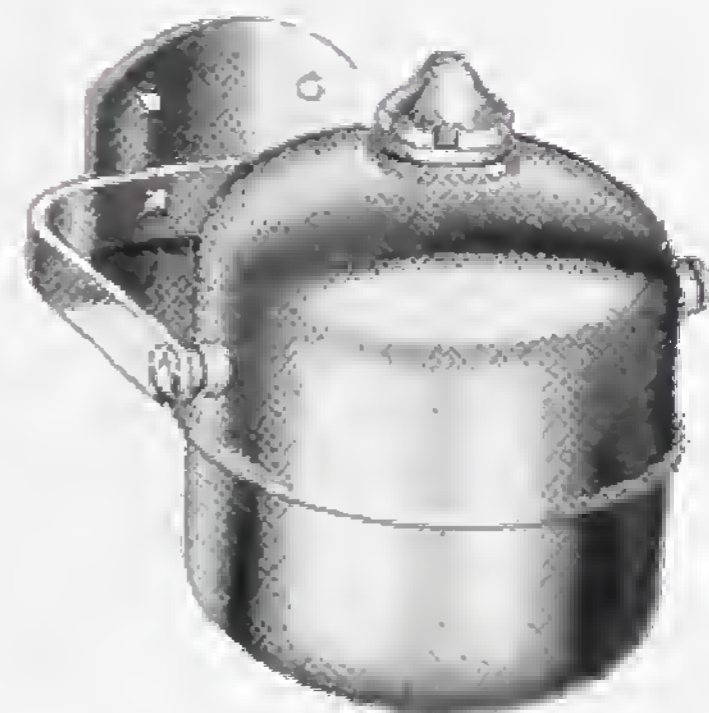

P 935
DISPENSER

Heavy type chrome plated on brass complete with fixing screws and key.

BEANCO LIQUID SOAP has many advantages as compared with the ordinary hard soaps in tablets or bars.

It is highly concentrated, and will not harm the most delicate skin. It is particularly useful and adapted for Welfare Departments, Public Institutions, Works, Hotels, Restaurants, Municipal and Commercial Offices. Doctors' and Dentists' Surgeries.

Unlike hard soap there are no waste ends, and it is not left in the water to waste away.

Made up in 1-gall. tins, 5 and 10-gall. drums and barrels of approx. 40 galls.

CELLAPURO BATH CLEANSER

The ideal non-scratch cleanser for all porcelain and enamelled surfaces.

Prepared specially from our own formula—the outcome of many years actual experience.

The regular use of Cellapuro will maintain the bright appearance of all sanitary appliances.

Supplied in canisters for domestic use or in bags containing 7 lb. 14 lb. 28 lb. 56 lb. or in 1 cwt. casks. Suitable for institutions, works, restaurants, municipal and commercial offices.

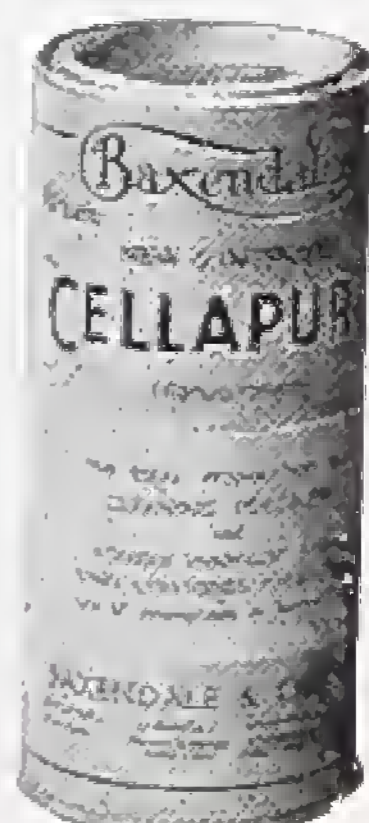
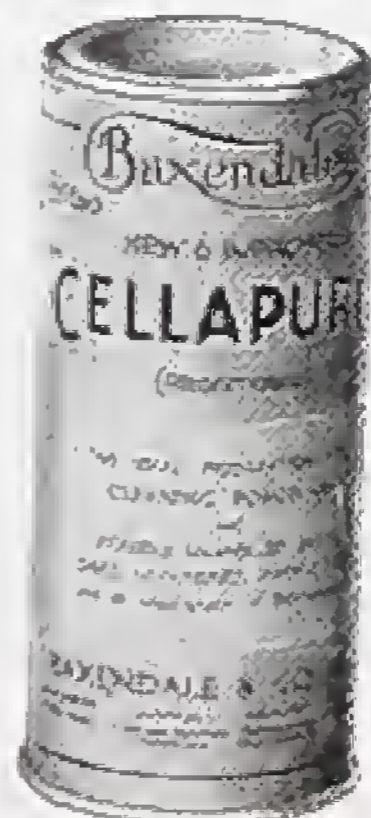

KITCHEN AND BATHROOM ACCESSORIES



No. B 4151

PRESSURE FILTER

Suitable for all purposes where an output of about 25 gallons per hour is sufficient.

Enamelled white inside and outside and with chromium-plated fittings.

Spare cylinders (extra).



No. B 1487

COMPRESSED CORK BATH MAT

Rounded Edges.

24 × 18 × 1 in.

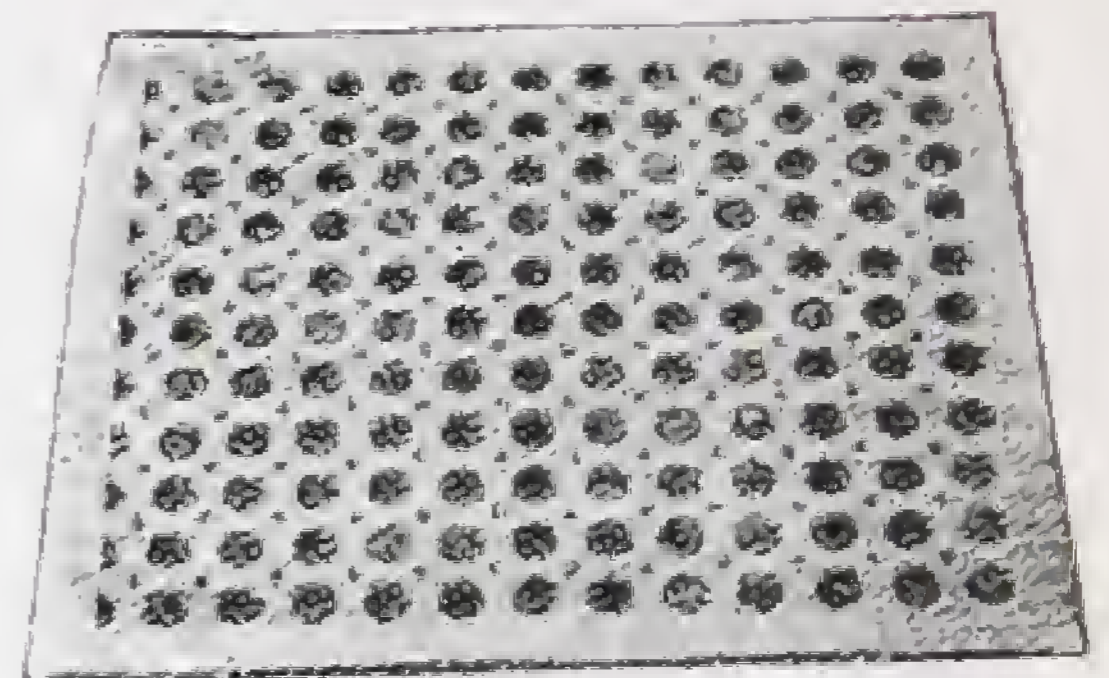

No. B 4223

INDIA-RUBBER SINK MAT

Extra heavy quality.

16 × 14 in. 14 × 12 in.

12 × 12 in.

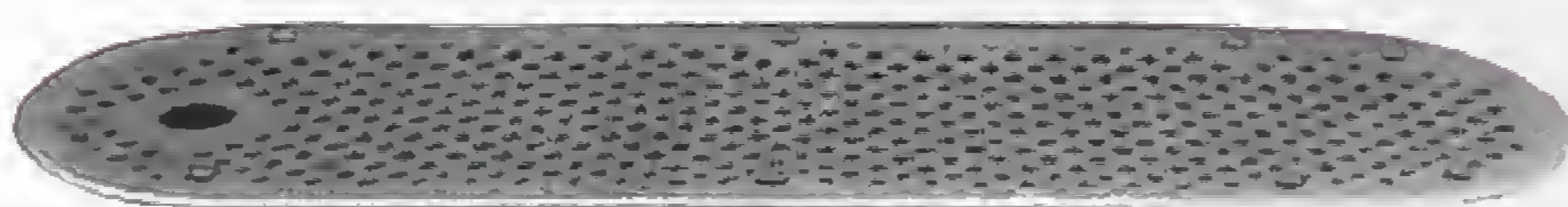

No. B 1486

INDIA-RUBBER MAT FOR INSIDE BATH

With suction grips.

36 × 14 in. 42 × 14 in.

No. B 4170

BATH SEAT

Enamelled in white or standard colours, with rubber-covered hangers, chromium-plated metal parts.

Size of Seat, 18 × 6 in.



BATHROOM ACCESSORIES



No. B 4087. **BATH TRAY**
In White or Black Plastic. Size : 29 × 7½ in.
NOTE.—This tray is not suitable for baths measuring less than 21¾ in. inside width.



No. A 5972
SOAP AND SPONGE RACK
Made in Alkathene which is pliable and unbreakable.
8 in. wide; 8½ in. high; 5½ in. long.
Colours : Natural, cream, green, and red.



No. A 5973
BATH EDGE SOAP AND SPONGE HOLDER
Made in Alkathene which is pliable and unbreakable.
6½ in. wide, 6 in. high, 5 in. long.
Colours : Natural, cream and green.



No. B 4185
WHITE-ENAMELLED WOOD LINEN BOX
With heavy cork seat.
Size : 15½ × 12½ in.; height 17 in.
As above
Seat 17½ × 12½ in.; Height 17 in.
Can also be supplied in green, blue, primrose, and ivory.



No. B 4089
BATHROOM STOOL
Chromium-plated, with cork seat; finest quality and distinctive design. Legs provided with rubber floor protectors.
Seat 11½ in. diameter; width overall 15½ in.; height 16½ in.

No. A 5974
"BEX" LAVATORY BRUSH CONTAINER

Made in Polythene
With Brush
15 7/16 in. high;
15 1/8 in. dia. Base.
Colours : Natural, blue, green and red.



BATHROOM FURNITURE

White enamelled sprayed finish on selected seasoned timber.
All metal fittings chromium-plated.

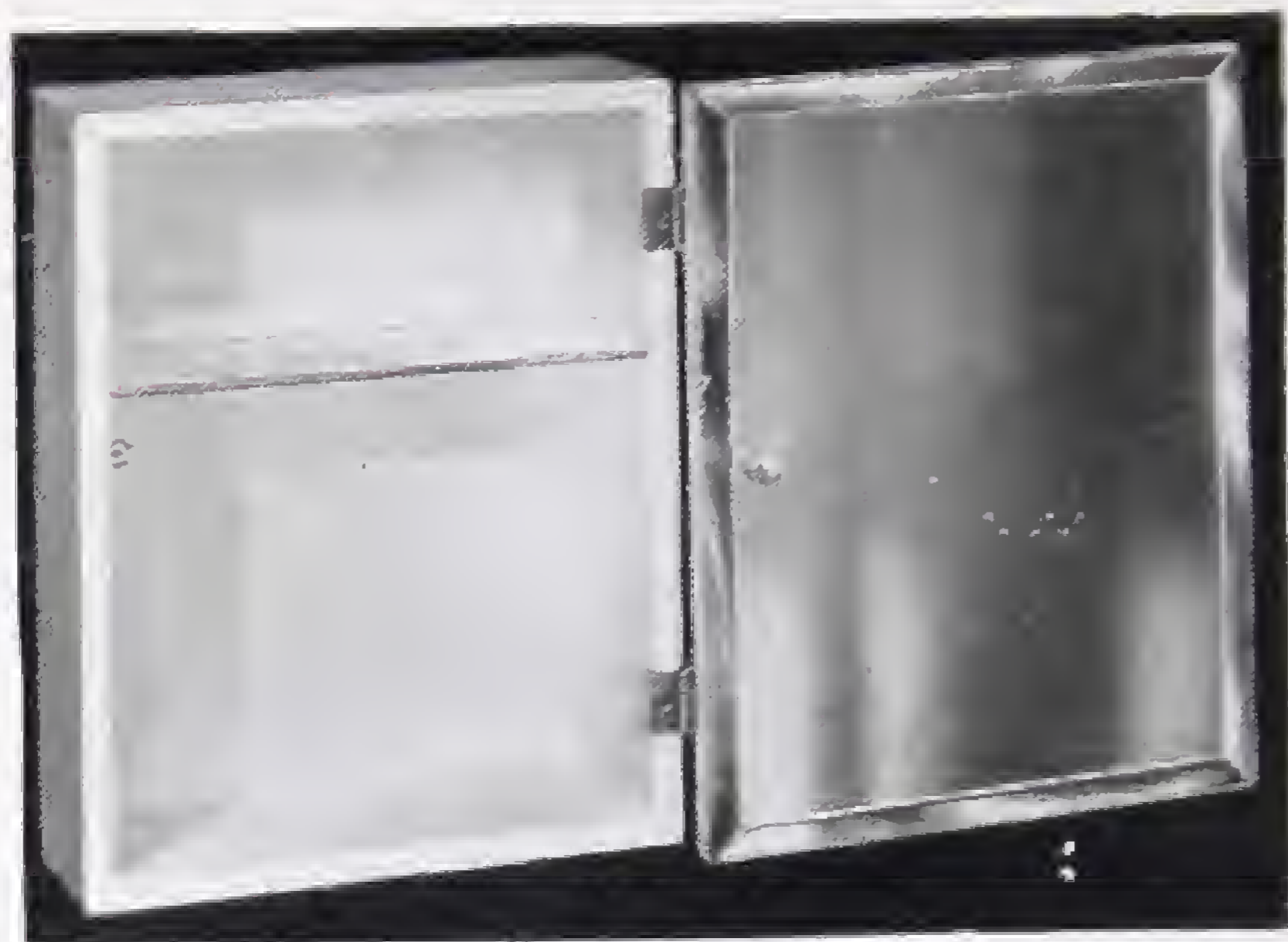

No. B 4186
**SWIVEL DOOR
FRAMELESS MIRROR
CABINET**

Door swivels to the right to give a clear opening.

Height	Width
12 in.	9 in.
13 in.	10 in.
15 in.	12 in.



No. B 4187
**RECESS FRAMELESS MIRROR
CABINET**

With plate glass shelf, chromium-plated fittings.

Height	Width
13 in.	10 in.
15 in.	12 in.
*17 in.	14 in.

* This model is supplied with two shelves.
N.B.—Recess in wall should be made 1 in. less than the overall sizes of the cabinet and 4 in. deep.



No. B 4182
**FRAMELESS MIRROR REVERSIBLE
CABINET**

With plate glass shelf and chromium-plated fittings.

Height	Width
12 in.	9 in.
13 in.	10 in.
15 in.	12 in.
*17 in.	14 in.

* This model is supplied with two shelves.



No. B 4188
**FRAMELESS MIRROR REVERSIBLE
CORNER CABINET**

With glass shelf and chromium-plated fittings.

Height	Width
13 in.	10 in.
15 in.	12 in.
*18 in.	12 in.

* This model is supplied with two shelves.
All the above can also be supplied in Standard Colours, Green, Blue, Primrose and Ivory.

BATHROOM FURNITURE

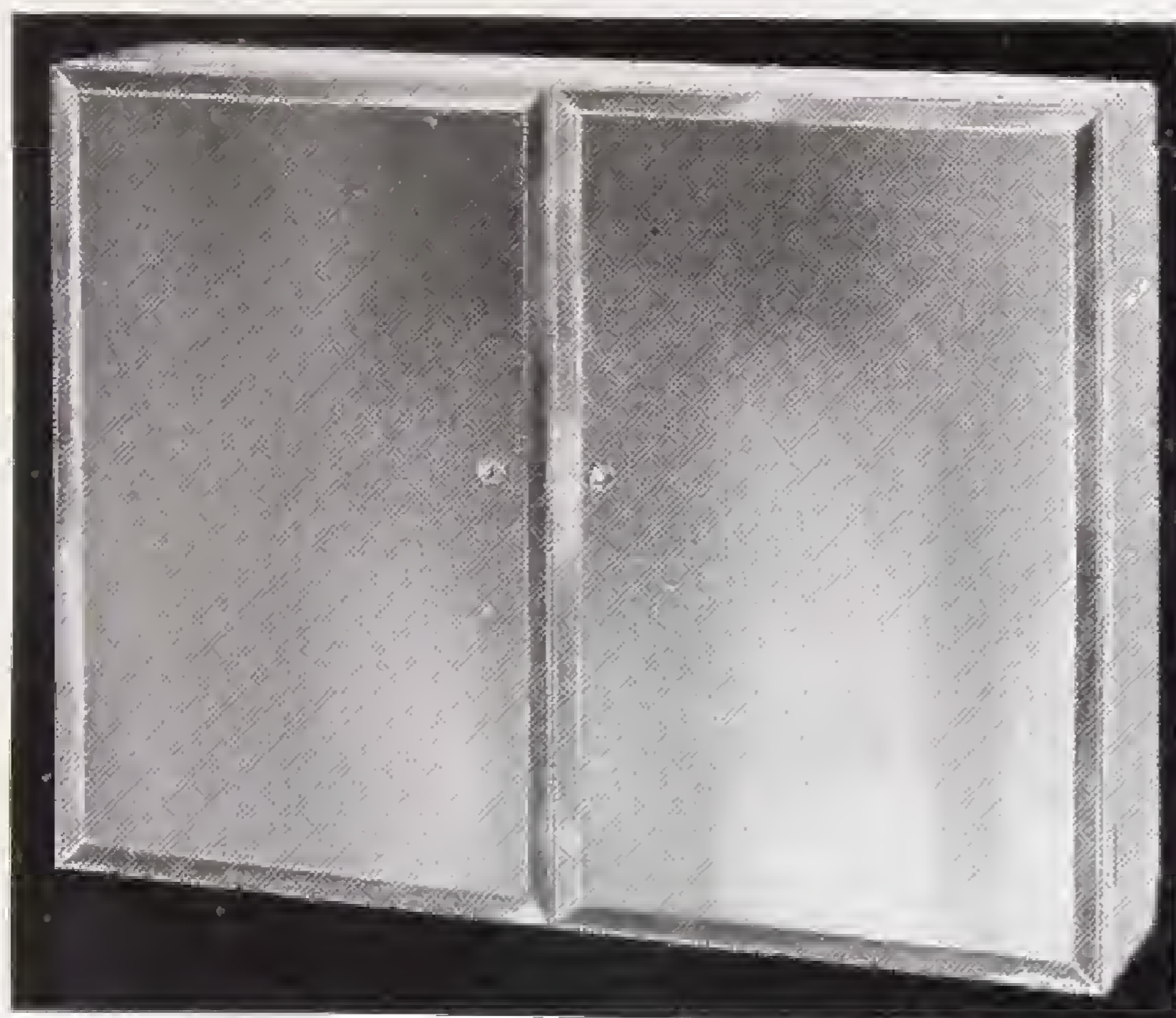

White enamelled sprayed finish on selected seasoned timber.

All metal fittings chromium-plated.

No. B 4195
CABINET

All Mirror Double Doors.

20 × 13 in.

24 × 15 in.

*28 × 17 in.

* This size has two shelves each side.

No. B 4196

RECESS CABINET

All-Mirror Double Doors.

20 × 13 in.

24 × 15 in.

*28 × 17 in.

* This size has two shelves each side.

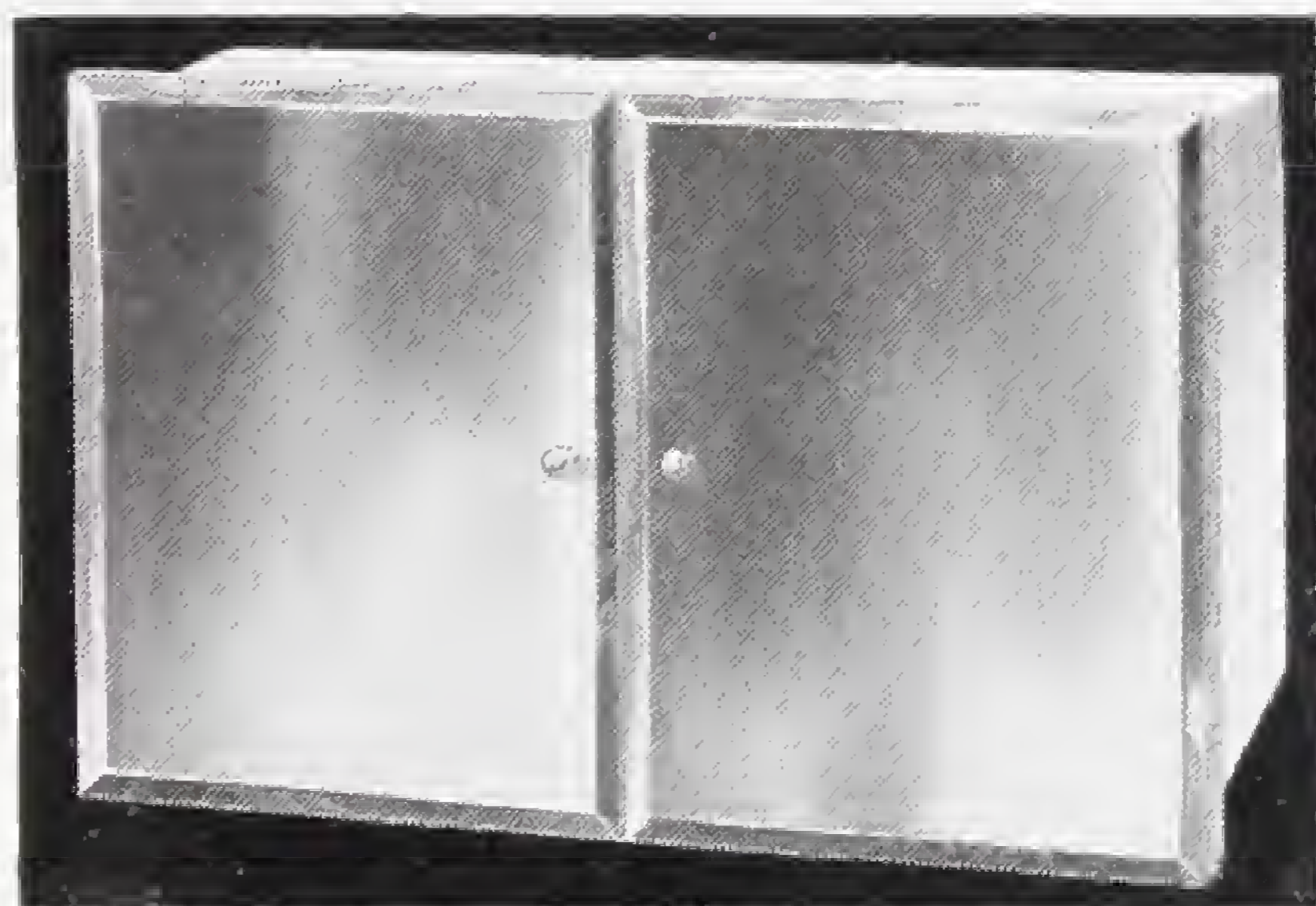

No. B 4197
TABLE CUPBOARD

Black Vitrolite Top.
Size : 16 × 13 in.
Height 28½ in.

No. B 4198
TABLE

Black Vitrolite Top.
Size 16 × 13 in.
Height 28½ in.



All the above can also be supplied in Standard Colours, Green, Blue, Primrose and Ivory.

BATHROOM FURNITURE

White enamelled sprayed finish on selected seasoned timber.



No. B 5041
STOOL
With Heavy
Cork Seat.
Seat 15½ in. ×
12½ in.
Height 17 in.



No. B 4192
STOOL WITH BOX
Heavy Cork Seat.
15½ in. × 12½ in. Height 17 in.

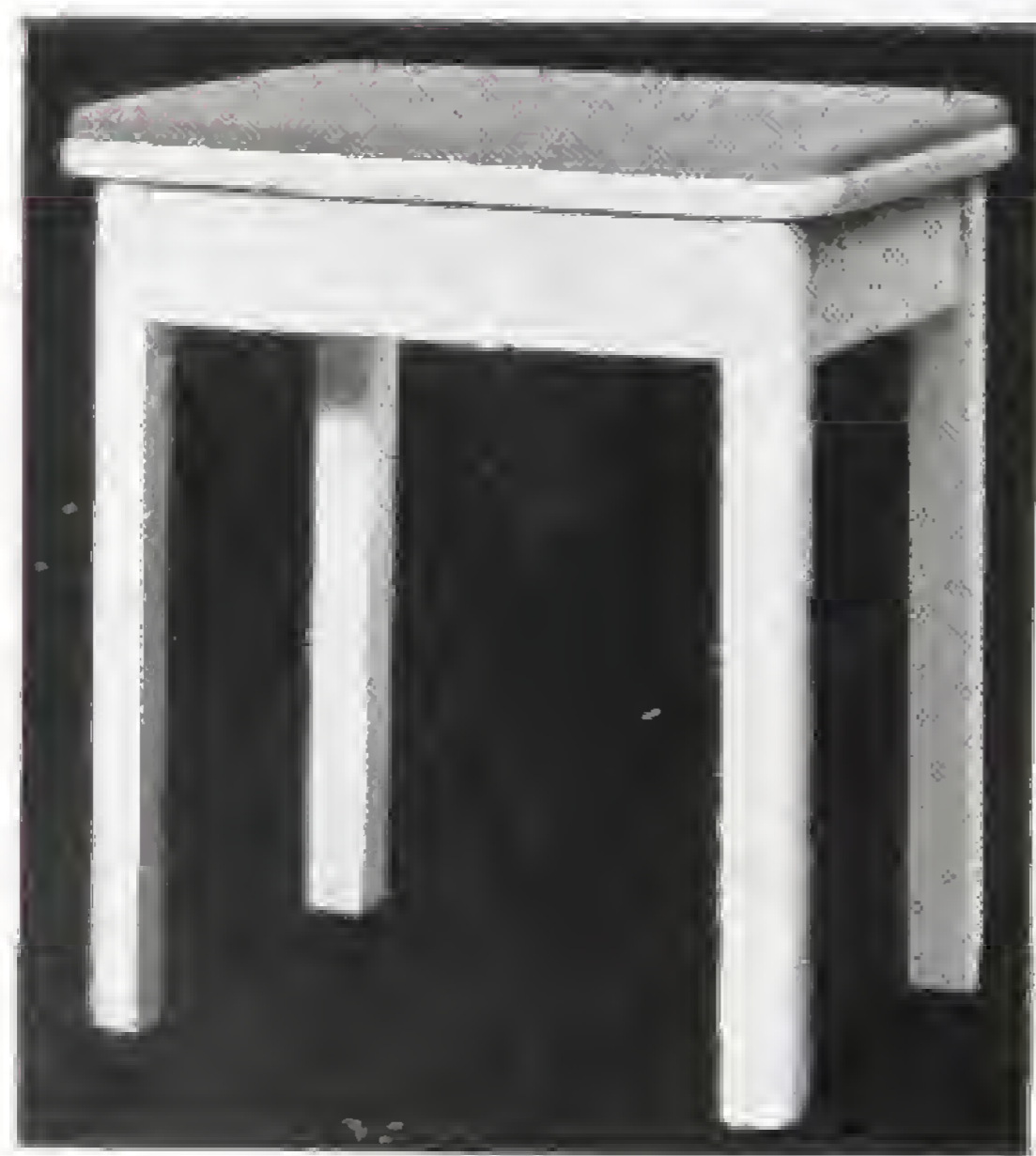

No. B 4193
STOOL
With Heavy
Cork Seat.
Seat 15½ in. ×
12½ in.
Height 17 in.



No. B 4194
CHAIR
With Heavy Cork Seat

All the above can also be supplied
in Standard Colours, Green, Blue,
Primrose and Ivory

BATHROOM MIRRORS

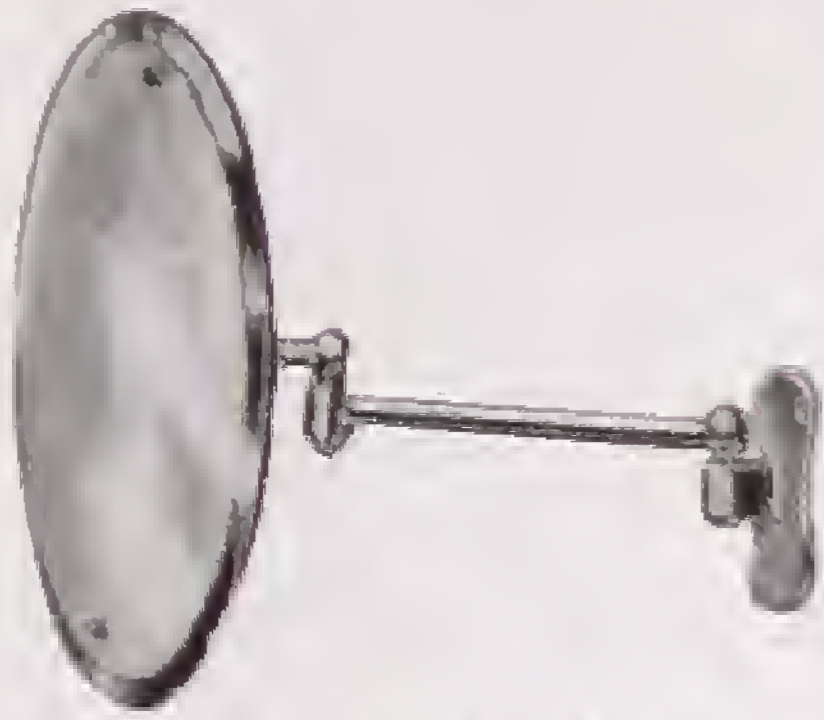

No. F 2794
SHAVING MIRROR

Strongly constructed, complete with ball joint at back and wall attachment. Swivel mirror. 9 in. diameter. Fittings chromium-plated.

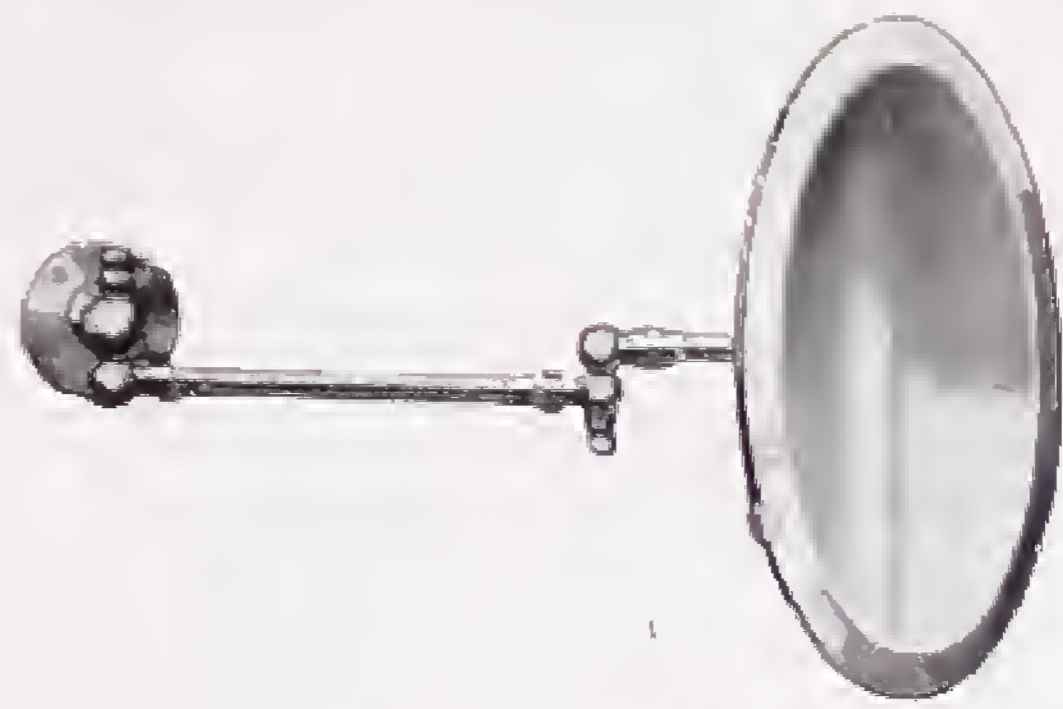

No. F 2795
SHAVING MIRROR

Bevelled edge. Rimless. With ball joints at back, may thus be placed at any angle. Ground and polished edges. 7-in. diameter. Fittings chromium-plated.

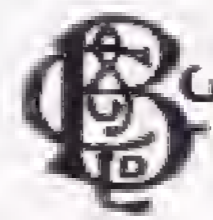
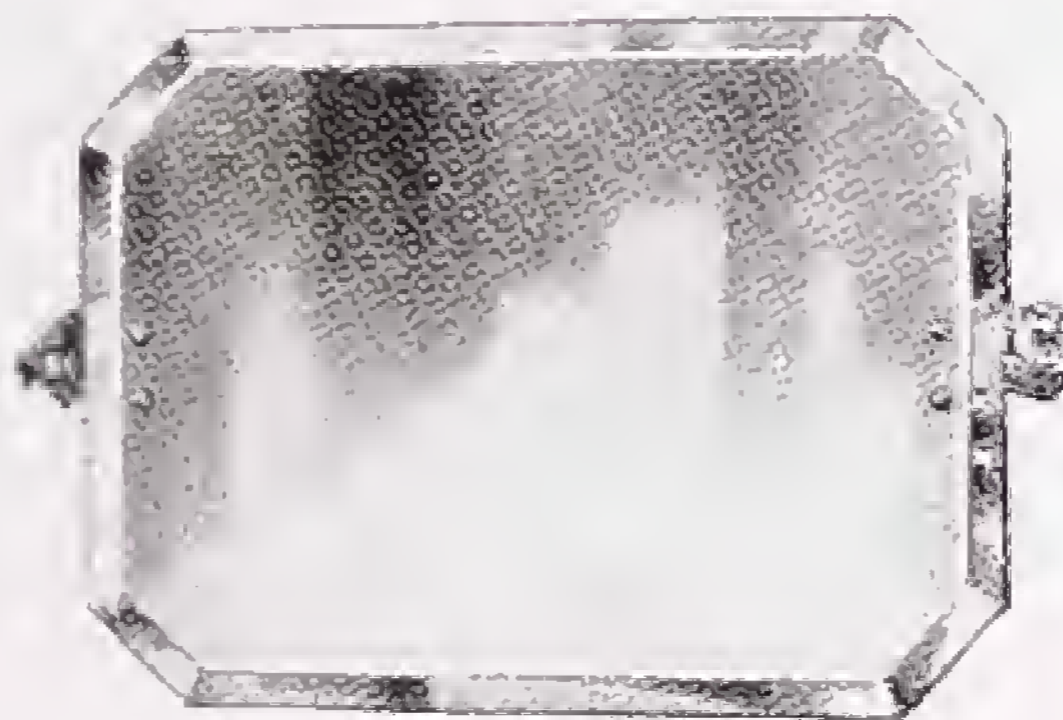

No. F 2776
MIRROR WITH SWING BRACKETS

Chromium-plated Fittings.
Sizes : 18 × 14 in. 16 × 12 in.



No. B 4459
WHITE VITROLITE SPLASH-BACK

Drilled one hole at each corner and supplied complete with fixing screws.

Sizes :
27 in. wide × 18 in. high
25 in. " × 18 in. "
25 in. " × 15 in. "
22 in. " × 15 in. "

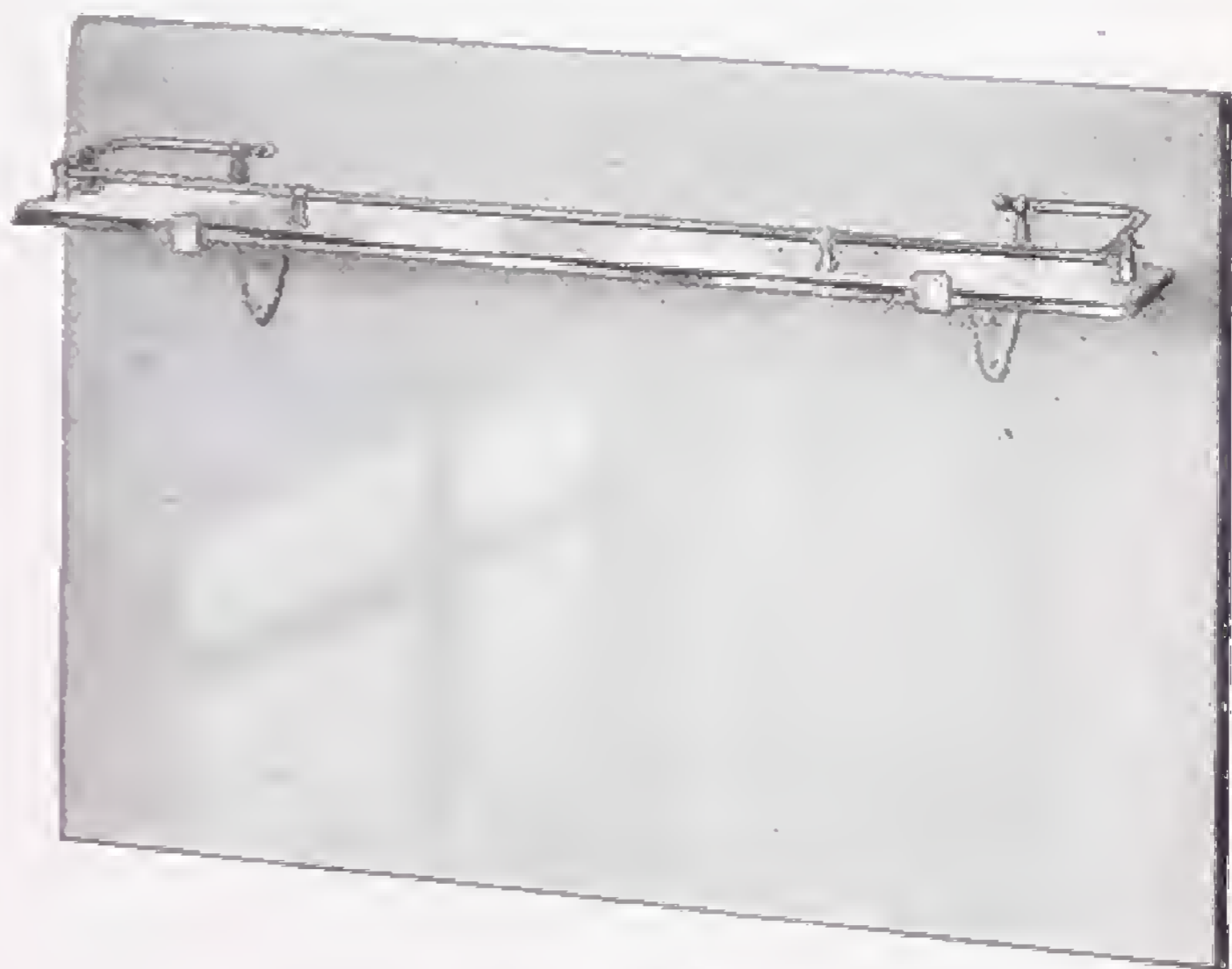

No. B 4061
WHITE VITROLITE SPLASH-BACK

With 5 in. Plate Glass Shelf and chromium-plated brackets and chromium-plated guard rail, with screws for fixing.

27 in. wide × 18 in. high
25 in. " × 18 in. "
25 in. " × 15 in. "
22 in. " × 15 in. "

Special sizes can be supplied to order.

BAXENDALE & CO. LTD.

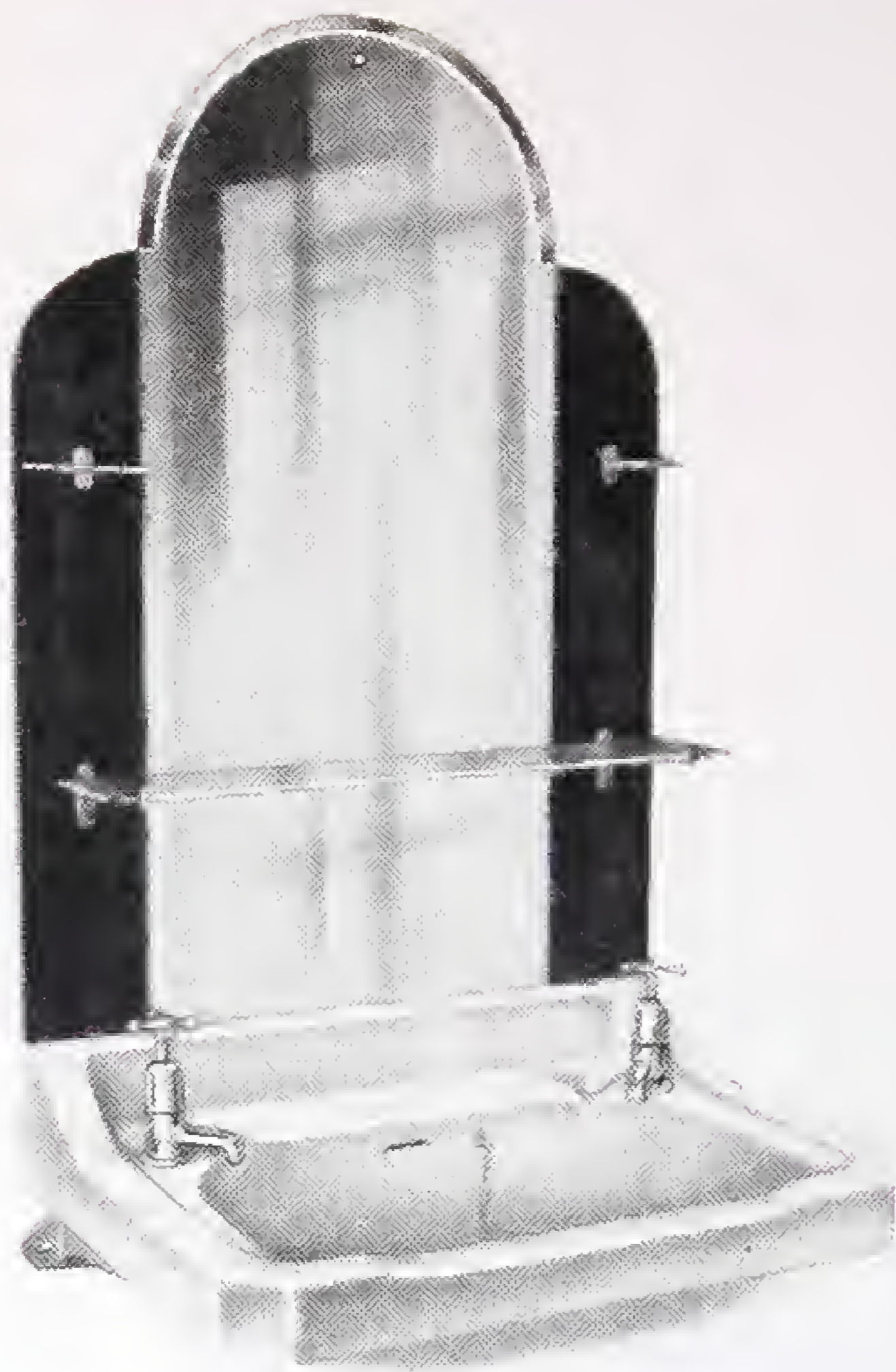

No. B 4521
MIRROR SPLASHBACK

Silvered centre panel with black side panels, plate glass shelf and chromium-plated brackets, tumbler holder and toothbrush holder.

Sizes :

Width	Height
25 in.	34 in.
22 in.	34 in.

Chromium-plated Guard Rail for Shelf can be supplied (extra).

No. B 4358a
ALL MIRROR SPLASHBACK
Partially bevelled edge and including brilliant cut design as illustrated ; damp-proof back.

Sizes :

Width	Height
25 in.	32 in.
22 in.	32 in.

No. B 4358
ALL MIRROR SPLASHBACK
As above but without brilliant cut design.

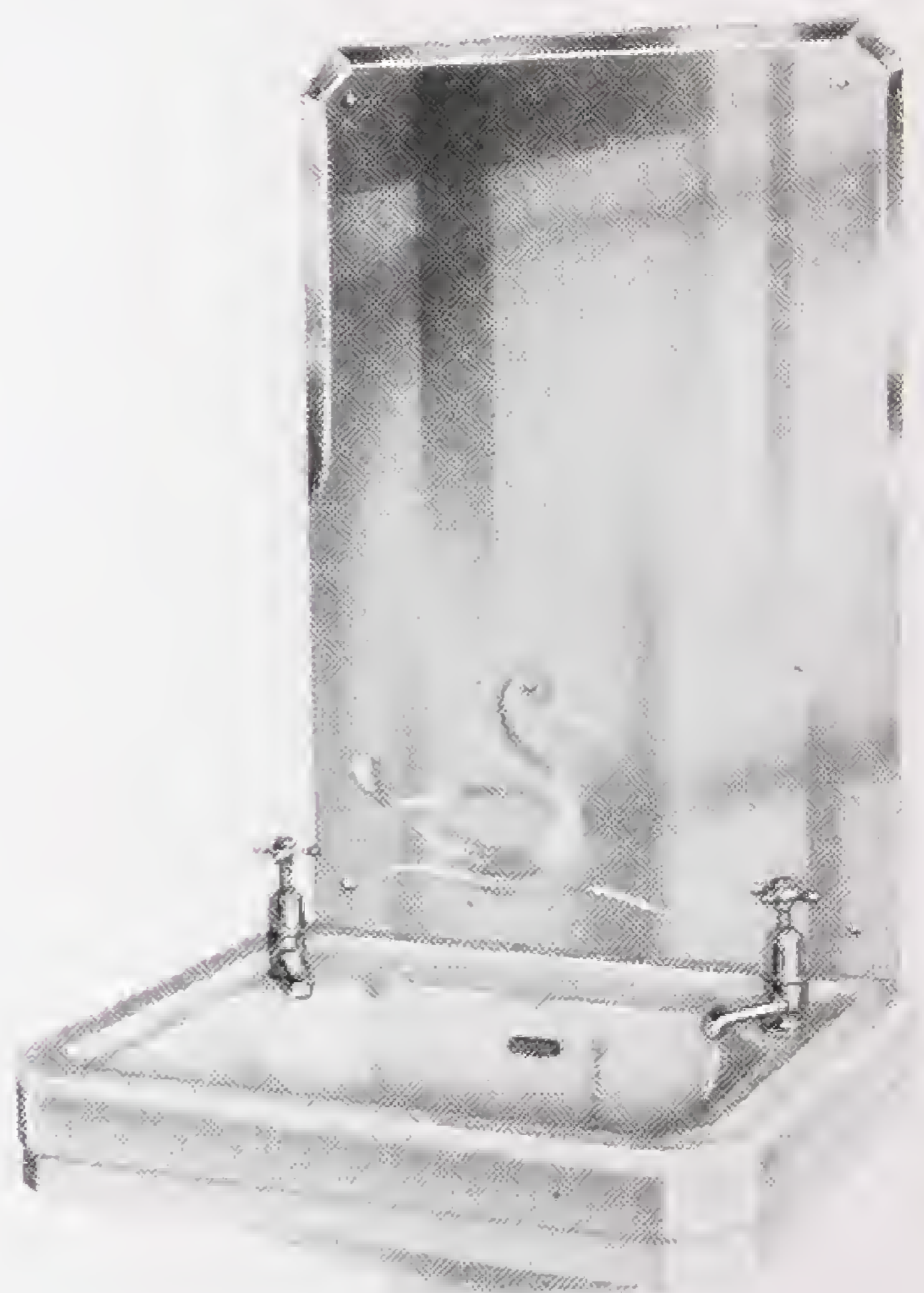

All Splashbacks are sent out with necessary fixing clips and/or chromium-plated screws.

MILLER STREET · MANCHESTER

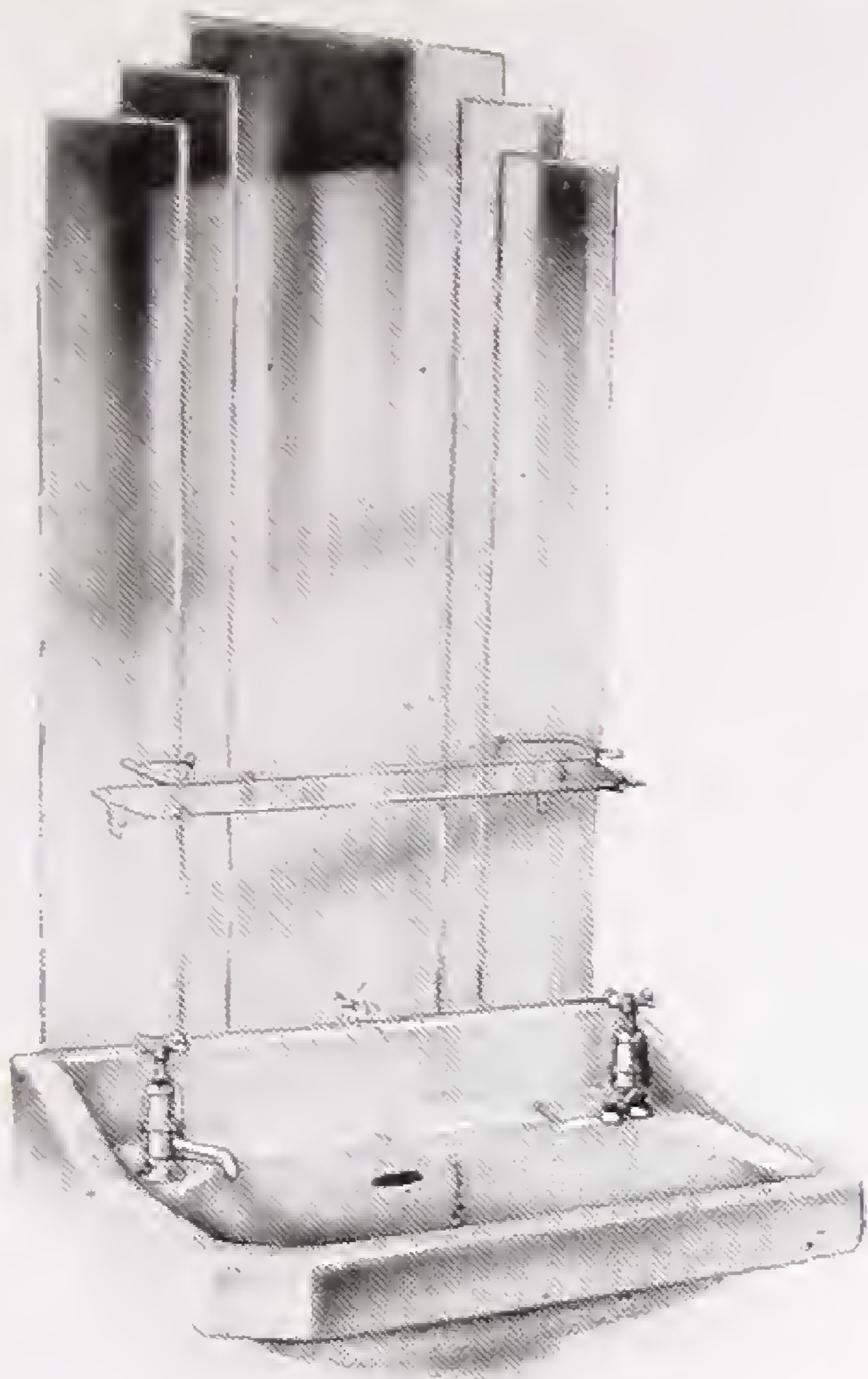

No. B 6273

MIRROR SPLASHBACK

“Stepped” top design with brilliant cut lines, plate glass shelf and chromium-plated guard rail.

Sizes :

Width	Height
25 in.	33 in.
22 in.	33 in.

No. B 4036

WHITE VITROLITE GLASS SPLASHBACK

Including 18 in. x 13 in. bevelled edge mirror on adjustable swing brackets ; shaped white shelf with chromium-plated brackets, tumbler holder and toothbrush holder.

Sizes :

Width	Height
25 in.	33 in.
22 in.	33 in.

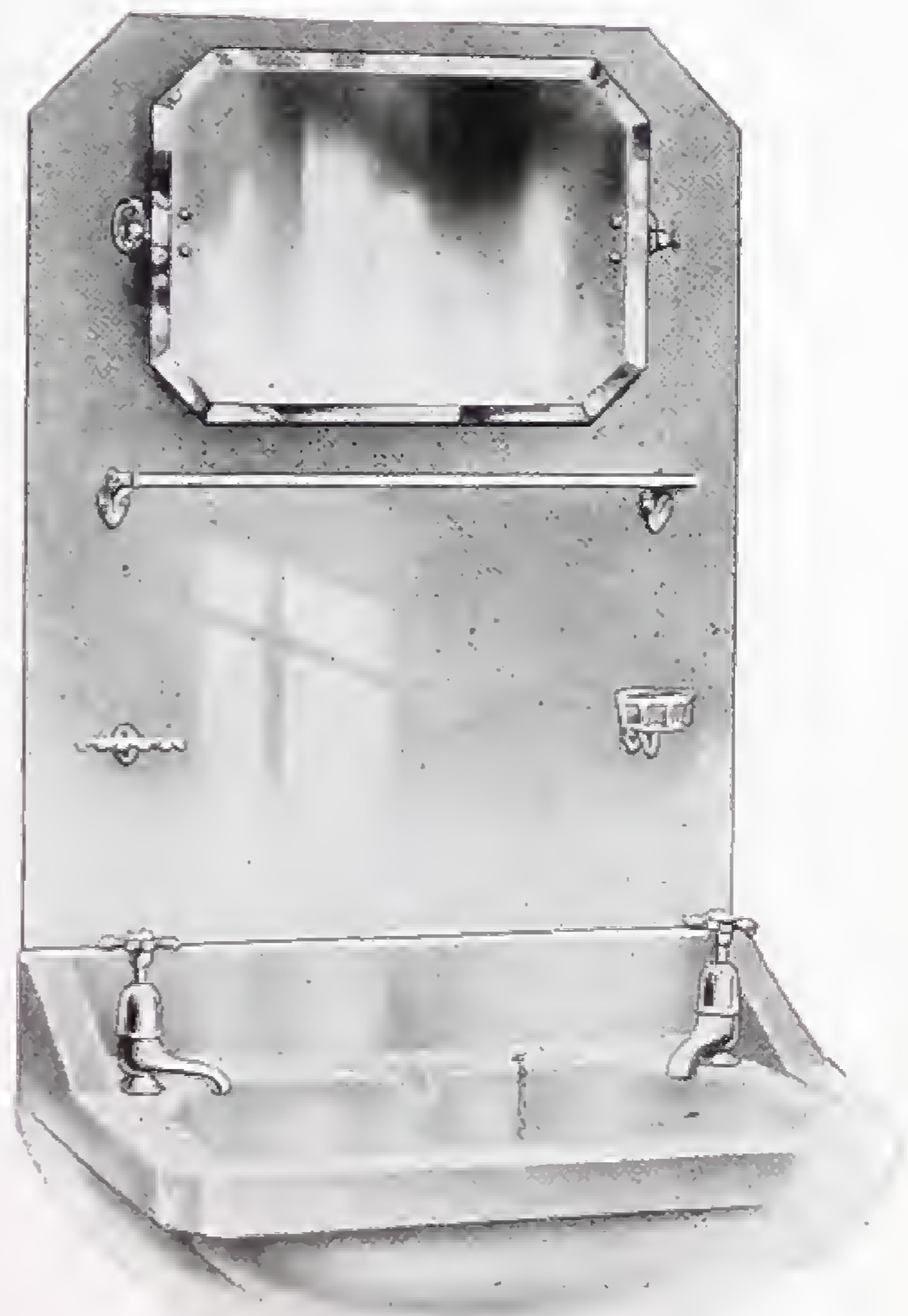

All Splashbacks are sent out with necessary fixing clips and/or chromium-plated screws.

No. B 6360

THE BUCKINGHAM SINK UNIT

Stainless steel sink with two fluted drainers, $\frac{1}{2}$ in. chromium-plated mixer fitting with swivel nozzle, $1\frac{1}{2}$ in. waste with plug and chain, enamelled wood cabinet finished in cream, white, green, or blue, with handles in black, red, green or blue. Features include two plain drawers, two cupboards with centre shelf and hinged doors.

Overall Sizes :

Length—4 ft. 6 in. Width—21 in. Height at Front—36 in.

Size of Bowl : 18 in. \times 15 in. \times 7 in.

No. B 6361

THE STIRLING SINK UNIT

Stainless steel sink with right or left hand fluted sink drainer, $\frac{1}{2}$ in. chromium-plated pillar mixer fitting with swivel nozzle, $1\frac{1}{2}$ in. waste with plug and chain, enamelled wood cabinet finished in cream, white, green, or blue with handles in black, red, green or blue. Special features include ample cupboard space with separate shelves for soap and cleaning materials, an extending working board which is released by a finger-touch on a novel press-button action ; refuse bin which can be opened by foot-pedal, and three vegetable containers are fitted behind the sliding doors.

Overall Sizes :

Length—3 ft. $1\frac{1}{2}$ in. Width—21 in. Height at Front—36 in.Size of Bowl : 18 in. \times 15 in. \times 7 in.

NEVASTANE SINK UNITS



THE BUCKINGHAM
No. B 6360



THE STIRLING
No. B 6361

No. B 6260

THE MILLERSDALE SINK UNIT

Stainless steel sink with two drainers, $\frac{1}{2}$ in. chromium-plated mixer fitting with swivel nozzle, $1\frac{1}{2}$ in. waste with plug and chain ; cream or white stove-enamelled *aluminium* cabinet with top drawer green baize lined for cutlery.

Overall Sizes :

Length—63 in. Width—21 in. Height at Front—36 in.
Size of Bowl : 19 in. \times 15 in. \times $7\frac{1}{2}$ in.

No. B 6260a

SINK UNIT as above but smaller size

Overall Sizes :

Length—54 in. Width—18 in. Height at Front—36 in.
Size of Bowl : $16\frac{1}{4}$ in. \times $13\frac{1}{2}$ in. \times $7\frac{1}{2}$ in.

No. B 6261

THE DOVEDALE SINK UNIT

Stainless steel sink with right or left-hand drainer, $\frac{1}{2}$ in. chromium-plated pillar mixer fitting with swivel nozzle, $1\frac{1}{2}$ in. waste with plug and chain, cream or white stove enamelled *aluminium* cabinet with 4-drawers and one cupboard. Top drawer green baize lined for cutlery.

Overall Sizes :

Length—42 in. Width—21 in. Height at Front—36 in.
Size of Bowl : 19 in. \times 15 in. \times $7\frac{1}{2}$ in.

No. B 6261a

SINK UNIT as above but narrower

Overall Sizes :

Length—42 in. Width—18 in. Height at Front—36 in.
Size of Bowl : $16\frac{1}{4}$ in. \times $13\frac{1}{2}$ in. \times $7\frac{1}{2}$ in.

No. B 6261b

SINK UNIT as above but shorter and narrower

Overall Sizes :

Length—36 in. Width—18 in. Height at Front—36 in.
Size of Bowl : $16\frac{1}{4}$ in. \times $13\frac{1}{2}$ in. \times $7\frac{1}{2}$ in.

Any of the above units can be supplied with a bucket swivel arm supply fitting if required. (Extra.)

All the above sink units can be fitted with a $1\frac{1}{2}$ in. crumb strainer waste *without overflow* at no extra cost.

PAUL SINK UNITS



THE MILLERSDALE SINK UNIT

No. B 6260



THE DOVEDALE SINK UNIT

No. B 6261

No. B 6374

LEIZURE SINK UNIT

Cream, White, Pastel Blue or Green porcelain-enamelled CULSYNK with right or left hand fluted drainer, $\frac{1}{2}$ in. chromium-plated hot and cold "Twinsal" mixer fitting, $1\frac{1}{2}$ in. waste with plug and chain, seasoned hardwood cabinet with high gloss crystal clear plastic finish bringing out the natural beauty of the wood grain.

Overall Sizes :—

Length—3 ft. 0 in., Width—18 in., Height at front—34 in.

Size of Bowl : 16 in. \times 12 in. \times 7 in.

No. B 6375

LEIZURE SINK UNIT

Stainless steel sink with two fluted drainers, $\frac{1}{2}$ in. chromium-plated hot and cold mixer fitting with swivel nozzle, $1\frac{1}{2}$ in. waste with plug and chain ; Cream, White, Pastel Blue, Green or Pink stove-enamelled steel cabinet with sound-deadened doors and drawers ; cutlery drawer green baize lined.

Overall Sizes :—

Length—5 ft. 3 in., Width—21 in., Height at Front—36 in.

Size of Bowl : $18\frac{1}{2}$ in. \times 15 in. \times 8 in.

The above units can be supplied with a bucket filling swivel arm supply fitting at an extra charge.

BAXENDALE & CO. LTD.

LEIZURE SINK UNITS



No. B 6374 SINK UNIT



No. B 6375 SINK UNIT

LANCASTER · LEEDS · BLACKPOOL

No. B 6362.

THE COUNTESS SINK UNIT

Stainless steel sink with right or left hand fluted drainer, $\frac{1}{2}$ in. chromium-plated 'Twinseal' hot and cold swan neck supply taps, $1\frac{1}{2}$ in. waste with plug and chain.

Cabinet constructed of sound seasoned wood, modern design with toe recess ; fitted with two doors with double ball catch locking action and internal recessed half shelf.

Finished cream or white enamel with contrasting handles.

Overall Sizes :—

Length—3 ft. 6 in. Width—21 in. Height at Front—36 in.

Size of Bowl : 21 in. \times 15 in. \times $7\frac{1}{2}$ in.

The above unit can also be supplied with cream, white, or green porcelain-enamelled sink top.

No. B 6363.

THE PRINCESS SINK UNIT

Cream, white, or green porcelain-enamelled steel sink with two fluted drainers, $\frac{1}{2}$ in. chromium-plated hot and cold high-necked pillar taps, $1\frac{1}{2}$ in. waste with plug and chain ; cream or white enamelled seasoned wood cabinet with contrasting handles.

Expertly designed to give maximum drawer and cupboard space.

Overall Sizes :

Length—5 ft. 3 in. Width—21 in. Height at Front—36 in.

Size of Bowl : 21 in. \times 15 in. \times $7\frac{1}{2}$ in.

The above units can be supplied with pillar mixer fittings with swivel nozzle as an alternative to the taps illustrated.

BAXENDALE & CO. LTD.

EASICLENE SINK UNITS



THE COUNTESS SINK UNIT
No. B 6362



THE PRINCESS SINK UNIT
No. B 6363

LIVERPOOL · EDINBURGH · DUBLIN

No. B 6269 STAINLESS STEEL SINK

Single drainer model, available for either right or left-hand fixing ; prepared for but not including supply fittings, $1\frac{1}{2}$ in. waste, plug and chain.

Length—42 in. Width—21 in. Size of Bowl : $18\frac{1}{2}$ in. \times 15 in. \times 8 in.

No. B 6270 STAINLESS STEEL SINK

Double drainer model, prepared for but not including supply fittings, $1\frac{1}{2}$ in. waste, plug and chain.

Length—63 in. Width—21 in. Size of Bowl : $18\frac{1}{2}$ in. \times 15 in. \times 8 in.

No. B 6271 STAINLESS STEEL SINK

Double drainer, double well model, prepared for but not including supply fittings, two $1\frac{1}{2}$ in. wastes, plugs and chains.

Length—84 in. Width—21 in.

Size of Bowls :

Left-hand : 15 in. \times 14 in. \times 7 in. Right-hand : $18\frac{1}{2}$ in. \times 15 in. \times 8 in.

No. B 6272 PORCELAIN ENAMELLED STEEL SINK

Single drainer model available for either right or left-hand fixing ; prepared for but not including supply fittings, $1\frac{1}{2}$ in. waste, plug and chain ; finished in white, green, cream, or blue.

Length—42 in. Width—21 in. Size of Bowl : 20 in. \times 15 in. \times 8 in.

Any of the above sinks can be supplied with chromium-plated mixer fitting with single swivel supply nozzle.

SINK UNIT TOPS

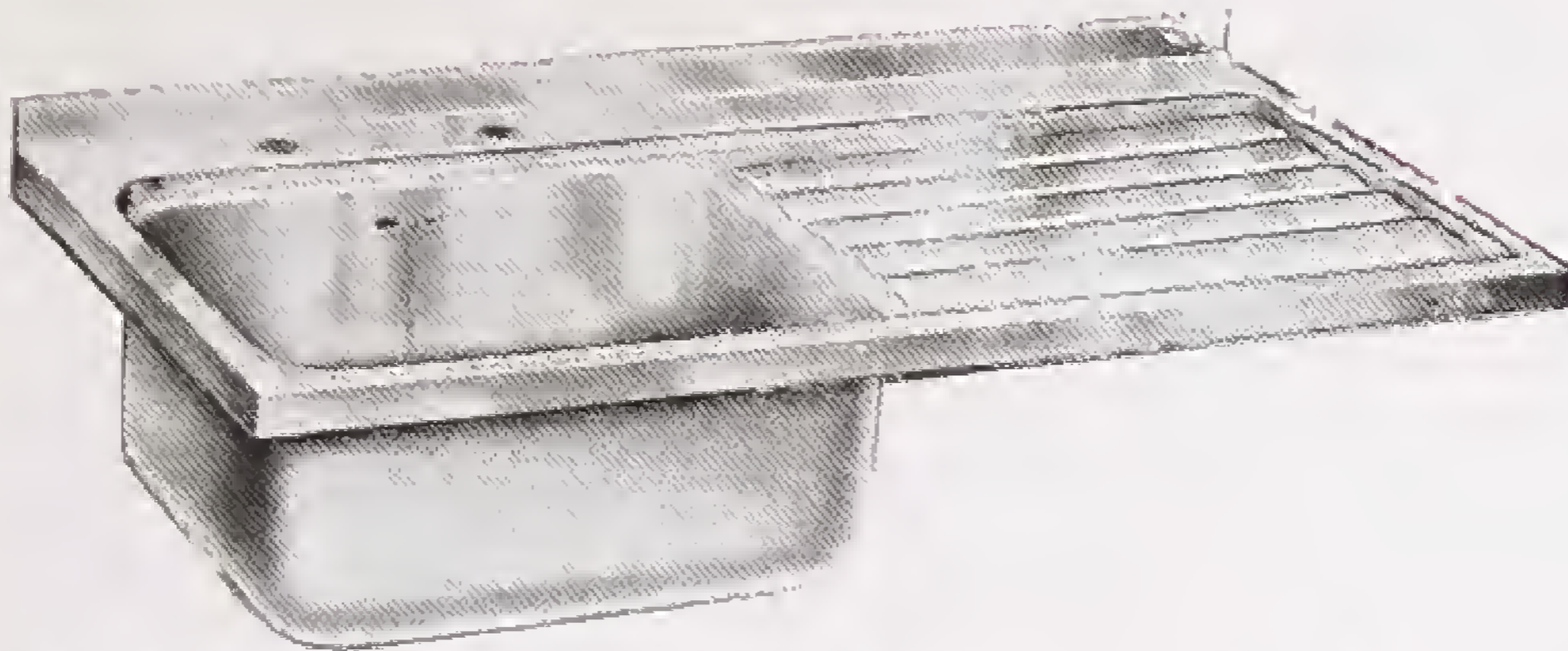

STAINLESS STEEL SINK WITH SINGLE DRAINER
No. B 6269



STAINLESS STEEL SINK WITH DOUBLE DRAINERS
No. B 6270

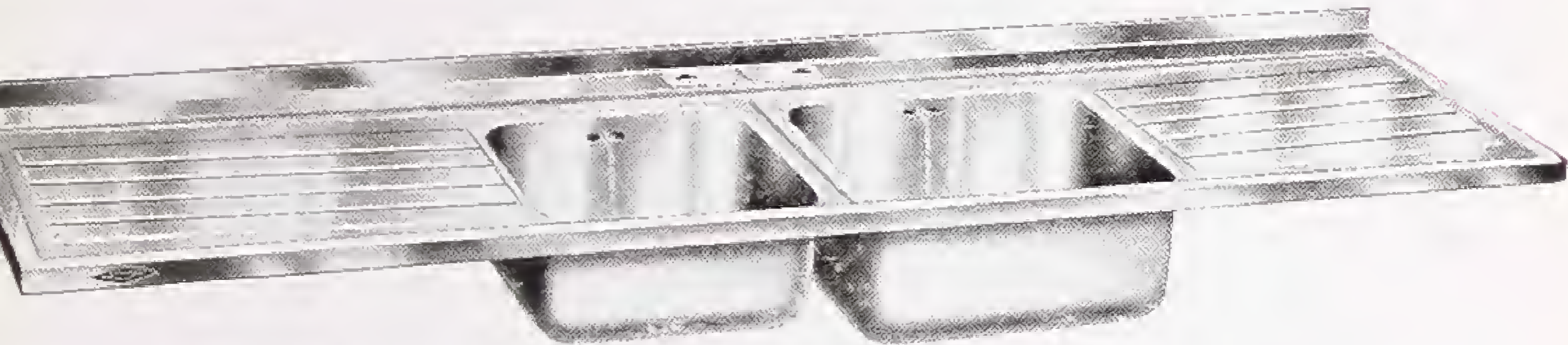

**STAINLESS STEEL SINK WITH TWO BOWLS AND
DOUBLE DRAINERS**
No. B 6271

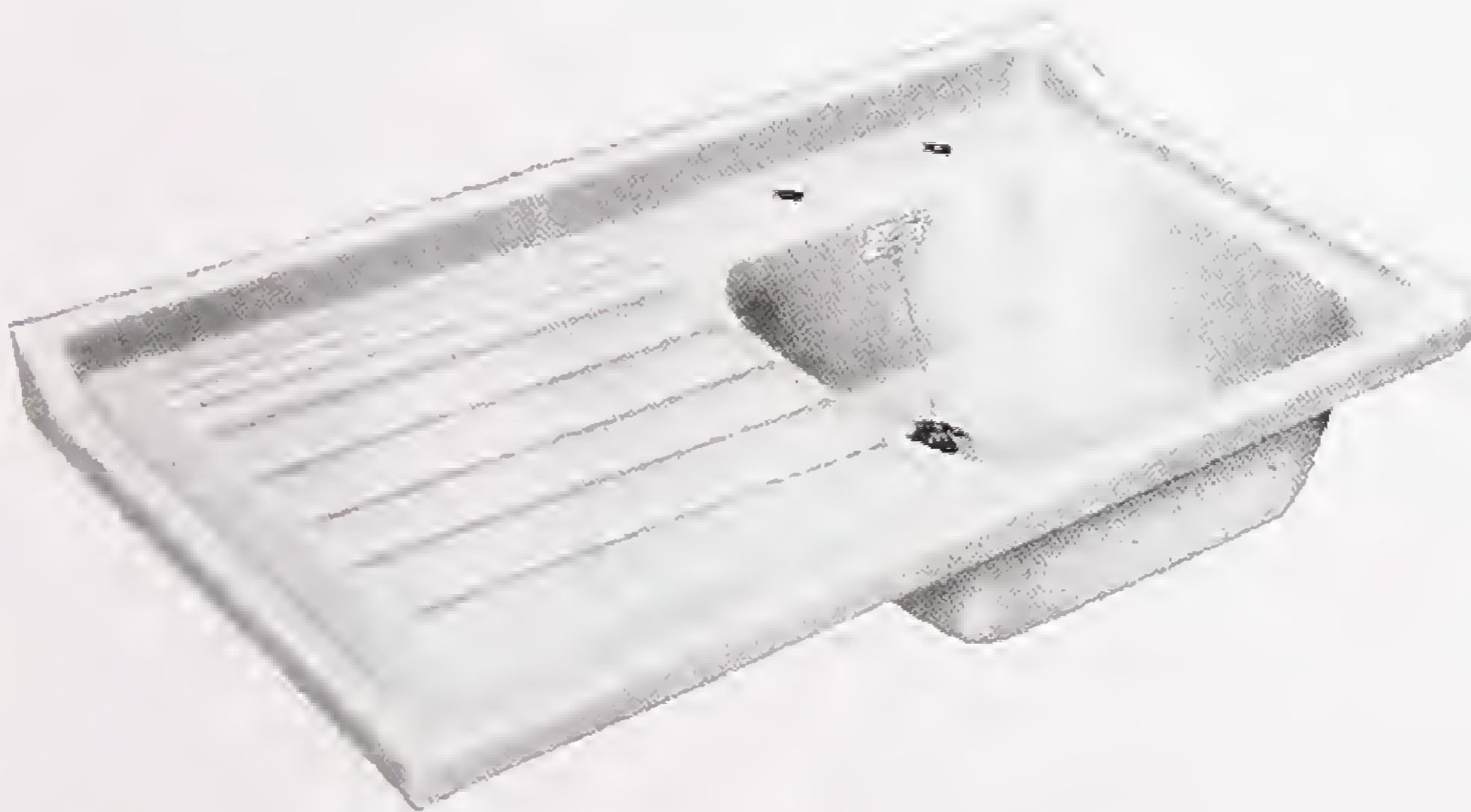

PORCELAIN-ENAMELLED STEEL SINK WITH SINGLE DRAINER
No. B 6272

FOR BAR SINKS see Page 220.

No. B 2477.

COMBINATION SINK AND WASHTUB SET

One-piece white glazed heavy fireclay with ledge on back providing for two taps to each compartment. Outlets discharge into mutual waste chamber and overflow formed in ware. Complete with galvanized wringer fixture ; chromium-plated wastes with plugs, chains, and stays. Coated cast-iron flanged trap and wall bend, white porcelain-enamelled or plain-painted cast-iron pillar legs with bearers.

$\frac{1}{2}$ in. hot and cold chromium-plated inclined pillar taps to each compartment.

Overall Sizes :

48 in. \times 20 in. \times 15 in.

No. B 2478.

COMBINATION SINK AND WASHTUB SET

Two-piece white glazed heavy fireclay ; white porcelain-enamelled or plain-painted cast-iron pillar legs to support with bearers to wall, galvanized wringer fixture ; combined skirting and pipe box in rustless plastic, or white porcelain-enamelled steel, hot and cold copper supply pipes and chromium-plated hot and cold bib taps for each compartment.

Two chromium-plated brass waste fittings with plugs, chains and stays and coated cast-iron waste pipes with trap and wall bend.

Overall Sizes :

Sink 24 in. \times 20 in. \times 10 in.Tub 24 in. \times 20 in. \times 12 in.

This sink and washtub set is normally supplied without the special pipe box unless this is specifically ordered. (Extra)

SINK AND WASHTUB SETS



ONE-PIECE TUB AND SINK
No. B 2477

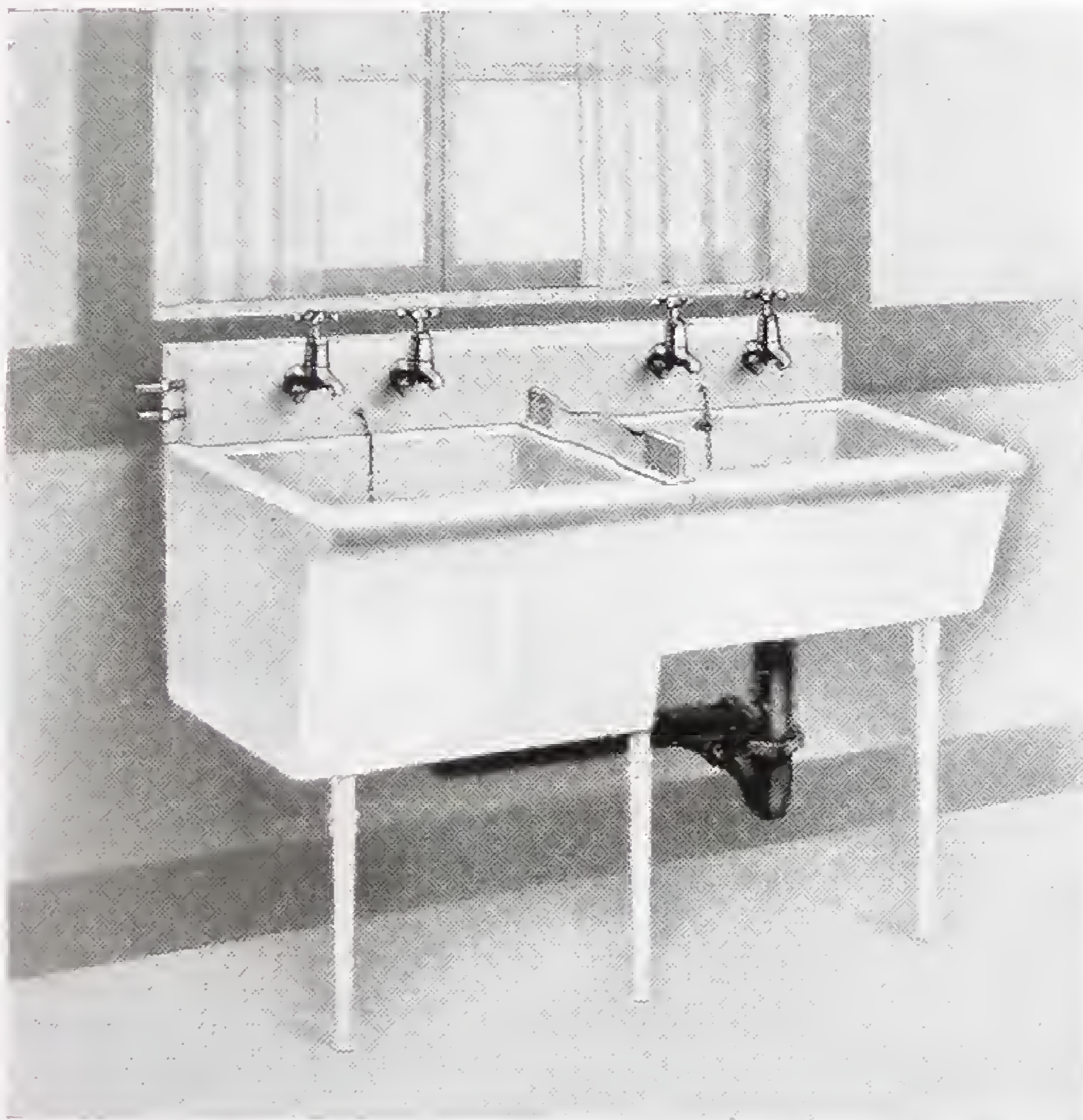

TWO-PIECE TUB AND SINK SET
No. B 2478

No. B 6268 SHELF PATTERN SINK

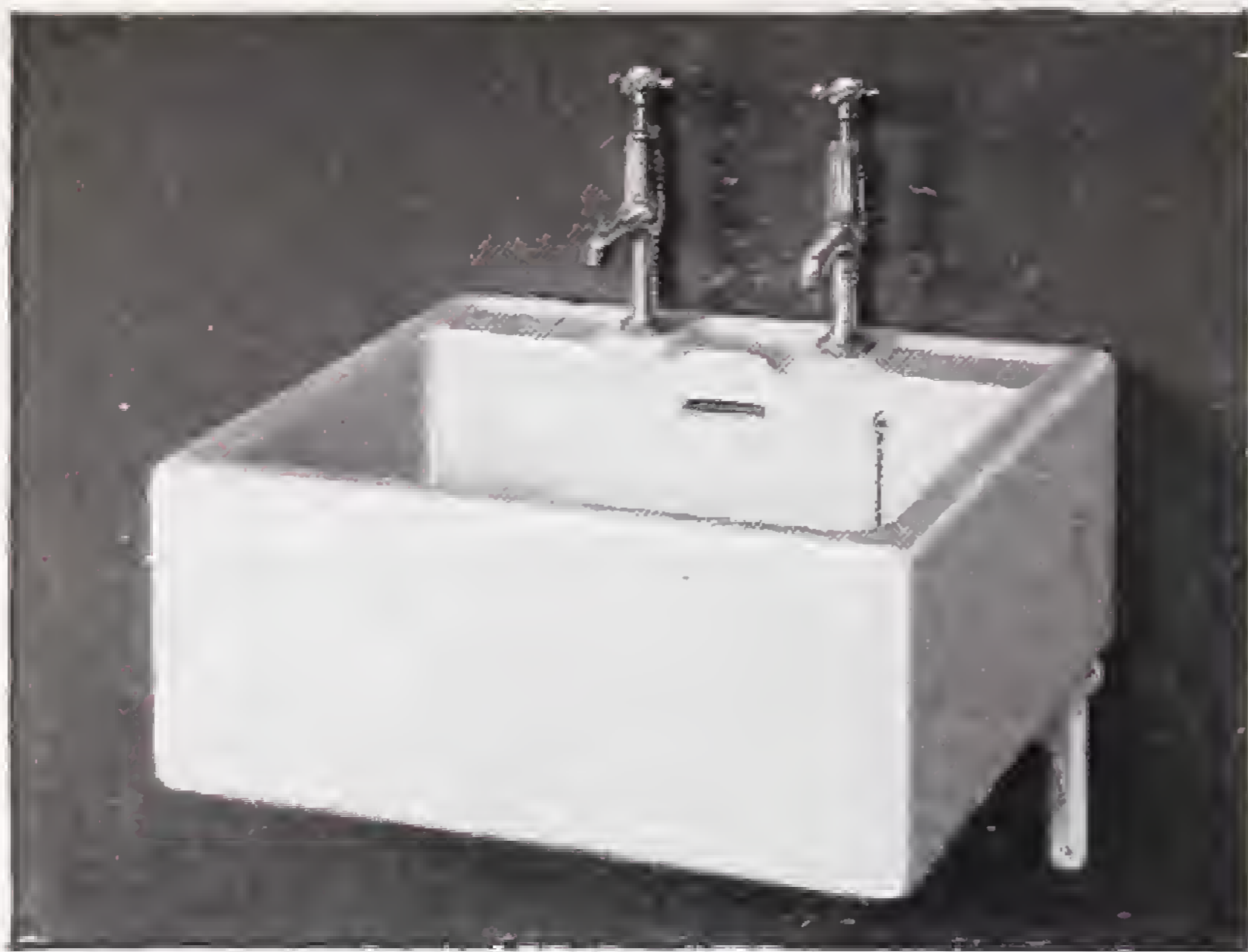

White glazed heavy fireclay with slot overflow, including $\frac{1}{2}$ in. chromium-plated hot and cold high-waisted pillar taps, $1\frac{1}{2}$ in. waste with plug and chain, and cast-iron cantilever brackets.

Overall Sizes :

24 in. \times 21 in. \times 10 in.

30 in. \times 21 in. \times 10 in.

No. B 2422 COMBINATION SINK

White glazed heavy fireclay with accessible weir overflow and fluted drainer ; can be fixed either right or left-hand, including $\frac{1}{2}$ in. chromium-plated hot and cold bib taps, $1\frac{1}{2}$ in. waste with plug and chain, and painted cast-iron cantilever brackets.

Overall Sizes :

30 in. \times 18 in. \times $9\frac{1}{2}$ in.

36 in. \times 18 in. \times $9\frac{1}{2}$ in.

42 in. \times 18 in. \times $9\frac{1}{2}$ in.



No. B 4464 BELFAST SINK



White glazed heavy fireclay with accessible weir overflow; can be fitted either right or left-hand, with fittings including $\frac{1}{2}$ in. chromium-plated hot and cold bib taps, $1\frac{1}{2}$ in. waste with plug and chain, and painted cast-iron cantilever brackets.

Overall Sizes :

18 in. \times 15 in. \times 8 in.
 24 in. \times 16 in. \times 8 in.
 24 in. \times 16 in. \times 10 in.

24 in. \times 18 in. \times 10 in.
 30 in. \times 18 in. \times 10 in.
 36 in. \times 20 in. \times 10 in.

No. B 6357

A.B.M. "PARSALL" SINK

White glazed heavy fireclay with accessible weir overflow combined with waste in centre at back, similar to the Belfast sink but more attractive in appearance and giving facilities for the use of a soap tray.

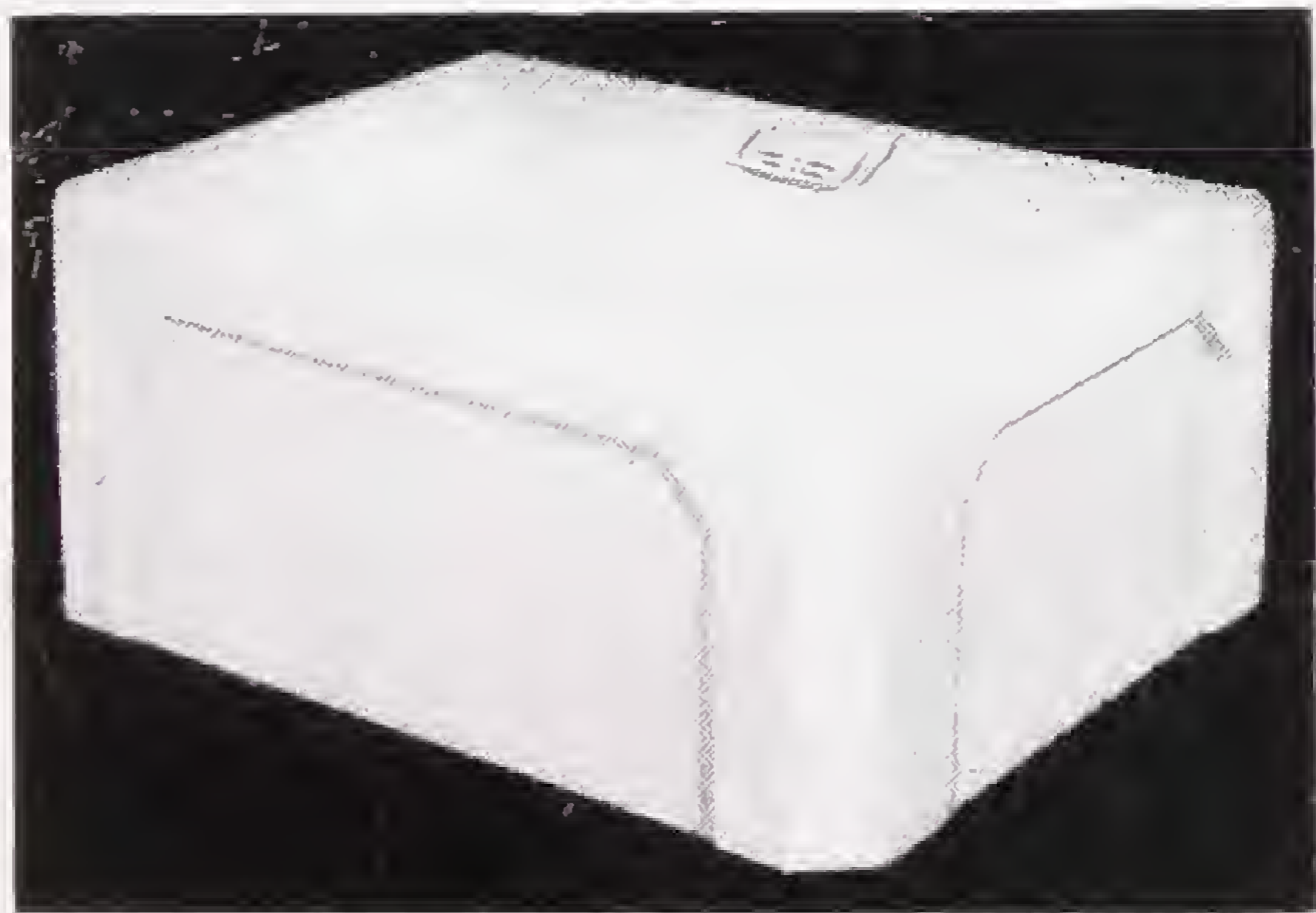

Overall Size :

24 in. \times 18 in. \times 10 in.

A stainless steel removable soap tray can be supplied which has been designed to fit into the overflow ; as shown in the illustration (Extra.)

No. B 2443 LONDON PATTERN SINK



White glazed heavy fireclay without overflow, including $\frac{1}{2}$ in. chromium-plated hot and cold bib taps, $1\frac{1}{2}$ in. waste, plug and chain, and cast-iron cantilever brackets.

Overall Sizes :

20 in. \times 16 in. \times 6 in.

24 in. \times 16 in. \times 6 in.

24 in. \times 18 in. \times 6 in.

27 in. \times 18 in. \times 6 in.

30 in. \times 18 in. \times 6 in.

30 in. \times 20 in. \times 6 in.

36 in. \times 20 in. \times 6 in.

No. B 6358 SHELF PATTERN SINK

White glazed heavy fireclay with slot overflow combined with waste in centre at back. Holed for either pillar taps or sink mixer fitting.

This is a competitively-priced sink with the advantage of a back shelf. The sides and bottom are open, giving access to the plumbing.



Overall Size:

24 in. \times $20\frac{3}{4}$ in. \times 10 in.

No. B 2459
LABORATORY SINK



White-glazed heavy fire-clay with $\frac{1}{2}$ in. rim projection all round ; open weir overflow combined with waste hole.

Overall Sizes :

24 in. \times 14 in. \times 7 in.

18 in. \times 15 in. \times 7 in.

16 in. \times 11 in. \times 6 in.

12 in. \times 10 in. \times 6 in.

Laboratory Fittings are illustrated on Pages 132/3.

No. B 6359
CLEANERS' SINK

White-glazed heavy fireclay without overflow, hardwood pad on front rim, with fittings including polished brass or chromium-plated hinged bucket grating, $\frac{1}{2}$ in. chromium-plated cold bib tap, $1\frac{1}{2}$ in. waste with grating, and painted cast-iron supporting brackets.

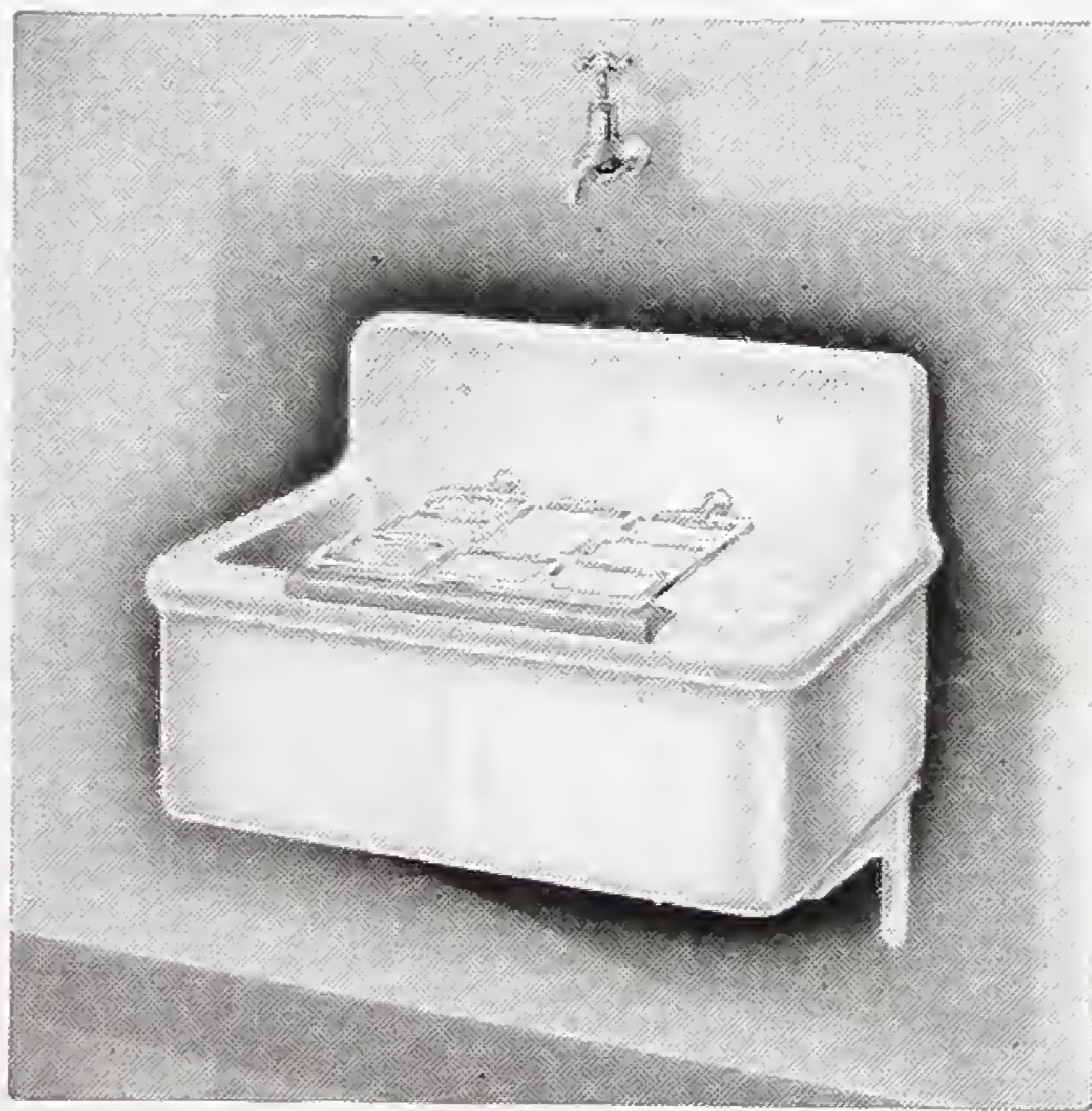

Overall Size : 18 in. \times 14 in. \times $7\frac{1}{2}$ in.



No. B 6373 HOSTESS SINK UNIT

A cast-iron sink with acid-resisting porcelain-enamelled finish available with fluted drainer on the right or left-hand side ; with or without overflow. Concealed lugs are provided on the underside of the rim for fixing wall brackets or pillar legs. Fittings include $\frac{1}{2}$ in. chromium-plated hot and cold mixer fittings with centre supply nozzle, $1\frac{1}{2}$ in. waste with plug and chain. Supplied in white, cream, or opal green.

Overall sizes : Length—3 ft. 6 in., Width— $21\frac{3}{8}$ in.

A special waste hole for use with a crumb strainer waste fitting can also be supplied (extra).

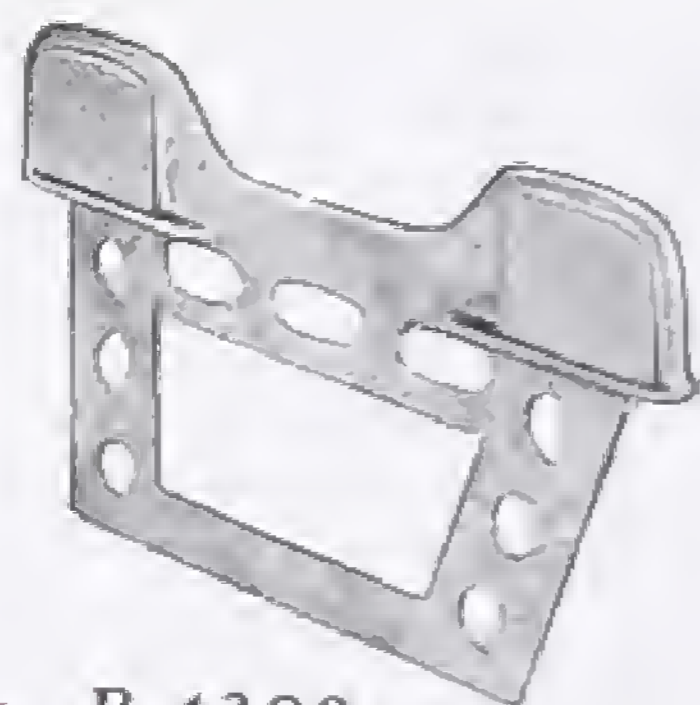

**No. B 4390
GALVANIZED WRINGER
PLATE**

For fixing between tubs. Any ordinary size of wringer can be attached

**No. B 2511
CAST-IRON
STANDARDS**

For sinks with arm to screw to wall.

Height :
20 in. or 23 in.

White
porcelain-enamelled
or
Plain-painted

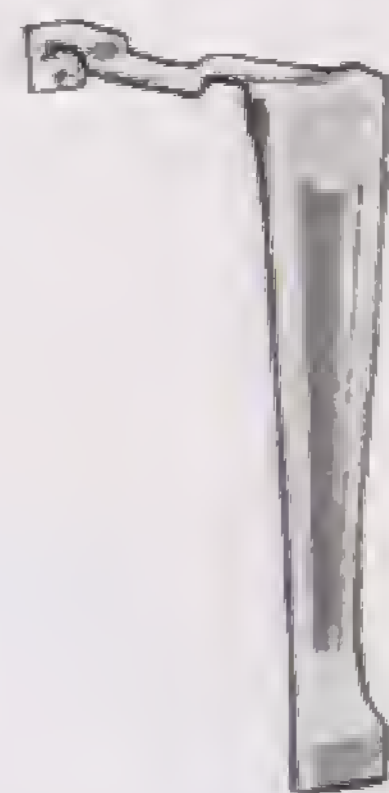

**No. B 2512
CAST-IRON
CANTILEVER BRACKETS**

Suitable for fireclay sinks and wash tubs. With tail piece for building into wall. In pairs consisting of one plain bracket and one with cut-out as illustrated. Supplied white-porcelain enamelled or plain-painted.

SINK DRAINERS

No. A 3872
SINK DRAINER

"Namel" White Vitreous Enamel. Fitted with Adjustable Under-Carriage.

Sizes :

21 x 16½ in. 24 x 16½ in.

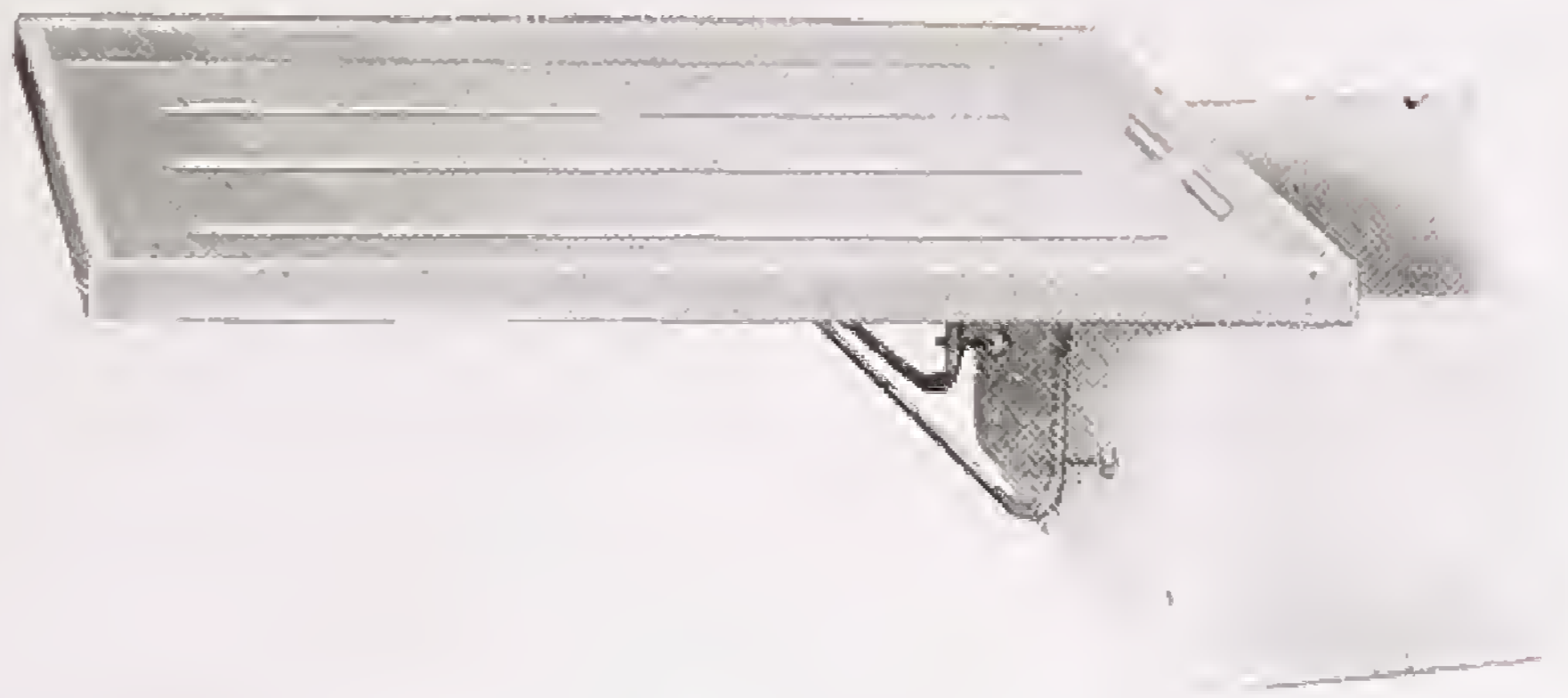

No. A 3920
SINK DRAINER

"Sphinx" White Vitreous-Enamel. Fitted with Adjustable Under-Carriage.

Sizes :

23 x 14 in. 27 x 16 in.

No. A 3922
SINK DRAINER

"Easiclene" White Vitreous-Enamel. Fitted with Adjustable Under-Carriage.

Sizes :

22 x 15 in.
24 x 16½ in.

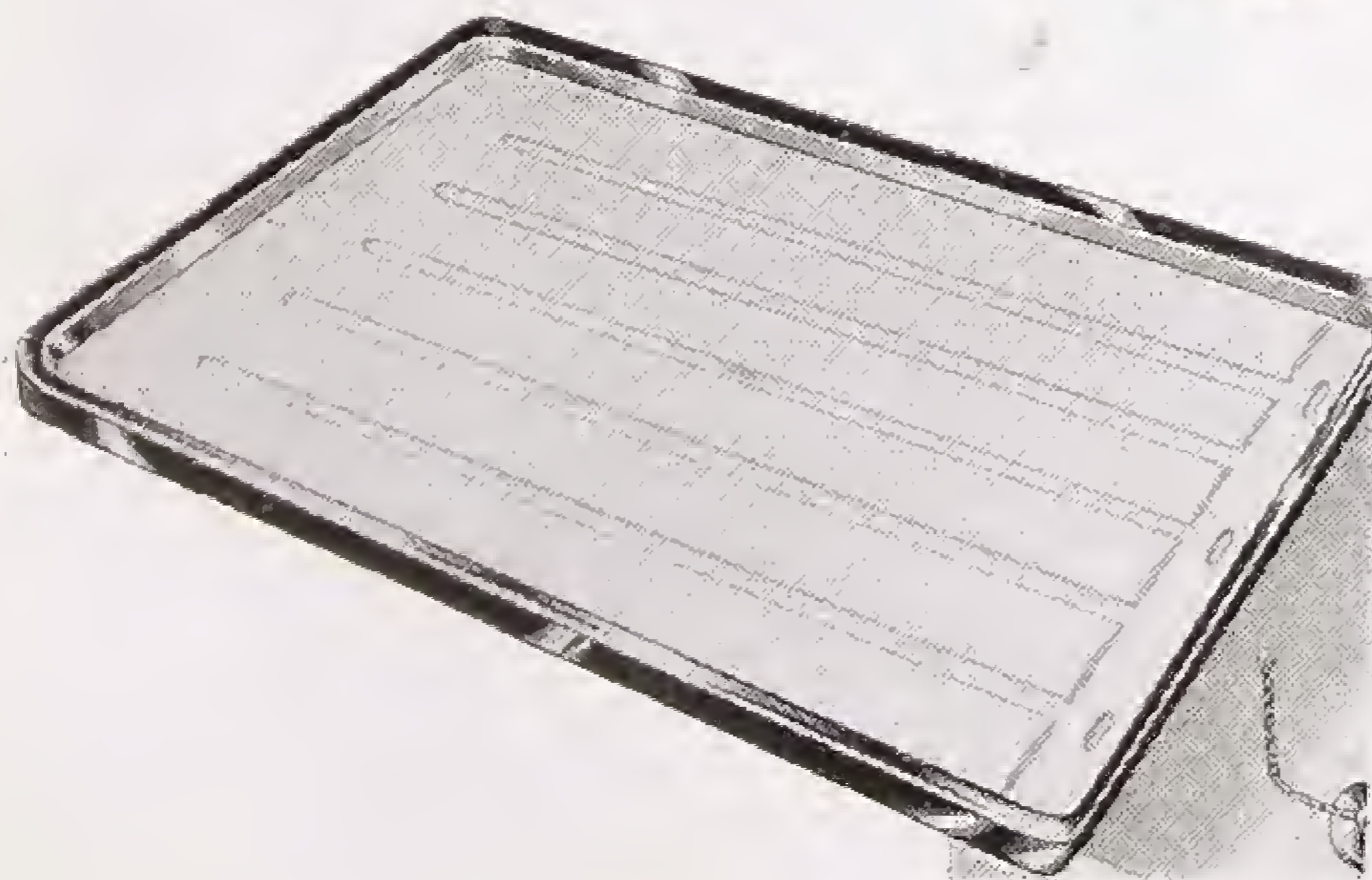

No. A 3921
SINK DRAINER

"Hartington" White Vitreous-Enamel With Adjustable Under-Carriage.

Sizes :

18 x 15 in. 22 x 15½ in.
24 x 17¼ in. 30 x 17¼ in.

No. A 3878
SINK DRAINER

"Hartington" Aluminium Alloy. Similar Construction to No. A 3921.

Sizes :

18 x 16 in. 24 x 16 in.
24 x 18 in. 27 x 18 in.
30 x 18 in. 36 x 18 in.



No. B 6255

THE UNITAS TOILET SUITE

Comprising 2, 2½ or 3-gallon cistern and cover, with special valveless siphon fittings; siphonic action pan with "P" or "S" trap, black plastic seat and cover. Pottery in best-quality white or coloured earthenware.

Height : 33 in.

Projection : 28 in.

No. B 6345

THE NEW UNIVERSIA TOILET SUITE

Comprising 2, 2½ or 3-gallon cistern and cover, with special valveless siphon fittings; straight front siphonic action pan with "P" trap, black plastic seat and cover.

Pottery in best quality white or coloured earthenware.

Height : 30 in.

Projection : 27½ in.

This suite can be supplied with a chromium-plated feed pipe to floor with control valve and chromium-plated overflow pipe to floor (extra).



The above suite is illustrated for "P" trap fixing but can be supplied with suitable bend to form an "S" trap if required.



No. B 6346

UNIT TOILET SUITE

A suite of distinctive appearance and perfect siphonic action ; comprising 2, 2½ or 3-gallon cistern and cover with special valveless siphon fittings ; siphonic action pan with "P" or "S" trap, black plastic seat and cover ; pottery in best quality white or coloured earthenware.

Height : 33½ in.

Projection : 28 in.

No. B 6347

**THE "UNITONA"
TOILET SUITE**

A boldly-designed suite, functionally similar to the above but of completely different appearance ; comprising 2, 2½ or 3-gallon cistern and cover with special valveless siphon fittings ; siphonic action pan with "P" or "S" trap, black plastic seat and cover.

Pottery in best quality white or coloured earthenware.

Height : 31½ in.

Projection : 26 in.





No. B 4239

**SILENT SIPHONIC
TOILET SUITE**

Comprising 2, 2½ or 3-gallon cistern and cover, with valveless siphon fittings and wall supports; flush bend with pressure reducing fitment, silent siphonic pan with "P" or "S" trap, black plastic seat and cover. Pottery in best quality white or coloured earthenware.

Height : 39 in.

Projection : 30½ in.

No. B 6258

**SIPHONIC
TOILET SUITE**

Comprising 2, 2½ or 3-gallon cistern and cover with 1½ in. valveless siphon fittings and wall supports and enamelled flush pipe; siphonic "P" or "S" trap pan with black plastic seat and cover. Pottery in best quality white or coloured earthenware.

Height : 41 in.

Projection : 30 in.





No. B 6275

TOILET SUITE

Comprising 2, 2½ or 3-gallon cistern and cover with 1½ in. valveless siphon fittings and wall supports, flush bend with connection, w.c. pan with "S" or "P" trap, black plastic single seat; pottery in best quality white or coloured earthenware.

Height: 41 in.

Projection: 29 in.

No. B 4348. **TOILET SUITE**

Specially designed to give the minimum projection from front to wall face.

Comprising 2 or 2½-gallon cistern and cover with 1½ in. valveless siphon fittings and wall supports, chromium-plated cranked flush bend with connection, w.c. pan with "S" or "P" trap, black plastic ring pattern seat with cover; pottery in best quality white or coloured earthenware.

Height:

2-gallon size, 39 in.

2½-gallon size, 39¾ in.

Projection: 25 in.

Also supplied with a white porcelain-enamelled cranked flushbend.





No. B 6348. TOILET SUITE

Comprising 2, 2½ or 3 gallon Torcade black highly glazed moulded composition cistern and cover with valveless siphon fittings, chromium-plated end lever and wall supports; white porcelain-enamelled flush bend with connection; white earthenware w.c. pan with P or S trap, black plastic seat and cover.

Height ... 39 in.

Projection ... 30 in.

The above toilet suite can be supplied with pottery in colours and a chromium-plated flush bend. (Extra.)

No. B 6349. TOILET SUITE WITH VICTORY VALVE

Comprising chromium-plated Victory flushing valve arranged to flush either 2, 2½ or 3 gallons, operated by lever handle, complete with chromium-plated flush bend, w.c. connection and wall clip; white earthenware w.c. pan with P or S trap; white lacquered wood ring pattern seat and cover.

Height ... 42 in.

Projection ... 26 in.

This w.c. suite can be supplied with pottery in colours and alternative types of w.c. seats to match.

Note on the installation of Flushing Valves:

It is essential that Victory Valves are connected to a separate storage tank and fed by pipe of the correct diameter to suit the head of water.

We shall always be pleased to give advice on this matter if dimensioned sketches showing proposed layouts are submitted.



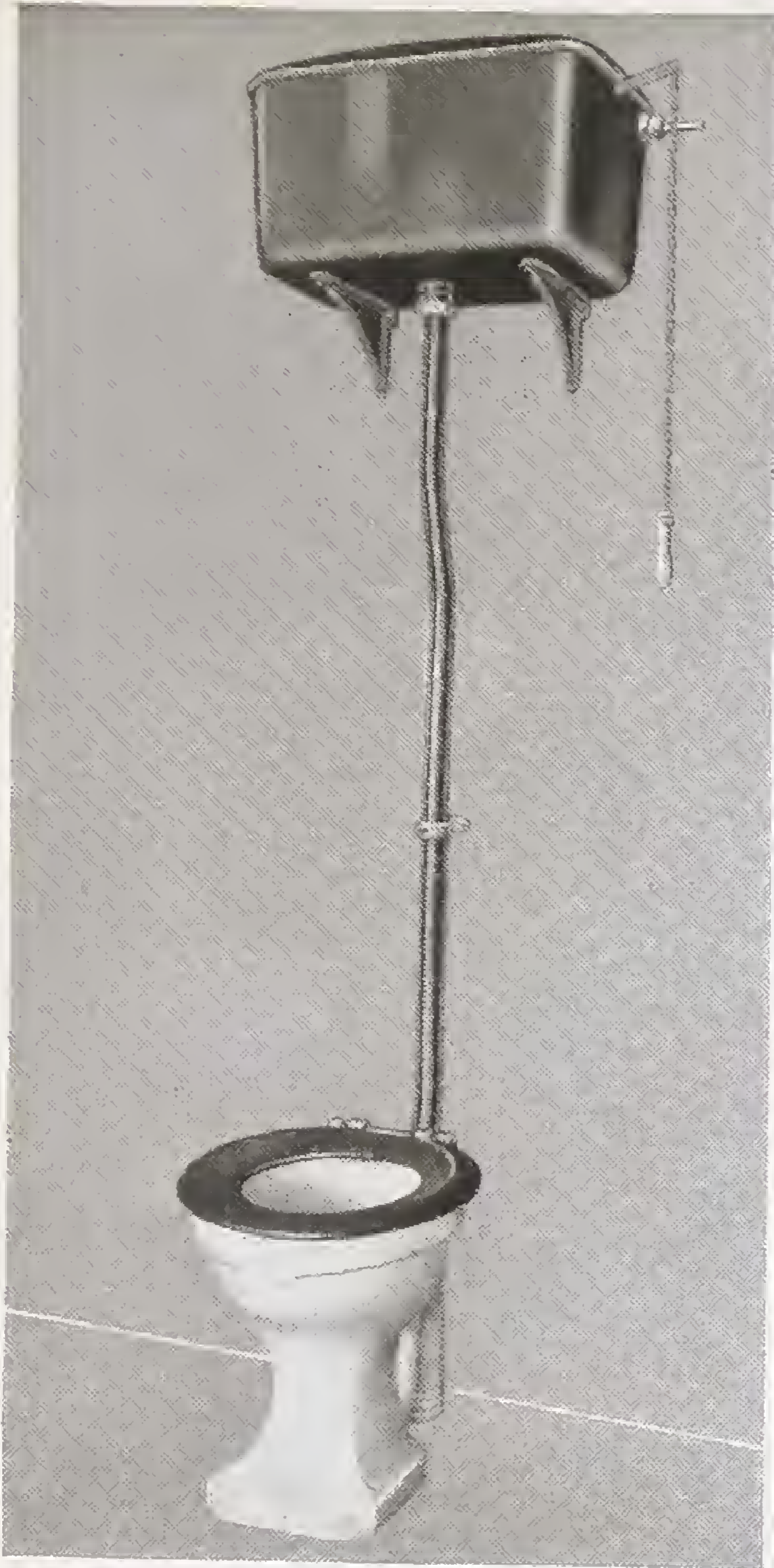

No. B 6259

**HIGH-LEVEL TOILET
SUITE**

Comprising 2, 2½ or 3-gallon black moulded composition flushing cistern and cover with 1½ in. valveless siphon fittings, galvanized chain and pull, and cast-iron supporting brackets; black plastic flush pipe with connecting cone; white earthenware washdown pan with "S" or "P" trap, black plastic single ring seat.

No. B 2390

PEDESTAL SLOP HOPPER

Ware in white-glazed heavy fireclay. Comprising pedestal slop hopper with 4 in. back and side skirtings, "S" or "P" trap, fixed hardwood pad on front. Fireclay cistern with cover, valveless siphon fittings, chain pull with ring guide and white porcelain-enamelled brackets. 1½ in. brass flush pipe and clips. Polished brass hinged bucket grating.

Also supplied with exposed brasswork chromium-plated.

Overall Size :

Hopper 18 in. × 18 in. × 18 in.





No. B 6354

SLOP HOPPER AND SINK UNIT

Ware in white-glazed heavy fireclay. Comprising pedestal slop hopper with 4 in. back and side skirtings, S or P trap and hardwood pad on front ; plain edge Belfast sink with weir overflow, plain drainer with beaded edge. Brass hinged bucket grating for hopper ; $\frac{1}{2}$ in. hot and cold bib taps with exposed unions and wall mounts ; $1\frac{1}{2}$ in. waste fitting with plug, chain and stay for sink outlet and including connecting pipe to hopper. Fireclay cistern with cover, valveless siphon fittings, chain pull and white porcelain-enamelled brackets ; $1\frac{1}{2}$ in. flush pipe and clip.

All exposed brasswork chromium-plated.

Overall Sizes :

Hopper : 18 in. \times 18 in. \times 18 in.

Sink : 24 in. \times 18 in. \times 10 in.

Drainer : 24 in. \times 18 in.

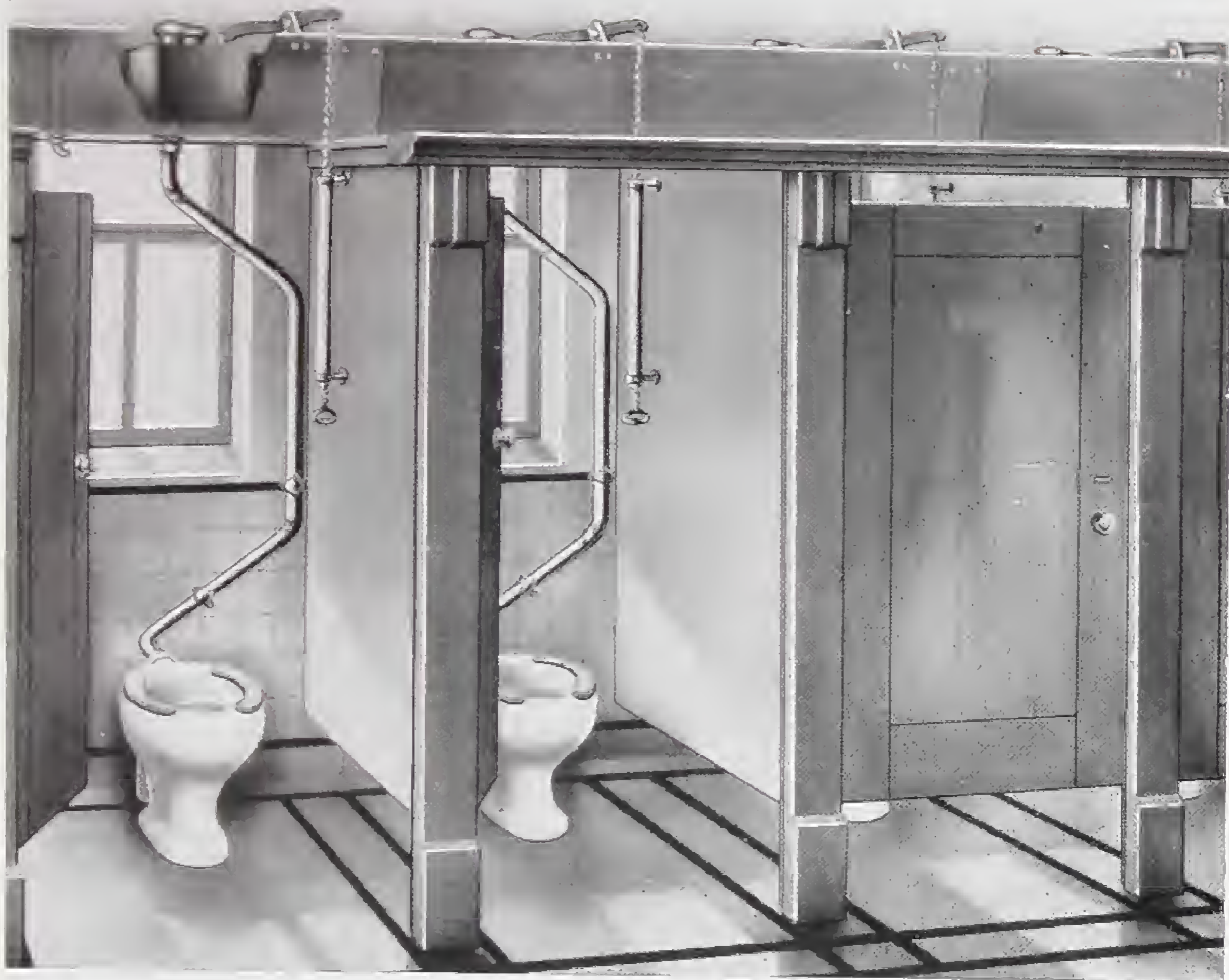

No. B 1650

**HEAVY GLAZED FIRECLAY W.C. PANS WITH
CONTINUOUS FLUSHING FEED SYSTEM**

Comprising heavy white fireclay washdown pans, 16 in. high, 45 lbs. weight with S or P traps (with or without vent as required), fixed hardwood seat pads and horizontal inlets. Galvanized steel continuous trough with 6 in. lapping pieces and stop ends bolted together, $1\frac{1}{4}$ in. rustless siphons with galvanized containers and ball valve and overflow. Strong galvanized chain pulls with stirrup handles, and galvanized cantilever brackets to support trough. Including $1\frac{1}{4}$ in. galvanized steel telescopic flush pipes approximately 5 ft. 6 in. long, with clips for back wall fixing.

Centres not exceeding 3 ft. 6 in. Flush, 2 gallons per pan.

This system has been specially designed for school and factory use, where during allotted periods the W.C.s are constantly in use and require flushing every few seconds.

NOTE.—Can be supplied to suit any centres, corner or back wall flush pipes, left or right-hand, also back wall pull, bracket or partition fixing.

When ordering, please state overall distance between walls, centres and thickness of partitions: also height to top of partition and any structural details that may be necessary.

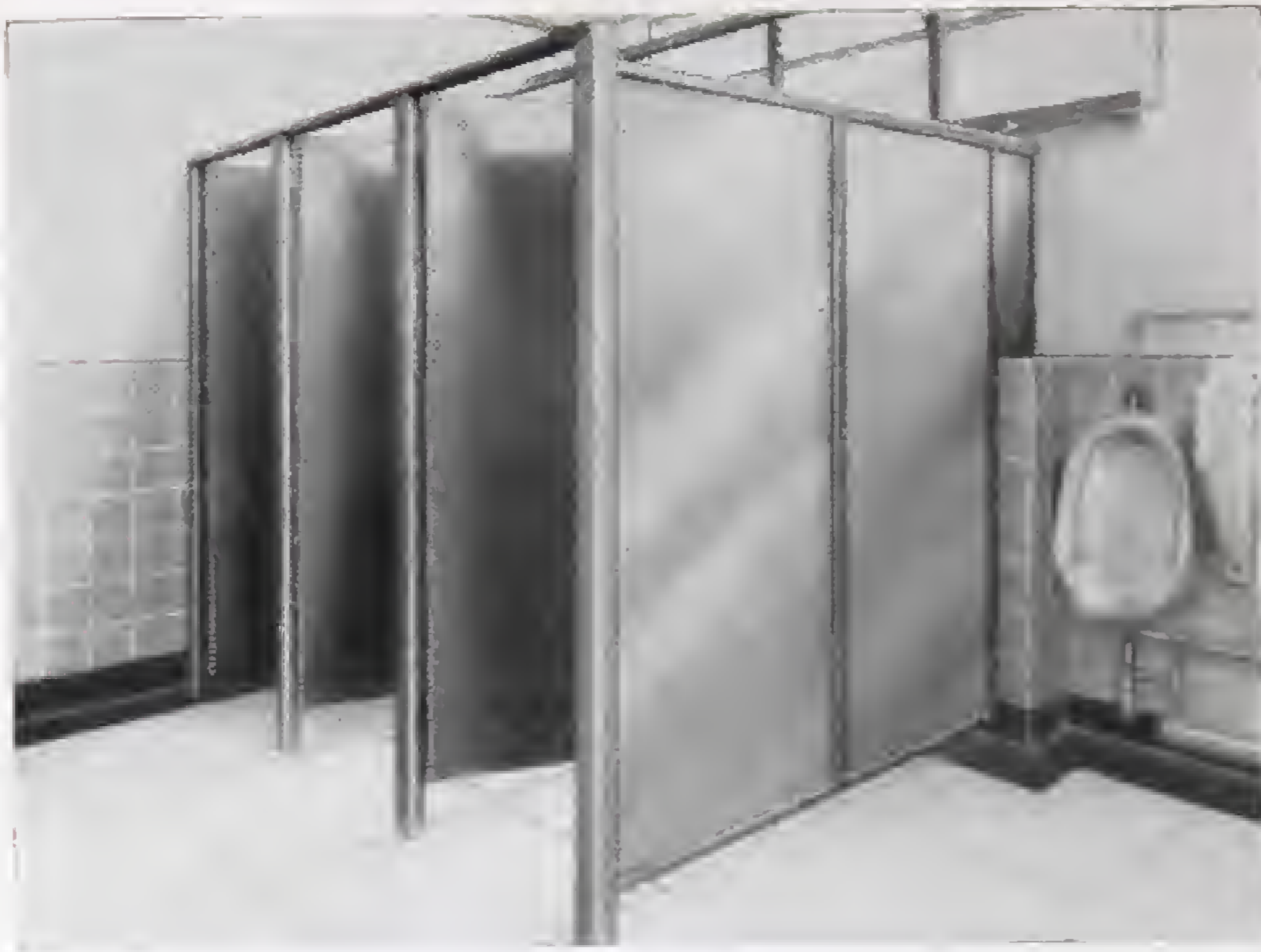

“ BEANCO ”
GLAZED
LAVATORY
DIVISIONS

The posts and rails are all made of cast-iron which, when painted, is almost rust-free.

Being heavily constructed, vibration is almost eliminated.

Twin sheets of glass sandblasted on one side are placed together, presenting a glazed external surface on each side of the divisions ; these glazed surfaces are easily washed down.

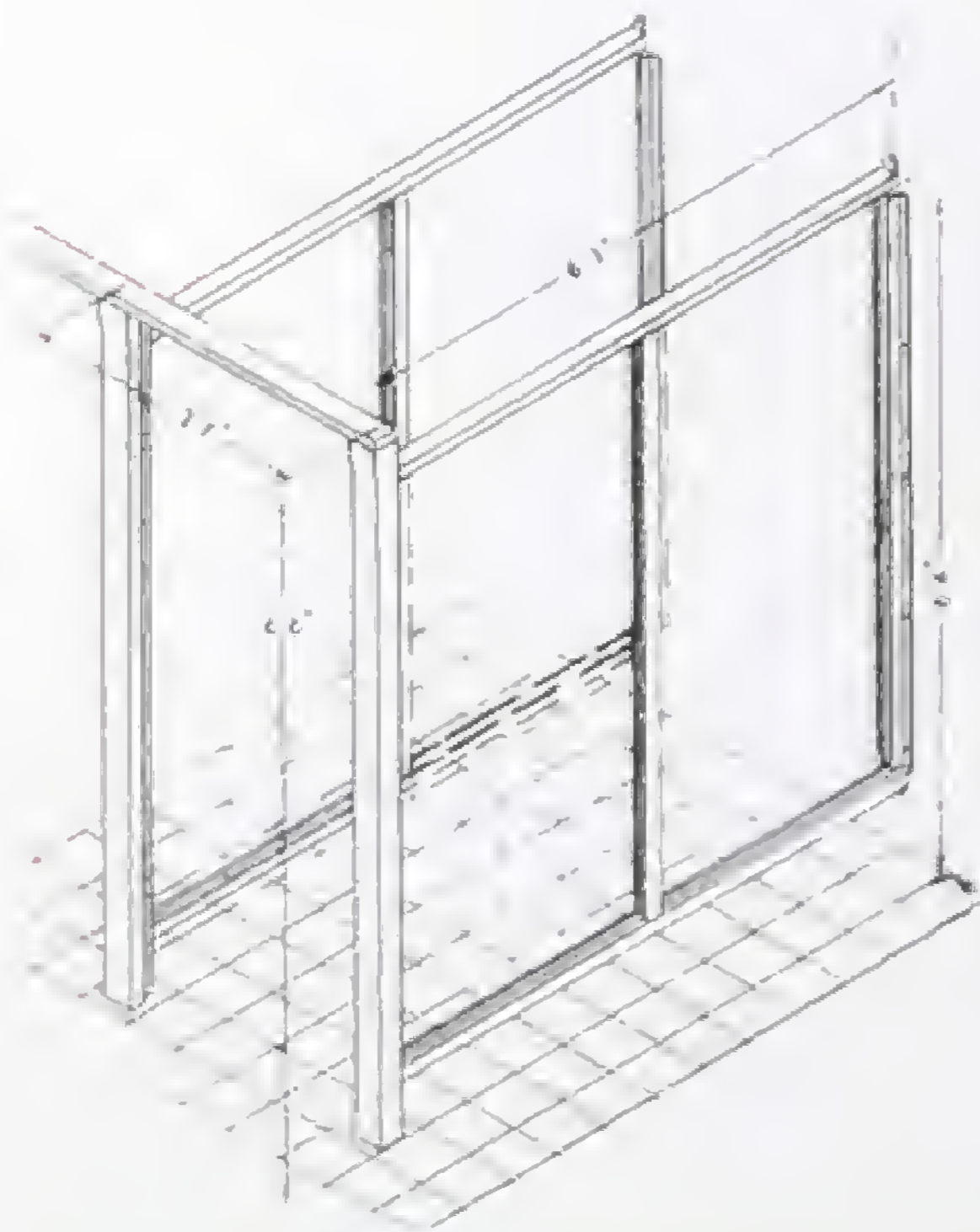

Our existing patterns can be modified to suit special circumstances, if necessary.



**“BEANCO”
GLAZED
LAVATORY
DIVISIONS**



Special features are :—

Horizontal bars along the front to prevent lateral vibration.

Special plates are fitted to accommodate toilet paper fittings.

6-in. space is left at the bottom to allow for thorough cleansing of the floor.

The divisions, being 6-ft. 6-in. minimum height ensure complete privacy.

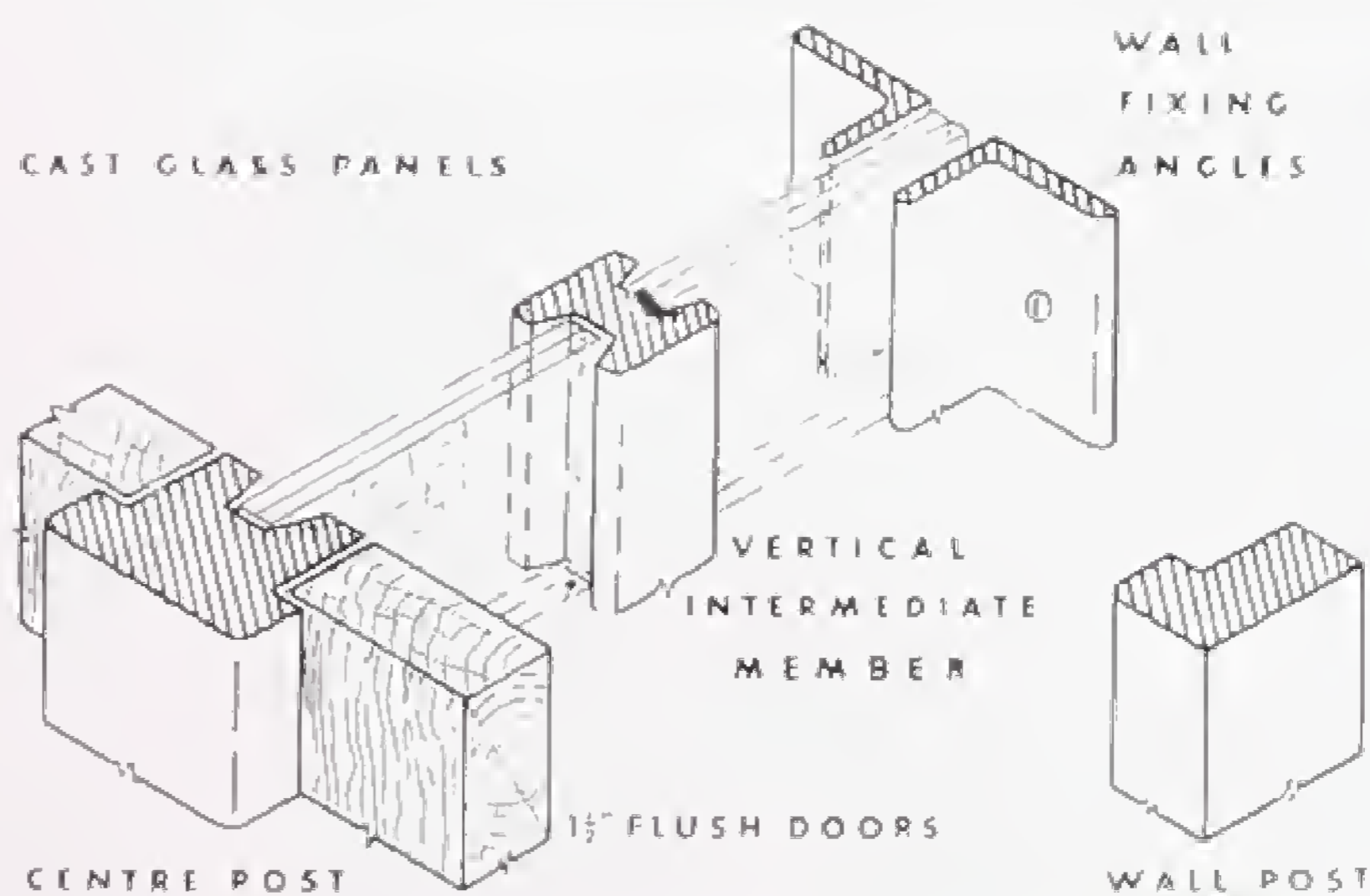
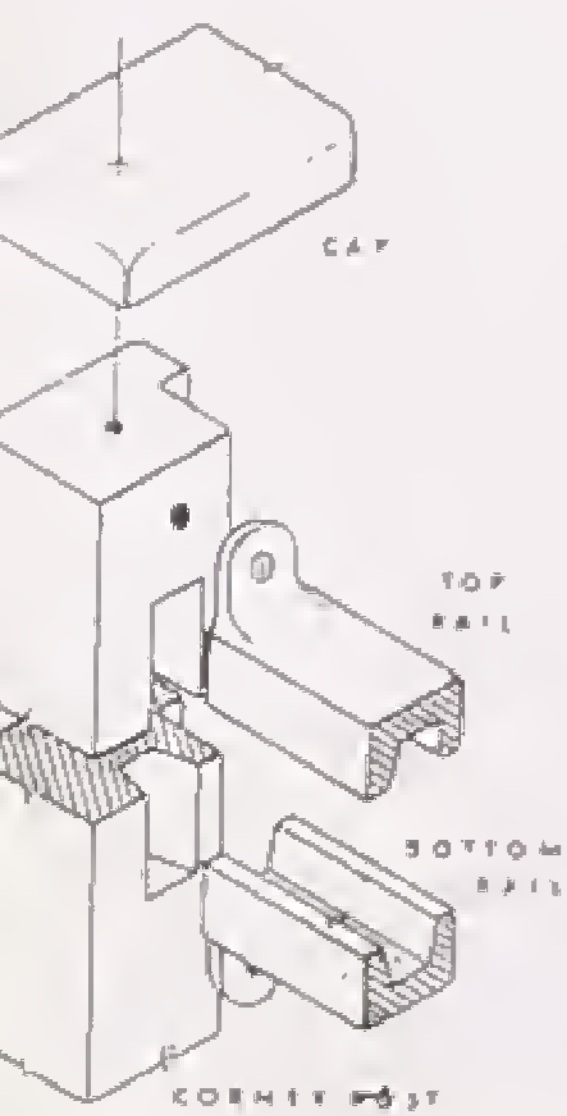



No. B 1559

PEDESTAL W.C. PAN

Best Quality White-glazed
Earthenware

Cut-away front and seat lugs.

“S” or “P” trap.

Turned “P” traps also supplied
(extra).



No. B 6350

SIPHONIC

PEDESTAL W.C. PAN

Best Quality White-glazed
Earthenware.

Straight front and seat lugs. “P”
trap.

For “S” trap fixing can be supplied
with suitable bent connection.



No. B 1561

PEDESTAL W.C. PAN

Best Quality White-glazed
Earthenware.

Full front, bottom outlet, and seat
lugs.

When ordering state if Front,
Centre, or Back Outlet required.

No. B 6351.

PEDESTAL W.C. PAN

Standard quality white-glazed heavy fireclay ; with horizontal inlet and seat lugs. "S" or "P" trap with or without anti-siphon vent ; average weight, 45 lb.

Height : 16 in.



No. B 6352.

PEDESTAL W.C. PAN

Standard quality white-glazed heavy fireclay, with horizontal inlet and fitted with plain hard-wood seat pads.

"S" or "P" trap with or without anti-siphon vent.

Height : 16 in.



No. B 6353.

SCHOOL PEDESTAL W.C. PAN

Standard quality white-glazed heavy fireclay ; with horizontal inlet, "S" or "P" trap with anti-siphon vent, and brass inspection cap. Black plastic open front single w.c. seat with moulded pillar hinges.

Height : 14 in. or 12 in.

This w.c. pan can also be supplied without the anti-siphon vent.



MONKEY PANS AND ORIENTAL TYPE CLOSETS

No. EX 4075

ORIENTAL CLOSET

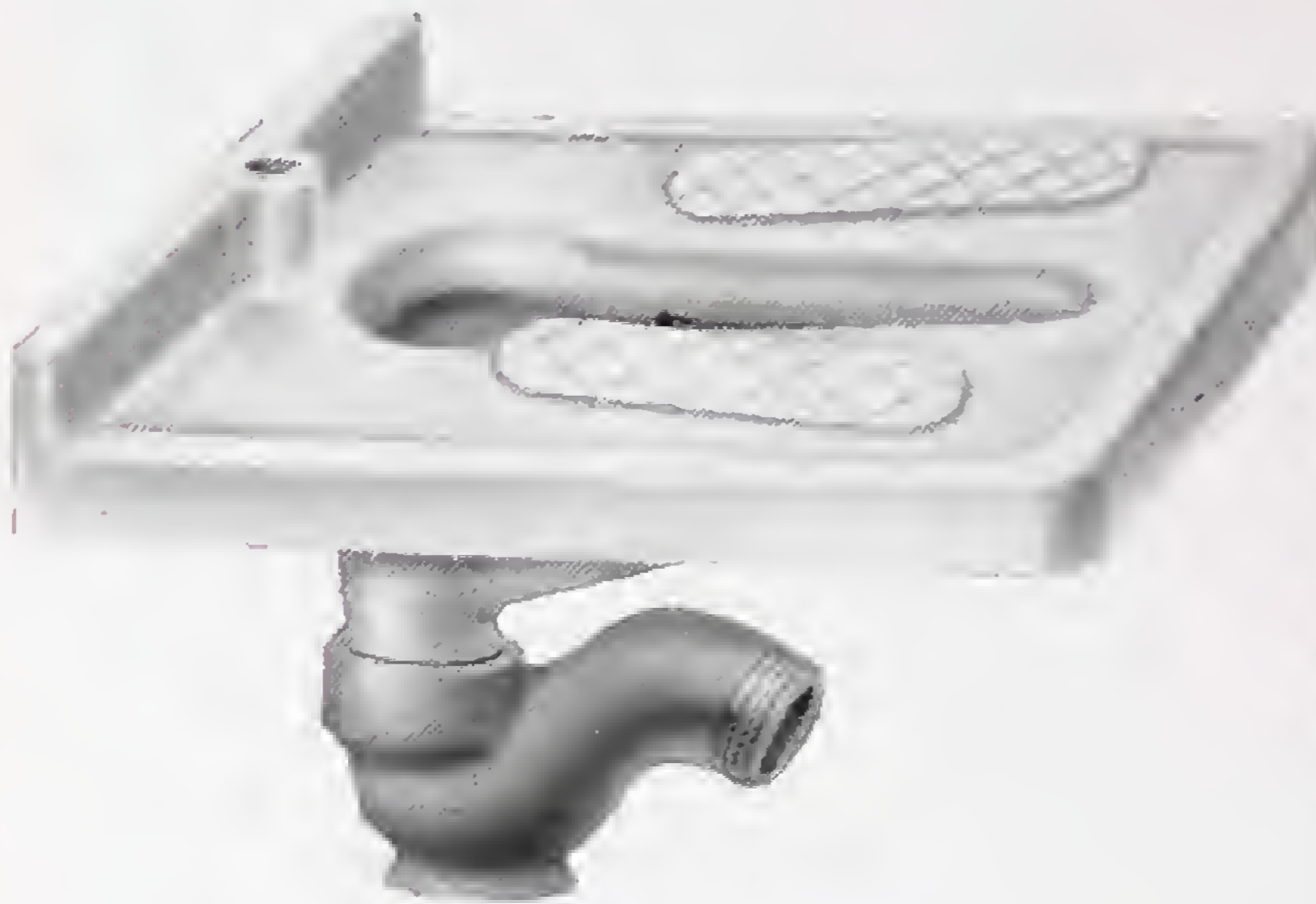

White glazed fireclay, upper with back skirting vertical inlet, pear shaped opening, integral treads and integral pan, with flushing rim; separate white glazed fireclay "P" trap 4" (10 cm) bore; overall size of upper 30" x 30" (76 cm x 76 cm) Also obtainable size 30" x 24" (76 cm x 61 cm); with "S" trap.

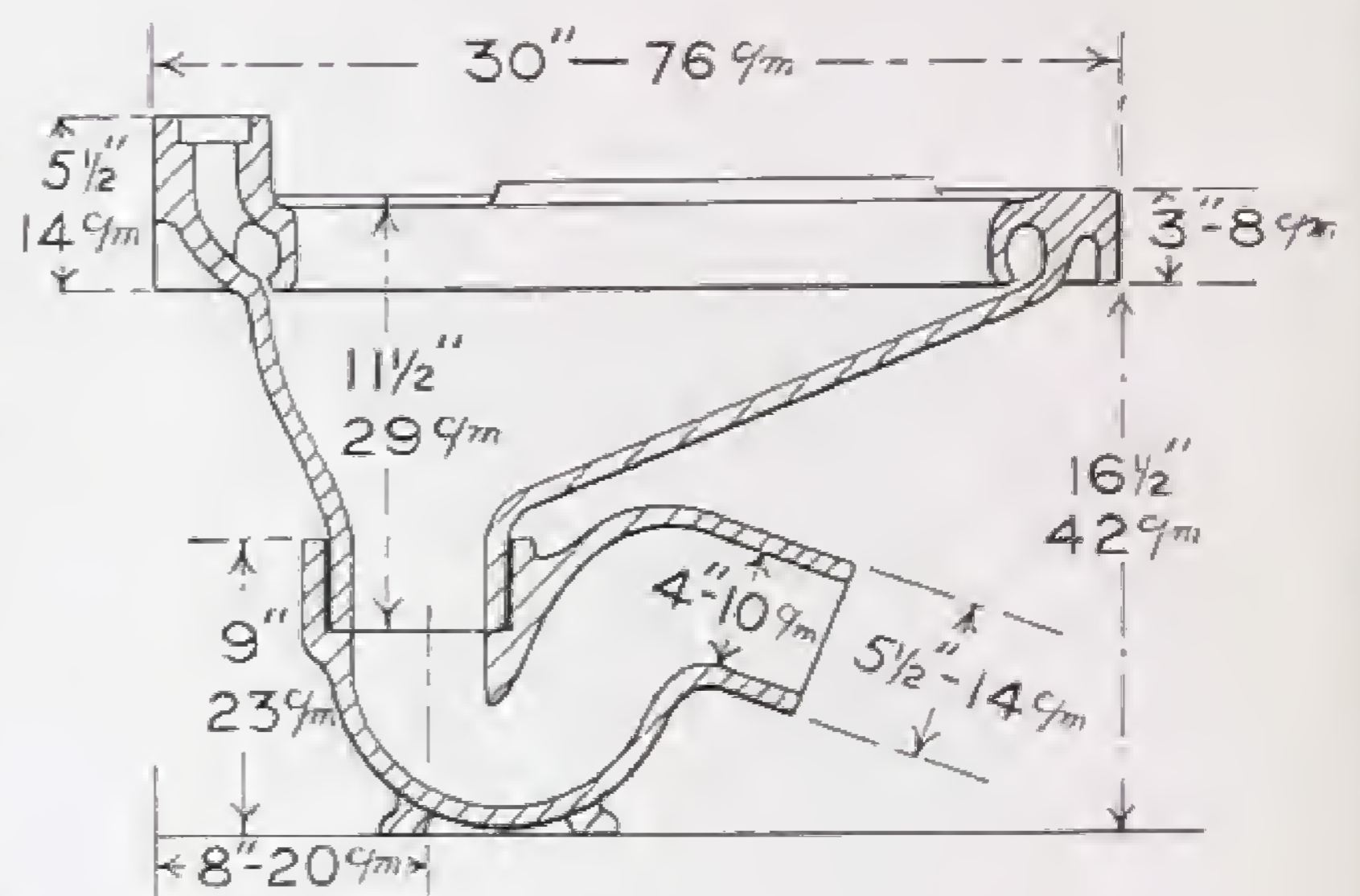
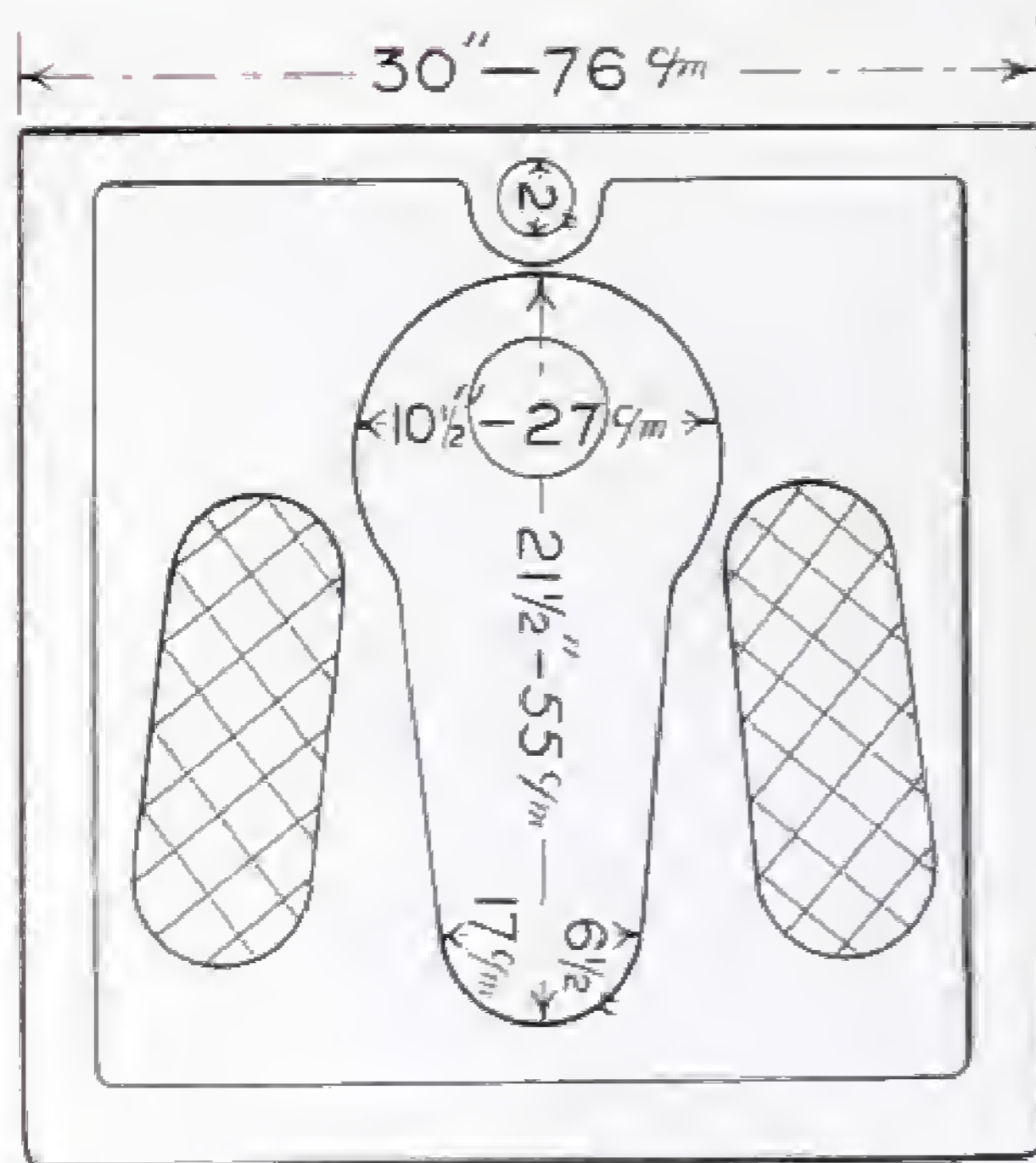

No. EX 4074

ORIENTAL CLOSET

White glazed fireclay upper with horizontal flushing inlet fan spreader and integral treads. Outlet 3 1/2" (9 cm). Bore 4 3/4" (12 cm) Outside diameter: Overall size 25" x 24" (64 cm x 61 cm). Alternatively with vertical inlet.

No. EX 4070

URINAL PLATE

White glazed fireclay urinal plate with integral treads; 20" x 14" x 2 1/2" overall (51 cm x 36 cm x 6 cm).

No. EX 4071

TREAD PLATE

White glazed fireclay closet upper with pear shaped opening and integral treads; 20" × 20" × 2½" (51 cm × 51 cm × 6 cm) overall; variations No. EX 4072 with round opening and integral treads. Also No. EX 4073 with 1¼" (3 cm) skirting and integral treads.

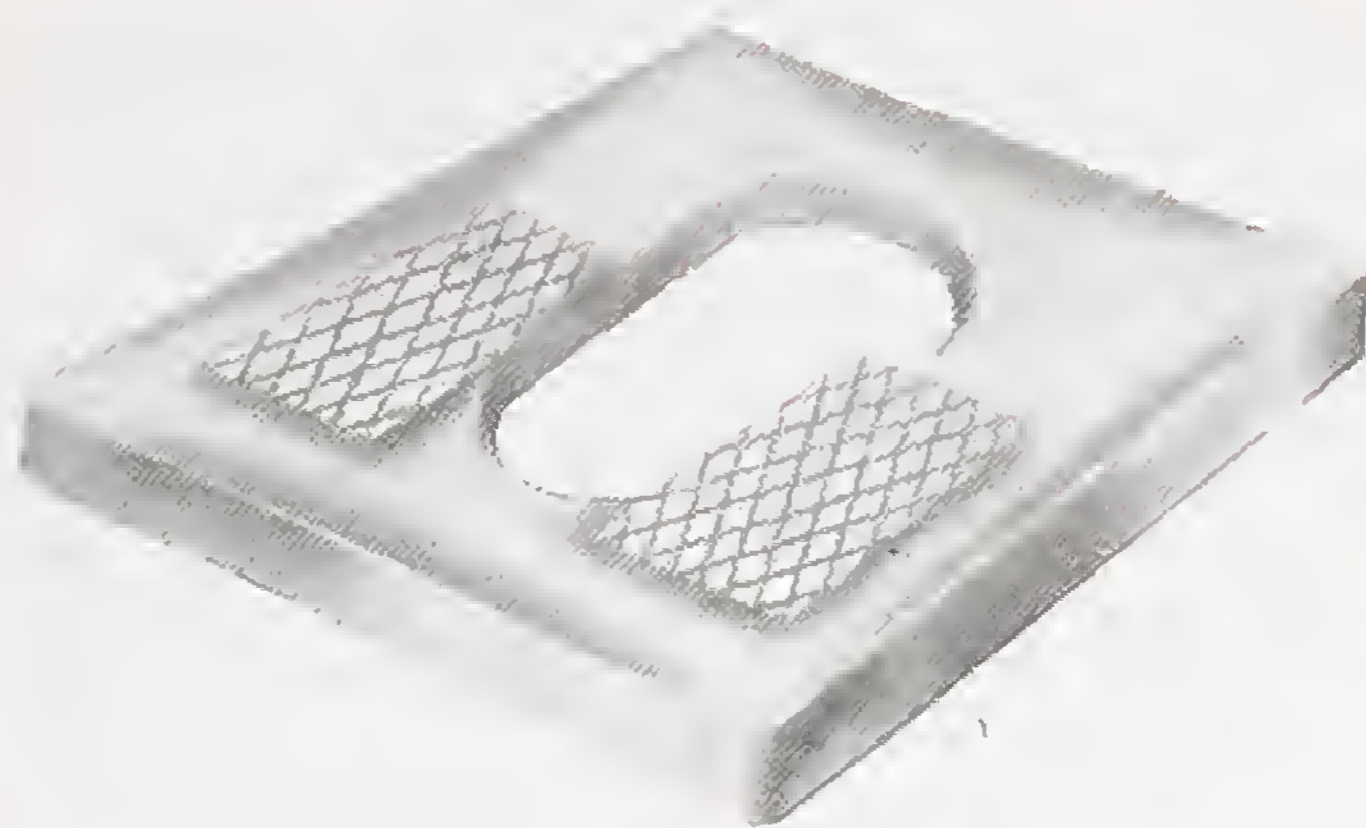

No. EX 81

**SHALLOW
MONKEY PAN**

C/W; single or double tongue. Height above flange 9½". Diameter at top 15" × 13½".



We should also be pleased to quote for:—

Salt glazed stoneware pipes and fittings etc., asbestos cement and galvanised iron sheets, flat and corrugated; cement, roofing felt and compound, damp courses, sanitary earthenware and fireclay goods, nails, tiles, cast iron baths, fishing nets, cords and lines and hooks. All kinds of Builders and Plumbers ironmongery and hardware, paints, brass coffins, shrouds and coffin furniture, flushing cisterns and flush pipes, etc. Galvanised fencing, chain link fencing, tools, hospital equipment, washing fountains, catch cork, lead sheet or pipe, rainwater goods, malleable iron fittings.

Current prices on receipt of specification.



**ELEPHANT BRAND
SQUATTING CLOSETS**

No. EX 1400

"NOTORIA" in earthenware complete with "P" or "S" trap, white or in colours. Length at top (including inlet) 18" (46 cm).

No. EX 1374



"DURONIA". Inlet at broad end and complete with "P" or "S" trap. Length at top (excluding inlet) 27" (69 cm) 25" (51 cm) 23" (58 cm) 20" (51 cm) 18" (46 cm).

No. EX 1373

"DURIA" as above but inlet at narrow end (see inset below).

No. EX 1334



"ASCANIA" Inlet at broad end and complete with "P" or "S" trap. Length at top 23" (58 cm) excluding inlet.

No. EX 1333

"ANDANIA" as above, but with inlet at narrow end (see inset below)



Inset showing inlet at narrow end, as for Nos. 1373 and 1333.

**ELEPHANT BRAND SQUATTING
CLOSETS AND FOOT TREADS**

(not fireclay) obtainable in following fadeless colours:—Ivory, cream, beige, green, jade, coral, primrose, blue, peony, black.

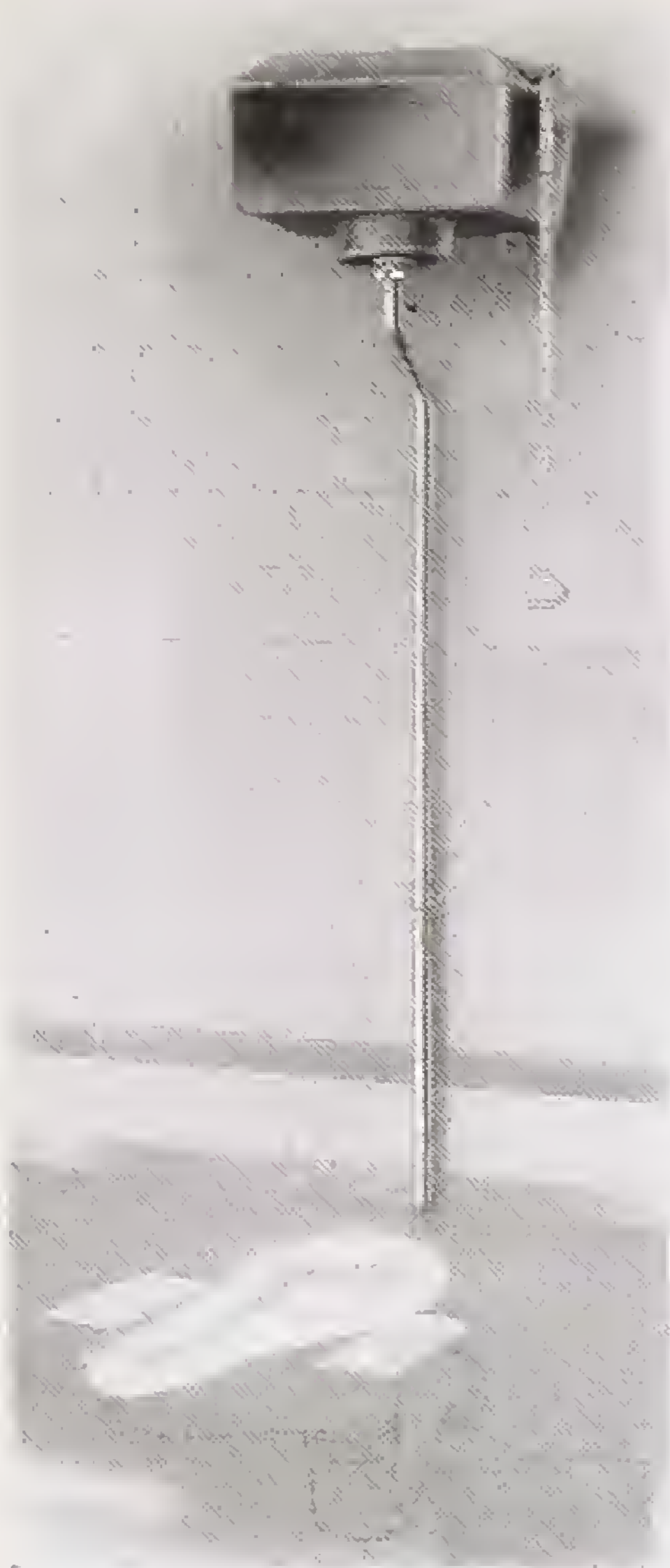

No. EX 5003

CISTERNS

“DEPENDA”. Cast iron cistern with cover, painted in and out, ball siphon $\frac{1}{2}$ " (13 mm) ball valve $\frac{3}{4}$ " (19 mm). Overflow (reversible) lever, galvanised chain and pull, lugs for screwing to wall. Capacity. 2, $2\frac{1}{2}$ or 3 gallons (9, 11 or 14 litres). Also available in galvanised steel—specify EX 5018.

No. EX 1627

FLUSH-PIPE

Galvanised steel adjustable flush-pipe, with wall clip, $1\frac{1}{4}$ " (32 mm) bore.

No. EX 1651

FLUSH-PIPE

Flushpipe as above but in black plastic material.

No. EX 1338

SQUATTING CLOSET

“VIDURIA” with integral trap at right or left hand side and vent over trap to facilitate inspection and cleaning. Length overall— $27\frac{3}{4}$ " (70 cm). Extra brass inspection cap.

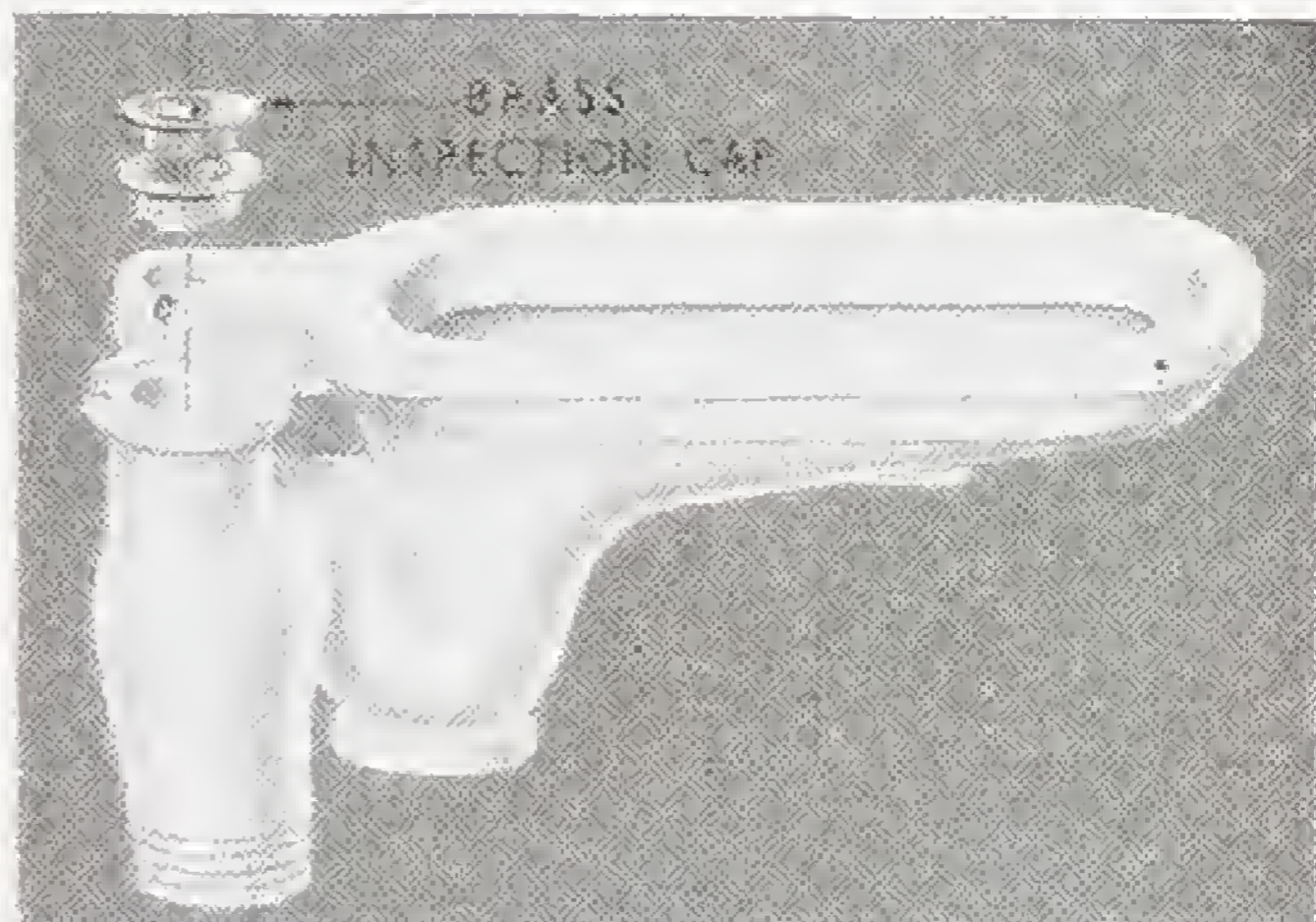

No. EX 1350

TREAD PLATES

Rectangular floor plate in white fireclay, with foot treads. No flushing rim. Overall size $30" \times 24"$ (76 cm \times 61 cm). This plate is suitable for No. EX 1334 and 23" size No. EX 1374.

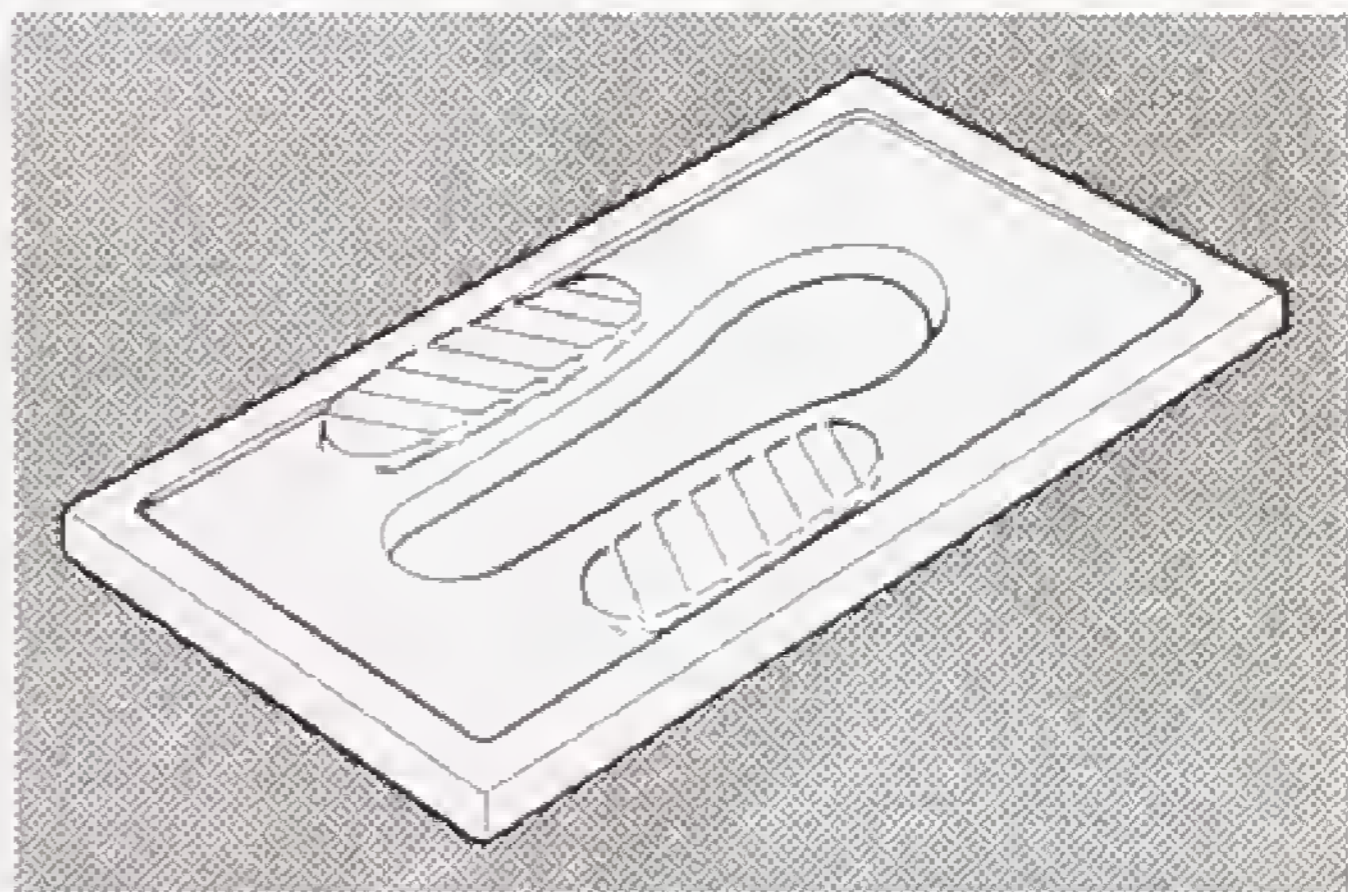

No. EX 1346

FOOT TREADS IN EARTHENWARE

$10" \times 5"$ (25 cm \times 13 cm)

When writing for prices please give full details of pattern, size, quantity and colour required.



CLOSET HOPPERS
Earthenware



No. B 1618
COTTAGE PAN

Height with trap, 15½ in.
Cane & White.



No. B 1619
LIVERPOOL PAN

Height with trap, 16½ in.
Cane & White.



No. B 1620
OVAL COTTAGE
PAN

Low—
Height with trap, 16½ in.
Tall—
Height with trap, 18 in.
Cane & White.



No. B 1623
STRAIGHT-BACK
HOPPER

With S or P Trap.

Height with trap, 16½ in.
Diameter, 15½ × 14½ in.
Outlet inside, 4½ in.

Hopper only,
Cane & White.
Traps, Cane in and out.

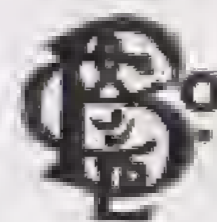

No. B 1625
S TRAP
Cane in and out.



No. B 1626
P TRAP

Cane in and out.



No. B 1621
SHORT HOPPER

Height with trap, 18 in.
Diameter, 14 in.
Cane & White.



No. B 1622
TALL HOPPER

Height with trap, 21 in.
Cane & White.



No. B 1624
TALL HOPPER

Height with trap, 21 in.
Cane & White.

Special Prices for large quantities. Any Pattern supplied with or without Trap.

SOIL PIPE FITTINGS, Etc.

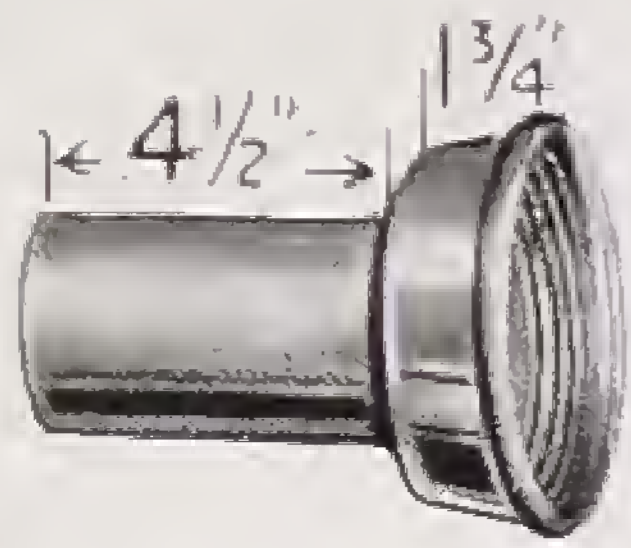

No. B 2956
**CONNECTING
SOCKET**

Cast Lead,
Iron-lined.

Straight.

Size of Socket at
smallest part :

4 1/4 4 7/8 5 5 3/8 5 3/4 in.

Size of Pipe :

3 1/2 and 4 in.

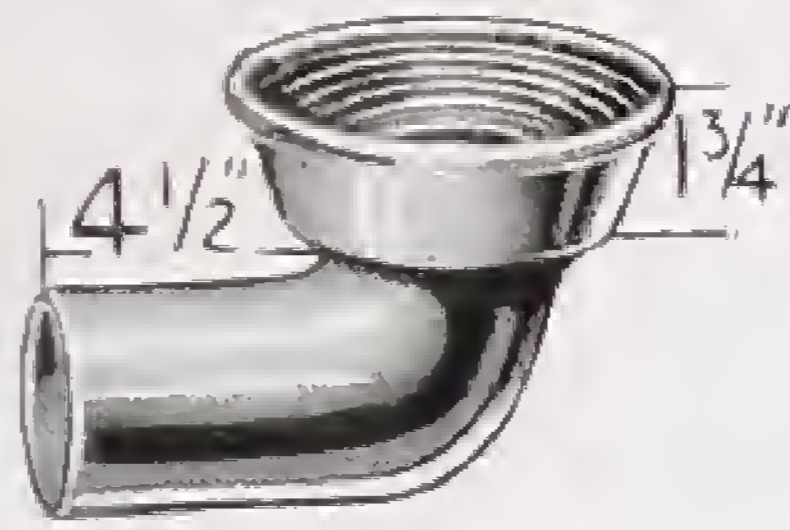

No. B 2957
**CONNECTING
SOCKET**

Cast Lead,
Iron-lined.

With bent Tail in 6 lb.
and 8 lb. Lead.

Size of Socket at smallest
part : 4 1/4 4 7/8 5 5 3/8 5 3/4 in.

Bend : 3 1/2 and 4 in.



No. B 2962
**LEAD FUNNEL
for GUTTERS**

1 3/4-in. dia.	...	4-in. long
2-in. "	...	4 1/2-in. "
2 1/4-in. "	...	4 3/4-in. "
2 1/2-in. "	...	4 1/2-in. "
2 3/4-in. "	...	4 3/4-in. "
3-in. "	...	5-in. "
3 1/4-in. "	...	5-in. "



No. RW 2965
TAYLOR'S JUNCTION
(cast-iron)

3 1/2 or 4 in. 3/16-in. Metal

Illustration above shows the various angles
at which the pipe may be laid to junction.

No. B 2970
**SOCKET, BEND,
and SLEEVE**

Hard metal Socket
burned on to solid-drawn
lead bend, with brass
sleeve fitted at other end.
Dia. of Bend : 3 1/2 or 4 in.

When ordering please give
exact length at A and B
and size of socket.

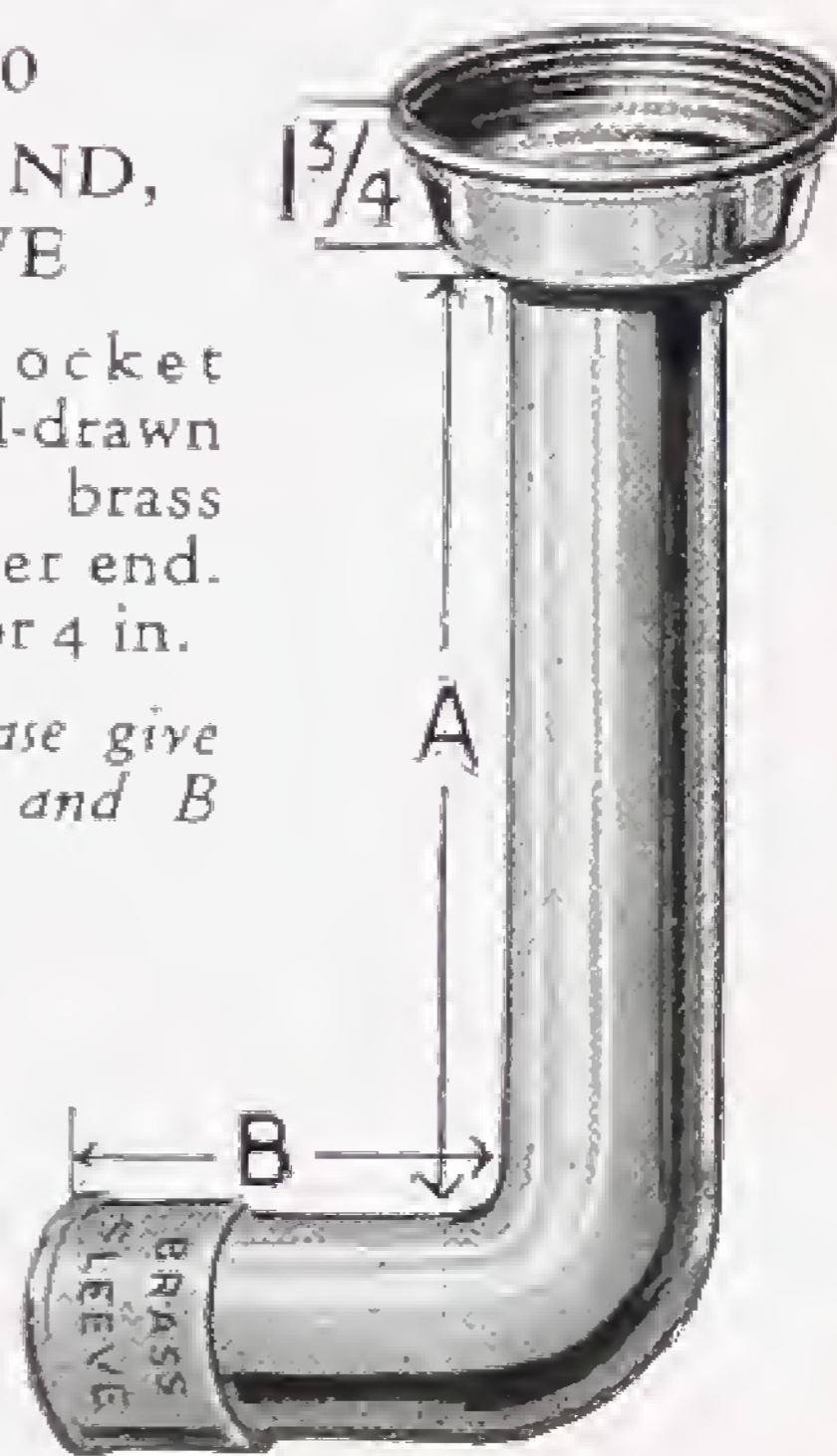

No. B 1709
**CAST-BRASS
SOCKET BEND**

For Siphonic W.C.s
Socket 4 3/4 in. I/D.
Outlet 3 1/2 in. O/D.



No. B 2971
**RIGIDA
HARD METAL
CONNECTING
SOCKET**

3 3/8, 4 1/4, 4 7/8, 5, 5 3/8, 5 3/4 and
6 3/8-in. inside diameter at
smallest part.

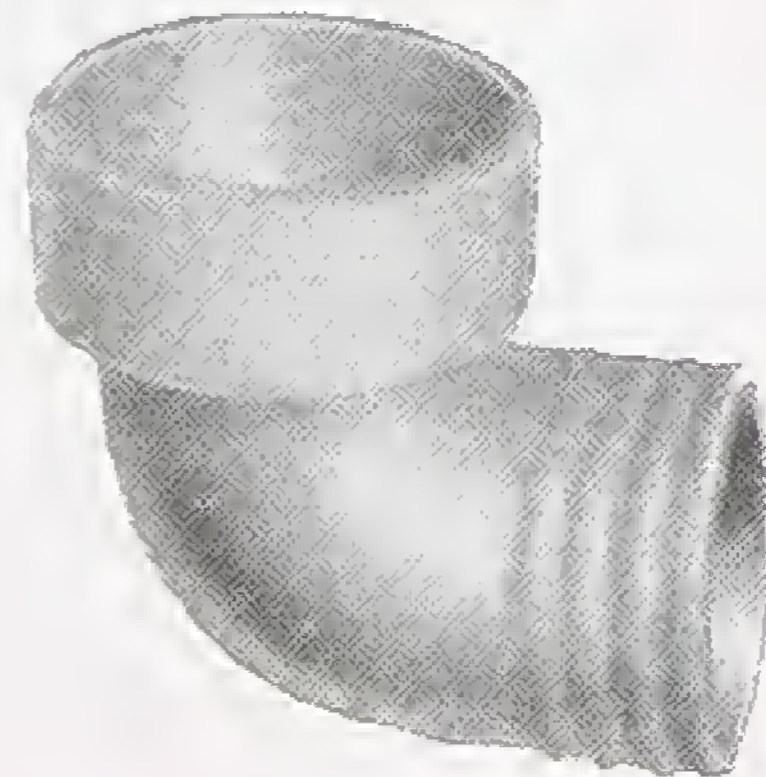

No. B 1710
**POTTERY SOCKET
BEND**

For Siphonic W.C.s
Socket 4 3/4 in. I/D.
Outlet 3 1/2 in. I/D.

SOIL PIPE FERRULES

No. B 2950 CAST-BRASS

No. B 2952 SOLID DRAWN BRASS

Bore	Length
4 1/4 in. ...	5 in.
3 3/4 " ...	5 "
3 1/4 " ...	5 "
2 3/4 " ...	4 "
2 1/4 " ...	4 1/4 "
1 3/4 " ...	4 "

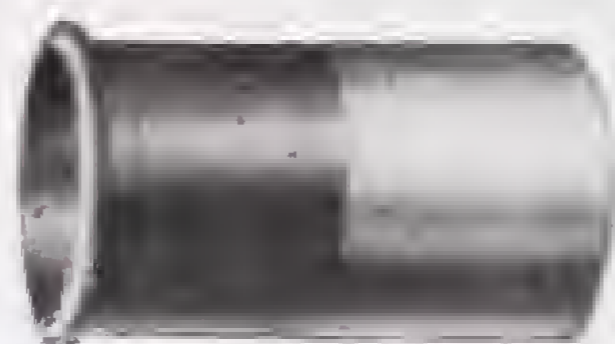

Bore	Length
4 1/4 in. ...	5 in.
3 3/4 " ...	4 1/2 "
3 1/4 " ...	4 "
2 3/4 " ...	3 3/4 "
2 1/4 " ...	3 1/4 "
1 3/4 " ...	3 1/4 "

SOIL PIPE SOCKETS

No. B 2951 CAST-BRASS

No. B 2953 SOLID DRAWN BRASS

5 3/4 x 4 1/2 in.
5 3/8 x 4 1/2 "
5 1/4 x 4 1/4 "
5 1/4 x 3 3/4 "
5 x 4 1/4 "
5 x 3 3/4 "
4 1/2 x 3 3/4 "
3 3/4 x 2 3/4 "
3 x 2 "



5 3/4 x 4 1/2 in.
5 3/8 x 4 1/2 "
5 1/4 x 4 1/4 "
5 1/4 x 3 3/4 "
5 x 4 1/4 "
5 x 3 3/4 "
4 1/2 x 3 3/4 "
3 x 2 3/4 "
3 x 2 "

W.C. SEATS



No. B 1706 PLASTIC OPEN FRONT W.C. SEAT

Single type with moulded non-ferrous pillars; supplied in black, white, or colours.



No. B 1707 PLASTIC "CONTRACT" W.C. SEAT
Moulded pillars and cadmium-plated screws. Supplied in black only. Specially introduced for Housing Schemes. Also supplied with cover (extra).



No. B 1704. OVAL RING W.C. SEAT WITH COVER

Seamless sheet covered, supplied in Mother-of-Pearl Marbled Colours. With heavy adjustable pillar hinges.



No. B 1708 PLASTIC W.C. SEAT BSS 1254 PATTERN WITH COVER

With moulded non-ferrous pillars; supplied in black, white, or colours. Also supplied without cover. A de Luxe quality seat which will enhance the appearance of any bathroom.

W.C. SEATS

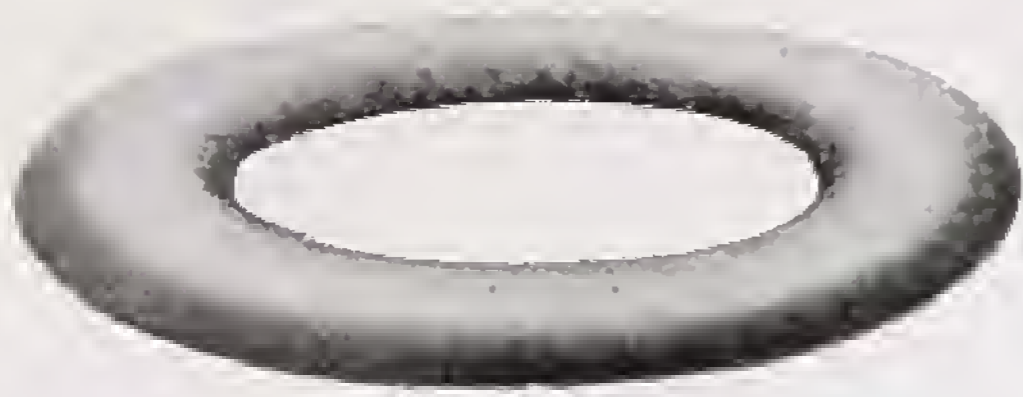

No. B 1667
OVAL RING W.C. SEAT



No. B 1668
OVAL RING W.C. SEAT
WITH COVER
and chromium-plated pillar hinges.



No. B 1673
EXTENSION W.C. SEAT

Finest quality timber.
Fitted with solid brass hinges.



No. B 1674
EXTENSION W.C. SEAT
WITH COVER
Finest quality timber.
Fitted with solid brass hinges.



No. B 1700
EXTENSION W.C. SEAT
Competitive type for housing schemes.



No. B 1702
EXTENSION W.C. SEAT
WITH COVER
Competitive type for housing schemes.



No. B 1676
AUTOMATIC or
SELF-RAISING W.C. SEAT
With solid brass hinges.



No. B 1703
SHEFFIELD TYPE W.C. SEAT
Fitted with bar hinge.
With or without iron strengthening
plates on underside of seat.

The above W.C. Seats are supplied in plain hardwood, hardwood stained mahogany colour or genuine mahogany.

Thicknesses available are 1 in. and 1½ in., with the exception of B 1676 which is only made 1½ in. thick.

Open front W.C. Seats similar to the above can also be supplied.

W.C. SEAT FITTINGS



No. B 1691
INDIA-RUBBER
BUFFER
With brass or
chromium-plated plate.

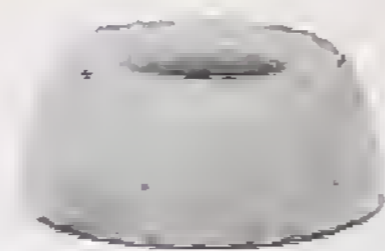

No. B 1692
INDIA-RUBBER
BUFFER



No. B 1693
PIN BUFFER

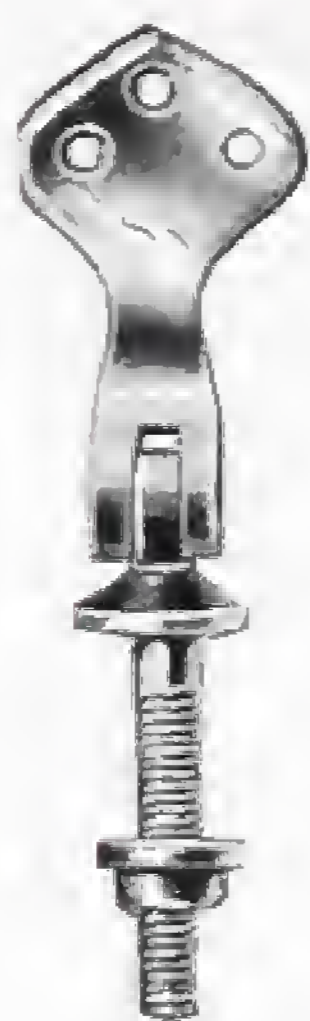

No. B 1686
CAST BRASS
HINGE
For ring pattern seats.
Polished brass, or
Chromium-plated.



No. B 1687
MALLEABLE IRON
GALVANIZED
HINGE
For ring pattern seats.



No. B 1695
CAST BRASS
HINGE
For double ring pattern
seats.
Polished brass, or
Chromium-plated.



No. B 1684
STAMPED BRASS
HINGE
For double seats.
Polished, or
Chromium-plated.



No. B 1694
SOLID BRASS
ROUND-HEAD
SEAT BOLT
AND NUT
3 x 1/4 4 x 1/4 in.
As above,
chromium-plated heads.
3 x 1/4 4 x 1/4 in.



No. B 1690
COUNTERSUNK
FLAT-HEAD SOLID
BRASS SEAT BOLT
AND NUT
3 x 1/4 4 x 1/4 in.
As above,
chromium-plated heads.
3 x 1/4 4 x 1/4 in.

No. B 1683
Similar pattern for
single seats.

THE ELSAN SYSTEM OF CHEMICAL SANITATION



No. B 4245
"ELSAN NON-SPILL"

MODEL C.V.

For Caravan, Yacht or Camp. For use as a permanent fixture or portable unit. Max. dimensions 18 in. high x 14½ in. x 15½ in. Bakelite seat, Vitreous-enamelled sewage container and aluminium guard and cover.

No. B 4244

"ELSAN" MODEL

17 in. high, 17 in. diam. Bakelite seat and lid. Urinal guard, Vitreous enamelled sewage container. Complete with vent piping.

No. B 4243

"ELSAN" MODEL

Smaller capacity. 16¾ in. high, 14 in. diam. Bakelite seat and lid. Urinal guard, Galvanised sewage container. Complete with vent piping.

ELSAN LEAFLET, GIVING FULL DETAILS OF ALL MODELS, ON REQUEST

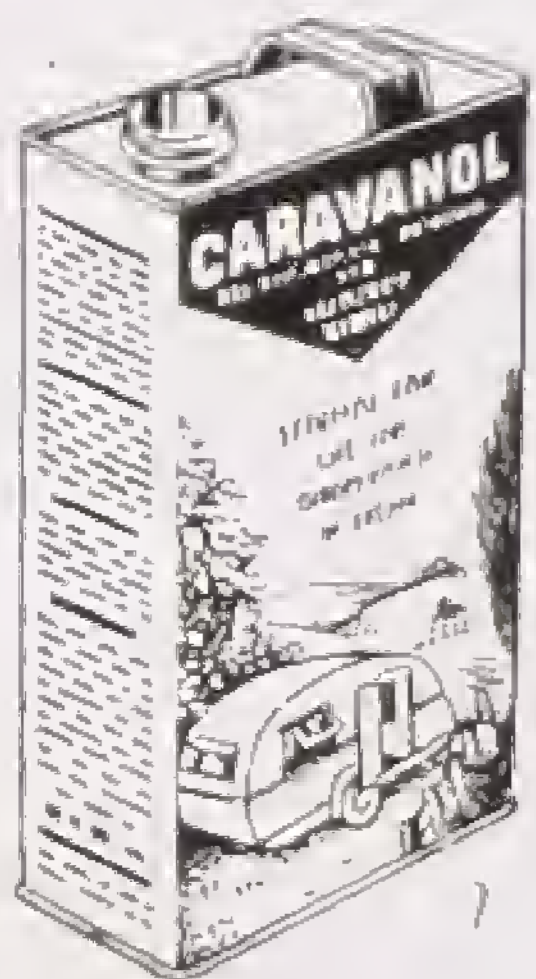

"CARAVANOL"

Specially for Elsan Closets installed in Caravans and confined spaces, highly concentrated. One Gallon Tins.

6 charges.

"ELSANOL" CHEMICAL

A powerful germicide and deodoriser, rendering sewage innocuous. Economical and safe. One Gallon Tins.

8 charges.





No. B 2000

SINGLE STALL
FLAT BACK URINAL

In WHITE GLAZED
FIRECLAY

3 ft. 6 in. high, 24 in. wide with
integral channel and 6 in. fluted
tread.

Fireclay automatic cistern with
copper siphon and white porce-
lain enamelled brackets. Gal-
vanised iron, polished copper or
chromium plated pipe and
spreader. Polished or chromium
plated gun metal domed outlet
grating with screwed tail and
locknut.

No. B 2002



SINGLE STALL
ANGULAR URINAL

In WHITE GLAZED
FIRECLAY

3 ft. 6 in. high, 3 ft. 2 in. wide
overall with integral channel
and 6 in. fluted tread.

Fireclay angular automatic
cistern with copper siphon and
white porcelain enamelled
brackets. Galvanised iron,
polished copper or chromium
plated pipe and spreader.
Polished or chromium plated
gun metal domed outlet grating
with screwed tail and locknut.





No. B 2012 URINAL RANGE

In WHITE GLAZED FIRECLAY

Comprising stalls 3 ft. 6 in. high, with integral channel, 3 in. divisions and 6 in. fluted treads.

Fireclay automatic cistern with copper siphon and white porcelain-enamelled brackets. Galvanised iron, polished copper or chromium-plated pipes and spreaders. Gun metal domed outlet grating with screwed tail and locknut.

Width of Stalls, 24 in. or 21 in.

When ordering, please state if outlet is required right-hand, left-hand, or in centre.



No. B 2024 SLAB URINAL RANGE

In WHITE GLAZED FIRECLAY

Comprising sloping back slabs 3 ft. 6 in. high, butt joints, loose return ends and divisions, block floor channel 6 in. wide inside.

Fireclay automatic cistern with copper siphon and white porcelain-enamelled brackets. Polished copper or chromium-plated down pipe with perforated horizontal pipes and clips. Polished or chromium-plated gunmetal domed outlet grating with screwed tail and locknut.

Supplied with 24×9 in. or 30×9 in. divisions.

Prices will be quoted for larger ranges on receipt of specification.



No. B 2018 SLAB URINAL RANGE

In WHITE GLAZED FIRECLAY

Comprising sloping back slabs 3 ft. 6 in. high, with integral return ends 12 in. projection and block floor channel 6 in. wide inside.

Fireclay automatic cistern with copper siphon and white porcelain-enamelled brackets. Polished copper or chromium-plated down pipe with perforated horizontal pipes and clips. Polished or chromium-plated gun metal domed outlet grating and screwed tail and locknut.

Note : One outlet grating is supplied and charged for each 12-ft. run or part thereof.



No. B 2019 URINAL RANGE

IN WHITE GLAZED VITREOUS CHINA

Comprising stalls with integral flushing chamber and lipped base, each 3 ft. 2 in. high and 1 ft. 6 in. wide ; outlet strainer to each stall with china dome and connection for 2 in. lead pipe ; automatic flushing tank in white vitreous china with regulating supply tap and semi-concealed brackets ; flushpipes with wall clips, fittings chromium-plated ; projection from wall to front of lip, 1 ft. 4 in.

WALL URINALS

BEST WHITE-GLAZED EARTHENWARE

No. B 2052 FLAT BACK

LIPPED URINAL

With Flushing Rim and Secret overflow

<i>Height</i>		<i>Diameter</i>
20 in.	...	18 in. × 14 in.
18½ in.	...	15 in. × 12 in.
17 in.	...	14 in. × 11 in.



No. B 2050 FLAT BACK URINAL

With Flushing Rim and Secret overflow

<i>Height</i>		<i>Diameter</i>
20 in.	...	18 in. × 9½ in.
18½ in.	...	15 in. × 9 in.
17 in.	...	14 in. × 8 in.
15½ in.	...	12 in. × 6½ in.

No. B 2054 ANGULAR URINAL

With Flushing Rim and Secret overflow

<i>Height</i>		<i>Diameter</i>
16 in.	...	19½ in. × 14½ in.
15 in.	...	17½ in. × 12½ in.
14 in.	...	16 in. × 12 in.



No. B 2056 ANGULAR LIPPED URINAL

With Flushing Rim and Secret overflow

<i>Height</i>		<i>Diameter</i>
16 in.	...	19½ in. × 18 in.
15 in.	...	17½ in. × 16 in.
14 in.	...	16 in. × 15 in.





No. B 2135

**AUTOMATIC
FLUSHING TANK**

Including trapping box and horizontal outlet, all made of sheet steel galvanized after manufacture, complete with heavy gauge siphon with outlet suitable for connecting to the socket of a cast-iron obtuse bend of 115°.

Dimensions

Approx. Flush gallons	Length	Width	Depth of Tank excluding bottom trap	Size of Outlet recommended
10	18 in.	14 in.	14 in.	3 in.
15	20 in.	16 in.	18 in.	4 in.
20	21 in.	18 in.	18 in.	4 in.
25	24 in.	19 in.	18 in.	4 in.
30	25 in.	21 in.	18 in.	4 in.
40	27 in.	21 in.	24 in.	4 in.
50	27 in.	24 in.	24 in.	4 in.
60	33 in.	24 in.	24 in.	4 in.
80	38 in.	28 in.	24 in.	5 in.
100	42 in.	30 in.	24 in.	5 in.

As an alternative, we can supply the same tank with a horizontal or vertical outlet.

No. B 2136

SUPPLY TAP

For Automatic Tanks

Can be regulated with a screw-driver. With backnut and bent tail. Brass. Size $\frac{3}{8}$ in.



No. B 2138

SUPPLY TAP

For Automatic Tanks

B.S. 1010

With loose key and guard. Backnut and bent tail. Polished brass. Size $\frac{3}{8}$ in.



No. B 2120

**AUTOMATIC FLUSHING
CISTERN**

White glazed heavy fireclay fitted with copper siphon, complete with porcelain-enamelled cast-iron brackets and suitable drip tap.

Capacity : 1 2 3 4 6 galls.
Outlet Size : 1 1 1 1½ 1½ in.



No. B 2125

**AUTOMATIC FLUSHING
CISTERN**

Plain-painted cast-iron with copper siphon, outlet supplied for lead or iron pipe, brackets and drip taps supplied if specified (extra).

Capacity : 1 2 3 4 5 6 8 galls.
Outlet Size : 1 1 1½ 1½ 1½ 1½ in.

Cast-iron covers to suit can be supplied if ordered.



No. B 2090



No. B 2101



No. B 2091



No. B 2100

No. B 2090. URINAL GRATING

Dome shaped, made in polished brass with 3½ in. flange, 3½ in. long thread and backnut. Screwed 2 in. iron.

No. B 2101. COPPER AUTOMATIC SIPHON

With 2½ in. long thread and backnut. Sizes : 1 in., 1½ in., 1½ in.

No. B 2091. DOME-SHAPED URINAL GRATING

Polished brass with 3½ in. flange, ½ in. long spigot outlet measuring 2½ in. o/d.

No. B 2100. BUTTON SPREADER

Polished brass, screwed ½ in. female iron.

No. B 6355 B I D E T



Best Quality White-glazed Earthenware. Modern pattern with rectangular base and soap dish draining into overflow. Fittings comprising two $\frac{1}{2}$ in. cold chromium-plated control valves supplying water to rim and ascending spray $1\frac{1}{4}$ in. plug and chain waste.

Overall Size :

23 in. long \times 14 in. wide

No. B 6356 B I D E T

Best Quality White-glazed Vitreous China.

A new design on bold simple lines. Fittings comprising three $\frac{1}{2}$ in. chromium-plated control valves supplying hot and cold water to spray and hot to rim ; $1\frac{1}{4}$ in. plug and chain waste fitting.

Overall Size :

24 in. long \times 14 in. wide



Both the above bidets can be supplied with ware in colours

Further details on request

THE "TORCADE" COMPOSITION LOW-LEVEL
FLUSHING CISTERN



Comprising black mirror-finish casing and cover, to B.S.S. 1125/46, with white or red plastic bead around cover; $1\frac{1}{2}$ in. copper and white metal siphon of special design to give an easy flush.

No. B 6365
TORCADE CISTERN
WITH C.P. FRONT LEVER

Fittings include $\frac{1}{2}$ in. ball valve, $\frac{3}{4}$ in. overflow, wall brackets, and white porcelain-enamelled flushpipe. The above cisterns can also be supplied with all-copper siphons if required. (Extra.)



No. B 6366

TORCADE CISTERN
WITH C.P. SIDE LEVER



TORCADE
WHITE EARTHENWARE VALVELESS SIPHON CISTERNS
 Including $1\frac{1}{4}$ in. or $1\frac{1}{2}$ in. siphon of white metal or all brass, $\frac{1}{2}$ in. ball valve, $\frac{3}{4}$ in. overflow, brass chain and white china pull ; external fittings supplied either polished brass or chromium-plated.

No. B 2545
CISTERN

As described above, without cover.

No. B 2547
CISTERN

As described above, with cover.



No. B 6370
FORDHAM
LOW LEVEL VALVELESS SIPHON
CISTERN
 B.S.S. 1125/46.

Casing in W.P.E. pressed steel, $1\frac{1}{2}$ in. siphon in copper or Polythene with chromium-plated front lever, $\frac{1}{2}$ in. ball valve, $\frac{3}{4}$ in. overflow, white porcelain-enamelled flushpipe and concealed fixing brackets.

To flush 2, $2\frac{1}{2}$, or 3 gallons.



No. B 6371
FORDHAM
PANEL TYPE VALVELESS SIPHON
CISTERN

Valuable space is saved by the shallow design, projecting only 6 in. from the wall. The outer cover made of W.P.E. steel is easily detachable by uncoupling a single screw. The steel inner shell is fitted with $1\frac{1}{2}$ in. siphon in copper with chromium-plated lever handle ; including $\frac{1}{2}$ in. ball valve, $\frac{3}{4}$ in. overflow and W.P.E. flushpipe.

To flush 2, $2\frac{1}{2}$ or 3 gallons.

These cisterns are normally sent out with side supply and overflow. Bottom supply and overflow (as illustrated) can be supplied to order. (Extra.)

No. B 6367

"TORCADE" COMPOSITION VALVELESS SIPHON CISTERN

To B.S.S. 1125/46.

Comprising mirror finish flat-bottomed case (and cover if required) $1\frac{1}{4}$ in. copper and white metal siphon of special design, $\frac{1}{2}$ in. ball valve, $\frac{3}{4}$ in. overflow, galvanized chain and wood pull.

To Flush : 2, $2\frac{1}{2}$, or 3 gallons.

All Copper Siphon also Supplied. (Extra.)



No. B 6368

"FORDHAM" VALVELESS SIPHON CISTERN

To B.S.S. 1125/46.

Comprising white porcelain-enamelled steel casing and cover, with $1\frac{1}{4}$ in. copper or Polythene siphon, $\frac{1}{2}$ in. ball valve, $\frac{3}{4}$ in. overflow, galvanized chain and pull, concealed fixing brackets.

To Flush : 2, $2\frac{1}{2}$ or 3 gallons.

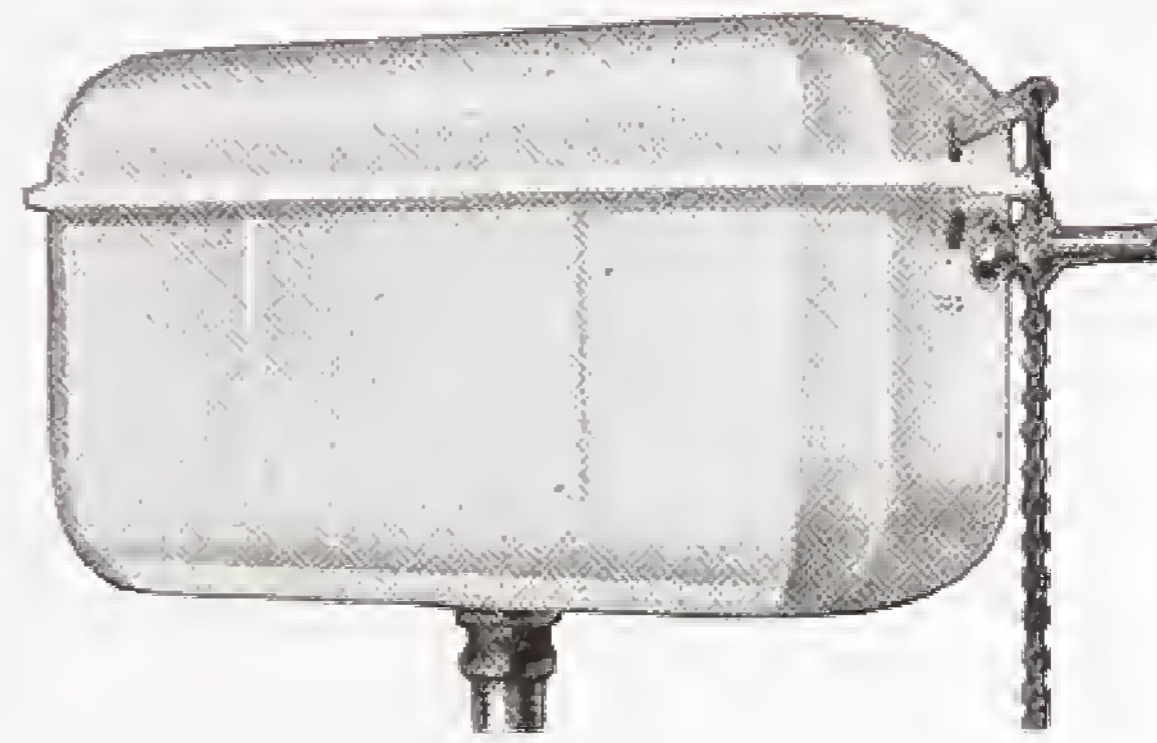

No. B 6369

A.B.M. "INSTANT FLUSH" BITUMEN REVERSIBLE CISTERN

Comprising highly-glazed non-corrosive casing and cover with bell siphon ; $1\frac{1}{4}$ in. outlet, $\frac{1}{2}$ in. ball valve, $\frac{3}{4}$ in. overflow ; concealed supporting brackets, chromium-plated chain and Polythene pull.

To Flush 2 gallons.

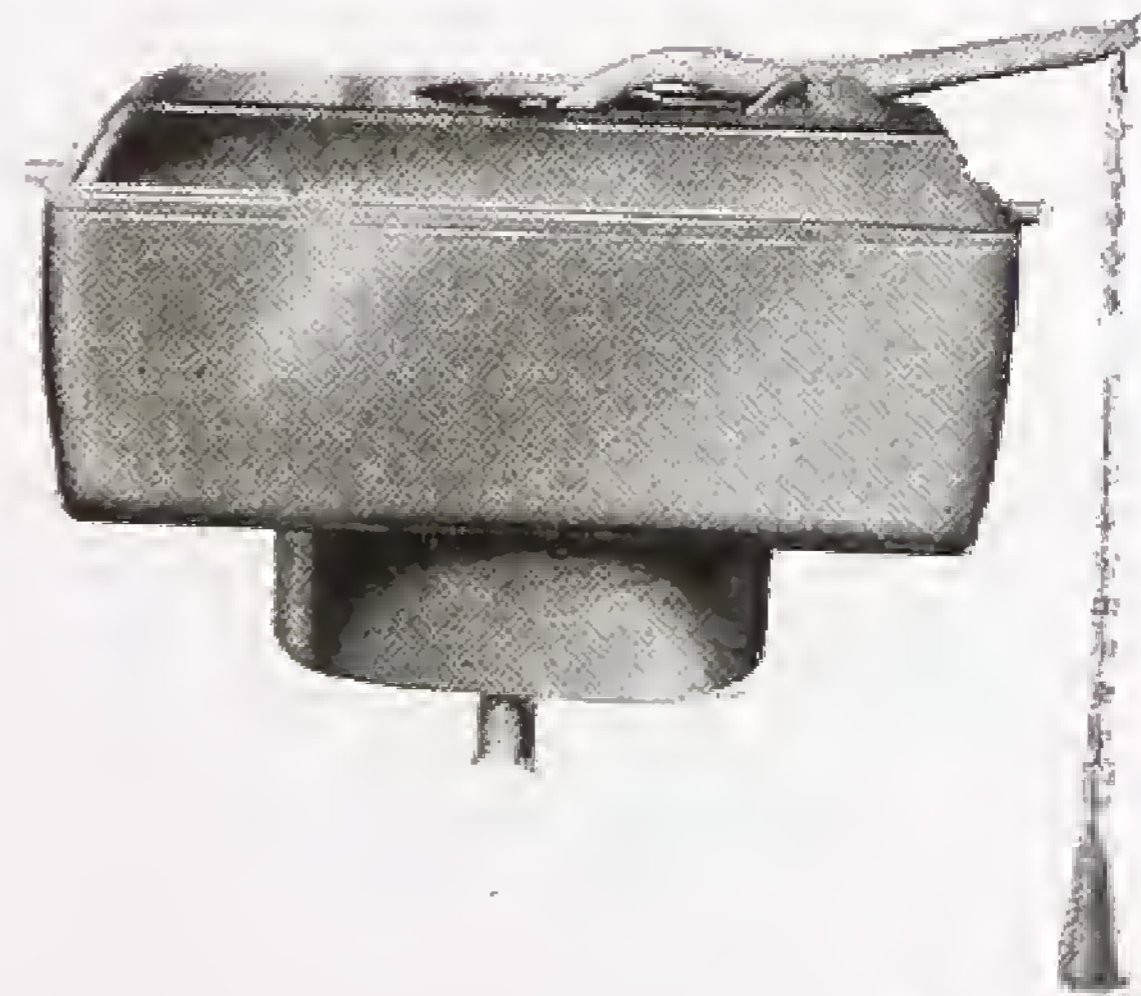

No. B 2520

LODORE VALVELESS SIPHON CISTERN



Cast-iron.

With $\frac{1}{2}$ in. M.O.H. hot pressed ball valve, $\frac{1}{2}$ in. overflow, galvanized chain and pull.

To Flush : 2, $2\frac{1}{2}$, or 3 gallons

Also supplied :

White porcelain-enamelled outside, plain painted inside, with brass chain and china pull.

To Flush : 2, $2\frac{1}{2}$, or 3 gallons

No. B 6372

A.B.M. "PARSALL" VALVELESS SIPHON CISTERN



Cast-iron "Country" pattern with $\frac{1}{2}$ in. M.O.H. ball valve, $\frac{1}{2}$ in. overflow, galvanized chain and rubber pull. Self-contained hanging lugs (no brackets required). To flush 2 or 3 gallons.

No. B 2535

VALVELESS SIPHON CISTERN



Cast-iron

With $\frac{1}{2}$ in. two-piece ball valve, $\frac{3}{4}$ in. overflow, galvanized chain and pull, as supplied for Newcastle and Sunderland districts.

To Flush 2 gallons.

TELESCOPIC FLUSHPIPES

Seamless steel. Galvanized. The upper portion slides into the lower and permits of about 6 in. vertical adjustment. Each portion can then also be turned to the right or left, and fixed at any angle. The size of pipe named represents the bore of the upper pipe.

No. B 1660 FLUSH PIPE

5 ft. 6 in. long, $1\frac{1}{4}$ in., $1\frac{3}{8}$ in. or $1\frac{1}{2}$ in. bore.

Can be fitted with an air pipe when required (extra).



No. B 1659 VILLA PATTERN FLUSHPIPE

Two-piece

Standard dimensions are :
A $4\frac{1}{2}$ in., B 8 in., C 16 in., D 16 in.

5 ft. 6 in. long, $1\frac{1}{4}$ in., $1\frac{3}{8}$ in. or $1\frac{1}{2}$ in. bore.

Can be fitted with an air pipe when required (extra).

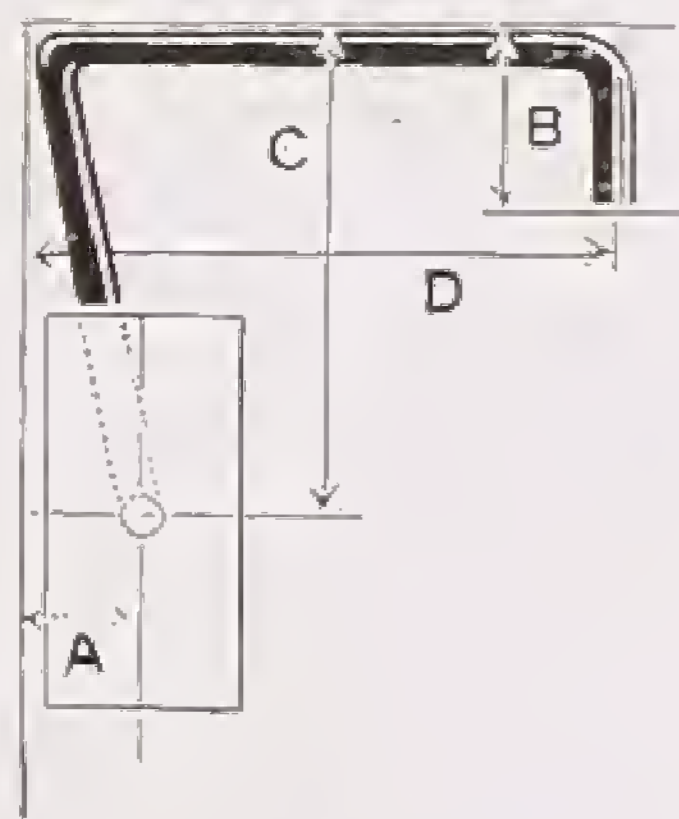

Plan (left-hand position)

The following dimensions are required with all orders for flushpipes.

1. Villa pattern—A, B, C, D, E, F.
 2. Ordinary pattern—A, B, E, F.
- A. Distance from wall to centre of cistern outlet.
B. Length of return bend.
C. Distance from cistern outlet to wall corner.
D. Distance from closet inlet to wall corner.
E. Overall length.
F. Bore.

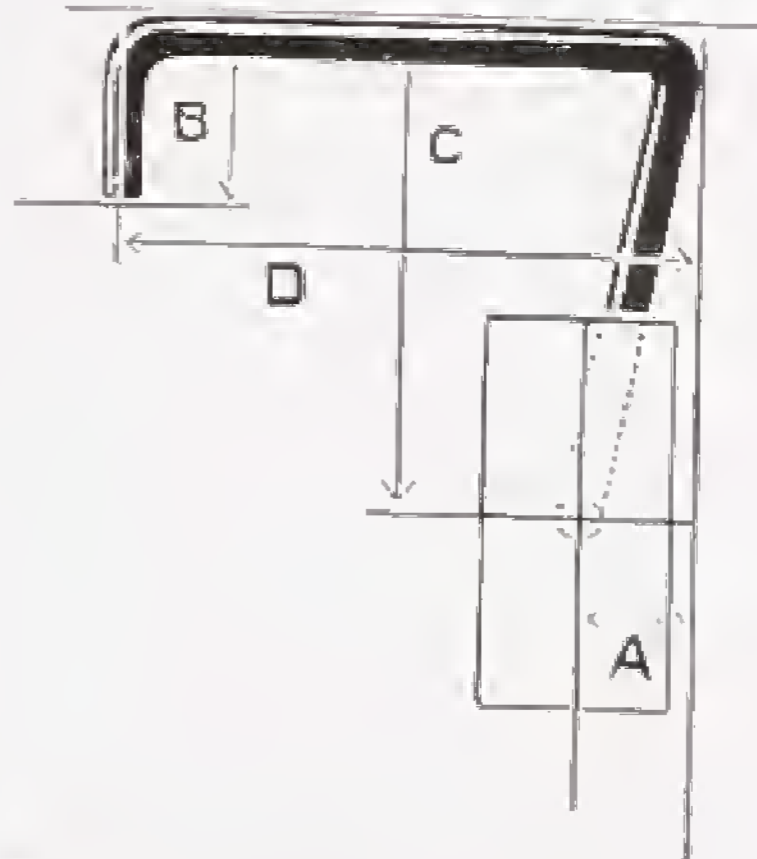

Plan (right-hand position)

Flushpipes can also be supplied in polished or chromium-plated copper.

FLUSH PIPE CLIPS

B 2576. Plain Clip.

B 2577. Clip with
Rubber Buffer.

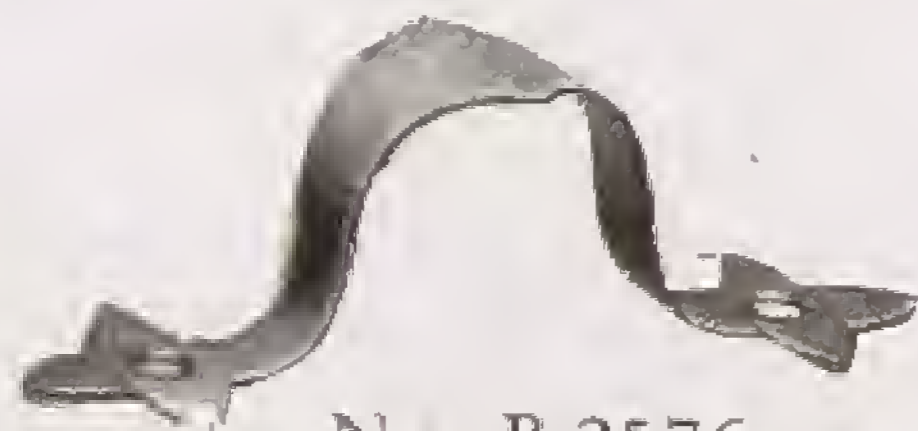

No. B 2576

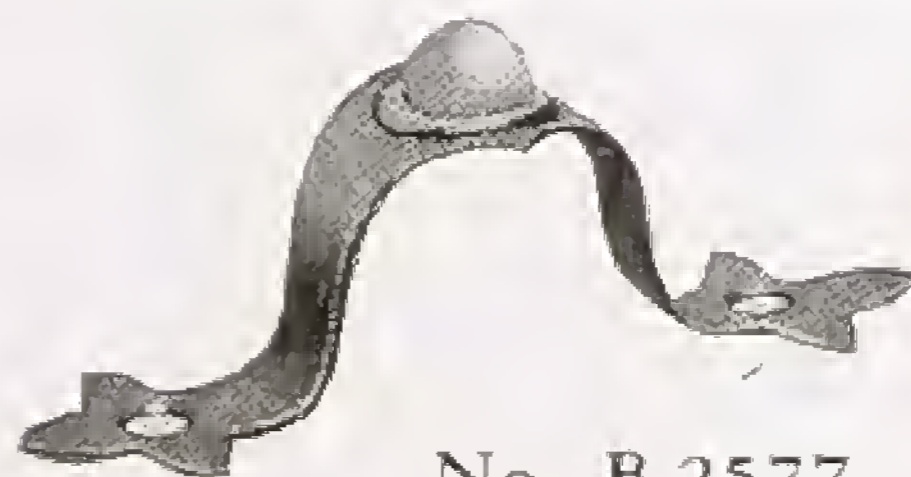

No. B 2577

Made in polished or chromium-plated brass, or galvanized steel. Sizes $1\frac{1}{4}$ or $1\frac{1}{2}$ in.

CISTERN FITTINGS, Etc.



No. B 945
TORCADE



No. B 947
JAP-KAP

VALVELESS SIPHONS

To suit cisterns 8 $\frac{3}{4}$ -in. deep inside. Siphon of hard white metal and brass. Cast-iron lever, brass outlet with backnut and union.

Size 1 $\frac{1}{4}$ 1 $\frac{1}{2}$ in.

No. B 2593
W.C. DEODORISER

Automatically discharges a finely atomised scented spray each time the chain is pulled. Complete with coloured rubber handle. Chromium-plated.

No. B 2592
CISTERN PULL GUIDE

Galvanized steel, 1-in. diam. 24-in. long, with cast-iron brackets, 4 $\frac{1}{2}$ -in. wall to centre. With galvanized chain pull 36-in. long and stirrup handle

CAST-IRON CISTERN BRACKETS



B 2583

8

White
porcelain-enamelled



B 2585

9 10 11

Plain-
painted

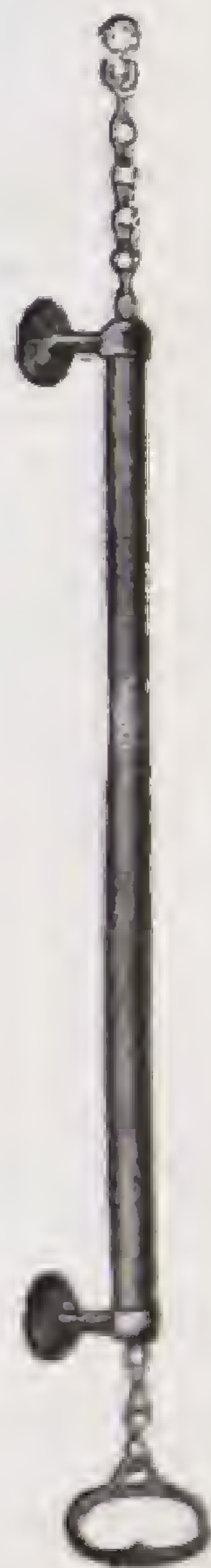

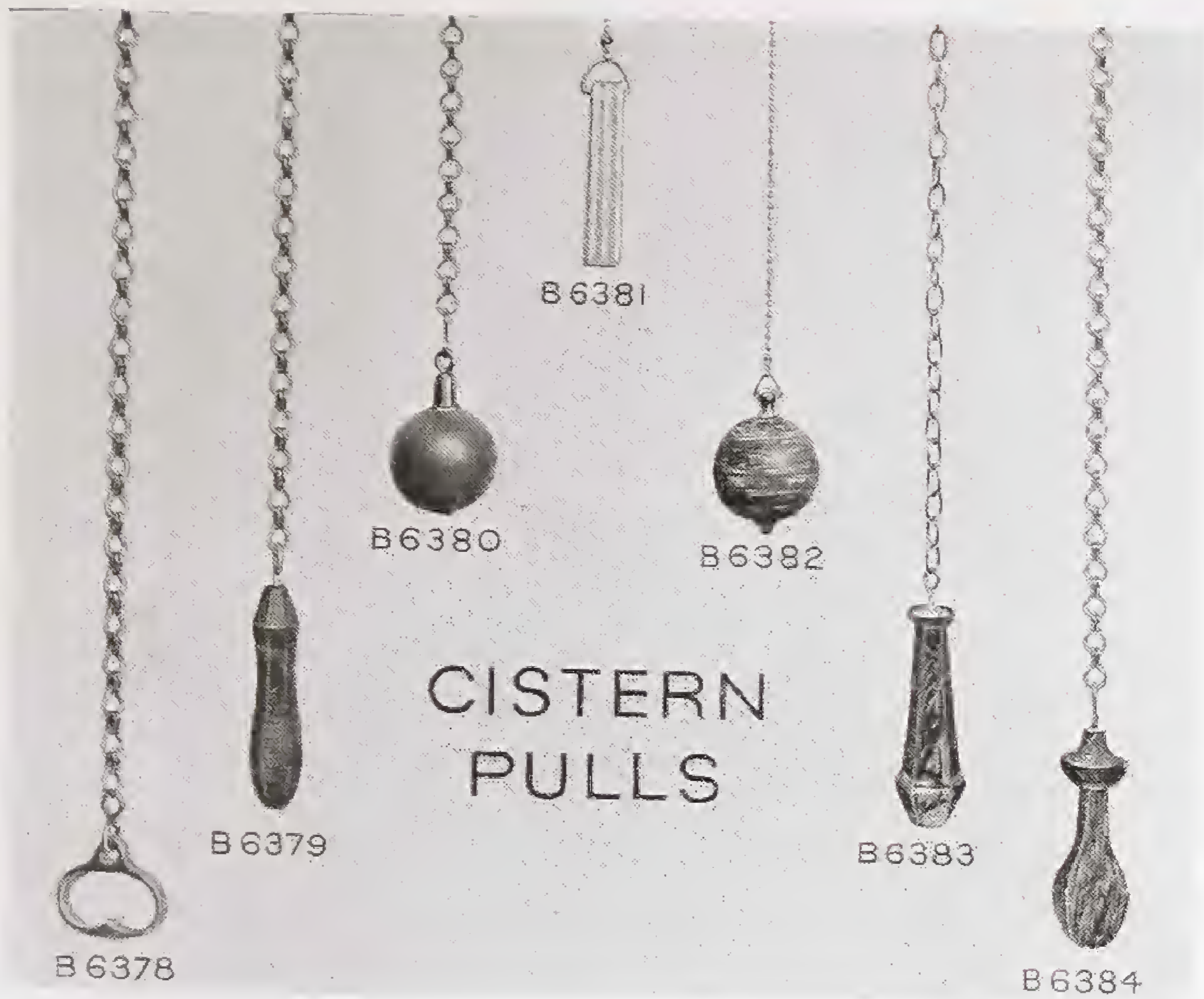

- B6378 Galvanized chain, stirrup handle.
 B6379 Galvanized chain, varnished wood handle.
 B6380 Chromium-plated link chain, Sorbo rubber ball handle in assorted colours.
 B6381 Chromium-plated ball pattern chain with Perspex handle, in various colour combinations.
 B6382 Chromium-plated ball pattern chain with rubber ball pull in marbled colours.
 B6383 Chromium-plated solid link chain with hexagon rubber handle in marbled colours.
 B6384 Chromium-plated link chain with rubber pagoda shaped handle in marbled colours.



No. B 2591
 CISTERN PULL GUIDE
 Polished Brass or Chromium-plated.
 Measurement ;
 wall to
 centre $4\frac{1}{2}$ 5 6 in.

BIB TAPS

Polished Brass BS 1010 Patterns



No. B 115
BIB TAP
Round Crutch Type. Plain tail for lead.
Sizes $\frac{1}{2}$ in., $\frac{3}{4}$ in., 1 in.



No. B 160
BIB TAP
Round Crutch Type. Screwed male iron
Sizes $\frac{1}{2}$ in., $\frac{3}{4}$ in., 1 in.



No. B 209
BIB TAP
With Capstan Head Indexed.
Plain tail for lead.
Sizes $\frac{1}{2}$ in., $\frac{3}{4}$ in., 1 in.



No. B 227
BIB TAP
With Capstan Head Indexed.
Screwed male iron.
Sizes $\frac{1}{2}$ in., $\frac{3}{4}$ in., 1 in.



No. B 228
As above. With boss.

No. B 230
BIB TAP
Round Crutch Type with Hose Union.
Screwed male iron.
Sizes: $\frac{1}{2}$ in., $\frac{3}{4}$ in., 1 in.

No. B 229
As above with plain tail for lead.

All above can be supplied with
ferrule guard and loose key.

BIB TAPS

Chromium-plated B.S. 1010 Patterns.



No. B 235
BIB TAP

With capstan head, indexed.
Plain tail for lead.
Sizes $\frac{1}{2}$ in. and $\frac{3}{4}$ in.



No. B 236
BIB TAP

With capstan head, indexed.
Screwed male iron.
Sizes $\frac{1}{2}$ in. and $\frac{3}{4}$ in.

All indexed taps can be supplied lettered Hot, Cold or Soft.
Please state which is required when ordering.



No. B 239
BIB TAP

With capstan head, indexed, and
bottling nose; screwed male iron.
Size $\frac{1}{2}$ in.



No. B 241
BIB TAP

With capstan head, indexed.
Anti-splash nozzle; screwed male iron.
Size $\frac{1}{2}$ in.

No. B 603

COMBINATION SINK MIXER



Chromium-plated, with swivel nozzle, for double or single sinks.

A generous length of nozzle gives a wide arc of delivery with all positions of fixing and the nozzle height gives full clearance for all purposes. Pattern illustrated has $\frac{1}{2}$ in. screwed tails with backnuts, but the fitting can also be supplied with extended tails 12 in. long.

Made to B.S. 1010 specification.

No. B 604

SWIVEL SINK FITTING DUAL FLOW TYPE



To meet the requirements of the increasing number of Authorities whose Bye-Laws demand that the usual combination tap be fed from a separate tank for the cold supply, this dual flow swivel sink fitting has been introduced. The passages for hot and cold water are separate throughout their length, avoiding all danger of feedback from either side.

The fitting illustrated is $\frac{1}{2}$ in. size with 3 in. long tails and backnuts, but can be supplied with 12 in. extended tails if required.

Made to B.S. 1010 specification.

No. B 627

**SWIVEL FITTING FOR
HOSPITAL SINKS AND
BASINS**

Chromium-plated

Quarter turn valves fitted with
levers 7 in. long and anti-splash
nozzle.

Reversible Unions.

Sizes : $\frac{1}{2}$ in., $\frac{3}{4}$ in

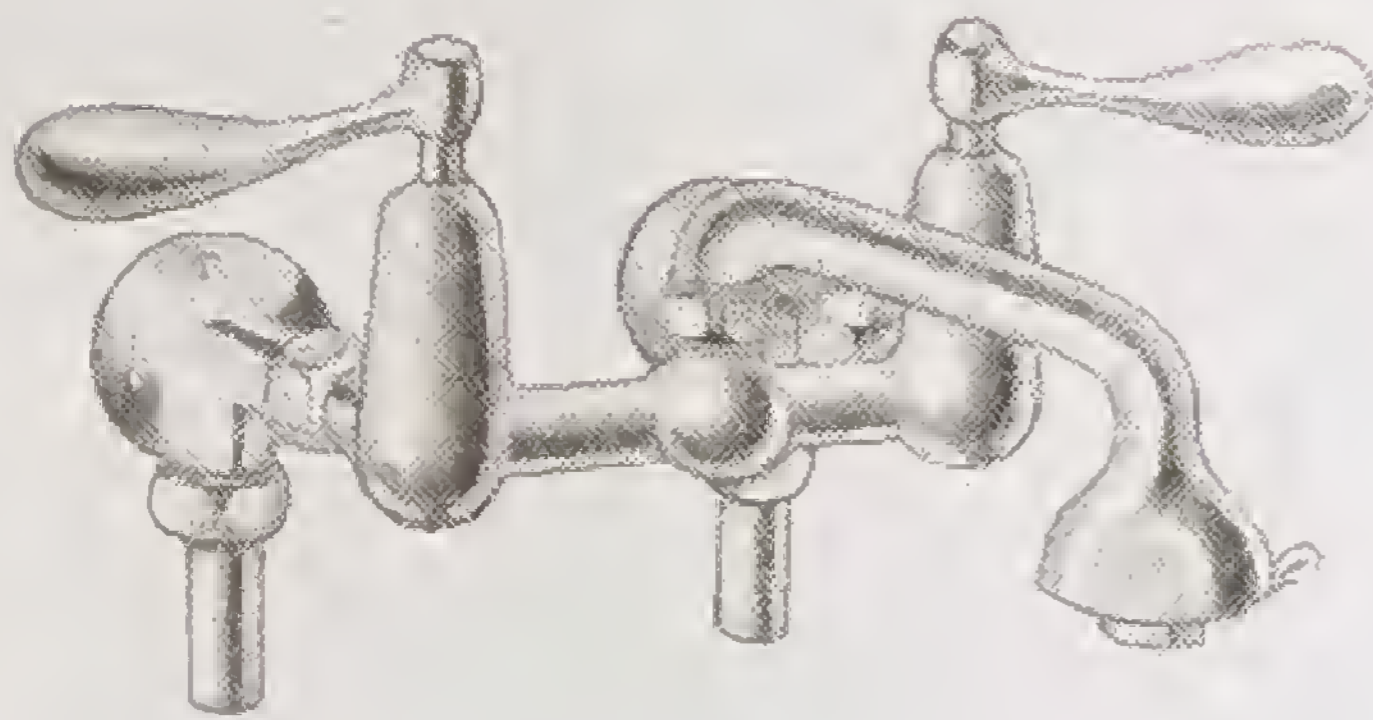
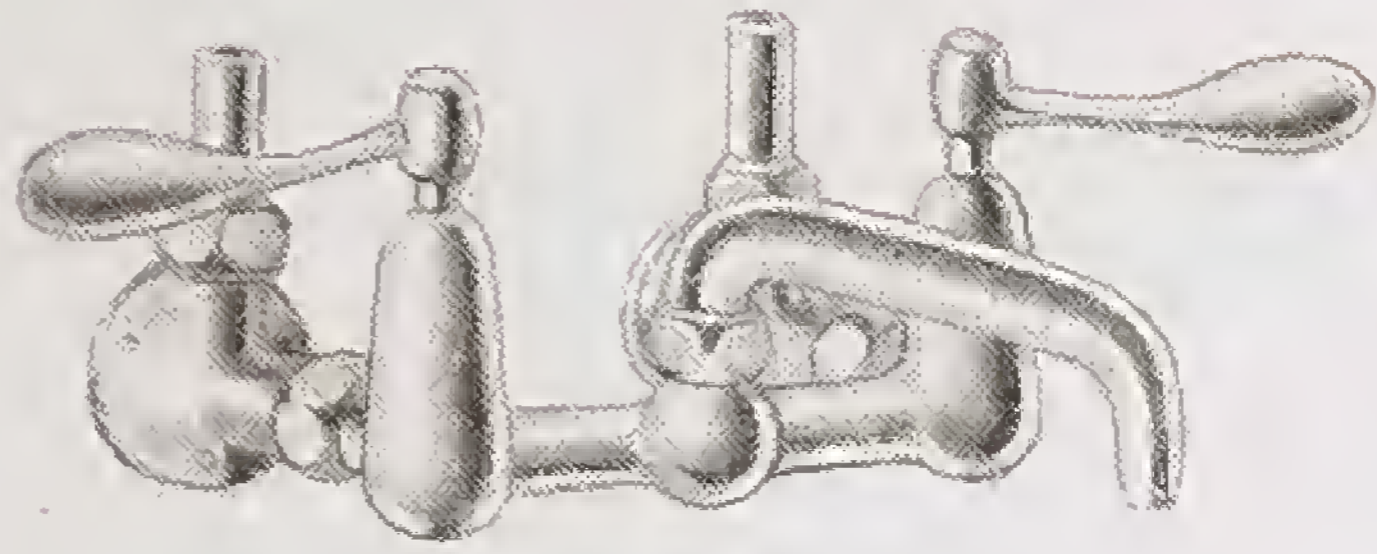

No. B 628

**SWIVEL FITTING FOR
HOSPITAL SINKS AND
BASINS**

Chromium-plated

Quarter turn valves with levers
7 in. long and jet or spray nozzle.

Reversible Unions.

Sizes : $\frac{1}{2}$ in., $\frac{3}{4}$ in.

No. B 629

**SURGEONS' LAVATORY
BASIN FITTING WITH
SWIVEL SWAN NECK**

Chromium-plated.

Elbow action quarter turn valves
with 7 in. levers ; alternative jet
and spray nozzle or spray nozzle
outlet only, or anti-splash outlet
only. Can also be supplied with
fixed swan neck.

Sizes : $\frac{1}{2}$ in., $\frac{3}{4}$ in.

N.B. When ordering, please
state what centres are required.

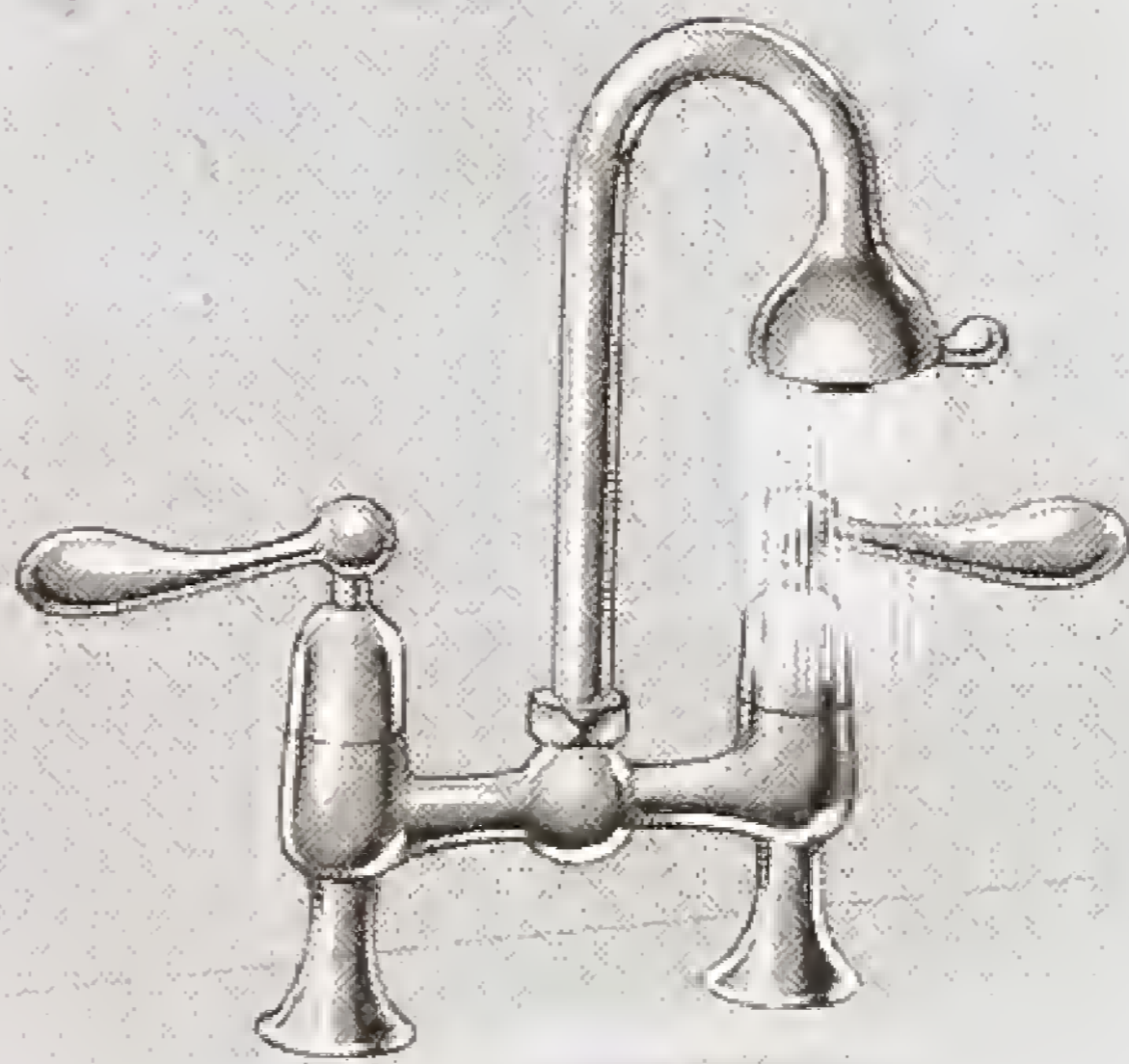

PLUG COCKS



No. B 715

PLUG BIB COCK

Polished brass with ebonite lever.
Screwed male iron.

Sizes : $\frac{1}{2}$, $\frac{3}{4}$, 1 in.



No. B 716

"FOLD-IN" PLUG COCK

Chromium-plated with ebonite lever.
Screwed male iron.

Size : $\frac{1}{2}$ in.

This tap is specially designed so that the nozzle turns sideways with the lever.



No. B 717

FULLWAY BIB COCK

Polished brass with loose iron lever.
Screwed male iron.

Sizes : $\frac{1}{2}$, $\frac{3}{4}$, 1 in.

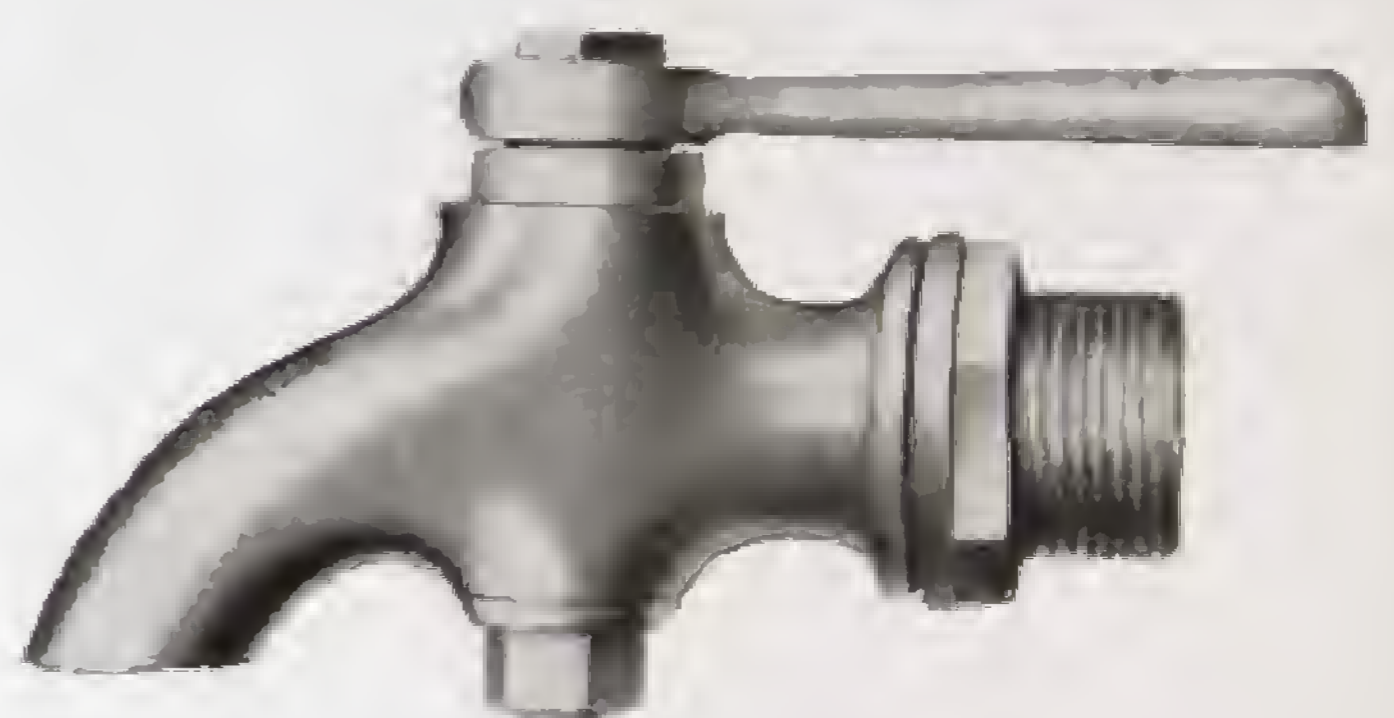

No. B 718

PLUG COCK

Rough brass with loose brass lever.
Screwed male iron with backnut.

Sizes : $\frac{1}{2}$, $\frac{3}{4}$, 1 in.



No. B 719

RANGE COCK

Polished brass with ebonite lever.
2 in. male thread with backnut.

Sizes : $\frac{3}{4}$, 1 in.

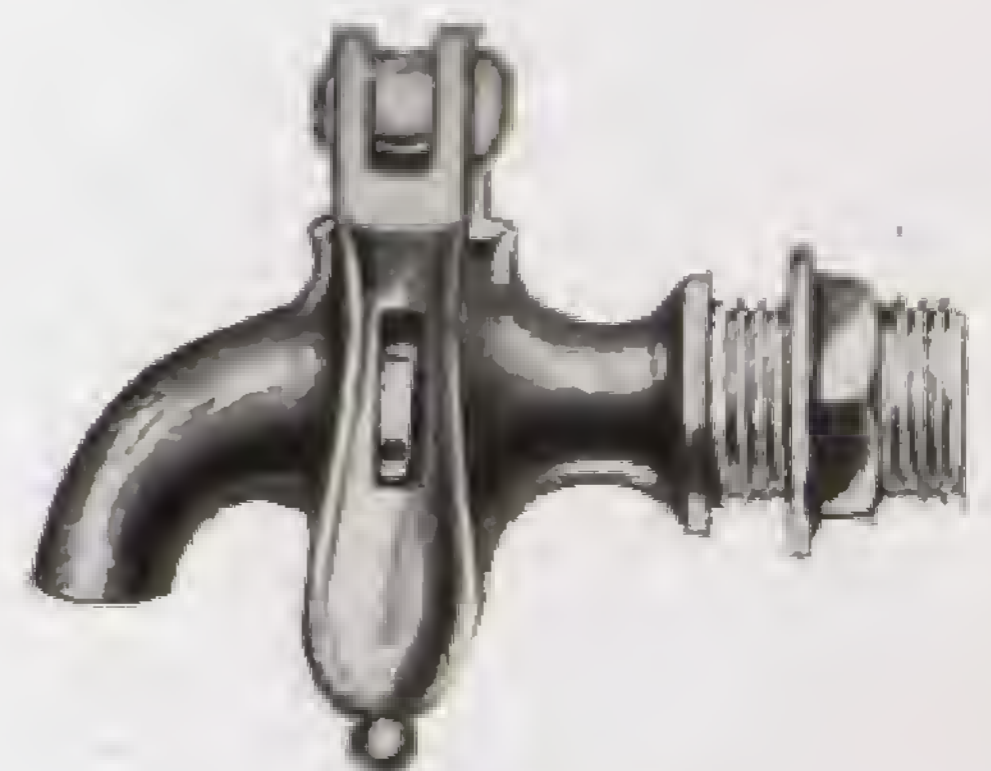

No. B 650
TANK COCK

Polished Brass With iron hinged locking lever for padlock.
Screwed male iron with backnut.

Sizes : $\frac{1}{2}$, $\frac{3}{4}$, 1 in.

SELF-CLOSING TAPS



No. B 605

SELF-CLOSING BIB TAP

Polished Brass or Chromium-plated.
Non-concussive. Screwed for iron.

No. B 606

As above, with screwed boss for lead.

Sizes : $\frac{1}{2}$ in., $\frac{3}{4}$ in. and 1 in.

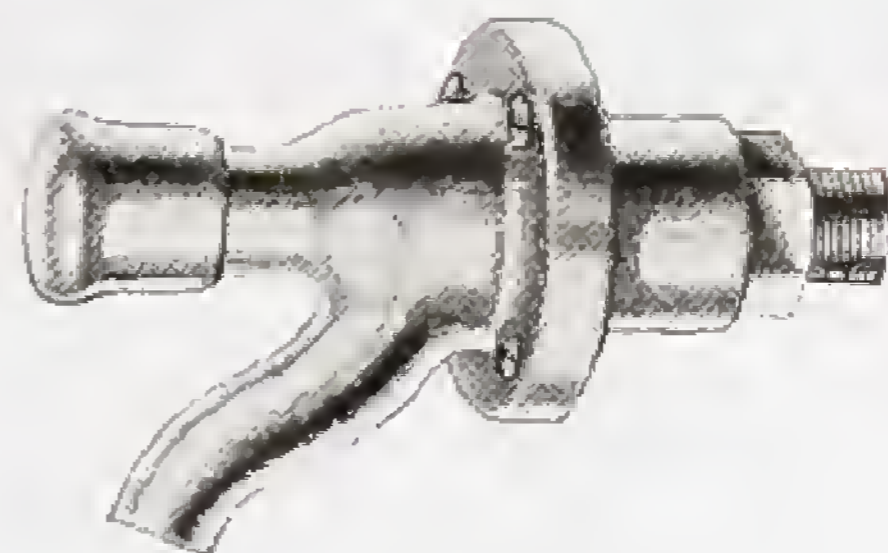

No. B 615

SELF-CLOSING TAP

Polished Brass or Chromium-plated.
Non-concussive. Screwed for iron.

Size : $\frac{1}{2}$ in.



No. B 601

SELF-CLOSING BIB TAP

A stream-lined non-concussive chromium-plated tap with push-button operation, screwed for iron.

Sizes : $\frac{1}{2}$ in. and $\frac{3}{4}$ in.

If possible please give approximate water pressure when ordering Self-closing Taps



No. B 602

SELF-CLOSING STOP TAP

Non-concussive pattern with push-button operation; screwed female ends for iron. Chromium-plated.

Size : $\frac{1}{2}$ in.

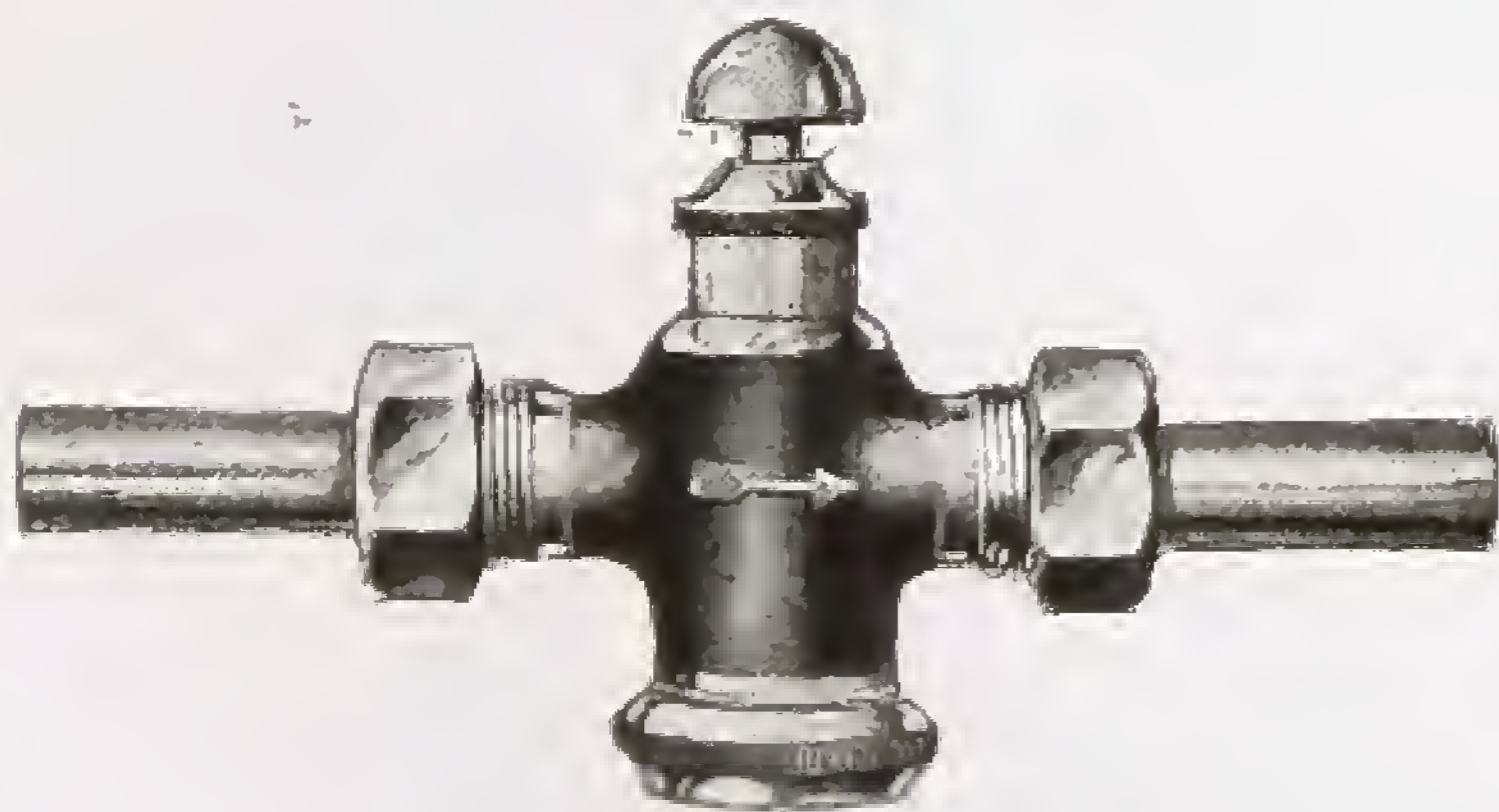

No. B 612

STOP TAP

Non-concussive self-closing type, with two unions for lead. Brass Unpolished.

Sizes : $\frac{1}{2}$ in. and $\frac{3}{4}$ in.

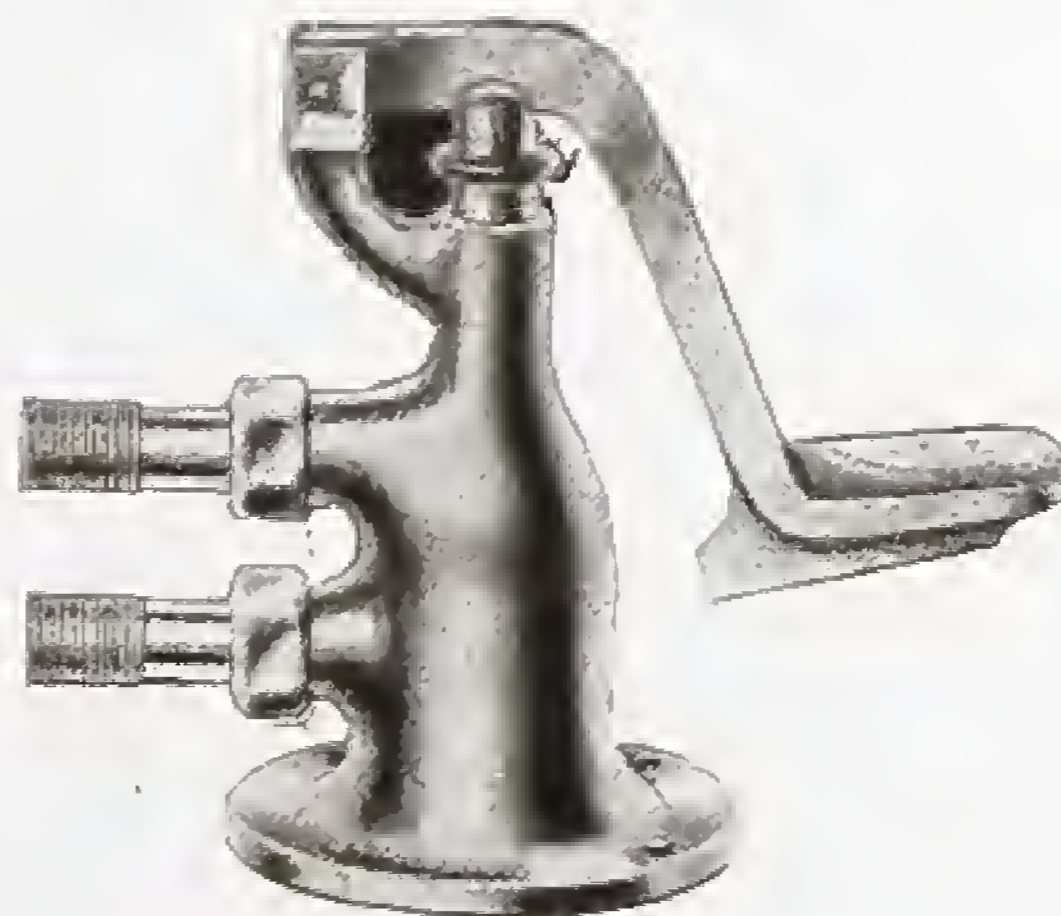

No. B 617

FOOT OPERATED CONTROL TAP

Polished Brass or Chromium-plated. Non-concussive. Self-closing type with screwed unions for iron pipe.

Size : $\frac{3}{4}$ in.

GUN-METAL LABORATORY FITTINGS

All smooth-body pattern.



No. B 1016
Screw-down stop cock with wheel handle and corrugated nozzle for rubber tube.
Inlet $\frac{1}{2}$ -in. iron.
Polished, Black Bronzed, Chromium-plated.

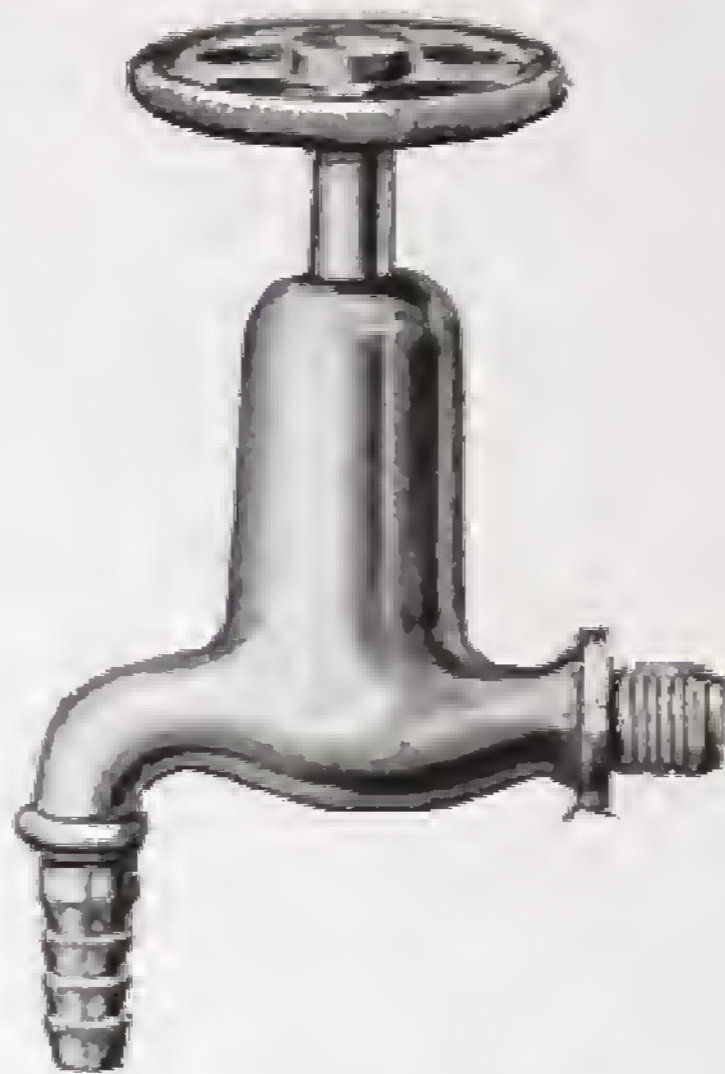

No. B 1017
Screw-down bib cock with wheel handle and corrugated nozzle for rubber tube.
Inlet $\frac{1}{2}$ -in. iron.
Polished, Black Bronzed, Chromium-plated.



No. B 1018
Screw-down bib cock with capstan head and long angle corrugated nozzle for rubber tube.
Inlet $\frac{1}{2}$ -in. iron.
Polished, Black Bronzed, Chromium-plated.

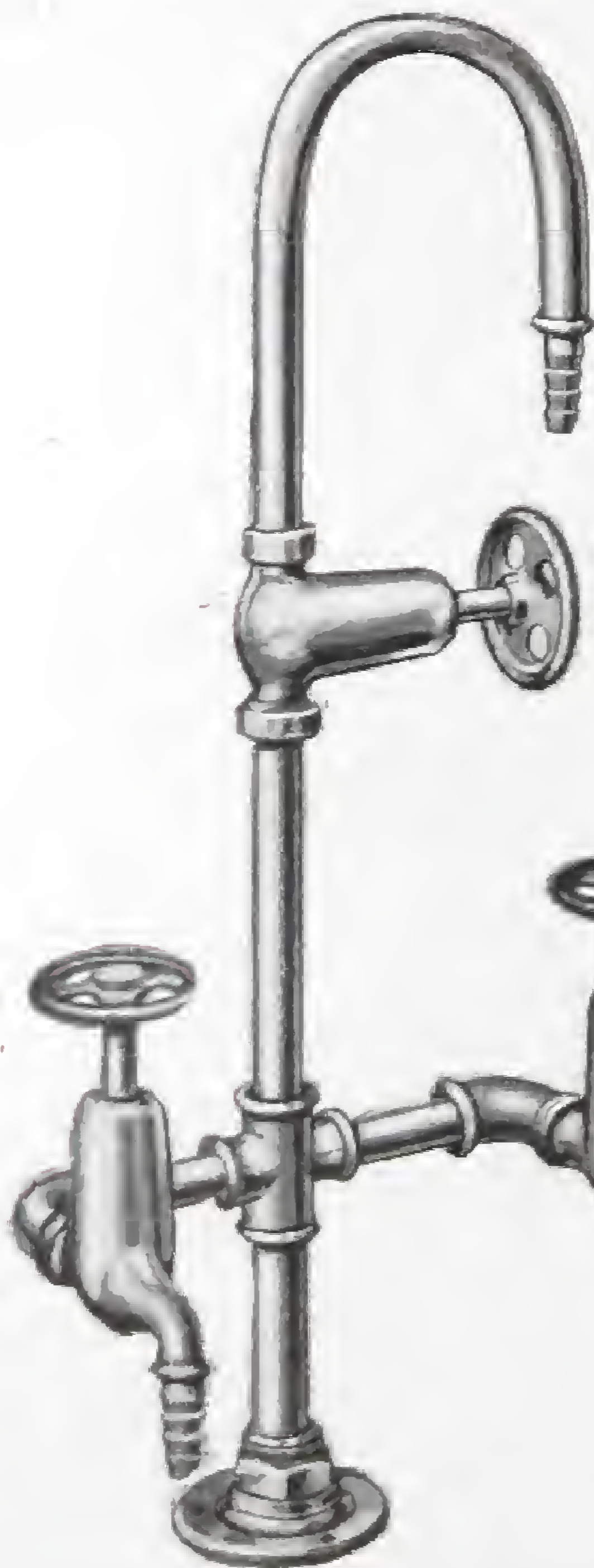

No. B 1023
Three-way Standard fitting, with swan neck in $\frac{1}{2}$ -in. strong copper tube. Inlet, $\frac{1}{2}$ -in. iron. Height from base to nose, $14\frac{1}{2}$ in.
Polished, Black Bronzed, Chromium-plated.

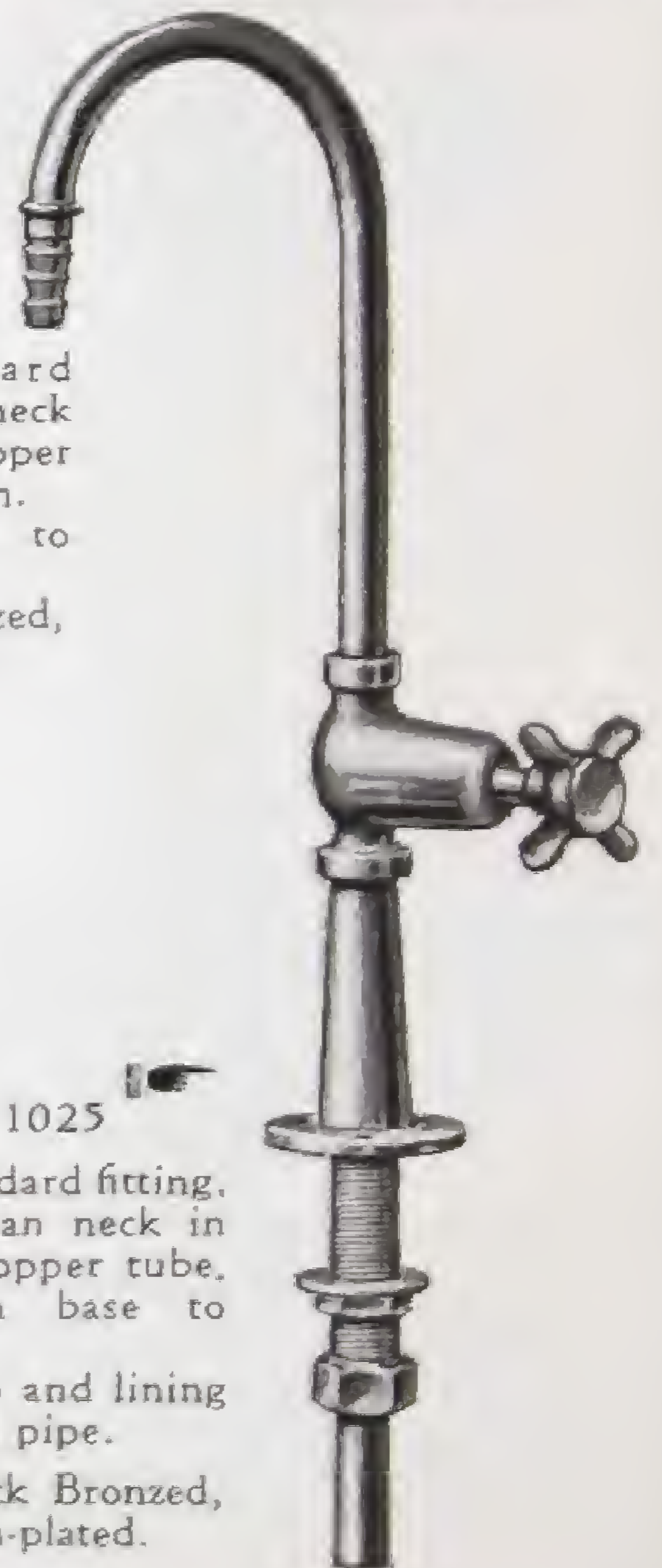

No. B 1025
One-way Standard fitting, with fixed swan neck in $\frac{1}{2}$ -in. strong copper tube. Height from base to nose, 9 in. Inlet with cap and lining for $\frac{1}{2}$ -in. lead pipe.
Polished, Black Bronzed, Chromium-plated.

GUN-METAL LABORATORY FITTINGS

All smooth-body pattern.

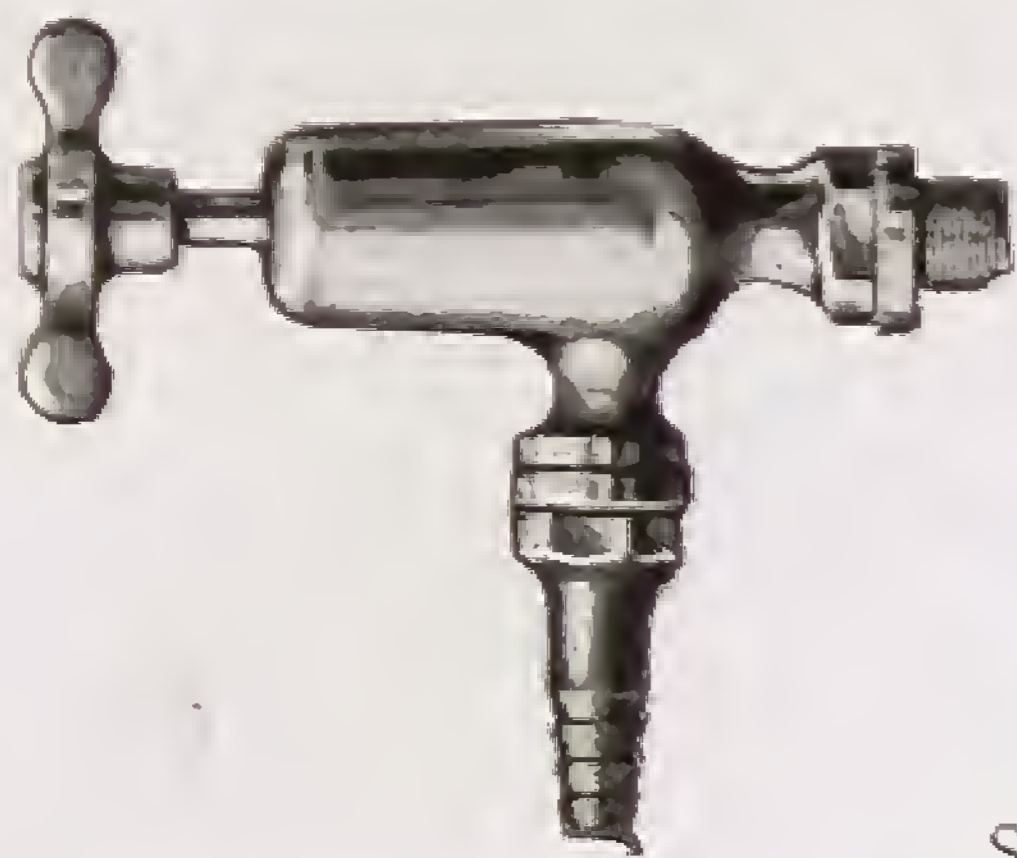

No. B 1021
Screw-down side cock with capstan head and corrugated nozzle for rubber tube. Inlet $\frac{1}{4}$ -in. iron.

Polished. Black Bronzed. Chromium-plated.



No. B 1020
Screw-down stop cock with wheel handle. Screwed $\frac{1}{4}$ -in. iron male.

Polished.
Black Bronzed.
Chromium-plated.

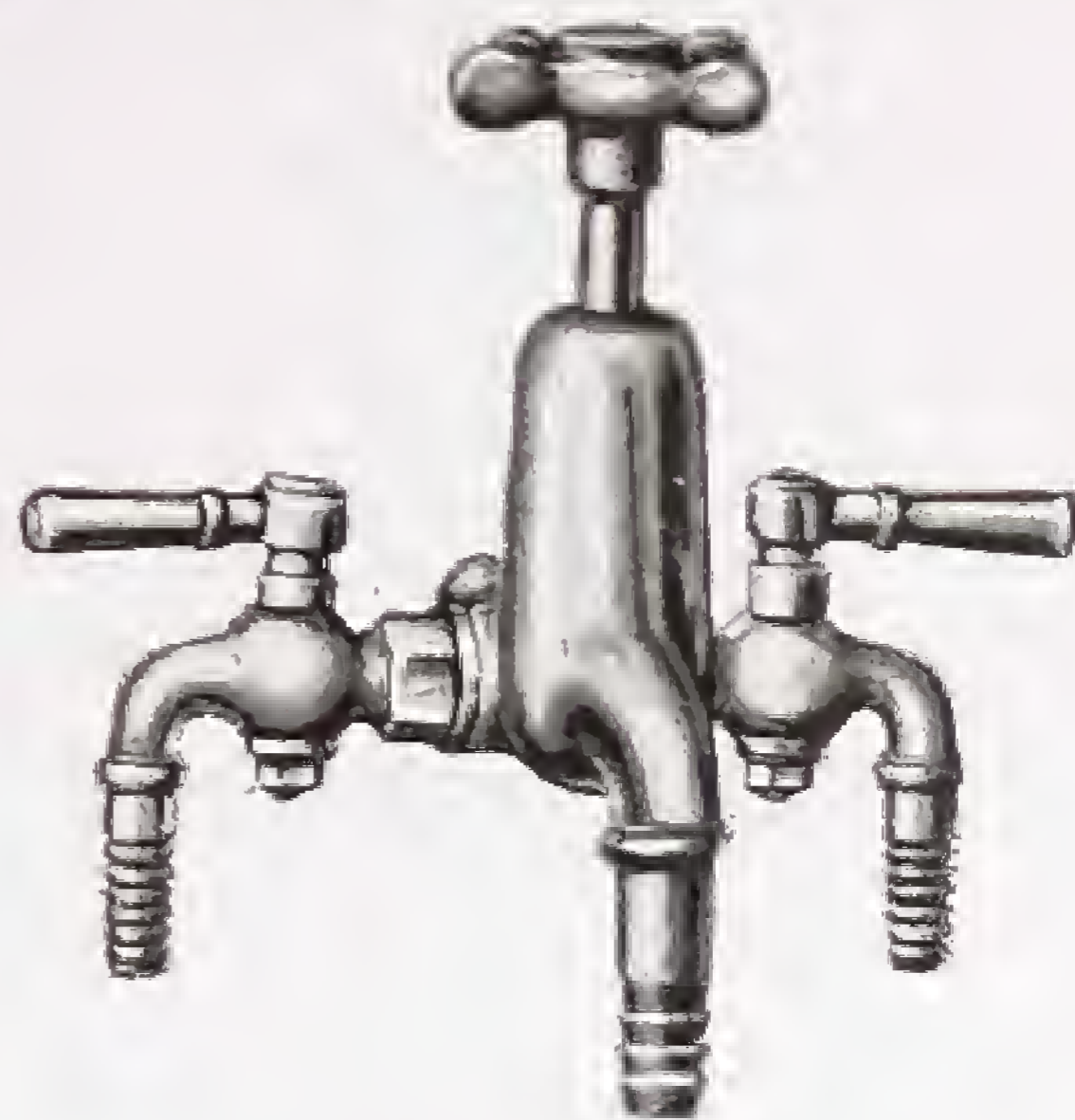

No. B 1019
Screw-down bib cock with capstan head, corrugated nozzle for rubber tube and screw ferrule inlet for

connecting to lead pipe, fitted with two side cocks. Shank of cock screwed $\frac{3}{8}$ -in. iron.

Polished.
Black
Bronzed.
Chromium-plated.

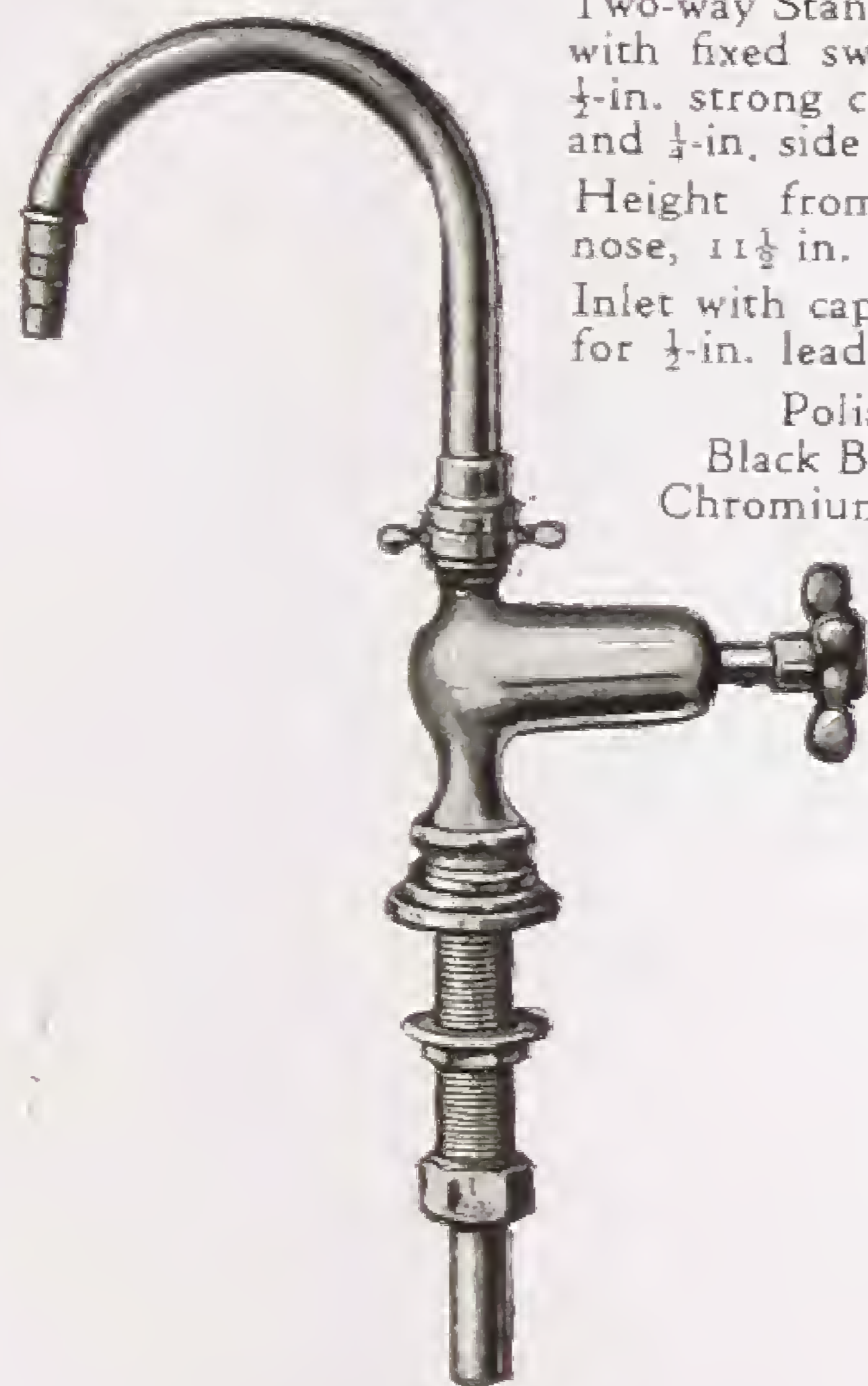

No. B 1024
Two-way Standard fitting, with fixed swan neck in $\frac{1}{2}$ -in. strong copper tube, and $\frac{1}{4}$ -in. side cock.

Height from base to nose, $11\frac{1}{2}$ in.

Inlet with cap and lining for $\frac{1}{2}$ -in. lead pipe.

Polished.
Black Bronzed
Chromium-plated.

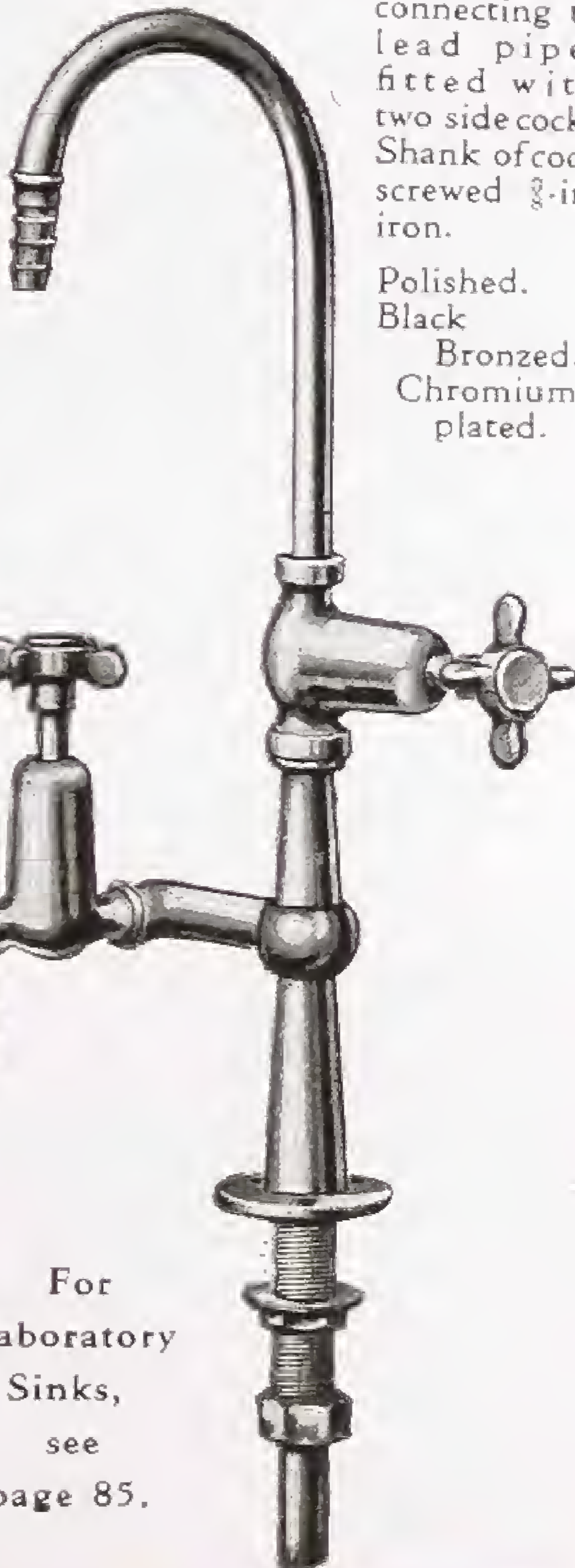

No. B 1026
One-way Standard fitting with loose swan neck in $\frac{1}{2}$ in. strong copper tube, and winged fly-nut, enabling it to be fixed in any position.

Height from base to nose, 6 in. Inlet with cap and lining for $\frac{1}{2}$ -in. lead pipe.

Polished. Black Bronzed. Chromium-plated.

For
Laboratory
Sinks,
see
page 85.

BAXENDALE & CO. LTD.

STOP TAPS

B.S. 1010 Pattern.



No. B 330.
STOP TAP

Lead to lead. Rough body.



No. B 312
STOP TAP

Male and Female.



No. B 310
STOP TAP

Female both ends.

All above stocked in Sizes $\frac{1}{2}$ $\frac{3}{4}$ 1 $1\frac{1}{4}$ $1\frac{1}{2}$ 2 in.



No. B 266
UNDERGROUND STOP TAP

Double union. Rough body.
Special Dublin Pattern.

Sizes $\frac{1}{2}$ $\frac{3}{4}$ in.



No. B 313
STOP TAP

Polished smooth body with indexed
capstan head.

Female both ends.

Sizes $\frac{1}{2}$ $\frac{3}{4}$ in.



No. B 314
STOP TAP

For iron cisterns.
Fixed valve.
Screwed inlet and
backnut.

Sizes : $\frac{1}{2}$ $\frac{3}{4}$ 1 in.



No. B 316
STOP TAP

Male, with union for lead.

Sizes : $\frac{1}{2}$ $\frac{3}{4}$ 1 in.



No. B 315
STOP TAP

Screwed inlet and
plain tail.

Sizes : $\frac{1}{2}$ $\frac{3}{4}$ 1 in.

MILLER STREET · MANCHESTER

STOP TAPS AND FERRULES

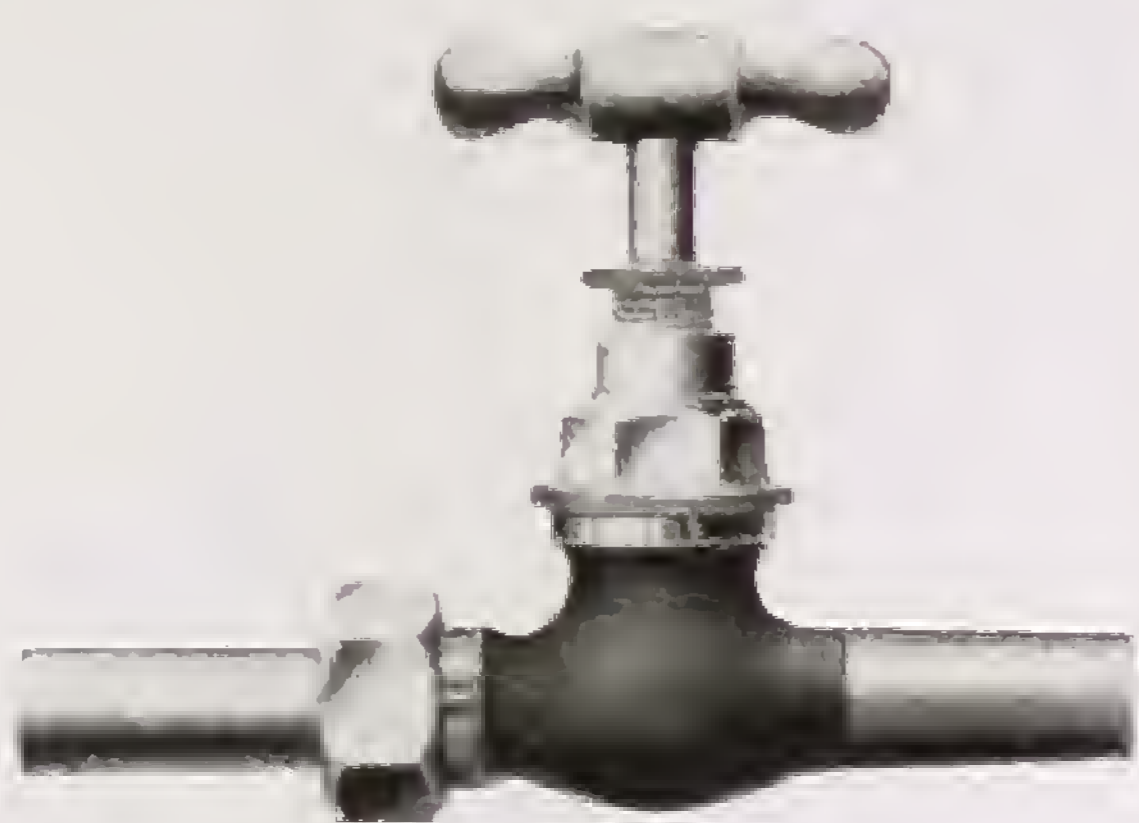

No. B 317
STOP TAP
 Union and plain tail
 for lead.
 BS.1010 pattern.
 Sizes : $\frac{1}{2}$ in., $\frac{3}{4}$ in., 1 in.

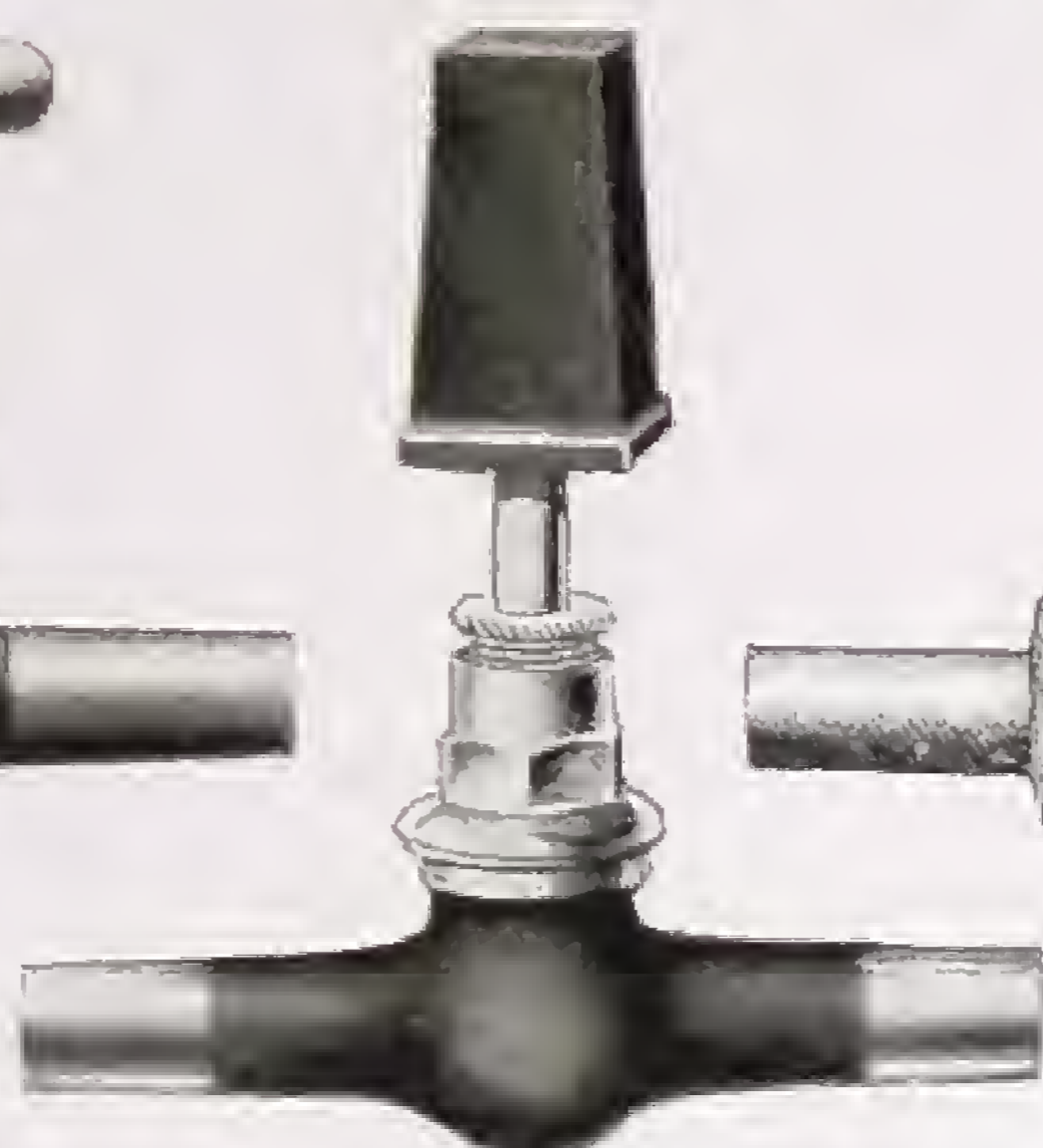

No. B 319. **STOP TAP**
 Lead to lead, rough body and cast-iron
 square head.
 BS.1010 pattern.
 All sizes : $\frac{1}{2}$ in. to 2 in.



No. B 318
STOP TAP
 With union for lead
 both ends.
 BS.1010 pattern.
 Sizes : $\frac{1}{2}$ in., $\frac{3}{4}$ in., 1 in

**FERRULE GUARD
 and LOOSE KEY**

Can be supplied with
 any screw-down bib or
 stop tap listed. (Extra.)

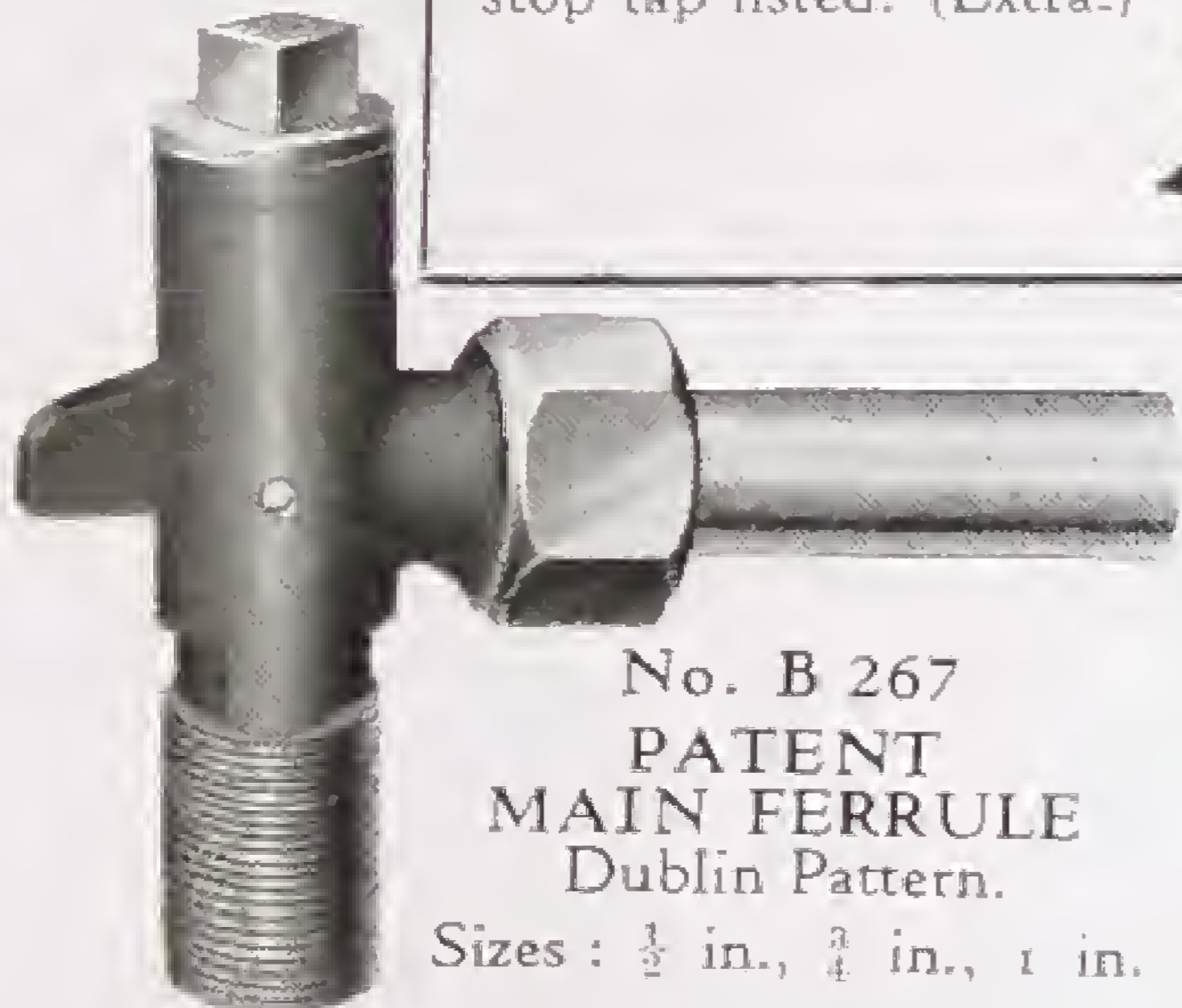

No. B 267
**PATENT
 MAIN FERRULE**
 Dublin Pattern.
 Sizes : $\frac{1}{2}$ in., $\frac{3}{4}$ in., 1 in.

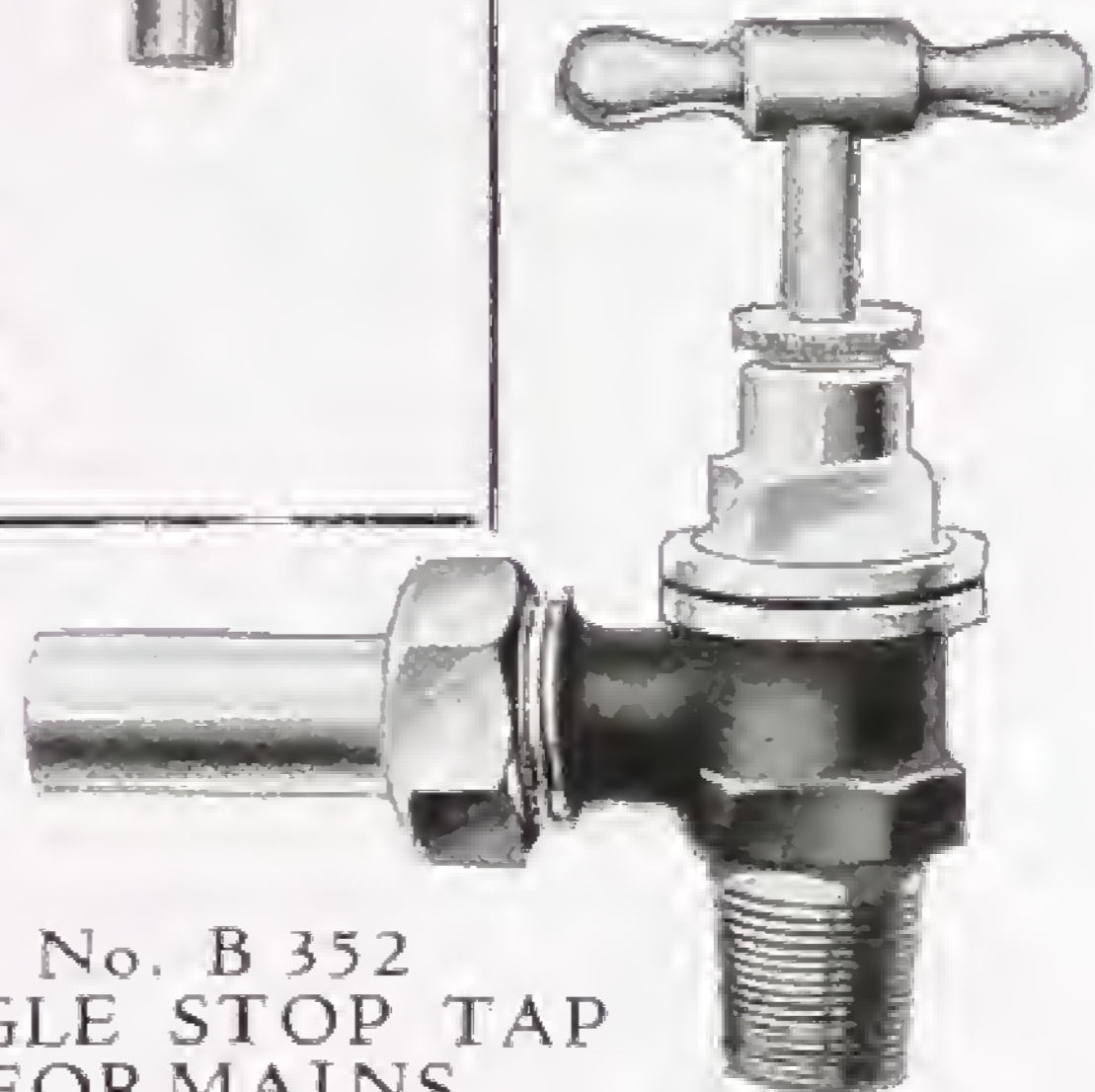

No. B 352
**ANGLE STOP TAP
 FOR MAINS**
 Taper male inlet and
 union for lead
 Sizes : $\frac{1}{2}$ in., $\frac{3}{4}$ in., 1 in.

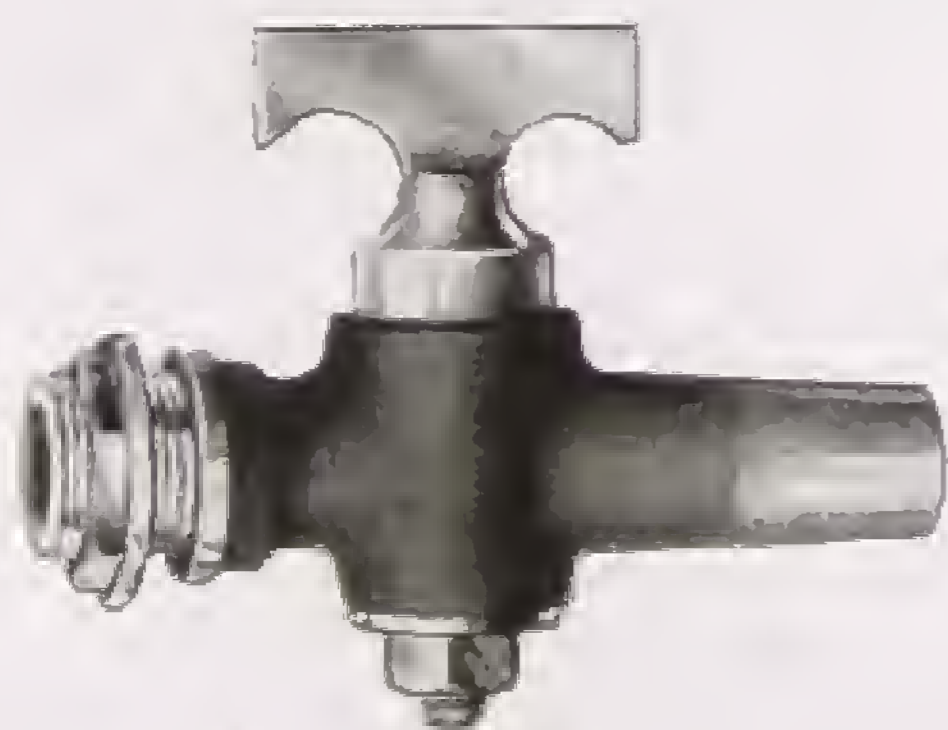

No. B 670
PLUG STOP TAP
 For iron cisterns.
 Screwed inlet with
 backnut, and plain tail.
 Size: $\frac{3}{4}$ in., 1 in.



No. B 690
PLUG STOP TAP
 Lead to lead.
 Square head.
 Sizes : $\frac{1}{2}$ in., $\frac{3}{4}$ in., 1 in.



No. B 661
PLUG STOP TAP
 Lead to lead.
 Tee crutch.
 Sizes : $\frac{1}{2}$ in., $\frac{3}{4}$ in., 1 in.

STOP TAPS FOR COPPER

All screw-down taps to
B.S.S. 1010



**No. B 285
STOP TAP**
Copper to copper.
Yorkshire.
Sizes : $\frac{1}{2}$, $\frac{3}{4}$, 1 in.



**No. B 286
STOP TAP**
Copper to copper. Two
unions. Yorkshire.
All sizes : $\frac{1}{2}$ to 2 in.



**No. B 288
PLUG STOP TAP**
Male with backnut to
Copper. Yorkshire.
Sizes : $\frac{1}{2}$, $\frac{3}{4}$ in.



**No. B 287
STOP TAP**
Male to copper.
Yorkshire.
Sizes : $\frac{1}{2}$, $\frac{3}{4}$, 1 in.



**No. B 289
STOP TAP**
Lead to copper.
Yorkshire.
Sizes : $\frac{1}{2}$, $\frac{3}{4}$, 1 in.



**No. B 290
STOP TAP**
Copper to copper union.
Yorkshire.
Sizes : $\frac{1}{2}$, $\frac{3}{4}$, 1 in.



**No. B 291
STOP TAP**
Lead to copper union. Yorkshire.
All sizes : $\frac{1}{2}$ to 2 in.

WE HOLD STOCKS of the following COPPER TUBE FITTINGS
at our various establishments—
CONEX, IDEAL, INSTANTOR, KONTITE, PRESTEX, SECUREX,
YORKSHIRE.
Illustrated brochures will be supplied on request.

STOP TAPS FOR COPPER

All screw-down taps to
B.S.S. 1010



**No. B 292
PLUG STOP TAP**
Copper to copper.
Yorkshire.
Sizes : $\frac{1}{2}$, $\frac{3}{4}$ in.

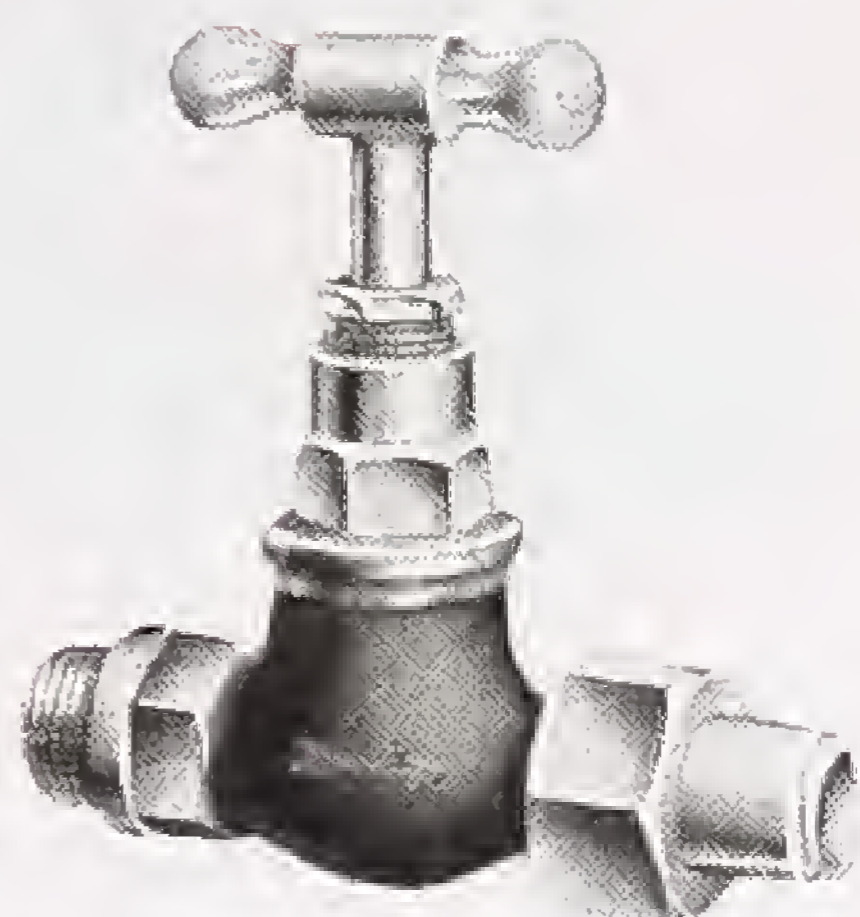

**No. B 293
STOP TAP**
Male to copper union.
Yorkshire
All sizes : $\frac{1}{2}$ to 2 in.

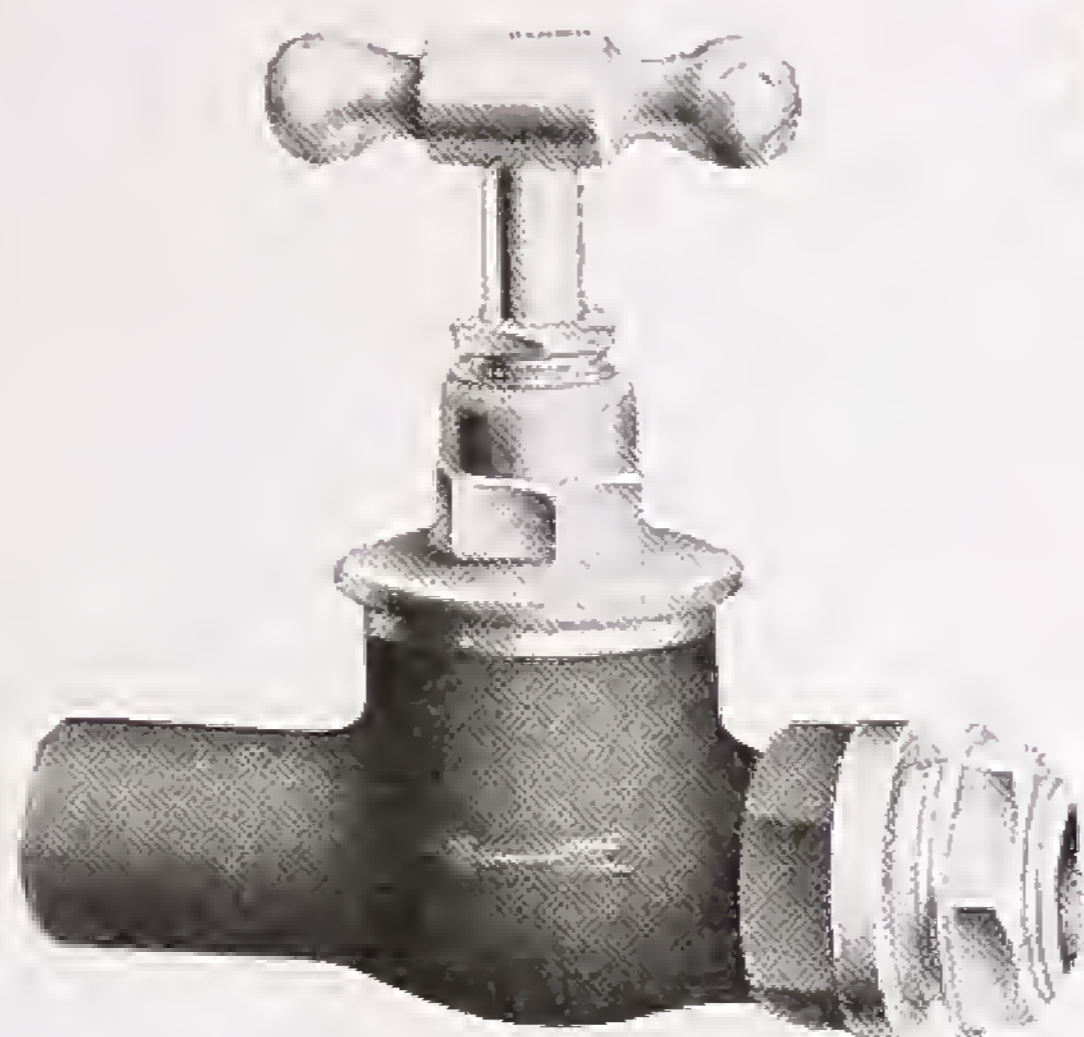

**No. B 294
CISTERN
STOP TAP**
Male with backnut to
copper. Yorkshire.
Sizes : $\frac{1}{2}$, $\frac{3}{4}$, 1 in.



**No. B 295
FULLWAY VALVE**
Copper to copper.
Yorkshire.
All sizes : $\frac{1}{2}$ to 2 in.

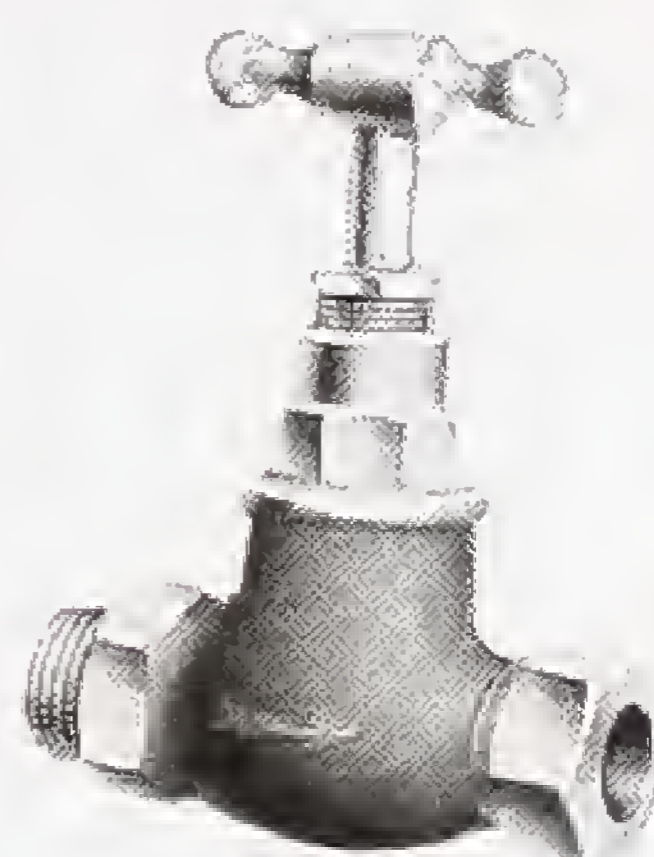

**No. B 296
STOP TAP**
Male to copper com-
pression joint.
All sizes : $\frac{1}{2}$ to 2 in.



**No. B 298
STOP TAP**
Copper to copper.
Compression joints.
All sizes : $\frac{1}{2}$ to 2 in.

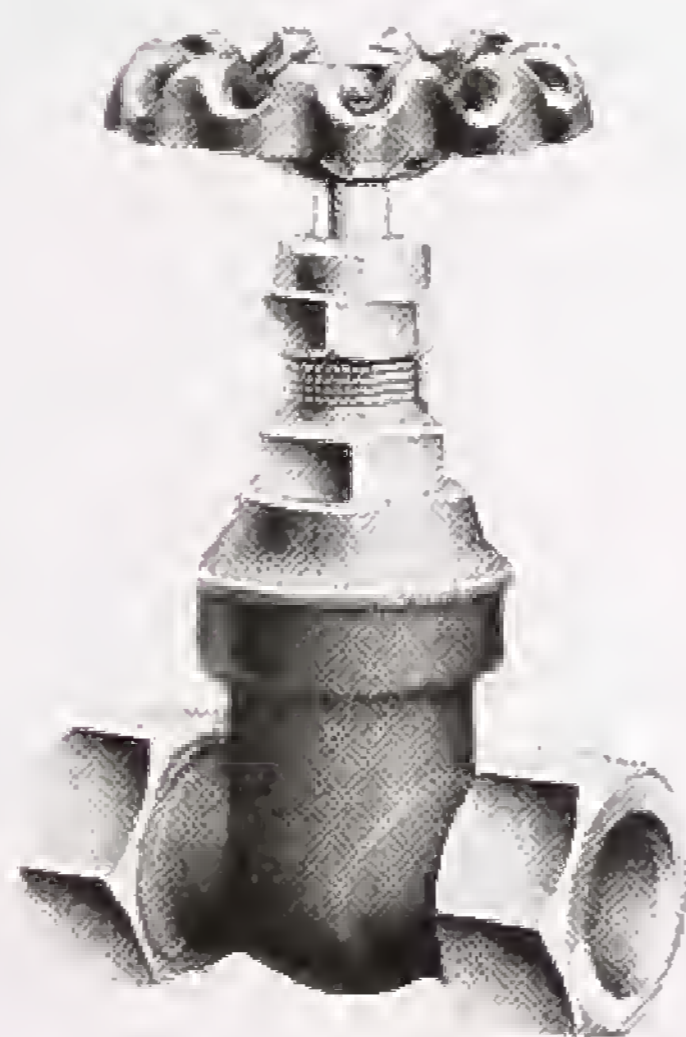

**No. B 297
FULLWAY VALVE**
Copper to copper
Compression joints.
All sizes : $\frac{1}{2}$ to 3 in.

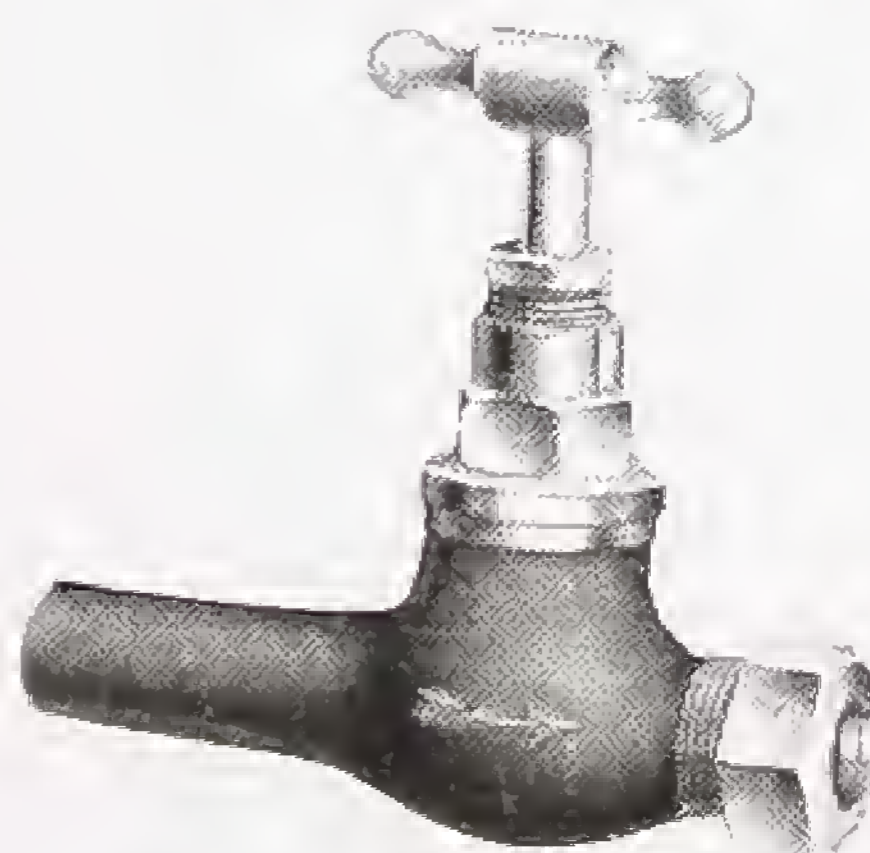

**No. B 299
STOP TAP**
Lead to copper.
Compression joint.
All sizes : $\frac{1}{2}$ to 2 in.

WE HOLD STOCKS of the following COPPER TUBE FITTINGS
at our various establishments—

CONEX, IDEAL, INSTANTOR, KONTITE, PRESTEX, SECUREX,
YORKSHIRE.

Illustrated brochures will be supplied on request.

BAXENDALE & CO. LTD.



No. B 657
SLUDGE COCK

With hose union and malleable iron loose key. Screwed male.
Sizes : $\frac{1}{2}$ in., $\frac{3}{4}$ in., 1 in.



No. B 658
SLUDGE COCK

Screwed male.
Sizes : $\frac{1}{2}$ in., $\frac{3}{4}$ in.

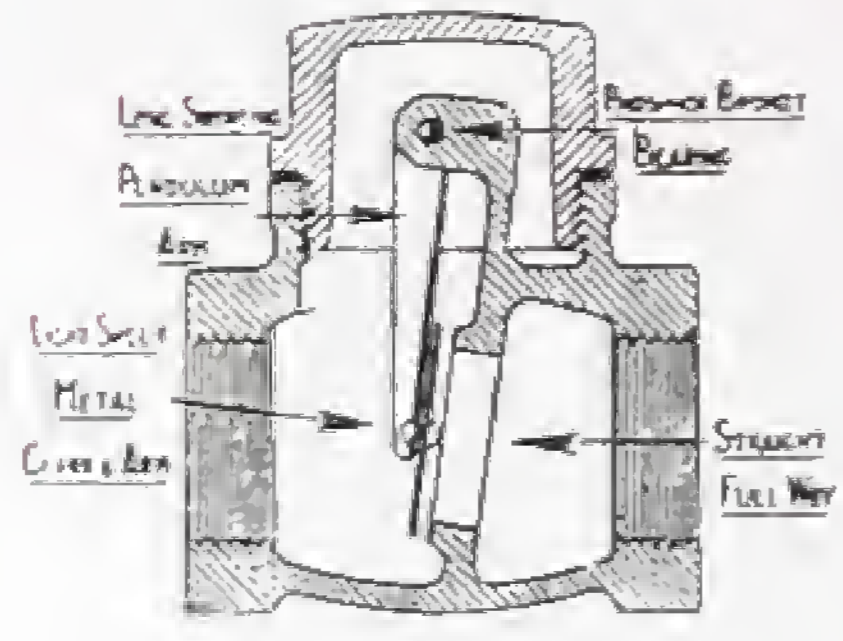

No. B 659
FEATHERWEIGHT BACK VALVE

For hot water supply. Female ends.
Does not check the circulatory movement of water. Should be fixed horizontally with a slight fall in the same direction as the pipe.
All sizes : $\frac{1}{2}$ in. to 2 in.



No. B 691
PRESSURE REDUCING VALVE

For water supply. Unions for lead pipe. Will effect any desired reduction of pressure not greater than one-half. State requirements when ordering.

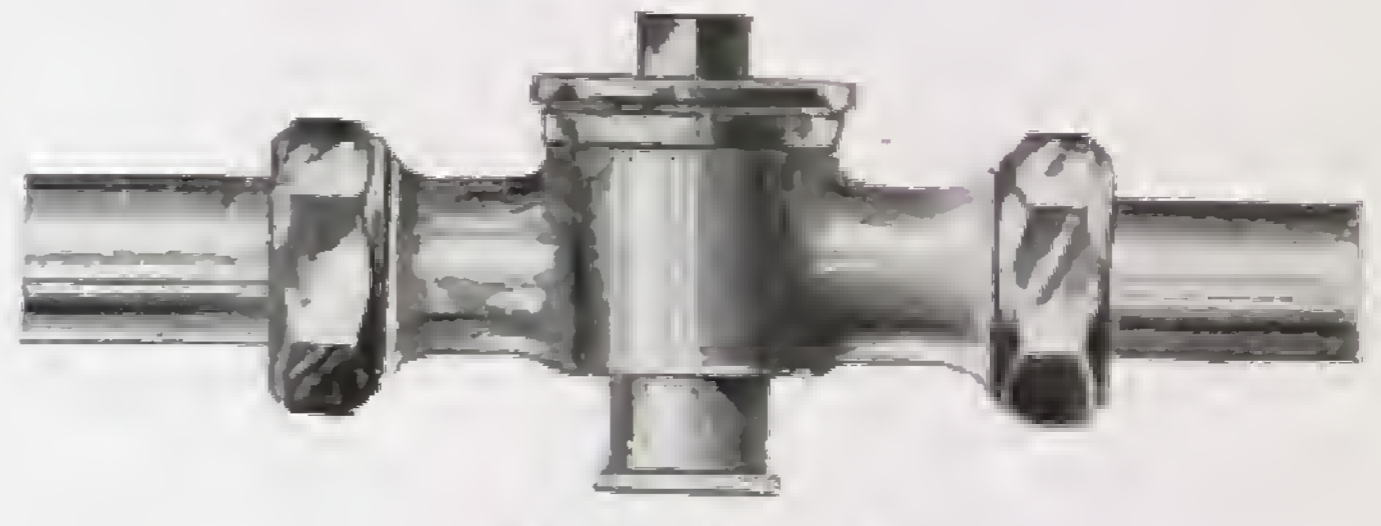

No. B 691

No. B 692
As above, but screwed female ends. (No unions.)
All sizes : $\frac{1}{2}$ in. to 1 $\frac{1}{2}$ in.

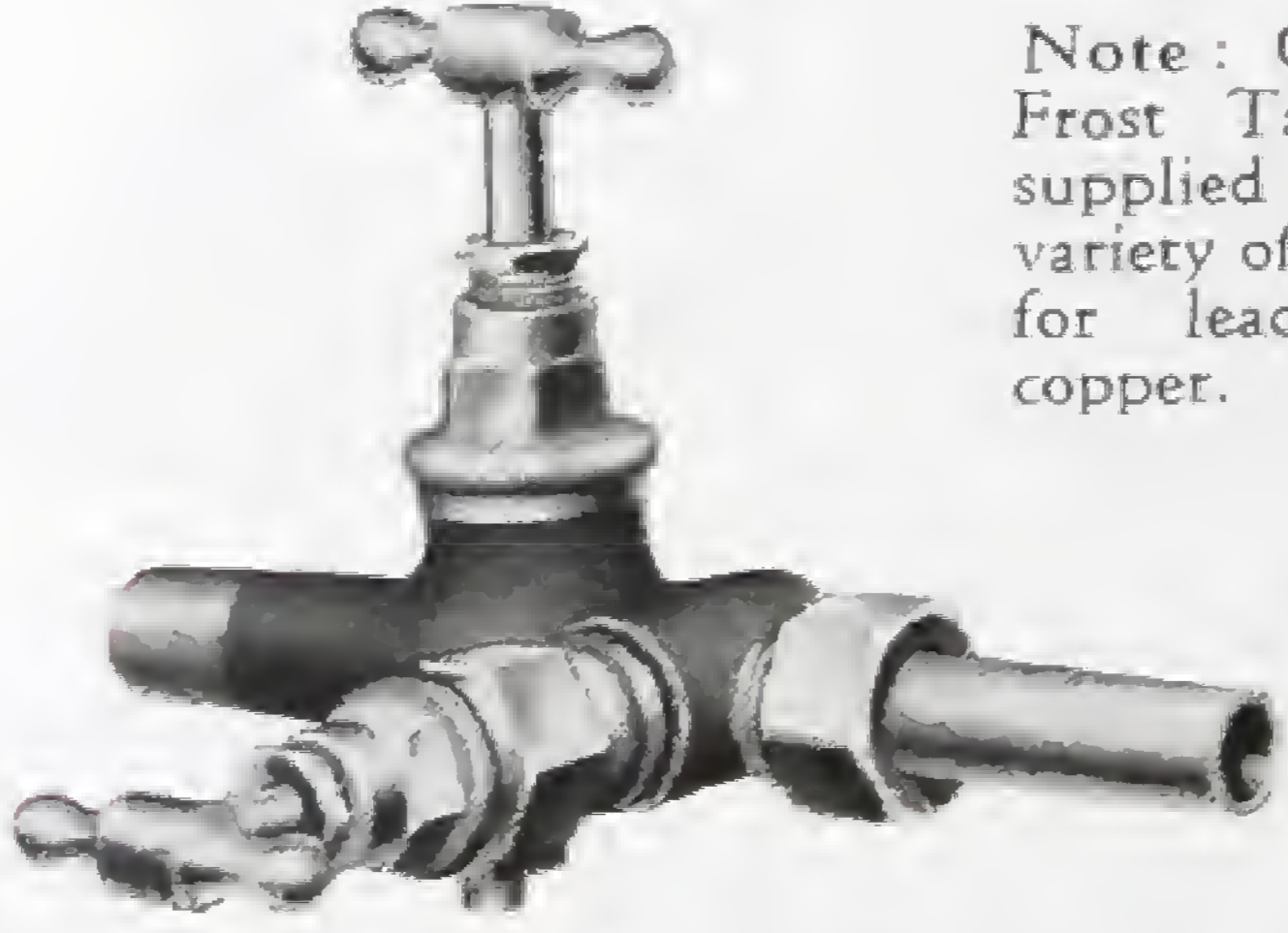

No. B 370
COMBINATION FROST TAP
BS.1010 pattern.

Plain tail \times union for lead with $\frac{1}{4}$ in. drain cock.
Size $\frac{1}{2}$ in.

Note : Combination Frost Taps can be supplied with a variety of connections for lead pipe or copper.

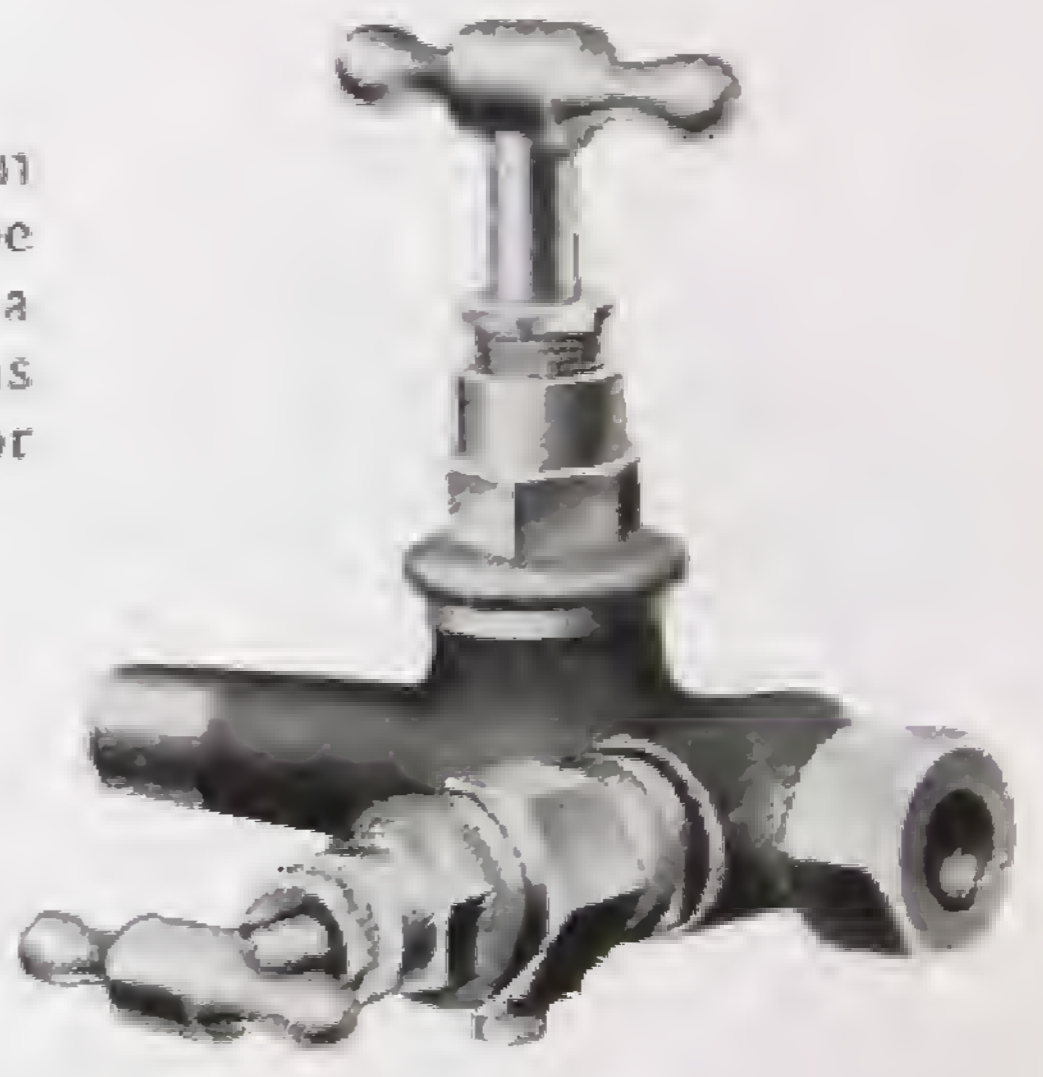

No. B 371
COMBINATION FROST TAP
BS.1010 pattern.

Plain tail \times compression joint for copper with $\frac{1}{4}$ in. drain cock.
Size $\frac{1}{2}$ in.

MILLER STREET · MANCHESTER



No. B 262

SUPATAP BIB TAP

Chromium-plated, screwed $\frac{1}{2}$ in. male iron. Normally supplied with metal ear pieces similar to the swan neck illustrated below, but De-Luxe ear pieces as this illustration can be supplied with all Supatap models at an extra charge.



No. B 263

SWAN NECK PILLAR TAP

Chromium-plated

$\frac{1}{2}$ in. size for lavatory basins, Model RT/A

$\frac{3}{4}$ in. size for baths, Model RT/B.



No. B 264

SINK PILLAR TAP

These give extra height, affording ample space for filling buckets, etc., in ordinary size sinks.

Model RT/EL. $\frac{1}{2}$ in. size, vertical clearance $4\frac{1}{2}$ in.

Model RT/LX. $\frac{1}{2}$ in. size, vertical clearance 2 in.

Model RT/B/EL. $\frac{3}{4}$ in. size, vertical clearance $4\frac{1}{2}$ in.

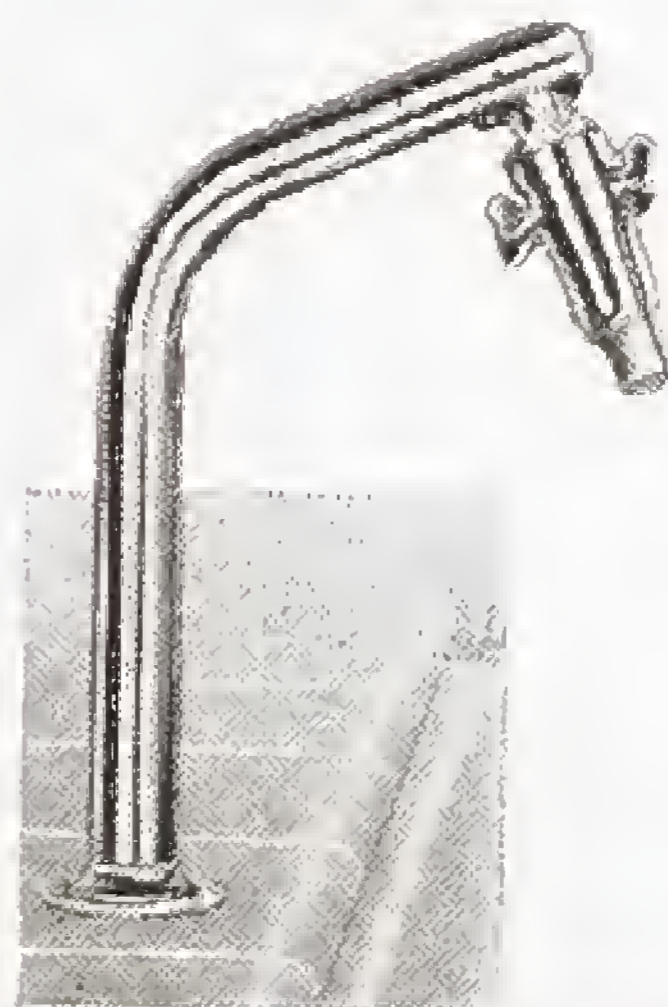

No. B 265

THE NEW CUSHIONED NYLON WASHER

This washer is extremely durable, as a result of a combination of special nylon and selected rubber, one material giving great toughness and the other a soft cushioning effect. This washer will last five times as long in Supataps as the standard pattern.





No. B 269

BIB TAP AND WALL PLATE

B.S. 1010 Pattern

Chromium-plated smooth-body with capstan head, indexed.

Wall plate with plain tail for lead.

Sizes : $\frac{1}{2}$ in. and $\frac{3}{4}$ in.



No. B 268

BIB TAP AND WALL PLATE

B.S. 1010 Pattern

Chromium-plated smooth-body with capstan head, indexed.

Wall plate with union tail for lead.

Sizes : $\frac{1}{2}$ in. and $\frac{3}{4}$ in.



No. B 261

BIB TAP STANDARD

Chromium-plated $4\frac{3}{4}$ in. or 6 in. high.

3 in. Screwed Tail and Back Nut.

Sizes : $\frac{1}{2}$ in. and $\frac{3}{4}$ in.

Can also be supplied with 12 in. or 17 in. tails (extra).



SINK TAPS



No. B 419

HIGH NECK SINK PILLAR TAPS

Chromium-plated BS1010 with solid capstan heads lettered H and C. 3 in. long tails supplied as standard but can also be supplied with extended tails as required.

Size $\frac{1}{2}$ in, with 4 in. nose and 4 in. neck.

Unions for lead can be supplied. (Extra).



No. B 417

"FIX-A-TAP" RUBBER JOINTING SET FOR FIXING BASIN TAPS AND WASTES

Each set comprises two "Fix-a-Tap" plugs, four rubber washers, two zinc or brass washers for taps, two rubber washers and one zinc or brass washer for waste.

The line drawing shows the method of fixing.

Full instructions are enclosed with each set.

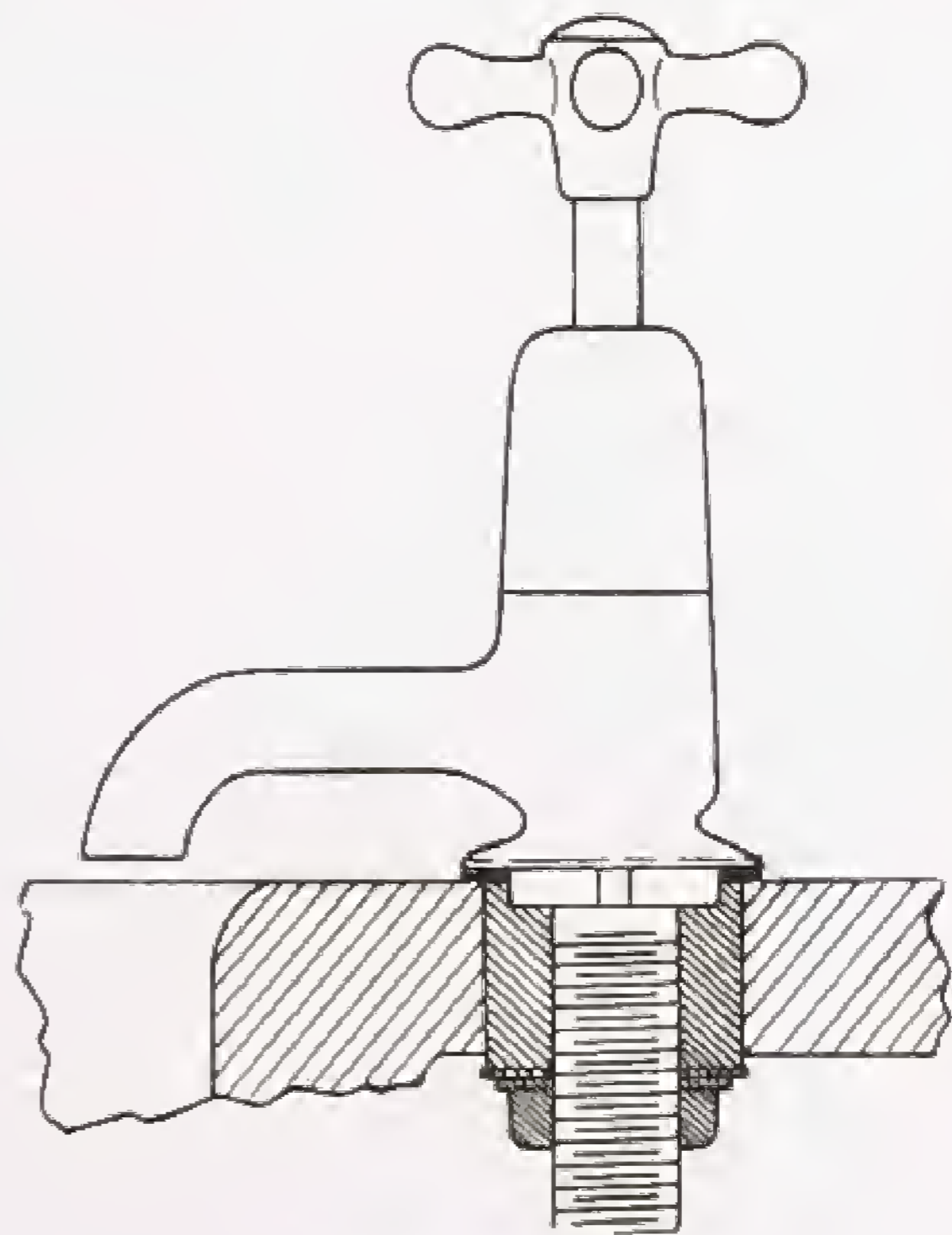

SINK FITTINGS



For other types of sink wastes and traps, see Page 149.



No. B 382 SET

Comprising $\frac{1}{2}$ in. No. B 236 chromium-plated hot and cold BS 1010 bib taps for iron, $1\frac{1}{4}$ in. B 805 chromium-plated sink waste with union, plug, and 17 in. chain.

LAVATORY FITTINGS

*For other types of
Lavatory wastes
with traps, see
Page 144.*

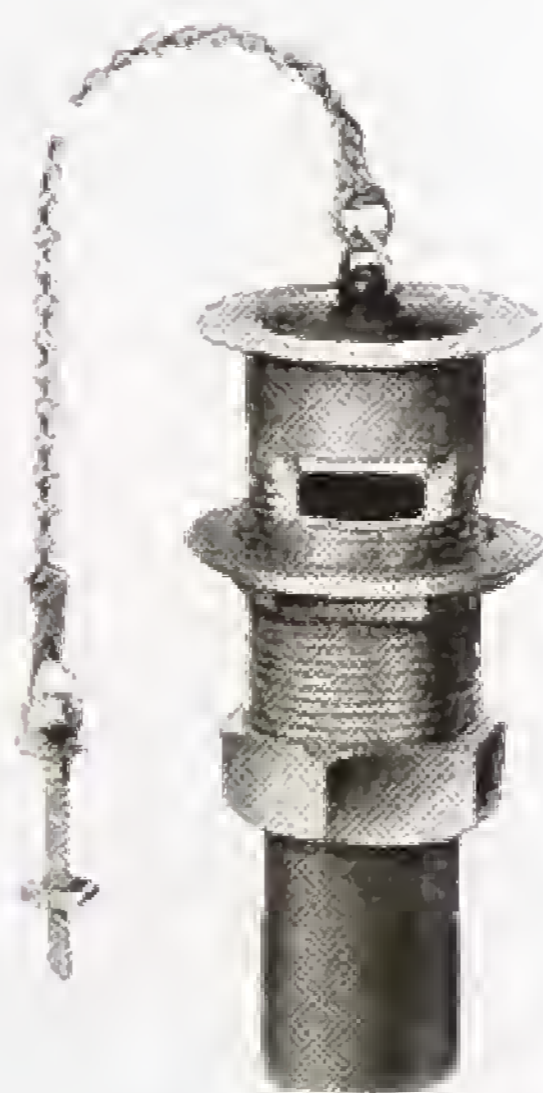

No. B 383 SET

Comprising $\frac{1}{2}$ in. No. B 418 chromium-plated hot and cold BS 1010 pillar taps with backnuts and unions for lead pipe, $1\frac{1}{4}$ in. No B 761 chromium-plated lavatory waste with union, black plastic plug, chain, and stay.

PILLAR BATH FITTINGS



Bath wastes with various types of traps are illustrated in more detail on Page 143.



No. B 386 SET

Comprising $\frac{3}{4}$ in. No. B 454 chromium-plated hot and cold BS 1010 pillar taps with backnuts and unions for lead pipe, $1\frac{1}{4}$ in. No. B 786 chromium-plated overflow and chain, $1\frac{1}{4}$ in. No. B 783 chromium-plated bath waste with black plastic plug and trap for lead.

GLOBE BATH FITTINGS

Bath wastes with various types of traps are illustrated in more detail on Page 143.

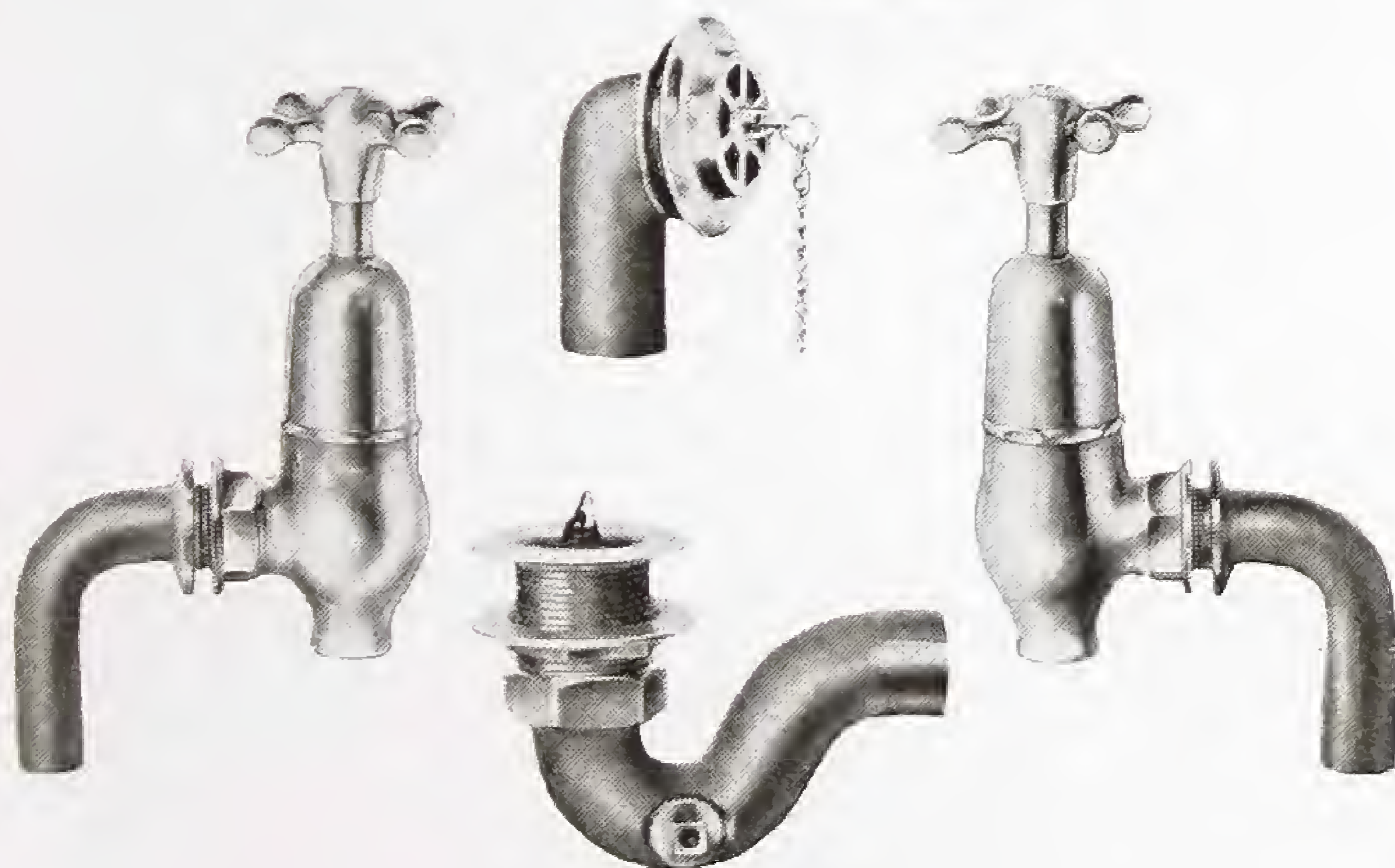
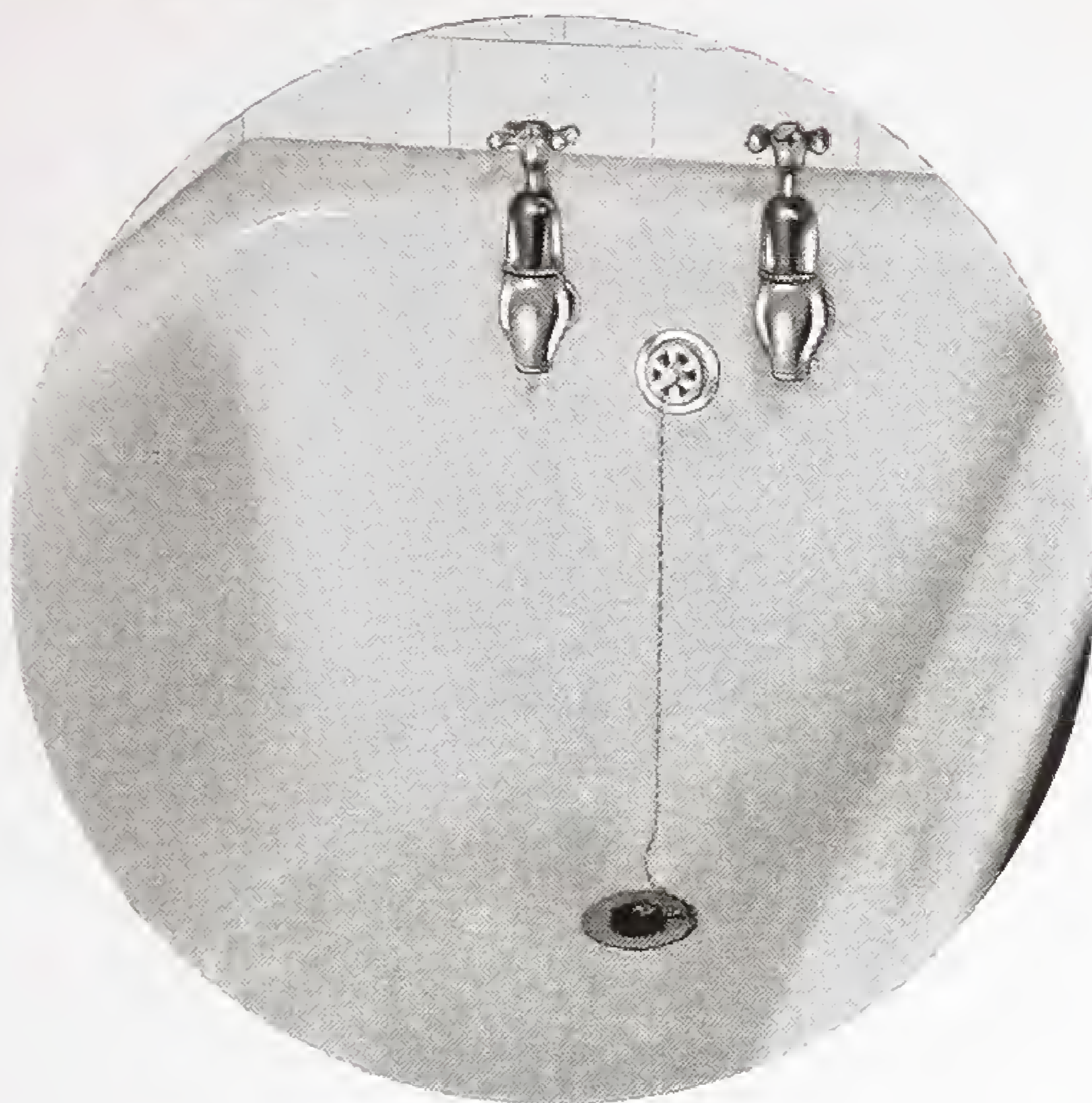

No. B 367 SET

Comprising $\frac{3}{4}$ in. No. B 456 chromium-plated hot and cold BS 1010 globe bath taps with bent ferrules, $1\frac{1}{4}$ in. No. B 786 chromium-plated bath overflow with chain, $1\frac{1}{4}$ in. No. B 783 chromium-plated bath waste with black plastic plug and trap for lead.

BATH AND LAVATORY TAPS



No. B 418

PILLAR LAVATORY TAP

Chromium-plated with indexed capstan head, to B.S.1010 Specification, supplied either with or without cap and tail for lead; also supplied with long thread for fireclay lavatories.

Extra.

Size $\frac{1}{2}$ in.

No. B 454

PILLAR BATH TAP

As above, but $\frac{3}{4}$ in. size.



No. B 622

HEXAGONAL PILLAR LAVATORY TAP

Chromium-plated with indexed capstan head, to B.S.1010 Specification. Can be supplied with or without cap and tail for lead.

Size $\frac{1}{2}$ in.

No. B 623

HEXAGONAL PILLAR BATH TAP

As above, but $\frac{3}{4}$ in. size.



No. B 626

SELF-CLOSING PILLAR LAVATORY TAP

Non-concussive push button operation, chromium-plated finish. Supplied with or without cap and tail for lead.

Size $\frac{1}{2}$ in.

No. B 611

SELF-CLOSING PILLAR LAVATORY TAP

The famous 'G & K' non-concussive pattern with push-button operation, supplied in polished brass or chromium plated finish, with or without cap and tail for lead.

Size $\frac{1}{2}$ in.



If possible please give approximate water pressure when ordering Self-closing Taps.

BATH FITTINGS



No. B 456
GLOBE BATH TAP
BS 1010 pattern with
Capstan head, indexed.
Tail for lead.
Size $\frac{3}{4}$ in.



No. B 847
**TAPHOLE
STOPPER**

For baths and lavatories.
Dia. of flange, $1\frac{1}{8}$ in.



No. B 848
**OVERFLOW
STOPPER**

For baths, with chain ring.
Dia. of flange, $2\frac{1}{2}$ in.



No. B 786
**ROUND BATH
OVERFLOW**
Size : $1\frac{1}{4}$ in.

ALL FITTINGS
ILLUSTRATED
ON THIS PAGE
ARE SUPPLIED
CHROMIUM-
PLATED
UNLESS ORDERED
OTHERWISE.

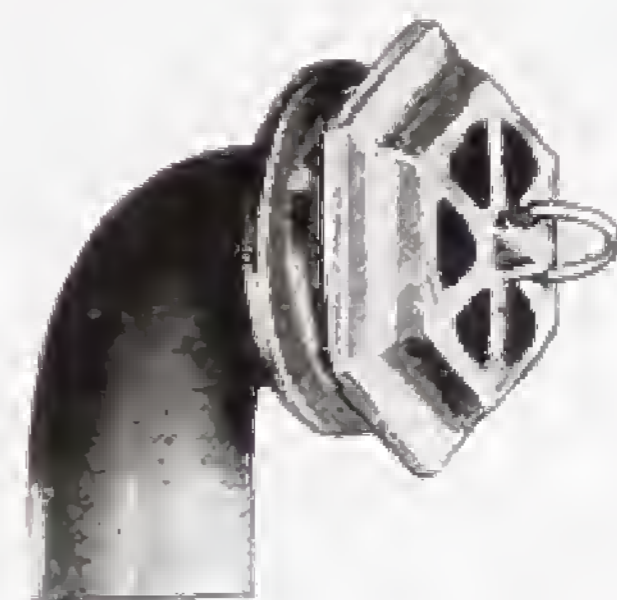

No. B 759
**HEXAGONAL BATH
OVERFLOW**
Size : $1\frac{1}{4}$ in.



No. B 783
BATH WASTE
Black plastic plug.
Trap for lead pipe with
access cap.
Sizes : $1\frac{1}{4}$ in., $1\frac{1}{2}$ in., 2 in.



No. B 781
BATH WASTE
Black plastic plug.
Bent union for lead pipe.
Sizes : $1\frac{1}{4}$ in., $1\frac{1}{2}$ in.

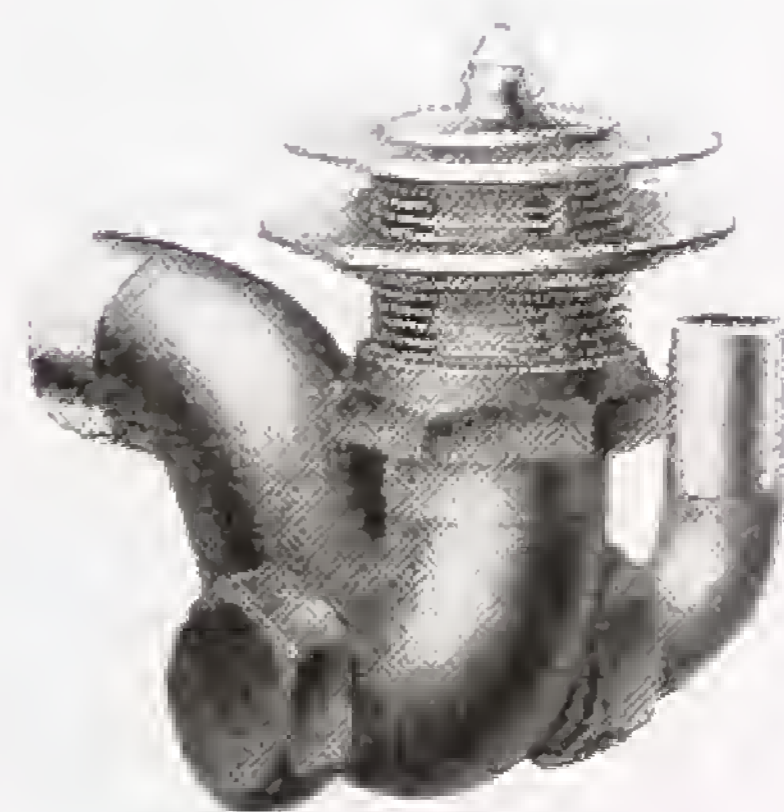

No. B 799
BATH WASTE
Black plastic plug.
Brass trap and access cap.
Bent overflow union
at side.
(Cap and union
interchangeable.)
Sizes : $1\frac{1}{4}$ in., $1\frac{1}{2}$ in., 2 in.

LAVATORY WASTES



No. B 760

LAVATORY WASTE

With backnut and straight union.
No overflow slot.
Black plastic plug.
Sizes : 1, 1½ in.

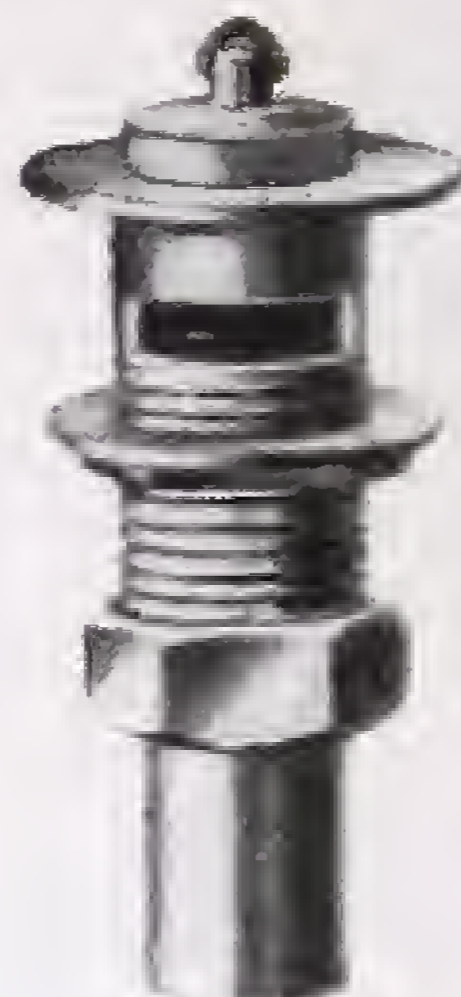

No. B 761

LAVATORY WASTE

With backnut and straight union, and overflow slot.
Black plastic plug.
Sizes : 1, 1½ in.



No. B 774
TRAPPED LAVATORY WASTE

With or without overflow slot.
Black plastic plug.
Rough brass P trap with access cap

No. B 775
LAVATORY WASTE

As above, but with S trap.
Size : 1½ in.

All Lavatory Wastes are supplied with 2⁷/₁₆ in. Flange and are sent out chromium-plated unless ordered otherwise.



No. B 826

DRAWN COPPER TRAP

Swivel Type

P or S with outlet for lead or copper, 3 in. seal.

Sizes : 1½ in., 1¾ in.

Supplied in unpolished copper unless otherwise specified.



No. B 827
LAVATORY WASTE

With chromium-plated bottle trap and detachable Black Polythene acid-resisting base ; outlet for copper, or can be supplied with tail for lead.

Size : 1½ in., 1¾ in. seal.

SINK AND TUB WASTES



**No. B 804
SINK WASTE**
With backnut and
straight union.
No overflow slot.
Black plastic plug.
Sizes : 1 1/4 in., 1 1/2 in., 2 in.



**No. B 805
SINK WASTE**
With back nut and
straight union.
With overflow slot.
Black plastic plug.
Sizes : 1 1/4 in., 1 1/2 in., 2 in.



**No. B 955
SINK WASTE**
With flush grating.
With backnut and
straight union.
Sizes : 1 1/2 in., 2 in.



**No. B 809
SINK WASTE**
Stamped brass type
with centre screw.
Size 2 in.



**No. B 772
BLACK PLASTIC
PLUG**
Sizes : 1 in. to 2 1/2 in.



**No. B 810
TUB PLUG AND
SOCKET**
For wash tubs.
With backnut.
Size 2 in.



**No. B 773
RUBBER PLUG**
Sizes : 1 in. to 2 1/2 in.



**No. B 778
TRAPPED SINK
WASTE**
With or without
overflow slot.
Black plastic plug.
Rough brass S trap
with access cap.
Sizes : 1 1/4 in., 1 1/2 in., 2 in.

*All sink wastes stocked
with 3 3/8-in. flange, but
any other size will be
supplied specially.*

**No. B 779
TRAPPED SINK
WASTE**
With or without
overflow slot.
Black plastic plug.
Rough brass P trap
with access cap.
Sizes : 1 1/4 in., 1 1/2 in., 2 in.

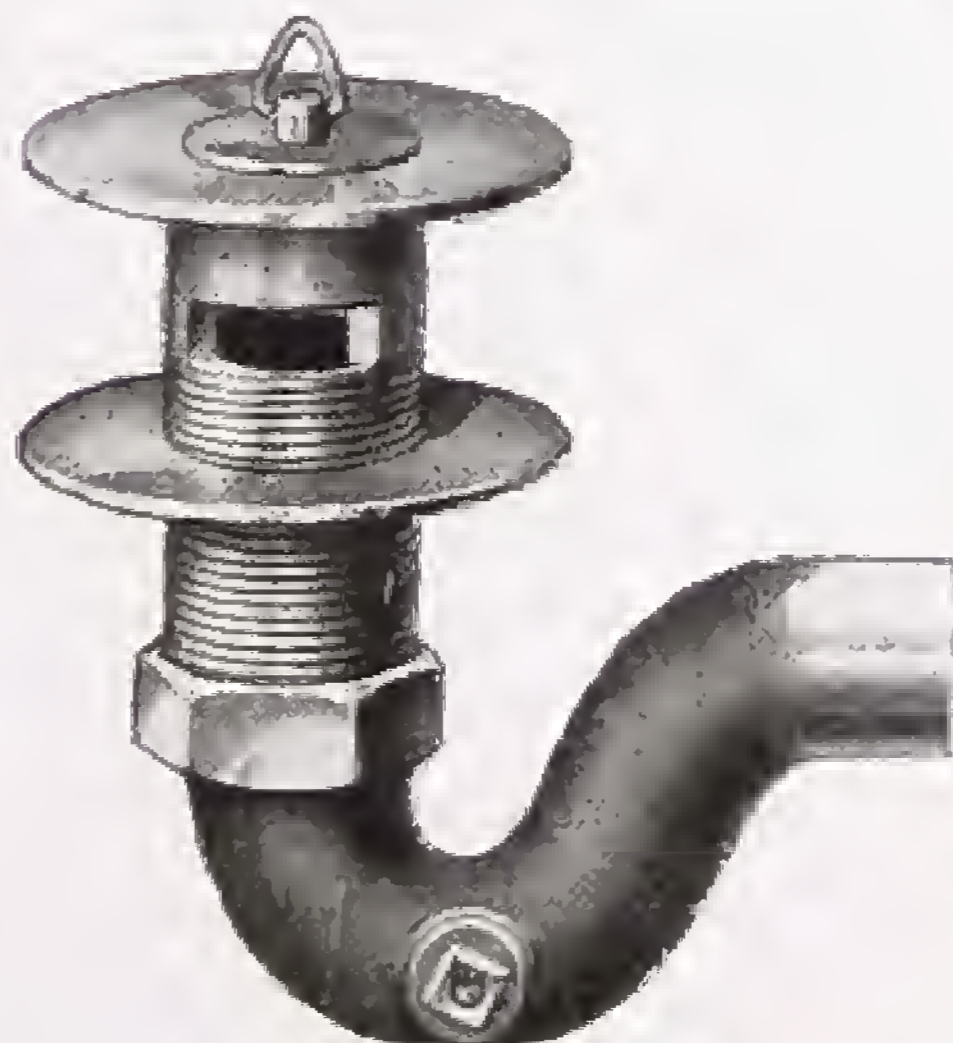

All above supplied with Chromium-Plated Flanges unless ordered otherwise.



No. B 879

COLEMAN'S CONNECTION

FOR CYLINDERS, TANKS, CISTERNS, Etc.

The fitting is inserted through an oval hole, which can be easily cut with a "Curvicut" Hack Saw.

Curved for cylinders. Flat for tanks. Screwed female. Galvanized or Brass.

These connections are sent out complete with Template and Rubber Washer, also full instructions for fixing.

Sizes : $\frac{1}{2}$, $\frac{3}{4}$, 1, $1\frac{1}{4}$, $1\frac{1}{2}$, 2, $2\frac{1}{4}$, $2\frac{1}{2}$ in.

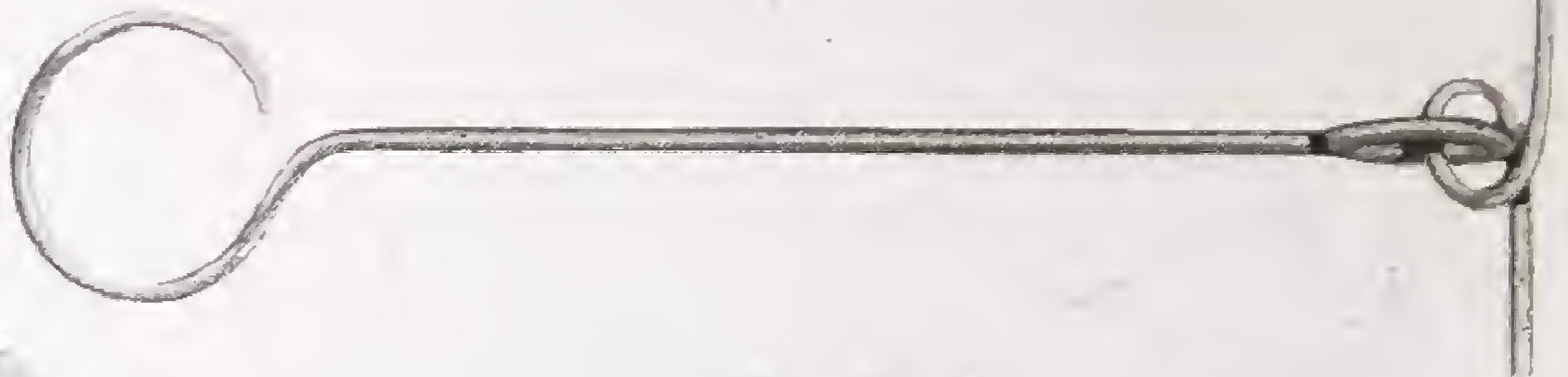

No. B 812

THE ESSEX CONNECTION FOR CYLINDERS, STORAGE TANKS, etc.



The only preparation necessary to fit the "Essex" flange is to drill or cut one round hole to the required size. The flange is fitted entirely from the outside of the cylinder or tank and each set includes a special tool, as illustrated. The "Essex" flange has a brass body and nut and brass and rubber washers.

Fig. E1 for flat surfaces, screwed $\frac{1}{2}$, $\frac{3}{4}$, 1, $1\frac{1}{4}$, $1\frac{1}{2}$, 2, $2\frac{1}{4}$ in.

Fig. E2 for curved surfaces, screwed $1\frac{1}{2}$, 2, $2\frac{1}{4}$ in.

Fig. E3 for inclined surfaces, screwed 2, $2\frac{1}{4}$ in.



No. B 881

No. B 882

No. B 883

No. B 887

No. B 891

No. B 890

BRASS FERRULES, Etc.

	Size	$\frac{1}{2}$ in.	$\frac{3}{4}$ in.	1 in.	$1\frac{1}{4}$ in.	$1\frac{1}{2}$ in.	2 in.
B 881. Single Nut Tank Ferrule	*	*	*	-	-	-
B 882. Double	*	*	*	*	*	*
B 883. As B 881 with $1\frac{1}{2}$ in. thread	*	*	*	*	*	*
B 887. Bent Single Nut Ferrule	*	*	*	-	-	-
B 888. " " " Long Thread	*	*	*	-	-	-
B 890. Straight Cap and Lining	*	*	*	*	*	*
B 891. Bent " " "	*	*	*	*	*	*

N.B. Sizes available are denoted with an asterisk

BAXENDALE & CO. LTD.



No. B 841
ROUND BOSS



No. B 857
TRAP SCREW

B 841. Round boss to BSS. 1010, brass or chromium-plated, sizes : $\frac{1}{2}$, $\frac{3}{4}$, 1 in.

B 857. Trap screw, brass, sizes : 1, 1 $\frac{1}{4}$, 1 $\frac{1}{2}$, 2, 2 $\frac{1}{2}$, 3 in.



No. B 865
STRAIGHT
BOILER
UNION

Hot-pressed
Light Pattern.
Male Iron to
Lead.

All sizes :
 $\frac{1}{2}$ in. to 2 in.



No. B 866 STRAIGHT BOILER UNION

Hot-pressed
Medium Pattern.
Male Iron to Lead.
Sizes : $\frac{1}{2}$ in., $\frac{3}{4}$ in., 1 in.

No. B 867
STRAIGHT
BOILER
UNION

Cast Brass.
Heavy Pattern.
Male Iron to
Lead.

All sizes :
 $\frac{1}{2}$ in. to 2 in.



No. B. 874
BENT BOILER
UNION

Hot-pressed
Medium Pattern.

Sizes : $\frac{1}{2}$ in., $\frac{3}{4}$ in., 1 in.



No. B 875
ELBOW MAIN
FERRULE

Cast Brass.
Heavy Pattern.

Male Iron and union
for lead pipe.

All sizes : $\frac{1}{2}$ in. to 1 $\frac{1}{2}$ in.



No. B 872
PLUMBERS'
UNION

Strong Pattern.

Lead to lead.

All sizes : $\frac{1}{2}$ in. to 2 in.



No. B 953. LENGTHENING SOCKET

Brass or chromium-plated, with male and female ends for iron.

$\frac{1}{2}$ in. \times 1 in. long

$\frac{1}{2}$ in. \times 1 $\frac{1}{2}$ in. ,,

$\frac{1}{2}$ in. \times 2 in. ,,

$\frac{1}{2}$ in. \times 3 in. ,,

$\frac{3}{4}$ in. \times 1 in. long

$\frac{3}{4}$ in. \times 1 $\frac{1}{2}$ in. ,,

$\frac{3}{4}$ in. \times 2 in. ,,

$\frac{3}{4}$ in. \times 3 in. ,,

BAXENDALE & CO. LTD.

BALL VALVES

No. B 907
 High Pressure
 BS1212 Ball Valve
 with backnut, union, and copper
 ball.



No. B 906
 High-pressure M.O.H. ball valve,
 with backnut, union, and copper
 ball.



No. B 902
 High-pressure Croydon ball valve,
 with backnut, union and copper
 ball.



No. B 904
 Low-pressure full bore ball valve,
 with backnut, union, and copper
 ball.

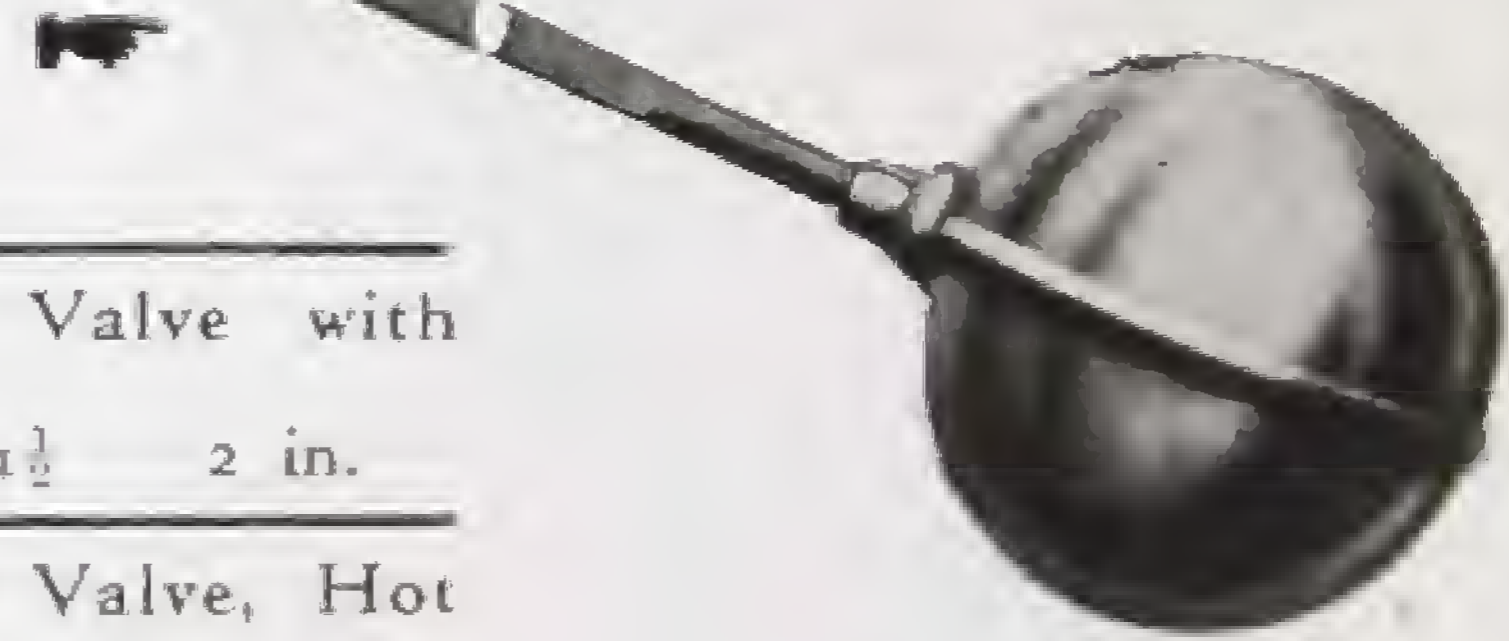

B907 BS1212 Hot Pressed Ball Valve with
 Renewable Seating

Sizes $\frac{3}{8}$ $\frac{1}{2}$ $\frac{3}{4}$ 1 $1\frac{1}{4}$ $1\frac{1}{2}$ 2 in.

B906 High Pressure M.O.H. Ball Valve, Hot
 Pressed or Cast Brass

Sizes $\frac{3}{8}$ $\frac{1}{2}$ $\frac{3}{4}$ in.

B 902
 High Pressure 'Croydon' Ball Valve
 Sizes $\frac{1}{2}$ $\frac{3}{4}$ 1 in.
 $\frac{1}{2}$ in. size Hot Pressed, Larger Sizes Cast
 Brass.

B904
 Low Pressure 'Portsmouth' Ball Valve
 Sizes $\frac{1}{2}$ $\frac{3}{4}$ 1 $1\frac{1}{4}$ $1\frac{1}{2}$ 2 in.
 $\frac{1}{2}$ in. and $\frac{3}{4}$ in. sizes Hot Pressed.
 Larger sizes cast brass.

SIZES OF COPPER BALLS REQUIRED FOR BALL VALVES

Size of ball valve	$\frac{3}{8}$	$\frac{1}{2}$	$\frac{3}{4}$	1	$1\frac{1}{4}$	$1\frac{1}{2}$	2 in.
Diameter of Copper Ball— BS.1212 ball valves...	$4\frac{1}{2}$	$4\frac{1}{2}$	6	8	10	10	12 in
M.o.H. and other types ...	$4\frac{1}{2}$	$4\frac{1}{2}$	6	$6\frac{1}{2}$	8	10	12 in.

Most ball valves can be supplied with a silence tube fitted in the outlet for a small extra charge.

MILLER STREET · MANCHESTER

BALL VALVES

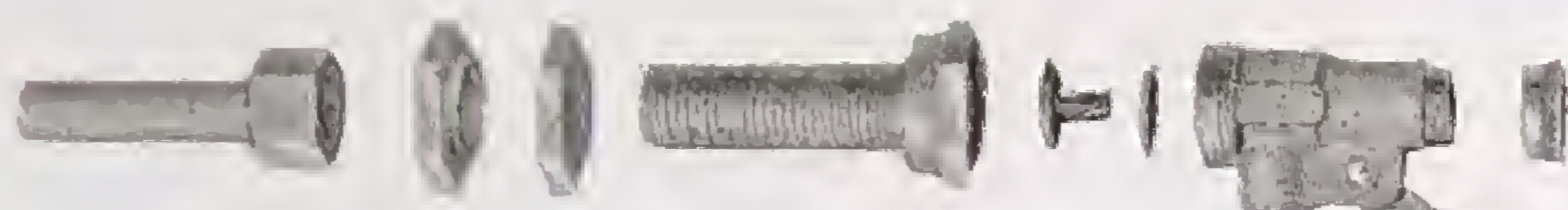

No. B.909

High Pressure BS.1212 Best Quality Cast Brass Ball Valve with detachable seating, cap over piston, backnut, union, and copper ball. Size $\frac{1}{2}$ in.

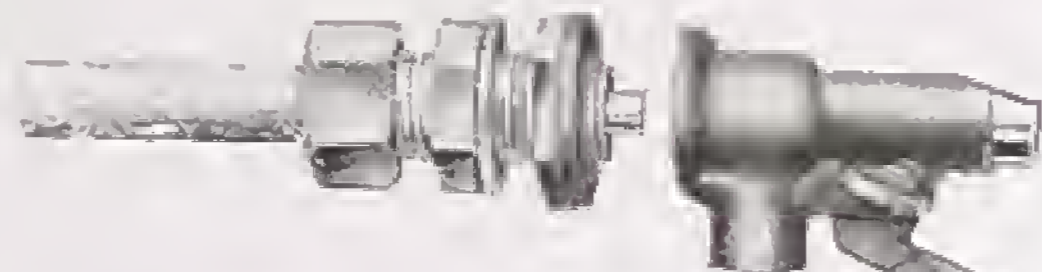
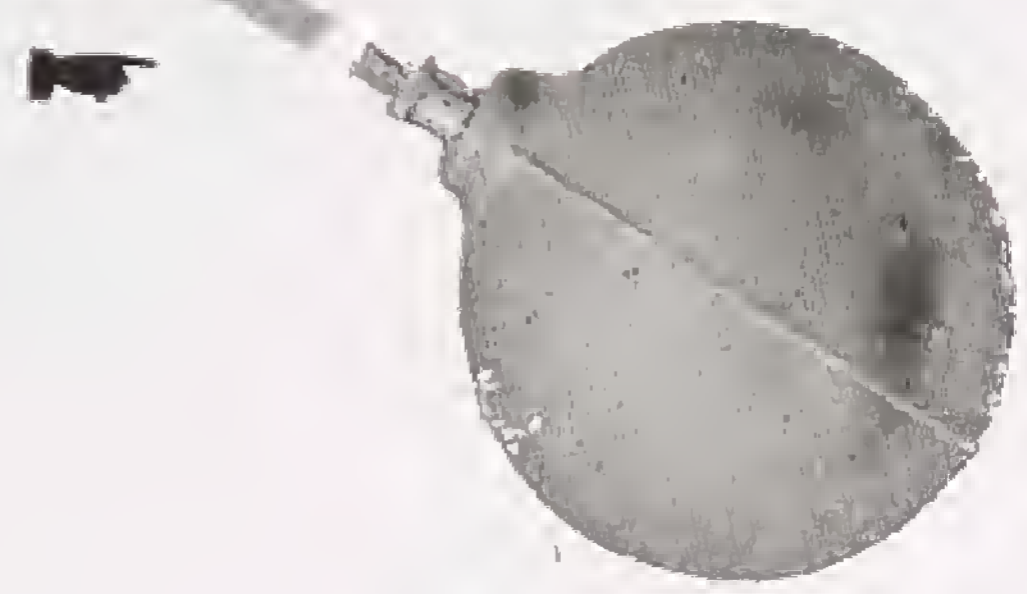

No. B 911

High-pressure Hot-pressed ball valve suitable for Newcastle-on-Tyne. With backnut, union, and copper ball.

Sizes $\frac{1}{2}$, $\frac{3}{4}$ in.



No. B 923

Fullway Equilibrium Ball Valve

Brass-body, gun metal sliding tube and working parts, brass lever and copper ball. With backnut and union.

Sizes $\frac{1}{2}$ $\frac{3}{4}$ 1 $1\frac{1}{4}$ $1\frac{1}{2}$ in.

Can be supplied in 2 in. size also with wrought iron lever.



No. B 925
FULLWAY
EQUILIBRIUM
FLOAT VALVE

Cast-iron body, brass sliding tube and working parts, wrought-iron lever and copper float. (3-in. size and over tinned.) Flanged inlet B.S.T.I. Machined across and drilled.

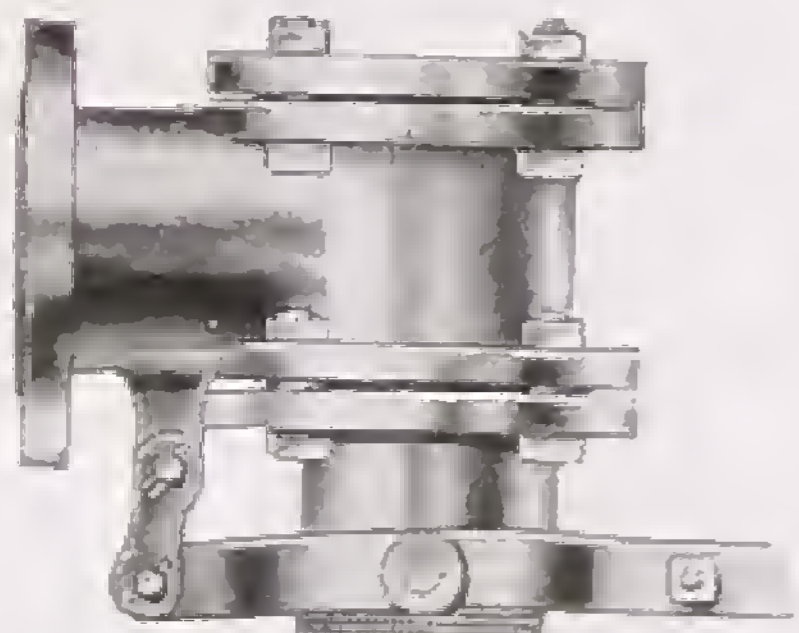

Sizes 2 $2\frac{1}{2}$ 3 4 5 6 in.

Can be supplied with a flange bolted on and screwed female for iron pipe. (Extra)

COPPER BALLS AND FLOATS, ETC.



No. B 930



No. B 931



No. B 932



No. B 933

COPPER BALLS AND FLOATS

COPPER BALLS

No. B 930	{	Soldered	All sizes 4 in. to 12 in. dia.
		Solderless	All sizes 4 in. to 6 in. dia.
		Brazed	All sizes 4 in. to 6 in. dia.

No. B 931 Flat Topped Copper Float with top nib, 4½ in.

No. B 932 Flat Topped Copper Float with side nib, 4½ in.

No. B 933 Domed Top Copper Float with side nib, 4½ in.



No. B 957

A.B.M. POLYTHENE FLOAT

Seamless Blown Pattern
With fully threaded internal brass boss; equal capacity to a 4½ in. spherical ball but of less diameter; complies with BSS.2456.



No. B 958

ONAZOTE EXPANDED RUBBER FLOAT

With brass threaded boss; unsinkable owing to its cellular structure.
Sizes: 4½ in. and 5 in.



No. B 934. BRASS BALL TAP LUG

For converting ball taps to suit wood cisterns.
Sizes: ½ in., ¾ in.

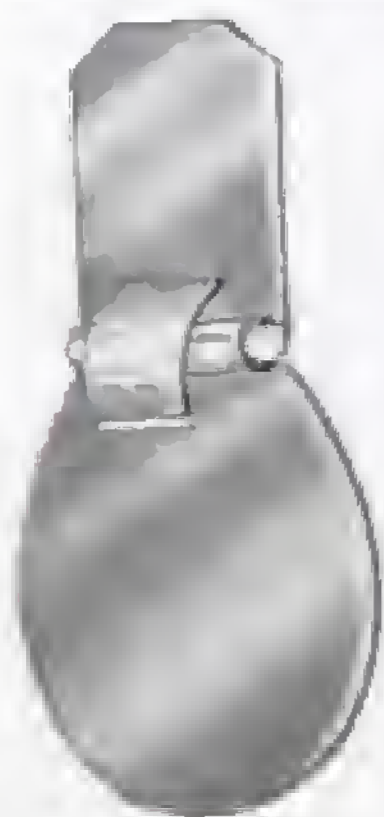

No. B 954. COPPER PIPE FLAP

Hinged

Sizes: ¾ in., 1 in., 1¼ in., 1½ in., 2 in.

No. B 853. ANTI-SPLASH TAP FILTER

Stamped pattern with clip.
Brass or Chromium-Plated.

Sizes: ½ in. and ¾ in.





B 995



B 996



B 997



B 998

CHAINS, CHAIN STAYS

Brass or Chromium-plated

- B 995. Lavatory chain and stay.
- B 996. Sink chain, 20 in. long, with wood screw.
- B 997. Bath chain, 20 in. long, with stud and nut.
- B 998. Bath chain, 20 in. long.
- B 998. Bath chain, 18 in. long.



No. B 825
TAP LEVER

Malleable Cast-iron

$\frac{3}{8}$, $\frac{1}{2}$, $\frac{3}{4}$, 1, $1\frac{1}{4}$, $1\frac{1}{2}$, 2 in.



No. B 850
STOP TAP KEY

One piece, wrought iron.

24, 30, 36 in. long



No. B 835
**ELBOW BACK
PLATE**

With plain tail.



No. B 836
**ELBOW BACK
PLATE**

With Union tail.



No. B 846
BACK NUT

- B 835. Back Plate. Polished Brass or Chromium-plated. Sizes : $\frac{1}{2}$ in., $\frac{3}{4}$ in.
- B 836. Back Plate. Polished Brass or Chromium-plated. Sizes : $\frac{1}{2}$ in., $\frac{3}{4}$ in.
- B 846. Back Nut. Brass. Sizes : $\frac{1}{2}$ in., $\frac{3}{4}$ in., 1 in., $1\frac{1}{4}$ in., $1\frac{1}{2}$ in., 2 in.

TAP TOP PARTS AND VALVES

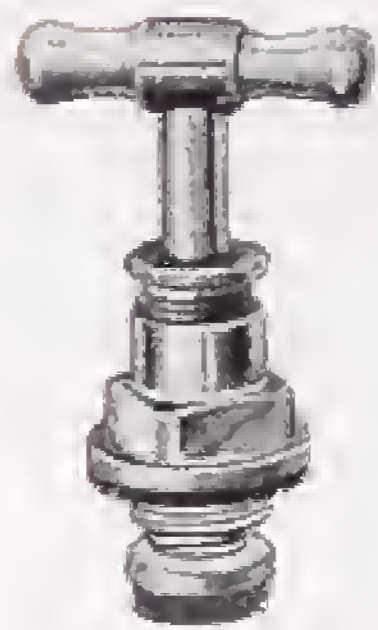

No. B 830



No. B 832



No. B 833



No. B 829



No. B 831

- B 830 Brass tee top, $\frac{3}{8}$, $\frac{1}{2}$, $\frac{3}{4}$, 1 in.
 B 831 Brass capstan head top, $\frac{1}{2}$, $\frac{3}{4}$ in.
 B 832 Valve with leather washer, $\frac{3}{8}$, $\frac{1}{2}$, $\frac{3}{4}$, 1 in.
 B 833 Valve with fibre washer, $\frac{3}{8}$, $\frac{1}{2}$, $\frac{3}{4}$, 1 in.
 B 829 "Holdtite" Valve with rubber washer, $\frac{1}{2}$, $\frac{3}{4}$ in.

TAP WASHERS, ETC.



No. B 837



No. B 838



No. B 839



No. B 840

- B 837 Washers for tap valves, leather or fibre, $\frac{3}{8}$ to 2 in.
 B 838 Body washers for taps, leather or fibre, $\frac{3}{8}$ to 2 in.
 B 839 Washers for caps and linings, leather, $\frac{3}{8}$ to 2 in.
 B 840 Ball valve washers, rubber, $\frac{3}{8}$, $\frac{1}{2}$, $\frac{3}{4}$, 1 in.
 B 956 Washers for tap valves, "Vacca" moulded type, $\frac{1}{2}$, $\frac{3}{4}$, 1 in.

W.C. CONES



No. B 815



No. B 6320



No. B 6321



No. B 817

- B 815 Stockinette and rubber cone, plain bulged shape, sizes $1\frac{1}{4} \times 2\frac{1}{2}$, $1\frac{1}{4} \times 2\frac{3}{4}$, $1\frac{1}{4} \times 3$, $1\frac{1}{2} \times 2\frac{1}{2}$, $1\frac{1}{2} \times 2\frac{3}{4}$, $1\frac{1}{2} \times 3$ in.
 B 817 Canvas covered indiarubber cone, corrugated shape, sizes $1\frac{1}{4} \times 2\frac{1}{2}$, $1\frac{1}{4} \times 2\frac{3}{4}$, $1\frac{1}{4} \times 2\frac{1}{2}$, $1\frac{1}{2} \times 2\frac{3}{4}$ in.
 B 6320 Polythene plain moulded cone, size $1\frac{1}{4} \times 2\frac{1}{2}$ in.
 B 6321 Heavy moulded rubber cone, plain single beaded type, sizes $1\frac{1}{4} \times 2\frac{1}{2}$, $1\frac{1}{4} \times 2\frac{3}{4}$, $1\frac{1}{2} \times 2\frac{1}{2}$, $1\frac{1}{2} \times 2\frac{3}{4}$ in.



No. B 814
**SUNFLOWER
 COPPER CONE**

Made in two sizes: one for ordinary W.C. nozzles and one for extra large nozzles.
 For $1\frac{1}{4}$ in. or $1\frac{1}{2}$ in. flush pipes
 Diam. of cone leaves, $4\frac{3}{4}$ in.
 or
 Diam. of cone leaves, 6 in.

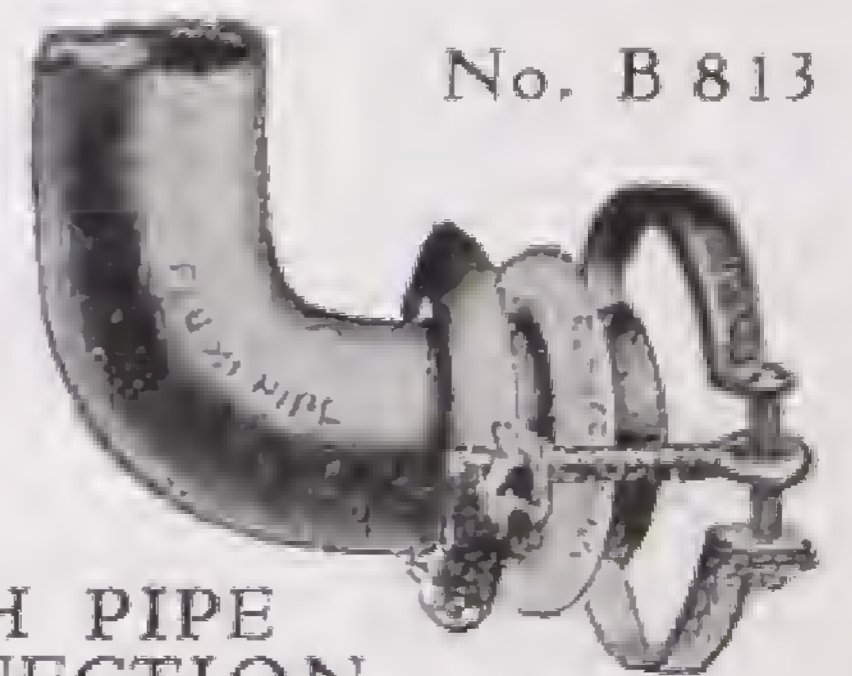

No. B 813

FLUSH PIPE CONNECTION
 Zinc Plated Steel. With Rubber Ring.
 Also supplied Chromium-plated.

BA X E N D A L E & C O . L T D .

PHILPLUG COLD CAULKING COMPOUND



Supplied in three forms, PC₃ being a loose fibre, PC₄ is in cored form, and PC₄(T) is in cored form for joints less than $\frac{1}{4}$ in. width.

This preparation consists of asbestos and cementitious materials specially produced for jointing all types of spigot and socket pipes, the caulking of grooves in cast-iron and concrete tunnel segments and for the fixing of balustrades and hand rails.

One ton of Philplug CCC will caulk as many joints as 6 tons of lead. No heat is required, and also the application of Philplug CCC is not affected by adverse weather conditions, which represents a valuable saving in time and money.

Normally stocked in 7 lb. tins ; Special Prices will be quoted for 1 cwt. and 1 ton lots.

BAKER'S SOLDERING FLUID

The ideal preparation for a quick clean job.

Sizes :

$2\frac{1}{2}$, 8, 12, 32 fluid ounces ;

and $\frac{1}{2}$, 1 gallon.



FLUXITE SOLDERING PASTE

For all metals (except aluminium) and for jointing lead without solder.

Sizes :



Sizes	Approx. weight
Junior tins ...	1 oz.
Small " ...	2 "
Medium " ...	6 "
Large " ...	16 "
7 lb. " ...	—

FLUXITE GUN for use with the above (extra).

Can also be used for hardening tools and case hardening—leaflet on request.

L I V E R P O O L · E D I N B U R G H · D U B L I N



No. 1
S Trap



No. 2
3/4 S Trap



No. 3
P Trap



No. 4
Bath or Running Trap

HYDRAULIC DRAWN LEAD TRAPS

With standard outlets and access caps.

Standard Sizes

Bore	Poundage of Lead
* 1 1/4 in.	} 4, 5, 6, 7, 8 lbs.
1 3/8 in.	
1 1/2 in.	
2 in.	

N.B. — * The 1 1/4 in. size traps are also supplied in 4 1/2 lbs. lead.
Special traps with long outlets or inlets can be supplied at an extra charge.



No. 1
S Trap



No. 2
3/4 S Trap



No. 3
P Trap

HYDRAULIC DRAWN LEAD ANTI-SIPHON TRAPS

Fitted with access cap, and with 3-in. diameter anti-siphon air chamber burned in.

These traps are used in conjunction with sanitary installations in modern flats and hotels. There are no by-pass pipes to choke up. The air chambers are of the same substance as the body of the trap. Extra access caps can be supplied when required.

All the traps have a deep water seal—about 4 in.
Long inlets, outlets, or both can be supplied (*Extra*).

Standard Sizes

Bore	Poundage of Lead
1 1/4 in.	} 5, 6, 7, 8, 9, 10 lbs.
1 1/2 in.	
2 in.	

HYDRAULIC DRAWN
LEAD BENDS

Standard Angles 95°



Standard Sizes

8 x 12	8 x 18	8 x 21	8 x 24	9 x 18	9 x 36	9 x 40 in.
12 x 12	12 x 18	12 x 24	12 x 30	15 x 18	18 x 18	24 x 18 in.

<i>Bore</i>	<i>Poundage of Lead</i>
2½ in.	} 5, 6, 7, 8, 10 lbs.
3 in.	
3½ in.	
4 in.	

HYDRAULIC DRAWN
LEAD OFFSETS

Standard measurements of
Down pipes, 6 in.



Standard Sizes

3 in., 6 in., 9 in., 12 in., 18 in., 24 in. centres.

<i>Bore</i>	<i>Poundage of Lead</i>
1½ in.	} 4, 5, 6, 7, 8 lbs.
2 in.	
2½ in.	} 5, 6, 7, 8, 10 lbs.
3 in.	
3½ in.	
4 in.	

Prices for other diameters, weights, and measurements given on application.



† Unions position A.

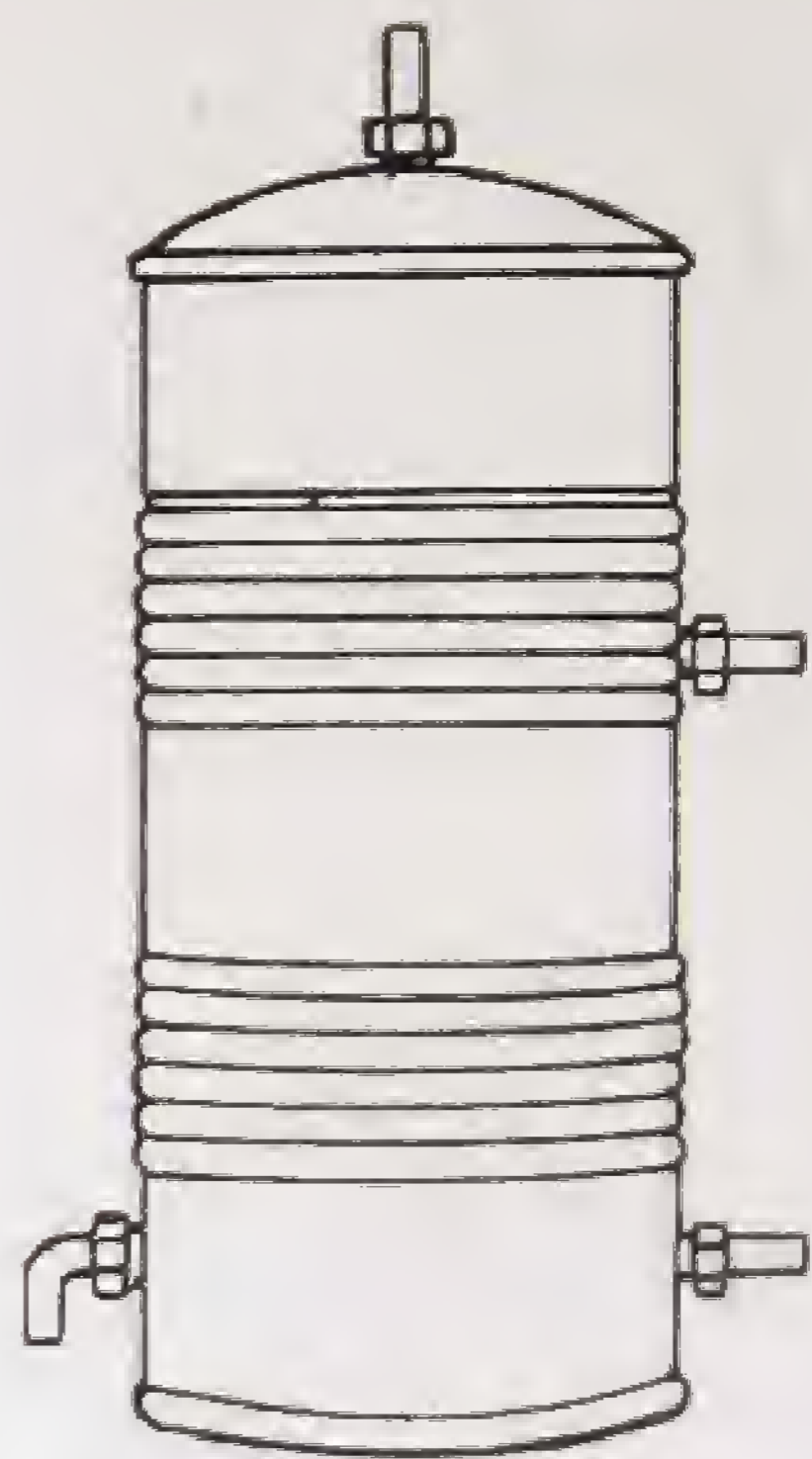

† Unions position F.

No. B 3071. COPPER CYLINDER

Light part corrugated pattern.

With Silver-Alloy Brazed Seams and four $\frac{3}{4}$ in. Unions for Lead. Test Pressure $12\frac{1}{2}$ lbs. Maximum Working Head 20 ft.

		Sizes.			
Height	Diameter	Height	Diameter	Height	Diameter
24 in.	} 12, 13, 14, 15 in.	36 in.	} 12, 13, 14, 15 in.	39 in.	} 12, 13, 14, 15 in.
27 in.		42 in.			
30 in.		48 in.			
33 in.					

- EXTRAS {
- 1-in. unions in place of $\frac{3}{4}$ in.
 - $1\frac{1}{4}$ -in. " " " "
 - Additional unions, $\frac{3}{4}$ in., 1 in., or $1\frac{1}{4}$ in.
 - " bosses, $\frac{1}{2}$ in., $\frac{3}{4}$ in., or 1 in.
 - Loose boiler unions, $\frac{3}{4}$ in. or 1 in.
 - Single bolt centre pin handhole.
 - Fixing heater boss.
 - Screwed female unions.

DEDUCTIONS : $\frac{3}{4}$ -in. or 1-in. bosses in place of $\frac{3}{4}$ -in. unions.

Special sizes made to order.

† Cylinders can be supplied with the flow union or boss two-thirds way up the cylinder as line drawing position F which we recommend because hot water can be drawn much quicker after circulation has commenced.

**Actual Capacities of Copper Cylinders
(in gallons)**

Ht.	Dia.						
	12 in.	13 in.	14 in.	15 in.	16 in.	17 in.	18 in.
24 in.	8	9 $\frac{1}{2}$	10 $\frac{3}{4}$	12 $\frac{1}{4}$	14	15 $\frac{1}{2}$	17 $\frac{3}{4}$
27 in.	9	10 $\frac{1}{2}$	12 $\frac{1}{4}$	13 $\frac{1}{4}$	16	18	20
30 in.	10	11 $\frac{1}{4}$	13 $\frac{3}{4}$	15 $\frac{1}{2}$	18	20 $\frac{1}{4}$	22 $\frac{1}{4}$
33 in.	11	13	15 $\frac{1}{2}$	17 $\frac{1}{4}$	20 $\frac{1}{4}$	22 $\frac{1}{2}$	25 $\frac{1}{2}$
36 in.	12	14 $\frac{1}{2}$	17 $\frac{1}{4}$	19 $\frac{1}{4}$	22 $\frac{1}{4}$	25	28
39 in.	13	15 $\frac{3}{4}$	18 $\frac{1}{2}$	21 $\frac{1}{4}$	24 $\frac{1}{4}$	27 $\frac{1}{4}$	30 $\frac{1}{4}$
42 in.	14	17	20	23 $\frac{1}{4}$	26 $\frac{1}{4}$	29 $\frac{1}{4}$	33 $\frac{1}{4}$
48 in.	16	19 $\frac{1}{2}$	23	26 $\frac{1}{4}$	30 $\frac{1}{4}$	34 $\frac{1}{4}$	38 $\frac{1}{2}$

BAXENDALE & CO. LTD.



† Unions position A



† Unions position F

No. B 3070. COPPER CYLINDER

Plain pattern with brazed vertical seam and four $\frac{3}{8}$ -in. Unions for lead.

Guaranteed Gauges

Standard Heights : 24, 27, 30, 33, 36, 39, 42, 48 in.

Standard Diameters : 12, 13, 14, 15, 16, 17, 18 in.

Gauges

Working Details

Top and Body	Bottom	Diameter	Test Pressure	Max. Working Head
22 S.W.G.	18 S.W.G.	All Diameters	20 lbs.	30 feet
20 S.W.G.	17 S.W.G.	}	40 lbs.	60 feet
18 S.W.G.	16 S.W.G.		30 lbs.	50 feet
		}	50 lbs.	60 feet
			35 lbs.	50 feet

B.S.S. 699 — 1951

B.S. Size No.	Dimensions		Actual Capacity	Grade 1	Grade 2	Grade 3
	Ext. Ht.	Ext. Dia.		Max. permissible working head 100 ft.	Max. permissible working head 60 ft.	Max. permissible working head 30 ft.
				W.G.	W.G.	W.G.
1	36	14	17 $\frac{1}{2}$	17/15	20/17	22/18
2	36	16	22 $\frac{1}{2}$	16/14	19/16	22/18
3	27	18	20	15/13	18/15	22/18
4	30	18	22 $\frac{1}{2}$	15/13	18/15	22/18
5	33	18	25 $\frac{1}{2}$	15/13	18/15	22/18
6	36	18	28	15/13	18/15	22/18
7	42	18	33 $\frac{1}{2}$	15/13	18/15	22/18

No. B 3030. LARGE COPPER CYLINDERS

Gallons ...	50	60	75	85	95	100	150	200	300
Height in ins. ...	48	48	48	54	60	63	60	72	72
Diameter in ins. ...	20	21	24	24	24	24	30	32	39

Please state Pressure Test required when ordering.

† See note on previous page re unions.

BAXENDALE & CO. LTD.

SIZES B 3075



No. B 3075
COPPER CALORIFIER
 Vertical coil pattern.
 For Domestic Hot Water Supply.

Size		Capacity	Heating Surface
Height	Dia.	Galls.	Sq. ft.
35"	15"	20	4
30"	18"	24	5½
36"	18"	30	6
42"	18"	35	7
48"	18"	40	8
50"	20"	50	10
58"	20"	60	12
54"	24"	80	16
69"	24"	100	20
66"	30"	150	30
77"	32"	200	40
75"	36"	250	50
78"	39"	300	60

Recommended where there is an appreciable difference in pressure between the two circuits.

SIZES B 3080

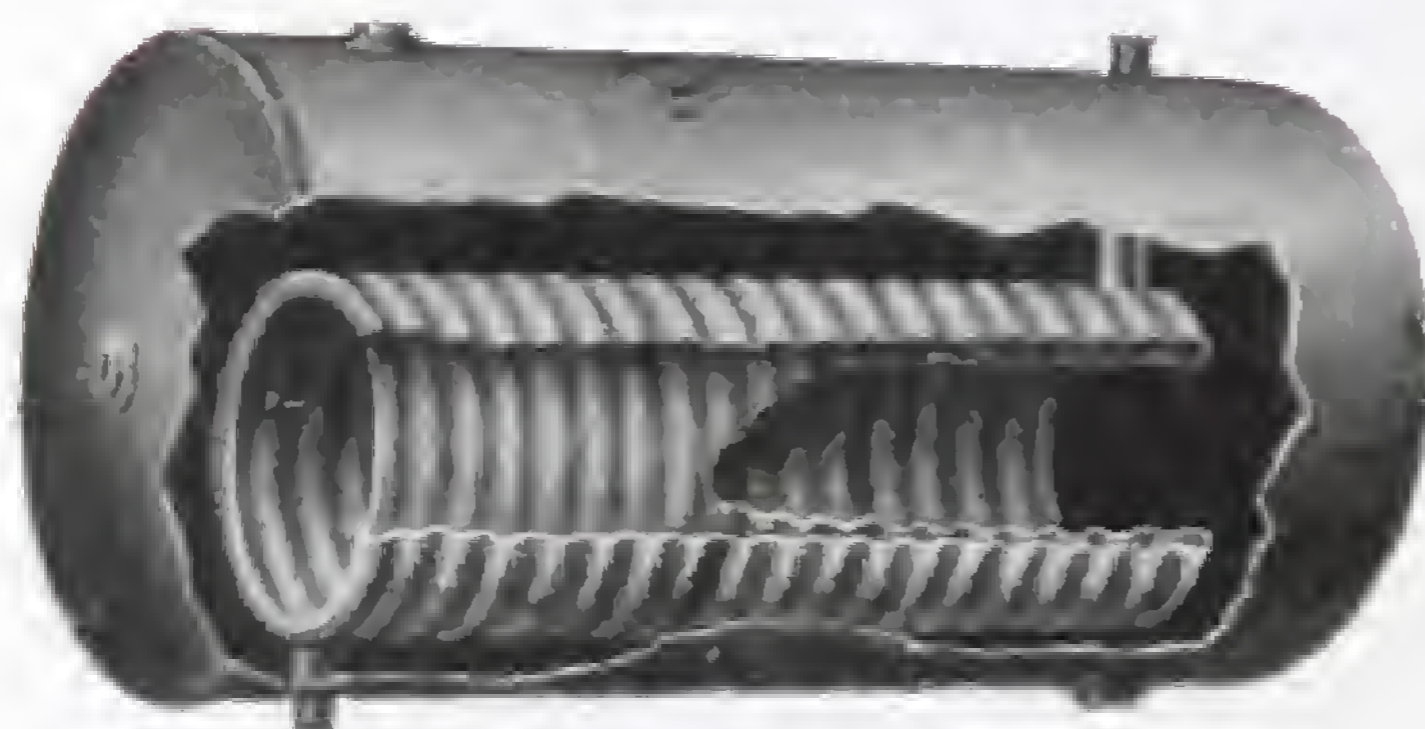

No. B 3080
COPPER INDIRECT CYLINDER
 Annular Type
 For Hot Water circulation.

For vertical or horizontal position.
 2 male bosses on primary circulation and 3 female bosses on secondary circulation.
 The Annular Type is suitable for use where there is only small difference of pressure between the two circuits.

Size		Capacity	Heating Surface
Height	Dia.	Galls.	Sq. ft.
35"	15"	20	7
30"	18"	24	8
36"	18"	30	9½
42"	18"	35	12
48"	18"	40	14
50"	20"	50	17
58"	20"	60	20
54"	24"	80	27
69"	24"	100	34
66"	30"	150	50
77"	32"	200	66
75"	36"	250	83½
78"	39"	300	100

We supply Calorifiers for every purpose and of all capacities.
 Quotations will be sent on application stating requirements.

MILLER STREET · MANCHESTER



No. B 3102

COMBINATION HOT WATER TANK

With brazed seams, comprising cold supply tank and copper hot water cylinder combined, the two being separated by special insulation.

Standard size is 36 in. x 18 in. nominal capacity 20 gallons hot and 10 gallons cold water. Special sizes and immersion heater bosses and circulating coils can be supplied as extras.

No. B 3103

INSULATING JACKET

Made to suit any size of cylinder and easily fitted in the form of segments secured by hooks to a flexible wire band. The jacket is held in position on the cylinder with black steel bands and clips. The segments are filled with special mineral wool and the outsides are finished in glazed water-proof material.



No. B 3104

THE PRIMATIC UNIVERSAL CYLINDER

A copper indirect cylinder of special design avoiding the necessity for duplicate supply system, ballvalve and piping. It is entirely self-contained, eliminates scale deposits in the primary system, and providing frequent boiling conditions are avoided, the water at the service taps will be free from discoloration.

Sizes	36 x 15	39 x 15	36 x 16	39 x 16	36 x 18	42 x 18	48 x 18 in.
Nominal Capacity ...	20	24	25	27	30	35	40 galls.



No. B 3488. STEAM KETTLE

Substantially made of strong hard-rolled copper and heated by copper steam coil fitted with steam inlet valve, gun-metal draw-off tap with lever handle. Loose lid top. All inside surfaces tinned.

The steam inlet and exhaust can be fixed in any position to suit requirements.

Sizes : 4, 6, 8, 10, 15, 20, 25, 30 and 40 Galls.

No. B 3489. STEAM-HEATED WATER BOILER

SELF-FEED TYPE

Within a few moments of turning on the steam a continuous and unlimited supply of boiling water is available and may be drawn off at the rate of from one half-gallon to four gallons per minute according to size of boiler.

It is only necessary to turn on the steam, draw off the boiling water as much or little as required, then turn off the steam when finished. Any young girl can operate it with perfect safety.



It is absolutely free from any complications or gadgets likely to get out of order or to require skilled attention, having been designed with this special object in view ; it is, in fact, as simple as an ordinary steam kettle, with the following advantages :—

It is self-feeding. Boiling water supply is continuous and unlimited. It is instantaneous in action. Is absolutely safe. Designed and built for rough, hard usage.

It is highly efficient and economical in use—it is not necessary to boil a large bulk of water out of all proportion to the amount actually required for use, as is often the case with the ordinary steam kettle.

Sizes	0	1	2	3	4	5	6
Boiling Capacity } Galls. per min. ...	½	1	1½	2	2½	3	4
No. of Taps ...	1	1	2	3	4	4	5

BAXENDALE & CO. LTD.

SANTON DOMESTIC IMMERSION HEATERS "R" TYPE

Withdrawable Elements

2 1/4 in. B.S.P.T. Head, A.C. or D.C. (Thermo-Immersioners) with Pockets for Thermostats



THE SANTON CIRC-STAT

A thermostatically controlled Electric Heater: automatically switches current on and off when the temperature of the water falls below or rises above a predetermined figure. Made in various lengths and loadings to suit differing requirements as to space allowable and time limits.

	Loading	Length of Tube
No. EH 883	2 K-W.	18 in.
No. EH 884	3 "	18 "
No. EH 885	2 "	21 "
No. EH 886	3 "	21 "
No. EH 887	2 "	27 "
No. EH 888	3 "	27 "
No. EH 889	4 "	27 "
No. EH 890	2 "	30 "
No. EH 891	3 "	30 "

Voltages 200/230 230/250 A.C.

The length of the heater is determined by the depth to which it is required to heat the water.

Sweat-in Flanges

- No. EH 900 Built-up Type Copper Cylinder
- No. HH 901 Flat Type " "

SANTON "OTTER" RANGE OF IMMERSION HEATERS

2 1/4 in. B.S.P.T. without Thermostats

No.	Length	Load K.W.	Voltage	Orientation
No. EH 902	11 in.	2 1/2	200/220 and 230/250 A.C. and D.C.	Horizontal
No. EH 903	11 in.	3		"
No. EH 904	13 in.	3		"
No. EH 905	18 in.	3		Horizontal or Vertical
No. EH 906	23 in.	3		Vertical
No. EH 907	27 in.	3		"
No. EH 908	30 in.	3		"
No. EH 909	36 in.	3	230/250 only	"
No. EH 910	16 in.	4		"
No. EH 911	36 in.	4		"

The above Heaters are without Thermostats. If required for Santon Otter Thermostat (fixed settings) 140°, 160°, 180° F. can be supplied for D.C.

BAXENDALE & CO. LTD.



No. B 3091

No. B 3091 COPPER BUNGALOW BOILER

With $\frac{3}{4}$ -in. unions for lead or screwed female bosses.

Frontage	Sizes			Approximate weights (with unions)	
	Top	Bottom	Height	$\frac{3}{16}$ -in. plate	$\frac{1}{4}$ -in. plate
10	6	6	6 in.	20	26 lbs.
12	6	6	6 "	22	29 "
14	6	6	6 "	25	32 "

N.B.—Boilers with bosses weigh about 2 lbs. less than above.



No. B3092

No. B 3092 COPPER BACK-TO-BACK BOILER

With $\frac{3}{4}$ -in. unions for lead or screwed female bosses
Also supplied with long extension pipes and unions

	Frontage	Top	Bottom	Height
Size	... 12 in.	4 in.	4 in.	6 in.

Made in $\frac{1}{8}$ -in. and $\frac{3}{16}$ -in. plate.
*When ordering please state hand required.
Illustration shows a right-hand boiler.*

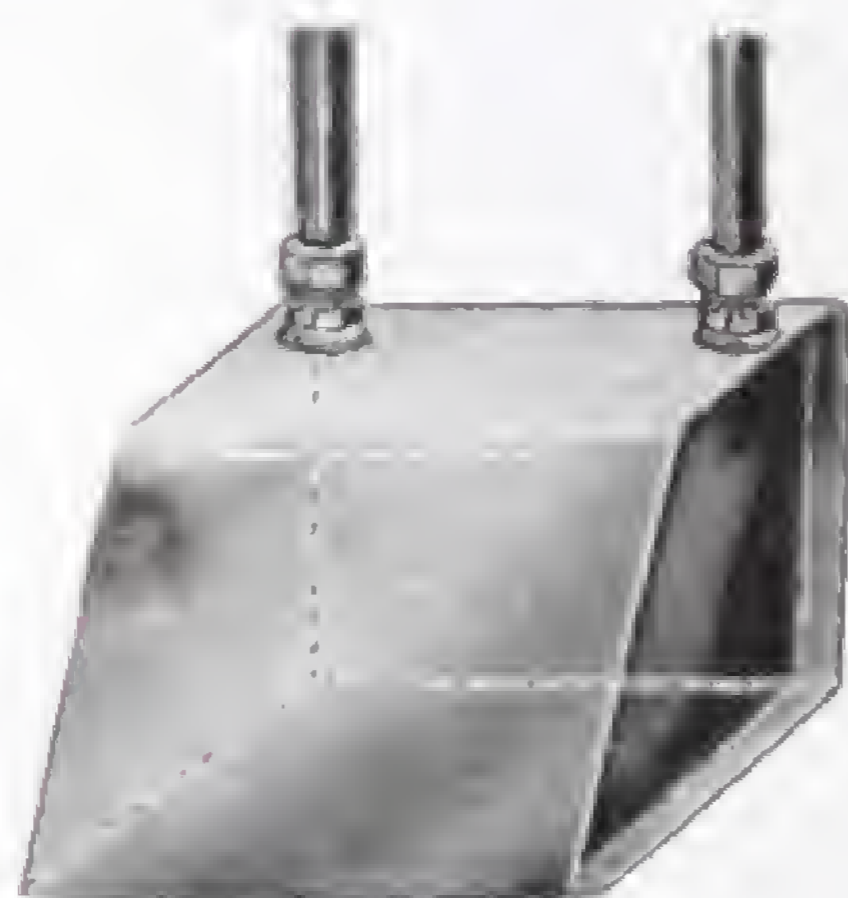

No. B 3083 COPPER PLAIN BOILER

With $\frac{3}{4}$ -in. or 1-in. unions for lead or screwed female bosses.

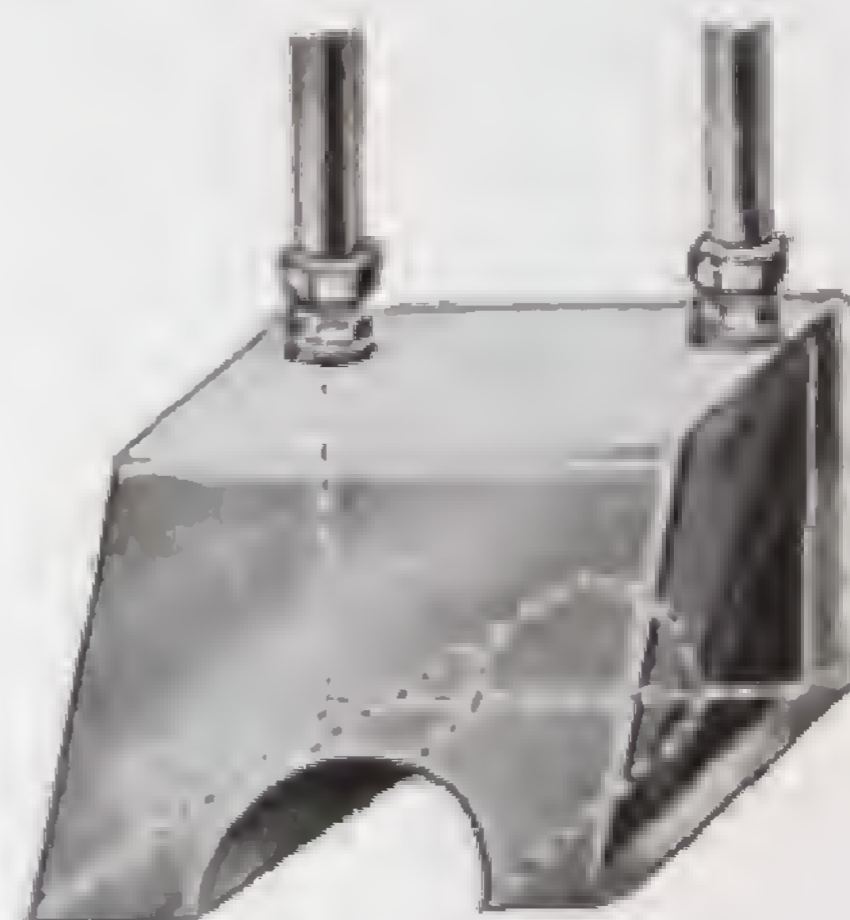

No. B 3095 COPPER FLUE BOILER

With $\frac{3}{4}$ -in. or 1-in. unions for lead or screwed female bosses.

APPROXIMATE WEIGHTS (with $\frac{3}{4}$ -in. Unions) :

Frontage	Top	Bottom	Height	No. B 3083		No. B 3095	
				$\frac{3}{16}$ -in. plate	$\frac{1}{4}$ -in. plate	$\frac{3}{16}$ -in. plate	$\frac{1}{4}$ -in. plate
10	6	8	8 in.	28	34	30	36 lbs.
12	6	8	8 "	32	38	34	40 "
10	6	8	9 "	30	36	32	38 "
12	6	8	9 "	34	40	36	42 "
10	7	9	9 "	35	42	38	45 "
12	7	9	9 "	38	45	41	48 "
10	12	12	6 "	36	42	40	46 "
12	12	12	6 "	40	48	44	52 "

*N.B.—Boilers with bosses weigh about 2 lbs. less than above.
If fitted with Handhole, Boilers weigh about 5 lbs. more than above.
Copper Boilers can be supplied to suit all ranges.*

MILLER STREET · MANCHESTER

WROUGHT WELDED BOILERS

Wrought Welded Boilers are calculated on the Girth Measurements and Width.

To ascertain the Girth Measurement add together :

Top	Bottom	Height
B	+ C	+ twice D
A = Width		

When ordering give sizes in the following order :—

$$A \times B \times C \times D$$

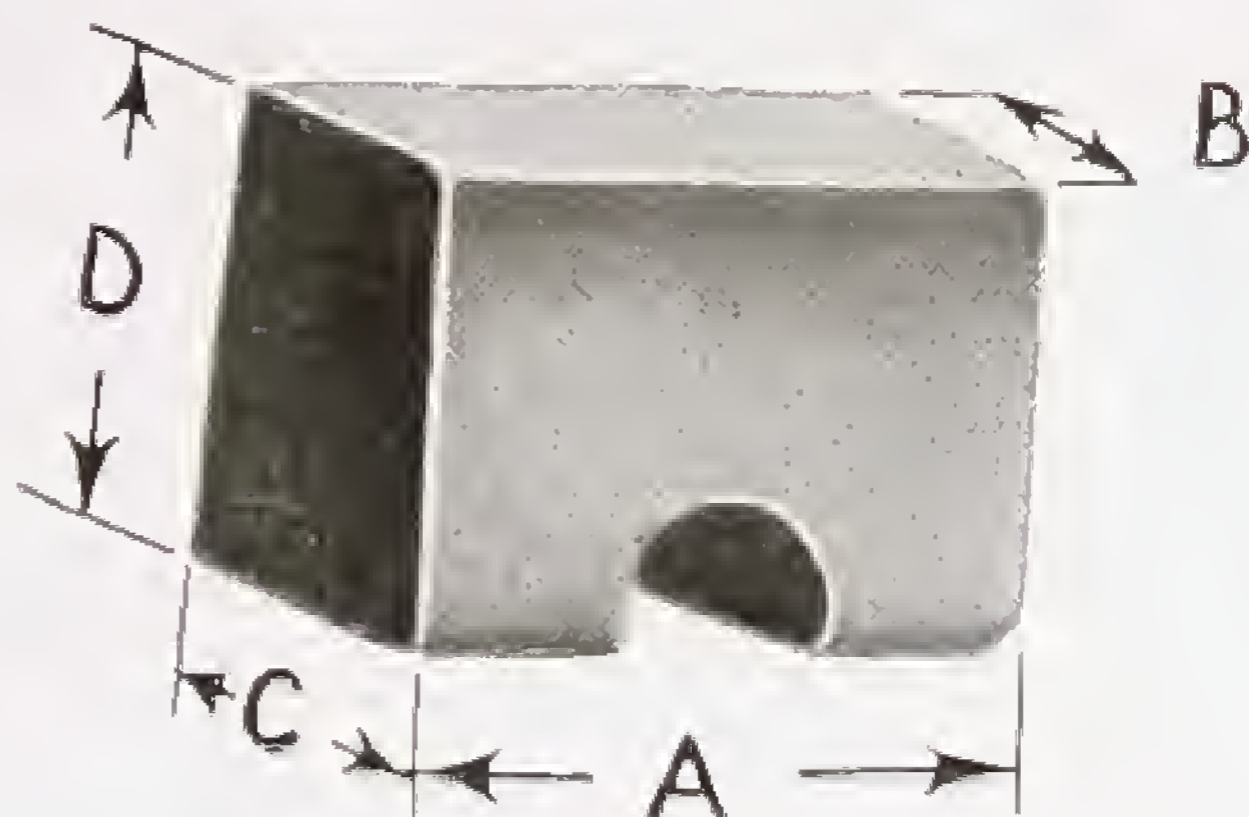

For Code of Tappings see page 171.

WELDED RANGE BOILERS

ARCH BOILERS, $\frac{5}{16}$ in. PLATE

Width of Boiler in inches ... 10, 11, 12, 13, 14, 15, 16, 17, 18

Girth inches up to ... 25, 27, 29, 31, 33, 35, 37, 39, 41, 43, 45, 47, 49

All orders are sent carriage paid, but a NET EXTRA is charged for less than 4. Boilers include Cover and Joint Ring and are with or without two $\frac{3}{4}$ in. or 1 in. tappings.

For Code of Tappings see page 171.

WELDED RANGE BOILERS

ARCH BOILERS $\frac{3}{8}$ in. PLATE

Width of Boiler in inches ... 10, 11, 12, 13, 14, 15, 16, 17, 18

Girth inches up to ... 25, 27, 29, 31, 33, 35, 37, 39, 41, 43, 45, 47, 49

All orders are sent carriage paid, but a NET EXTRA is charged for less than 4. Boilers include Cover and Joint Ring and are with or without two $\frac{3}{4}$ in. or 1 in. tappings.

WROUGHT WELDED BOILERS

Wrought Welded Boilers are calculated on the Girth Measurements and Width, see Diagrams.



To ascertain the Girth Measurement add together.

$$\begin{array}{r} \text{Top} \quad \text{Bottom} \quad \text{Height} \\ B \quad + \quad C \quad + \quad \text{twice } D \\ \hline A = \text{Width} \end{array}$$

When ordering give Sizes in the following order :—

$$A \times B \times C \times D.$$

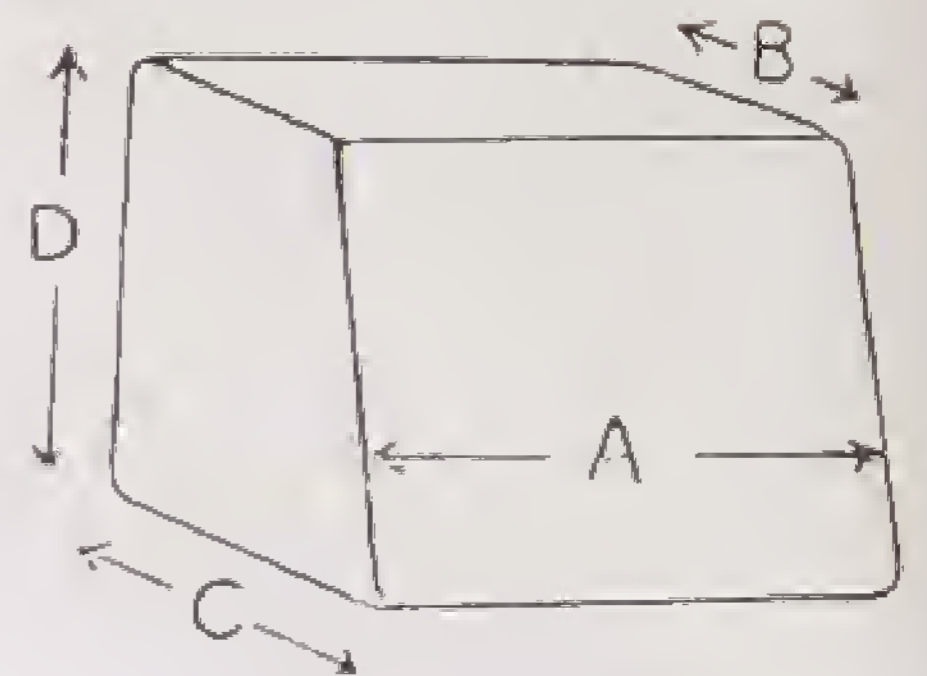

WELDED RANGE BOILERS

PLAIN BOILERS $\frac{3}{8}$ in. PLATE

Width of Boiler in inches ... 10, 11, 12, 13, 14, 15, 16, 17, 18

Girth inches up to ... 25, 27, 29, 31, 33, 35, 37, 39, 41, 43 45, 47, 49

All orders are sent carriage paid, but a NET EXTRA is charged for less than 4. Boilers include Cover and Joint Ring and are with or without two $\frac{3}{8}$ in. or 1 in. tappings.

WELDED RANGE BOILERS

PLAIN BOILERS, $\frac{5}{16}$ in. PLATE

Width of Boiler in inches ... 10, 11, 12, 13, 14, 15, 16, 17, 18

Girth inches up to ... 25, 27, 29, 31, 33, 35, 37, 39, 41, 43, 45, 47, 49

All orders are sent carriage paid, but a NET EXTRA is charged for less than 4. Boilers include Cover and Joint Ring and with or without two $\frac{3}{8}$ in. or 1 in. tappings.

TAPPINGS (For Code of Tapped Holes see pages 171)

BOWER BARFFING OR GALVANIZING EXTRA

WROUGHT WELDED NEWCASTLE AND OTHER LARGE BACK BOILERS



With Cover. $\frac{5}{16}$ in. Plate.

Including 4 in. Stamped Cover.

With or without 2 holes for Pipes, any size, tapped or untapped.

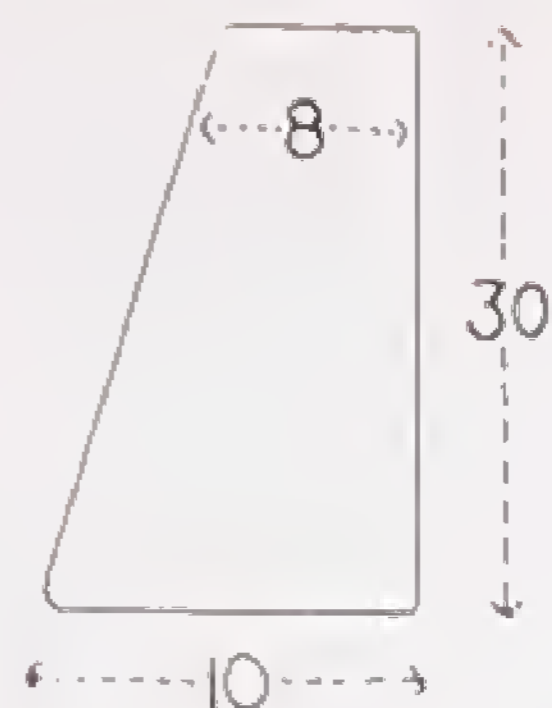

To ascertain the girth measurement add together top and bottom and twice the height, i.e.—
 $8 + 10 = 18$
 Twice 30 = 60

 78

WELDED RANGE BOILERS

NEWCASTLE AND OTHER LARGE BOILERS $\frac{5}{16}$ in.

Including 4 in. Double-Nut Cover and Ring, and 2 Tappings.

Width of Boiler in inches ... 10, 11, 12, 13, 14, 15, 16, 17, 18

Girth inches up to ... 52, 54, 57, 60, 63, 66, 69, 72, 75, 78, 81, 84, 87, 90, 93, 96, 99, 102

Single Boilers carriage paid (goods).

WELDED RANGE BOILERS

NEWCASTLE AND OTHER LARGE BOILERS $\frac{3}{8}$ in.

Including 4 in. Double-Nut Cover and Ring, and 2 Tappings.

Width of Boiler in inches ... 10, 11, 12, 13, 14, 15, 16, 17, 18

Girth inches up to ... 52, 54, 57, 60, 63, 66, 69, 72, 75, 78, 81, 84, 87, 90, 93, 96, 99, 102

Single Boilers carriage paid (goods).

Newcastle Boilers Incur Extras—if fitted with :—

5 in. diameter D.N. Cover and Ring.	Raised Flow.
6 in. Set Screw Cover.	Arch Flues, per inch back to front.
Rubber Joint Ring for ditto.	Intersecting Flues, per inch total length.
Asbestos Ring for ditto.	Additional Tappings (see page 171).

For Boilers over 18 in. wide, the difference between 17 in. and 18 in. is charged for each additional inch.

All fractions of 1 in. in girth or width are taken at next larger size.

Bower Barffing or Galvanizing can be arranged.

See page 171 for method of ordering, and tapping chart, Single Boilers carriage paid (goods).

WELDED RANGE BOILERS

In all Boilers we include Double Nut Covers up to 4 in. dia., or Oval Covers up to $5\frac{1}{2}$ in. \times $2\frac{3}{4}$ in., but no allowance can be made if holes for Covers are cut but Covers not supplied. A Joint Ring is included and two tappings up to 1 in. if required but no allowance can be made if tappings are not required.

Fractions of 1 in. in width or girth are taken at next largest size. Under 10 in. wide are at 10 in. price ; under 25 in. girth at 25 in. price ; over 18 in. wide, for each additional inch, add difference between 17 in. and 18 in. price. Over 49 in. girth, i.e., Newcastle type Intersecting Flue and other Special Boilers, see page 170.

WARNING.—Cover Joints should be remade before fixing as they may have been disturbed in transit.



WROUGHT WELDED BOOT BOILERS

$\frac{5}{16}$ in. Plate. Round or Square Toe.

Supplied to any measurement.

WELDED BOILERS

Code of Instructions for Orders

Code for Ordering Boilers by Letter, Telephone or Telegraph:—

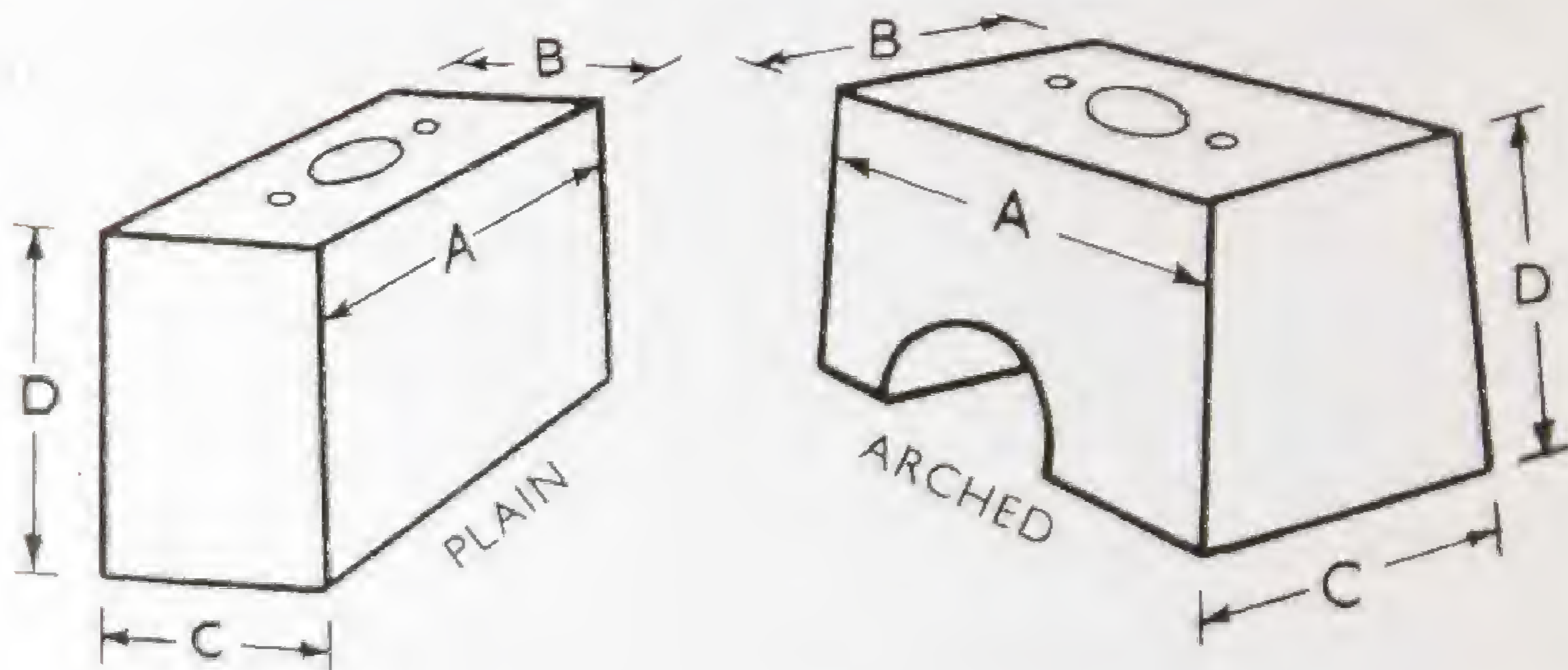

Give the sizes in the order shown above — A for width, B for top, C for bottom, D for height — state if arch or plain and give thickness of plate, and with or without cover.

See page 171 for Code for tapped holes.

Example :

One plain Boiler 12. $\frac{5}{16}$. 7. $\frac{5}{16}$ Cover. 2-1 inch E.

BOWER BARFING OR GALVANIZING: EXTRA

WELDED RANGE BOILERS

CODE DIAGRAMS

For Indicating Positions of Tapping Holes

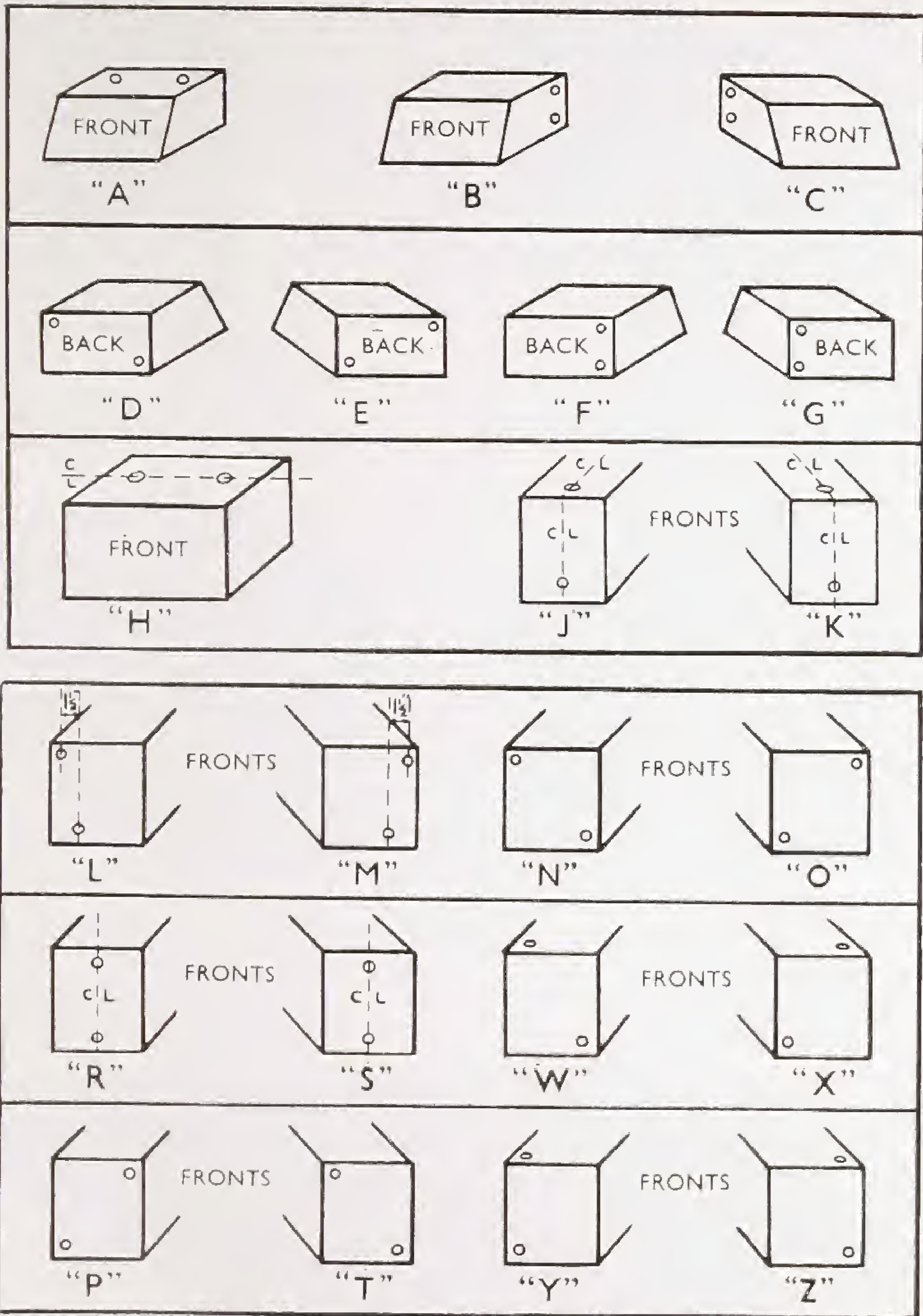

When ordering Boilers to be Drilled and Tapped, please use above Code and state size of hole and the Indicating Letter to avoid errors.

BAXENDALE & CO. LTD.

GALVANIZED TANKS, CISTERNS AND CYLINDERS



We can supply all sizes of Storage Tanks with Square, Rectangular or Cylindrical ends, and also with 24, 30, 36, 42, 48, 54, 60, 66, 72, 78, 84, 90, 96, 102, 108, 114, 120, 126, 132, 138, 144, 150, 156, 162, 168, 174, 180, 186, 192, 198, 204, 210, 216, 222, 228, 234, 240, 246, 252, 258, 264, 270, 276, 282, 288, 294, 300, 306, 312, 318, 324, 330, 336, 342, 348, 354, 360, 366, 372, 378, 384, 390, 396, 402, 408, 414, 420, 426, 432, 438, 444, 450, 456, 462, 468, 474, 480, 486, 492, 498, 504, 510, 516, 522, 528, 534, 540, 546, 552, 558, 564, 570, 576, 582, 588, 594, 600, 606, 612, 618, 624, 630, 636, 642, 648, 654, 660, 666, 672, 678, 684, 690, 696, 702, 708, 714, 720, 726, 732, 738, 744, 750, 756, 762, 768, 774, 780, 786, 792, 798, 804, 810, 816, 822, 828, 834, 840, 846, 852, 858, 864, 870, 876, 882, 888, 894, 900, 906, 912, 918, 924, 930, 936, 942, 948, 954, 960, 966, 972, 978, 984, 990, 996, 1002, 1008, 1014, 1020, 1026, 1032, 1038, 1044, 1050, 1056, 1062, 1068, 1074, 1080, 1086, 1092, 1098, 1104, 1110, 1116, 1122, 1128, 1134, 1140, 1146, 1152, 1158, 1164, 1170, 1176, 1182, 1188, 1194, 1200, 1206, 1212, 1218, 1224, 1230, 1236, 1242, 1248, 1254, 1260, 1266, 1272, 1278, 1284, 1290, 1296, 1302, 1308, 1314, 1320, 1326, 1332, 1338, 1344, 1350, 1356, 1362, 1368, 1374, 1380, 1386, 1392, 1398, 1404, 1410, 1416, 1422, 1428, 1434, 1440, 1446, 1452, 1458, 1464, 1470, 1476, 1482, 1488, 1494, 1500, 1506, 1512, 1518, 1524, 1530, 1536, 1542, 1548, 1554, 1560, 1566, 1572, 1578, 1584, 1590, 1596, 1602, 1608, 1614, 1620, 1626, 1632, 1638, 1644, 1650, 1656, 1662, 1668, 1674, 1680, 1686, 1692, 1698, 1704, 1710, 1716, 1722, 1728, 1734, 1740, 1746, 1752, 1758, 1764, 1770, 1776, 1782, 1788, 1794, 1800, 1806, 1812, 1818, 1824, 1830, 1836, 1842, 1848, 1854, 1860, 1866, 1872, 1878, 1884, 1890, 1896, 1902, 1908, 1914, 1920, 1926, 1932, 1938, 1944, 1950, 1956, 1962, 1968, 1974, 1980, 1986, 1992, 1998, 2004, 2010, 2016, 2022, 2028, 2034, 2040, 2046, 2052, 2058, 2064, 2070, 2076, 2082, 2088, 2094, 2100, 2106, 2112, 2118, 2124, 2130, 2136, 2142, 2148, 2154, 2160, 2166, 2172, 2178, 2184, 2190, 2196, 2202, 2208, 2214, 2220, 2226, 2232, 2238, 2244, 2250, 2256, 2262, 2268, 2274, 2280, 2286, 2292, 2298, 2304, 2310, 2316, 2322, 2328, 2334, 2340, 2346, 2352, 2358, 2364, 2370, 2376, 2382, 2388, 2394, 2400, 2406, 2412, 2418, 2424, 2430, 2436, 2442, 2448, 2454, 2460, 2466, 2472, 2478, 2484, 2490, 2496, 2502, 2508, 2514, 2520, 2526, 2532, 2538, 2544, 2550, 2556, 2562, 2568, 2574, 2580, 2586, 2592, 2598, 2604, 2610, 2616, 2622, 2628, 2634, 2640, 2646, 2652, 2658, 2664, 2670, 2676, 2682, 2688, 2694, 2700, 2706, 2712, 2718, 2724, 2730, 2736, 2742, 2748, 2754, 2760, 2766, 2772, 2778, 2784, 2790, 2796, 2802, 2808, 2814, 2820, 2826, 2832, 2838, 2844, 2850, 2856, 2862, 2868, 2874, 2880, 2886, 2892, 2898, 2904, 2910, 2916, 2922, 2928, 2934, 2940, 2946, 2952, 2958, 2964, 2970, 2976, 2982, 2988, 2994, 3000, 3006, 3012, 3018, 3024, 3030, 3036, 3042, 3048, 3054, 3060, 3066, 3072, 3078, 3084, 3090, 3096, 3102, 3108, 3114, 3120, 3126, 3132, 3138, 3144, 3150, 3156, 3162, 3168, 3174, 3180, 3186, 3192, 3198, 3204, 3210, 3216, 3222, 3228, 3234, 3240, 3246, 3252, 3258, 3264, 3270, 3276, 3282, 3288, 3294, 3300, 3306, 3312, 3318, 3324, 3330, 3336, 3342, 3348, 3354, 3360, 3366, 3372, 3378, 3384, 3390, 3396, 3402, 3408, 3414, 3420, 3426, 3432, 3438, 3444, 3450, 3456, 3462, 3468, 3474, 3480, 3486, 3492, 3498, 3504, 3510, 3516, 3522, 3528, 3534, 3540, 3546, 3552, 3558, 3564, 3570, 3576, 3582, 3588, 3594, 3600, 3606, 3612, 3618, 3624, 3630, 3636, 3642, 3648, 3654, 3660, 3666, 3672, 3678, 3684, 3690, 3696, 3702, 3708, 3714, 3720, 3726, 3732, 3738, 3744, 3750, 3756, 3762, 3768, 3774, 3780, 3786, 3792, 3798, 3804, 3810, 3816, 3822, 3828, 3834, 3840, 3846, 3852, 3858, 3864, 3870, 3876, 3882, 3888, 3894, 3900, 3906, 3912, 3918, 3924, 3930, 3936, 3942, 3948, 3954, 3960, 3966, 3972, 3978, 3984, 3990, 3996, 4002, 4008, 4014, 4020, 4026, 4032, 4038, 4044, 4050, 4056, 4062, 4068, 4074, 4080, 4086, 4092, 4098, 4104, 4110, 4116, 4122, 4128, 4134, 4140, 4146, 4152, 4158, 4164, 4170, 4176, 4182, 4188, 4194, 4200, 4206, 4212, 4218, 4224, 4230, 4236, 4242, 4248, 4254, 4260, 4266, 4272, 4278, 4284, 4290, 4296, 4302, 4308, 4314, 4320, 4326, 4332, 4338, 4344, 4350, 4356, 4362, 4368, 4374, 4380, 4386, 4392, 4398, 4404, 4410, 4416, 4422, 4428, 4434, 4440, 4446, 4452, 4458, 4464, 4470, 4476, 4482, 4488, 4494, 4500, 4506, 4512, 4518, 4524, 4530, 4536, 4542, 4548, 4554, 4560, 4566, 4572, 4578, 4584, 4590, 4596, 4602, 4608, 4614, 4620, 4626, 4632, 4638, 4644, 4650, 4656, 4662, 4668, 4674, 4680, 4686, 4692, 4698, 4704, 4710, 4716, 4722, 4728, 4734, 4740, 4746, 4752, 4758, 4764, 4770, 4776, 4782, 4788, 4794, 4800, 4806, 4812, 4818, 4824, 4830, 4836, 4842, 4848, 4854, 4860, 4866, 4872, 4878, 4884, 4890, 4896, 4902, 4908, 4914, 4920, 4926, 4932, 4938, 4944, 4950, 4956, 4962, 4968, 4974, 4980, 4986, 4992, 4998, 5004, 5010, 5016, 5022, 5028, 5034, 5040, 5046, 5052, 5058, 5064, 5070, 5076, 5082, 5088, 5094, 5100, 5106, 5112, 5118, 5124, 5130, 5136, 5142, 5148, 5154, 5160, 5166, 5172, 5178, 5184, 5190, 5196, 5202, 5208, 5214, 5220, 5226, 5232, 5238, 5244, 5250, 5256, 5262, 5268, 5274, 5280, 5286, 5292, 5298, 5304, 5310, 5316, 5322, 5328, 5334, 5340, 5346, 5352, 5358, 5364, 5370, 5376, 5382, 5388, 5394, 5400, 5406, 5412, 5418, 5424, 5430, 5436, 5442, 5448, 5454, 5460, 5466, 5472, 5478, 5484, 5490, 5496, 5502, 5508, 5514, 5520, 5526, 5532, 5538, 5544, 5550, 5556, 5562, 5568, 5574, 5580, 5586, 5592, 5598, 5604, 5610, 5616, 5622, 5628, 5634, 5640, 5646, 5652, 5658, 5664, 5670, 5676, 5682, 5688, 5694, 5700, 5706, 5712, 5718, 5724, 5730, 5736, 5742, 5748, 5754, 5760, 5766, 5772, 5778, 5784, 5790, 5796, 5802, 5808, 5814, 5820, 5826, 5832, 5838, 5844, 5850, 5856, 5862, 5868, 5874, 5880, 5886, 5892, 5898, 5904, 5910, 5916, 5922, 5928, 5934, 5940, 5946, 5952, 5958, 5964, 5970, 5976, 5982, 5988, 5994, 6000, 6006, 6012, 6018, 6024, 6030, 6036, 6042, 6048, 6054, 6060, 6066, 6072, 6078, 6084, 6090, 6096, 6102, 6108, 6114, 6120, 6126, 6132, 6138, 6144, 6150, 6156, 6162, 6168, 6174, 6180, 6186, 6192, 6198, 6204, 6210, 6216, 6222, 6228, 6234, 6240, 6246, 6252, 6258, 6264, 6270, 6276, 6282, 6288, 6294, 6300, 6306, 6312, 6318, 6324, 6330, 6336, 6342, 6348, 6354, 6360, 6366, 6372, 6378, 6384, 6390, 6396, 6402, 6408, 6414, 6420, 6426, 6432, 6438, 6444, 6450, 6456, 6462, 6468, 6474, 6480, 6486, 6492, 6498, 6504, 6510, 6516, 6522, 6528, 6534, 6540, 6546, 6552, 6558, 6564, 6570, 6576, 6582, 6588, 6594, 6600, 6606, 6612, 6618, 6624, 6630, 6636, 6642, 6648, 6654, 6660, 6666, 6672, 6678, 6684, 6690, 6696, 6702, 6708, 6714, 6720, 6726, 6732, 6738, 6744, 6750, 6756, 6762, 6768, 6774, 6780, 6786, 6792, 6798, 6804, 6810, 6816, 6822, 6828, 6834, 6840, 6846, 6852, 6858, 6864, 6870, 6876, 6882, 6888, 6894, 6900, 6906, 6912, 6918, 6924, 6930, 6936, 6942, 6948, 6954, 6960, 6966, 6972, 6978, 6984, 6990, 6996, 7002, 7008, 7014, 7020, 7026, 7032, 7038, 7044, 7050, 7056, 7062, 7068, 7074, 7080, 7086, 7092, 7098, 7104, 7110, 7116, 7122, 7128, 7134, 7140, 7146, 7152, 7158, 7164, 7170, 7176, 7182, 7188, 7194, 7200, 7206, 7212, 7218, 7224, 7230, 7236, 7242, 7248, 7254, 7260, 7266, 7272, 7278, 7284, 7290, 7296, 7302, 7308, 7314, 7320, 7326, 7332, 7338, 7344, 7350, 7356, 7362, 7368, 7374, 7380, 7386, 7392, 7398, 7404, 7410, 7416, 7422, 7428, 7434, 7440, 7446, 7452, 7458, 7464, 7470, 7476, 7482, 7488, 7494, 7500, 7506, 7512, 7518, 7524, 7530, 7536, 7542, 7548, 7554, 7560, 7566, 7572, 7578, 7584, 7590, 7596, 7602, 7608, 7614, 7620, 7626, 7632, 7638, 7644, 7650, 7656, 7662, 7668, 7674, 7680, 7686, 7692, 7698, 7704, 7710, 7716, 7722, 7728, 7734, 7740, 7746, 7752, 7758, 7764, 7770, 7776, 7782, 7788, 7794, 7800, 7806, 7812, 7818, 7824, 7830, 7836, 7842, 7848, 7854, 7860, 7866, 7872, 7878, 7884, 7890, 7896, 7902, 7908, 7914, 7920, 7926, 7932, 7938, 7944, 7950, 7956, 7962, 7968, 7974, 7980, 7986, 7992, 7998, 8004, 8010, 8016, 8022, 8028, 8034, 8040, 8046, 8052, 8058, 8064, 8070, 8076, 8082, 8088, 8094, 8100, 8106, 8112, 8118, 8124, 8130, 8136, 8142, 8148, 8154, 8160, 8166, 8172, 8178, 8184, 8190, 8196, 8202, 8208, 8214, 8220, 8226, 8232, 8238, 8244, 8250, 8256, 8262, 8268, 8274, 8280, 8286, 8292, 8298, 8304, 8310, 8316, 8322, 8328, 8334, 8340, 8346, 8352, 8358, 8364, 8370, 8376, 8382, 8388, 8394, 8400, 8406, 8412, 8418, 8424, 8430, 8436, 8442, 8448, 8454, 8460, 8466, 8472, 8478, 8484, 8490, 8496, 8502, 8508, 8514, 8520, 8526, 8532, 8538, 8544, 8550, 8556, 8562, 8568, 8574, 8580, 8586, 8592, 8598, 8604, 8610, 8616, 8622, 8628, 8634, 8640, 8646, 8652, 8658, 8664, 8670, 8676, 8682, 8688, 8694, 8700, 8706, 8712, 8718, 8724, 8730, 8736, 8742, 8748, 8754, 8760, 8766, 8772, 8778, 8784, 8790, 8796, 8802, 8808, 8814, 8820, 8826, 8832, 8838, 8844, 8850, 8856, 8862, 8868, 8874, 8880, 8886, 8892, 8898, 8904, 8910, 8916, 8922, 8928, 8934, 8940, 8946, 8952, 8958, 8964, 8970, 8976, 8982, 8988, 8994, 9000, 9006, 9012, 9018, 9024, 9030, 9036, 9042, 9048, 9054, 9060, 9066, 9072, 9078, 9084, 9090, 9096, 9102, 9108, 9114, 9120, 9126, 9132, 9138, 9144, 9150, 9156, 9162, 9168, 9174, 9180, 9186, 9192, 9198, 9204, 9210, 9216, 9222, 9228, 9234, 9240, 9246, 9252, 9258, 9264, 9270, 9276, 9282, 9288, 9294, 9300, 9306, 9312, 9318, 9324, 9330, 9336, 9342, 9348, 9354, 9360, 9366, 9372, 9378, 9384, 9390, 9396, 9402, 9408, 9414, 9420, 9426, 9432, 9438, 9444, 9450, 9456, 9462, 9468, 9474, 9480, 9486, 9492, 9498, 9504, 9510, 9516, 9522, 9528, 9534, 9540, 9546, 9552, 9558, 9564, 9570, 9576, 9582, 9588, 9594, 9600, 9606, 9612, 9618, 9624, 9630, 9636, 9642, 9648, 9654, 9660, 9666, 9672, 9678, 9684, 9690, 9696, 9702, 9708, 9714, 9720, 9726, 9732, 9738, 9744, 9750, 9756, 9762, 9768, 9774, 9780, 9786, 9792, 9798, 9804, 9810, 9816, 9822, 9828, 9834, 9840, 9846, 9852, 9858, 9864, 9870, 9876, 9882, 9888, 9894, 9900, 9906, 9912, 9918, 9924, 9930, 9936, 9942, 9948, 9954, 9960, 9966, 9972, 9978, 9984, 9990, 9996, 10002, 10008, 10014, 10020, 10026, 10032, 10038, 10044, 10050, 10056, 10062, 10068, 10074, 10080, 10086, 10092, 10098, 10104, 10110, 10116, 10122, 10128, 10134, 10140, 10146, 10152, 10158, 10164, 10170, 10176, 10182, 10188, 10194, 10200, 10206, 10212, 10218, 10224, 10230, 10236, 10242, 10248, 10254, 10260, 10266, 10272, 10278, 10284, 10290, 10296, 10302, 10308, 10314, 10320, 10326, 10332, 10338, 10344, 10350, 10356, 10362, 10368, 10374, 10380, 10386, 10392, 10398, 10404, 10410, 10416, 10422, 10428, 10434, 10440, 10446, 10452, 10458, 10464, 10470, 10476, 10482, 10488, 10494, 10500, 10506, 10512, 10518, 10524, 10530, 10536, 10542, 10548, 10554, 10560, 10566, 10572, 10578, 10584, 10590, 10596, 10602, 10608, 10614, 10620, 10626, 10632, 10638, 10644, 10650, 10656, 10662, 10668, 10674, 10680, 10686, 10692, 10698, 10704, 10710, 10716, 10722, 10728, 10734, 10740, 10746, 10752, 10758, 10764, 10770, 10776, 10782, 10788, 10794, 10800, 10806, 10812, 10818, 10824, 10830, 10836, 10842, 10848, 10854, 10860, 10866, 10872, 10878, 10884, 10890, 10896, 10902, 10908, 10914, 10920, 10926, 10932, 10938, 10944, 10950, 10956, 10962, 10968, 10974, 10980, 10986, 10992, 10998, 11004, 11010, 11016, 11022, 11028, 11034, 11040, 11046, 11052, 11058, 11064, 11070, 11076, 11082, 11088, 11094, 11100, 11106, 11112, 11118, 11124, 11130, 11136, 11142, 11148, 11154, 11160, 11166, 11172, 11178, 11184, 11190, 11196, 11202, 11208, 11214, 11220, 11226, 11232, 11238, 11244, 11250, 11256, 11262, 11268, 11274, 11280, 11286, 11292, 11298, 11304, 11310, 11316, 11322, 11328, 11334, 11340, 11346, 11352, 11358, 11364, 11370, 11376, 11382, 11388, 11394, 11400, 11406, 11412, 11418, 11424, 11430, 11436, 11442, 11448, 11454, 11460, 11466, 11472, 11478, 11484, 11490, 11496, 11502, 11508, 11514, 11520, 11526, 11532, 11538, 11544, 11550, 11556, 11562, 11568, 11574, 11580, 11586, 11592, 11598, 11604, 11610, 11616, 11622, 11628, 11634, 11640, 11646, 11652, 11658, 11664, 11670, 11676, 11682, 11688, 11694, 11700, 11706, 11712, 11718, 11724, 11730, 11736, 11742, 11748, 11754, 11760, 11766, 11772, 11778, 11784, 11790, 11796, 11802, 11808, 11814, 11820, 11826, 11832, 11838, 11844, 11850, 11856, 11862, 11868, 11874, 11880, 11886, 11892, 11898, 11904, 11910, 11916, 11922, 11928, 11934, 11940, 11946, 11952, 11958, 11964, 11970, 11976, 11982, 11988, 11994, 12000, 12006, 12012, 12018, 12024, 12030,

BAXENDALE & CO. LTD.

GALVANIZED TANKS, CISTERNS AND CYLINDERS
RIVETED OR WELDED TESTED AND GUARANTEED SOUND TO
CONFORM TO B.S. No. 417-1951

The main details are as follows—

CISTERNS (Welded or Riveted)	NOMINAL CAPACITY	GRADE A	GRADE B
		Minimum Thickness of Steel before Galvanizing	
10 Galls. up to 30 Galls. incl.		10 B.G.	18 B.G.
30 " " " 100 " "		14 B.G.	16 B.G.
100 " " " 200 " "		12 B.G.	14 B.G.
200 " " " 300 " "		1"	12 B.G.
300 " " " 1000 " "		1 1/2"	1"

Grade A Cisterns are usually required by Water Authorities for use in connection with Public Water supplies.

HOT WATER TANKS (Welded or Riveted)	GRADE A	GRADE B
	Test Pressure : 70 lb. per sq. in. Max. Working Head of Water : 15 ft.	Test Pressure : 7 1/2 lb. per sq. in. Max. Working Head of Water : 10 ft.
ACTUAL CAPACITY		Minimum Thickness of Steel before Galvanizing
17 Galls. up to 45 Galls. incl. 55 Galls.		1" 1 1/2"
		12 B.G. 1"

HOT WATER CYLINDERS (Welded or Riveted)	GRADE A	GRADE B	GRADE C
	Test Pressure : 70 lb. per sq. in. Max. Working Head of Water : 100 ft.	Test Pressure : 40 lb. per sq. in. Max. Working Head of Water : 60 ft.	Test Pressure : 20 lb. per sq. in. Max. Working Head of Water : 30 ft.
ACTUAL CAPACITY		Minimum Thickness of Steel before Galvanizing for both Bodies and Dished Ends	
16 Galls. up to 35 Galls. inclusive	1"	12 B.G.	14 B.G.
36 Galls. up to 57 Galls. inclusive	1 1/2"	1"	12 B.G.

The permissible Working Head shall be measured from the bottom of the Tank or Cylinder to the flow pipe of Cisterns.

SIZE OF SCREWED CONNECTIONS All Grades

	Tanks	Cylinders
1 1/2"	17-27 Galls. inclusive	10-27 Galls. inclusive
1"	14-31 " " "	17-31 " " "
3/4"		21-37 " " "

Handholes of not less than 6" in diameter must be fitted to all Tanks and Cylinders.

We have large stocks in all sizes from 6 galls. to 1000 galls. and will be pleased to send prices.

LIVERPOOL · EDINBURGH · DUBLIN

GUN METAL STEAM VALVES AND COCKS



No. B 3150
WHEEL VALVE
Globe Pattern.
For steam pressures
up to 150 lbs. □"
Sizes : ¼ in. to 4 in.



No. B 3152
WHEEL VALVE
Screwed cover pattern
with renewable nickel
alloy clack and seat.
For steam pressures
up to 200 lbs. □" and
a total superheat
temp. of 500° F.
Sizes : ¼ in. to 2 in.



No. B 3154
WHEEL VALVE
With renewable
composition disc.
For steam pressures
up to 150 lbs. □".
Sizes : ¼ in. to 4 in.



No. B 3215
STEAM PLUG
COCK
Sizes : ¼ in. to 2 in.

**GUN METAL
STEAM COCKS**

All screwed
female ends

Nos. B 3215, 3219,
3221 for pressures up
to 150 lbs. □"

No. B 3223 for pres-
sures up to 200 lbs.
□"

All screwed Cocks and
Valves can be supplied
flanged (*Extra*).



No. B 3223
STEAM GLAND
COCK
Asbestos packed.
Sizes : ½ in. to 2 in.



No. B 3221
STEAM GLAND
COCK
Sizes : ¼ in. to 2 in.



No. B 3219
THREE-WAY
STEAM PLUG COCK
Sizes : ½ in. to 2 in.

STEAM FITTINGS

No. B 3359

LOCO. FUSIBLE PLUG

Low pressure type : for pressures up to 100 lbs. per \square ".

High pressure type : for pressures above 100 lbs. per \square ".



Size	Gas thread on seating
00	$\frac{3}{4}$ in.
0	1 in.
1	$1\frac{1}{4}$ in.

No. B 3361

IMPROVED VALVE SEATED FUSIBLE PLUG

Low pressure type : for pressures up to 100 lbs. per \square ".

High pressure type : for pressures above 100 lbs. per \square ".



Size	Gas thread on seating
00	$\frac{3}{4}$ in.
0	1 in.
1	$1\frac{1}{4}$ in.
2	$1\frac{1}{2}$ in.
3	2 in.



No. B 3171

WHEEL VALVE

Fullway Gate Pattern. Strong type for hydraulic pressures up to 200 lbs. \square "

All Sizes $\frac{1}{4}$ in. to 4 in.



No. B 3214

THROTTLE VALVE

Gun Metal

With index plate.

Screwed female iron.

Sizes : $\frac{3}{4}$, 1, $1\frac{1}{4}$, $1\frac{1}{2}$ in.

GUN METAL STEAM CHECK VALVES

Screwed female ends.



No. B 3260
Horizontal
All Sizes
 $\frac{1}{4}$ to 3 in.



No. B 3262
Vertical
All Sizes
 $\frac{1}{4}$ to 3 in.

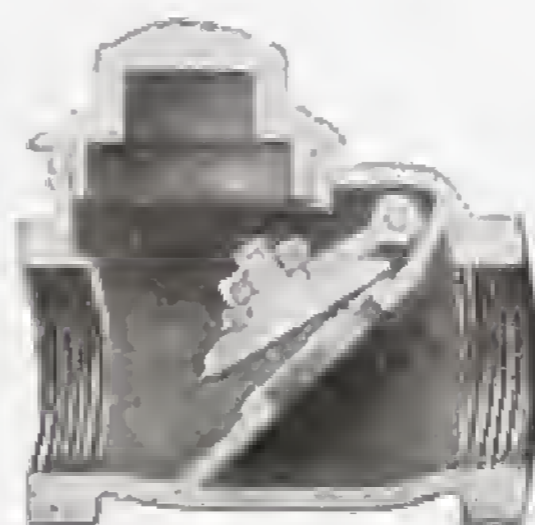

No. B 3264
Swing
All Sizes
 $\frac{1}{4}$ to 3 in.



No. B 3266
Angle
All Sizes
 $\frac{1}{2}$ to 2 in.

BAXENDALE & CO. LTD.

RADIATOR VALVES Sizes $\frac{1}{2}$ in. to $1\frac{1}{2}$ in.



No. B 4116
Angular
With Union.



*Valves can be supplied with
indichords at same prices
at composition wheels.
Keys extra.*



No. B 4117
Straight
With Union.



No. B 3200
Angular With Union.



No. B 3202
Angular
Screwed female ends.



No. B 3204
Straight
With Union.



No. B 3677
Straight Union.

RADIATOR UNIONS

*These unions have
screwed male and
female ends.*

Sizes: $\frac{1}{2}$ in. to $1\frac{1}{2}$ in.



No. B 3676
Elbow Union.



No. B 4119
Smooth-body Straight Union.

No. B 4116, B 4117, B 4118, and B 4119 are supplied in polished brass or chromom-plated finish.



No. B 4118
Smooth-body Elbow Union.

MILLER STREET - MANCHESTER

GUN METAL DRAIN COCKS, ETC.



No. B 3328
Drain Cock.

Sizes : $\frac{1}{8}$, $\frac{1}{4}$, $\frac{3}{8}$, $\frac{1}{2}$, $\frac{3}{4}$ in.



No. B 3322
Drain Cock.

Sizes : $\frac{1}{8}$, $\frac{1}{4}$, $\frac{3}{8}$, $\frac{1}{2}$, $\frac{3}{4}$ in.

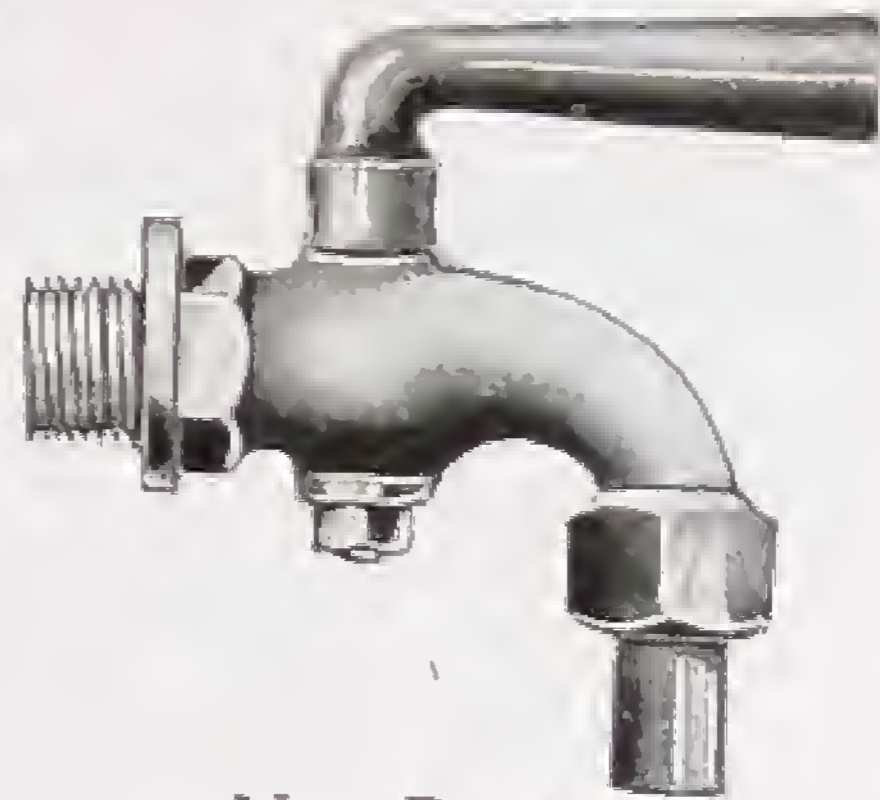

No. B 3324
Drain Cock
with Union on Nose.
Sizes : $\frac{1}{4}$, $\frac{3}{8}$, $\frac{1}{2}$, $\frac{3}{4}$ in.



No. B 3326
Drain Cock
with Union.

Sizes : $\frac{1}{8}$, $\frac{1}{4}$, $\frac{3}{8}$, $\frac{1}{2}$, $\frac{3}{4}$, 1 in.

No. B 3216. PIPE CHECKER

With butterfly valve.

A knurled lock nut is provided to fasten in position when set.

Screwed for iron or copper pipes.

All Sizes : $\frac{1}{2}$ in. to 3 in.

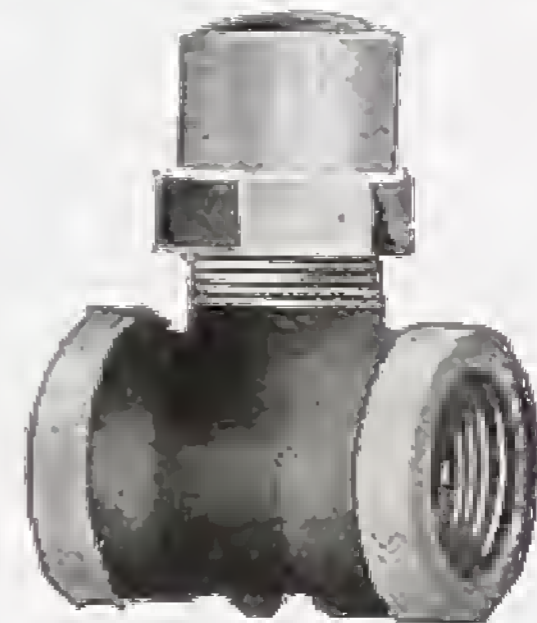

PENBERTHY PATTERN SILENT WATER HEATER

All Gun Metal.

Suitable for heating any liquid quickly and silently. Used for boiling water in chemical works, breweries, creameries, laundries, hotels, etc.



No. B 3218

Size of heater	F	G	H	J	K	L	M	N	
Size of steam pipe	$\frac{1}{4}$	$\frac{3}{8}$	$\frac{1}{2}$	$\frac{3}{4}$	1	1 $\frac{1}{4}$	1 $\frac{1}{2}$	2	in.
" delivery pipe	$\frac{1}{2}$	1	1 $\frac{1}{4}$	1 $\frac{1}{2}$	2	2 $\frac{1}{2}$	3	4	"
Galls. of water heated per hour from 70° to 210° F. with 70 lbs. steam press...	100	120	150	200	250	350	500	1,000	



No. B 3220

SECTIONAL PIPE COVERING

85% Magnesia.

Canvas backed and complete with metal fixing bands. Supplied in lengths of 3 ft.

For wrought iron pipes and copper tubes.

All Sizes : $\frac{1}{2}$ in. to 6 in.

RADIATOR AIR VALVES



No. B 3330
With Loose Key
All Nickel or Chromium-plated.



No. B 3331
With Loose Key
All Nickel or Chromium-plated.



No. B 3334
With Compression Wheel
Sizes 1/2 in. and 3/4 in.



No. B 3344. **AUTOMATIC AIR VALVE**
For Steam Radiators and Coils. Nickel plated. Screwed 1 in. Gas.
Before fitting, loosen screw (B), then fit the valve, and when the radiator becomes too tight, the screw gradually until there is no escape of steam at outlet (D). Then screw on the cap tightly to prevent interference with the adjustment.
Drop cap to screw at outlet, extra. Extra composition plug can be supplied.

THERMOMETERS, Fabr. or Cent.



No. B 3410
Brass Case Straight

No. B 3417
Angle Pattern

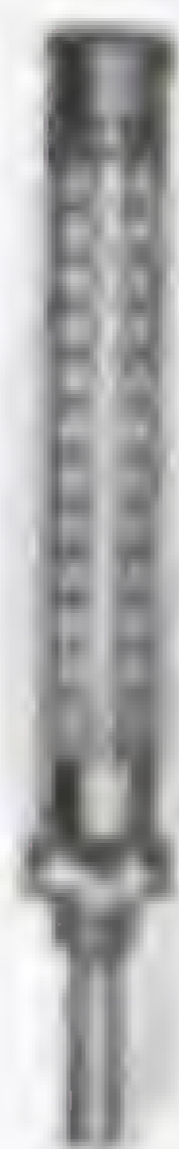

No. B 3420
Brass Case Straight
Also with revolving scale

No. B 3422
Angle Pattern

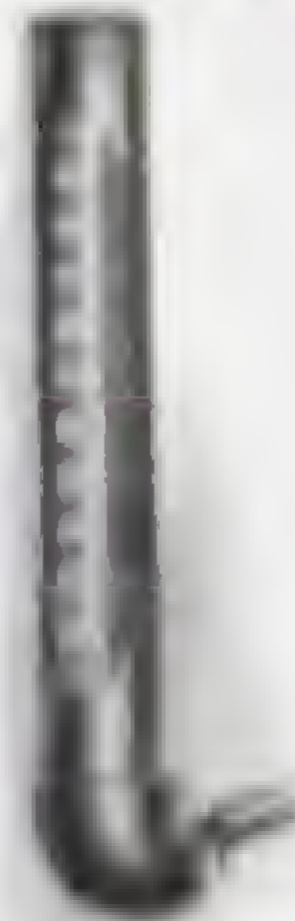

No. B 3424
COMBINED ALTITUDE GAUGE and THERMOMETER

Graduated up to 50 ft.
Screwed 1/2 in. gas thread

No. B 3425
ALTITUDE GAUGE
Graduated up to 50 ft. unless otherwise ordered.
Screwed 1/2 in. gas thread



No. B 3419
Brass Case
Angle, Right or
Left hand

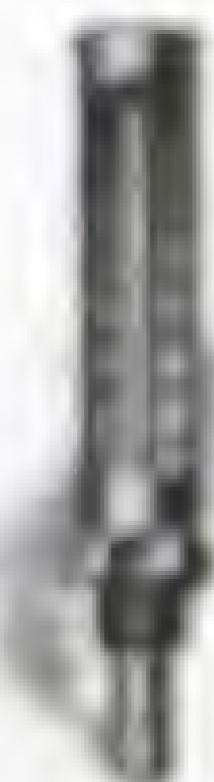

No. B 3416
Brass Case Straight



GAUGE GLASSES

PLAIN GAUGE GLASS
With fused or ground ends.

No. B 3388 Ordinary Quality.
No. B 3389 High Pressure Quality.

No. B 3390

ENAMELLED GAUGE GLASS

With white, or red and white stripe; Fused Ends
The Enamelled Gauge Glasses are particularly useful in dark places as they show at a glance the Water level in the Boiler, which can be seen **AS PLAINLY** by night as by day.

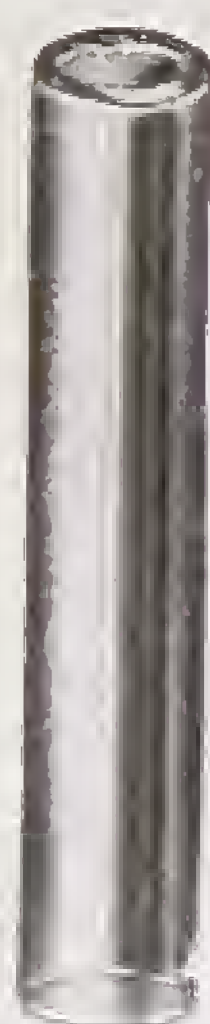

SAFETY AND VACUUM VALVES

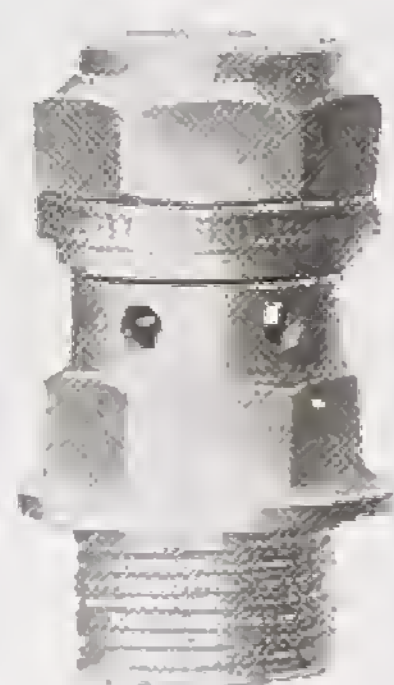

No. B 2931

SPRING SAFETY VALVE

Hot Pressed Brass
Phosphor bronze spring.
Set to blow off at 30 lbs. per \square "
Sizes: $\frac{1}{2}$, $\frac{3}{4}$, 1 in.



No. B 3353
SPRING SAFETY VALVE

Gun Metal
Open Discharge Type.
Can be set to blow off at any pressure up to 150 lbs. per \square "
All Sizes: $\frac{1}{2}$ in. to 3 in.



No. B 2930
SAFETY VALVE

Hot Pressed Brass
Dead Weight Type.
Weighted to 32 lbs.
Sizes: $\frac{1}{2}$, $\frac{3}{4}$, 1 in.



No. B 2933

SPRING SAFETY VALVE

Hot Pressed Brass
Phosphor bronze spring.
Set to blow off at 50 lbs. per \square " or can be specially made to blow off at 50 lbs. per \square ".
Also supplied graduated on spindle to order.

Sizes: $\frac{1}{2}$, $\frac{3}{4}$, 1 in.



No. B 2934
VACUUM VALVE

Gun Metal
All Sizes: $\frac{1}{2}$ in. to 2 in.



No. B 2932
SAFETY VALVE

Gun Metal Body
Dead Weight Type.
Weighted to 33 lbs.
All Sizes: $\frac{3}{4}$ in. to 2 in.



No. B 3351

REDUCING VALVE

Suitable for boiler pressures up to 175 lbs. per sq. in. and reduced pressures down to 5 lbs. per sq. in.

Sizes up to and including 1½ in., made in gun metal throughout.

All sizes are advisedly made with flanges so that the valve can be readily dropped out for repair. ½ in., ¾ in. and 1 in. are also supplied with screwed ends when required.

When ordering give the Boiler Pressure and the Highest Reduced Pressure desired.

SPECIAL FEATURES :

An efficient Reducing Valve—no liability to “stick.”
Reduced pressure easily varied by hand wheel.

Sizes : ½, ¾, 1, 1¼, 1½, 2, 2½, 3 in.

No. B 3357 NATIONAL SAFETY VALVE

Size	Size of Inlet and Outlet B.S.P.	Radiating capacity of boiler for which valve is suitable	
		B.T.U. Water	B.T.U. Steam
17	½ in.	100,000	
18	¾ in.	900,000	80,000
19	1 in.	1,200,000	160,000
20	1¼ in.	1,500,000	260,000
21	1½ in.	1,800,000	400,000
22	2 in.	2,800,000	700,000
23	2½ in.	3,800,000	1,100,000
24	3 in.	Above 3,800,000	1,700,000



Spring Loaded, for water, steam or air.

No. B 3356 NATIONAL ENCLOSED SAFETY VALVE

For Hot Water Boilers.



Series No.	Socket Screwed B.S.P.	Suitable for Radiating Capacity B.T.U.
1	¾ in.	100,000
2	1 in.	450,000
X3	1¼ in.	900,000
3	1 in.	1,200,000
X4	1½ in.	1,500,000
4	1¾ in.	1,800,000



No. B 3374

GUN METAL TANK GAUGE

Screwed $\frac{1}{2}$ in. Male iron.

No. B 3380

GUN METAL WATER GAUGE

Round barrel pattern. Screwed or flanged ends.

Sizes : $\frac{3}{8}$, $\frac{1}{2}$, $\frac{5}{8}$, $\frac{3}{4}$ in.

When ordering please state distance centre to centre of holes in boiler.

For glass tubes only, see Page 179

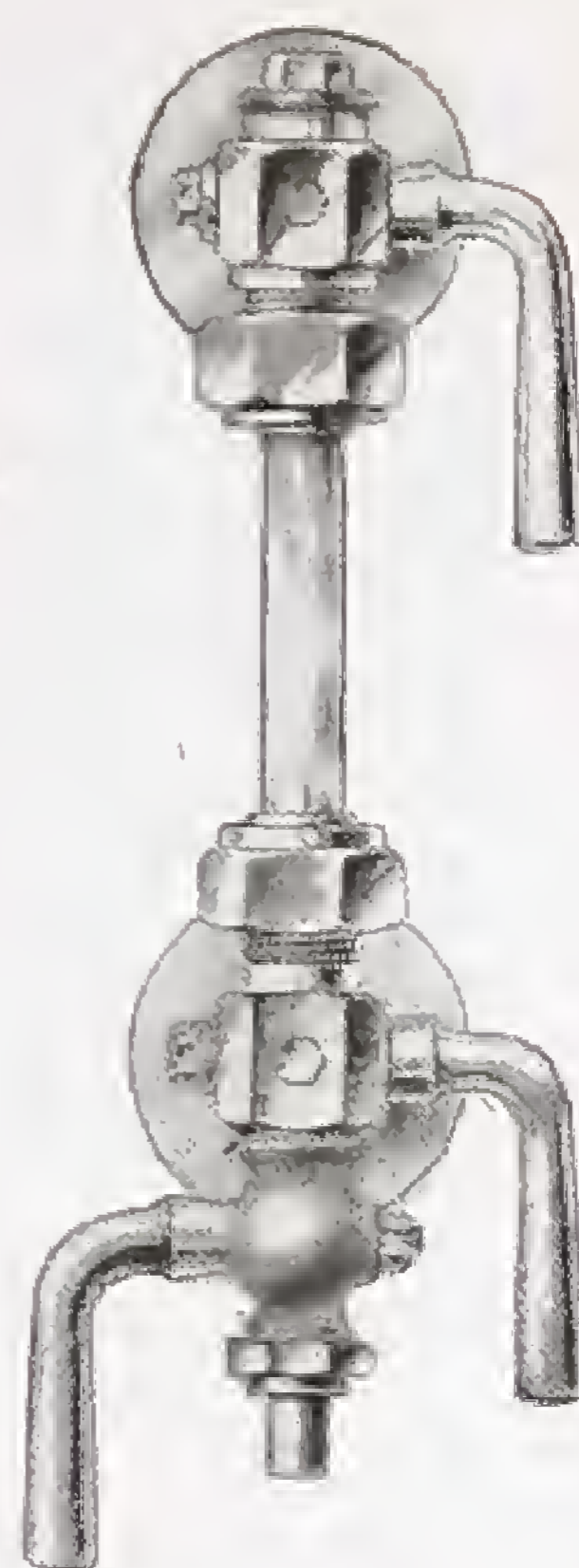

No. B 3400

BOURDON PRESSURE GAUGE

Bevelled edge plate glass front.

To Register over 20 and under 400 lbs. per \square ".

Sizes 3 in. to 8 in. screwed $\frac{3}{8}$ in. gas.

„ 9 in. & 10 in. „ $\frac{1}{2}$ in. „

Diam. of dial—

3 4 5 6 7 8 9 10 in.



No. B 3400

We also supply Vacuum Gauges, Compound Gauges, and Traction Engine Gauges, etc.



No. B 3413

WROUGHT-IRON SIPHON

With brass gauge cock.
Sizes : $\frac{3}{8}$ and $\frac{1}{2}$ in.



No. B 3414

BRASS GAUGE COCK

With nut and tail pipe.
Sizes : $\frac{3}{8}$ and $\frac{1}{2}$ in.



No. B 3415

BRASS GAUGE COCK

Wood handle.
Female ends.
Sizes : $\frac{3}{8}$ and $\frac{1}{2}$ in.



No. B 1186

WATER GAUGE GLASS PROTECTORS
With three glass sides.

To fit runs up to 2 1/2 in. across valves
(also supplied to fit larger runs; prices on application.)

When ordering please state the distance at A, and the distance across (inside, not flange) of the Glass Plate at C, and depth of Flange at B.



NOTE.—When ordering, if the Side Bolt Flange are close to the Water Gauge Glasses send us a sketch showing position and distance from Glass to Flange, both ways.

No. B 1186 SIZES

Clear distance between front of stuffing boxes A	5	7	8	9	10	11	12	13	14
Clear distance between tops of stuffing boxes B	14	15	16	17	18	19	20	21	22

When ordered plain for back run also be supplied.



No. B 1192



No. B 1196



No. B 1194

INDIA-RUBBER GAUGE WASHERS

- B 1192 Round Pattern
- B 1194 Square
- B 1196 Central

All above to suit glasses 1/2 in. to 1 1/2 in. diam.
Special sizes quoted for an application.
When ordering give serial diam. of glass.

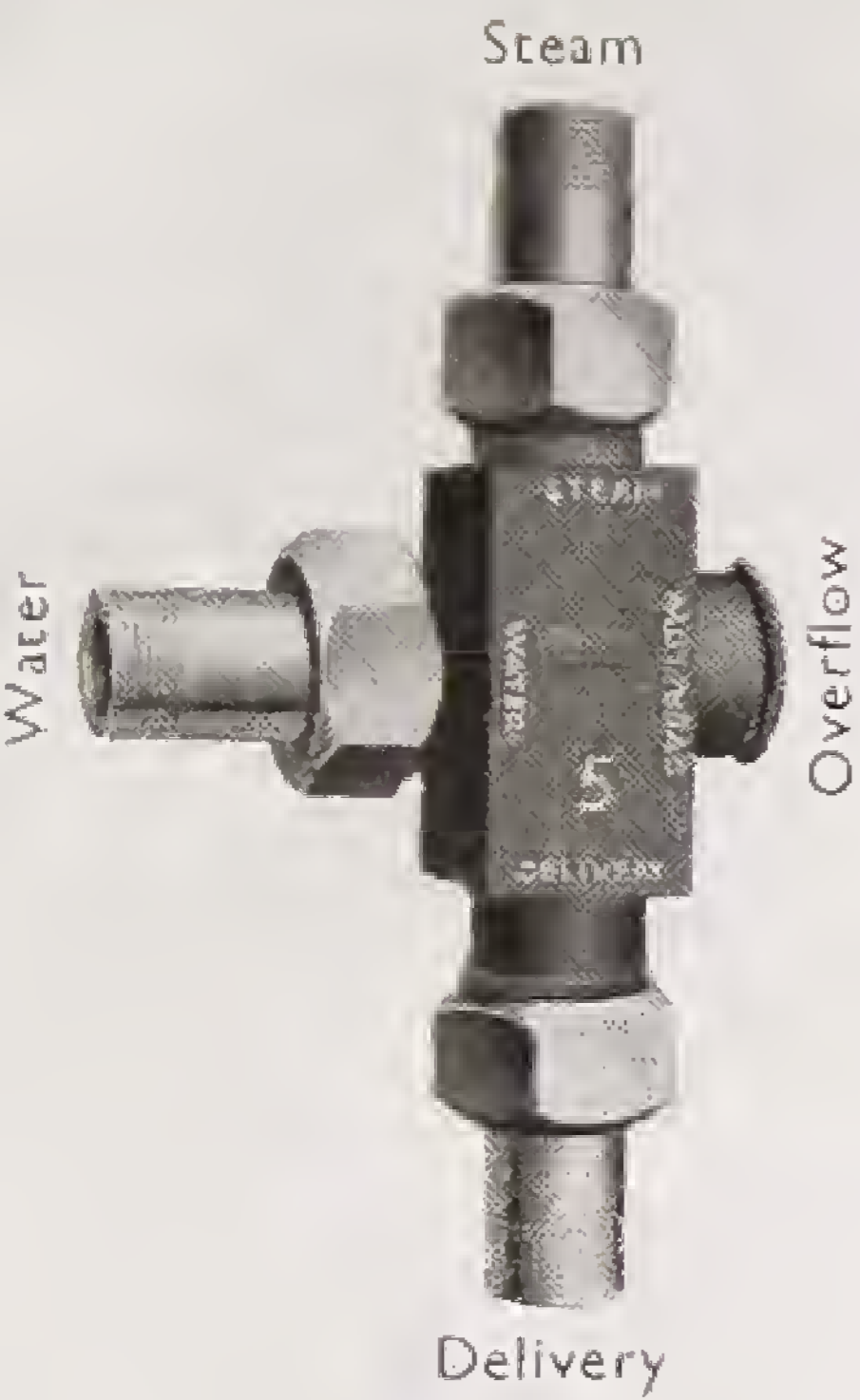

No. B 3345
**SELF-ACTING
RESTARTING
INJECTOR**

May be fixed vertically or horizontally

No. B 3346
EJECTOR

Suitable for filling and emptying tanks, raising and transferring liquids, etc.



No. B 3345
AUTOMATIC INJECTOR
Gunmetal

Size No.	Pipe Sizes	Maximum Capacities Feed 60°F., Lift 3 feet		
		30 lbs./sq. in.	50 lbs./sq. in.	100 lbs./sq. in.
	In.	Galls./hour	Galls./hour	Galls./hour
2	3/4	35	45	73
2 1/2	1	60	80	110
3	1 1/4	95	125	180
4	1 1/2	175	225	315
5	1 3/4	270	350	495
6	2	390	505	715
7	2 1/4	530	690	970
8	2 1/2	695	895	1270
9	3	880	1135	1610
10	4	1085	1405	1985

No. B 3346
AUTOMATIC EJECTOR

Size No.	Pipe Sizes		Capacities			Steam Required At 60 lbs./sq. in.
	Steam Pipe	Suction and Discharge	Steam Pressure, 40 to 65 lbs./sq. in.			
			3 feet Lift	25 feet Elevation	50 feet Elevation	
	In.	In.	Galls./hour	Galls./hour	Galls./hour	Lbs./hour
1	3/4	1/2	250	175	120	48
2	1	3/4	500	380	250	90
3	1 1/4	1	850	650	400	155
4	1 1/2	1 1/4	1300	925	650	235
5	1 3/4	1 1/2	1900	1500	970	350
6	2	2	3500	2600	1750	700
7	2 1/4	2 1/2	5700	3700	2500	950
8	3	3	9500	7200	4750	2000

No. B 3474

WELLDECK STEAM TRAP

With uncrushable diaphragm, suitable for all pressures from zero to 130 lbs. per \square in.

It is foolproof, self-venting is wide open when cold, is easily adjustable and there can be no airlock, hammering, or vacuum in the pipeline when it is fitted.



Size B.S.P.	Discharge G.P.H. when set for 120 lbs. \square " Water at 60° F.	Length
$\frac{1}{2}$ in.	120	3 $\frac{1}{2}$ in.
$\frac{3}{4}$ in.	200	4 $\frac{1}{2}$ in.
1 in.	400	5 in.
1 $\frac{1}{4}$ in.	670	6 $\frac{1}{2}$ in.
1 $\frac{1}{2}$ in.	1130	8 in.
1 $\frac{3}{4}$ in.	2000	8 in.
2 in.	3000	8 in.

No. B 3477

PIPELINE STRAINER

Designed for easy cleaning and to last indefinitely. The strainer element is fitted to permit the removal of the cleaning plug without the element being disturbed.

Constructed of gunmetal.

Sizes: $\frac{1}{2}$, $\frac{3}{4}$, 1, 1 $\frac{1}{4}$, 1 $\frac{1}{2}$, 2 in.



No. B 3478

SPIRAX STEAM TRAP

Low Pressure Pattern for steam pressures up to 15 lbs. per \square ".

High Pressure Pattern for steam pressures up to 40 lbs. per \square ".

A small well-constructed trap especially useful for radiators.

Thermostatic element and valve can be easily removed.



Size B.S.P.	Pattern	Discharge Capacities in lbs. per hour	
		at 40 P.S.I.	at 15 P.S.I.
$\frac{1}{2}$ in.	Angle	910	760
$\frac{3}{4}$ in.	Straight		
1 in.	Angle		
1 $\frac{1}{4}$ in.	Straight		

BAXENDALE & CO. LTD.

No. B 3473

INVERTED BUCKET TYPE STEAM TRAPS

For Pressures up to 125 lbs. □"

These traps are suitable for draining small unit heaters, radiators, small coils, jacketed pans, sterilizers, coffee urns, tea boilers, small calorifiers and coil heated tanks, small ironers and similar applications where an efficient, sharp-acting, automatic air-venting and reliable trap is required.

Bodies are of cast-iron, buckets brass; valves and seats are made from chrome steel alloy, heat treated and stainless.

Where large quantities of air have to be discharged at frequent intervals, traps with thermic-strip air-vent should be specified. (Extra)

The capacities given represent the continuous discharge capacities of the traps; a safety factor of 2 or 3, according to conditions, should be allowed to arrive at the normal working capacity.

Screwed ½ in. B.S.P.T.



Pressure pounds per □"	Capacities pounds per hour	Pressure pounds per □"	Capacities pounds per hour	Pressure pounds per □"	Capacities pounds per hour
5	460	40	550	90	630
10	570	50	590	100	640
15	640	60	620	110	650
20	690	70	660	120	660
25	460	75	675	125	665
30	500	80	690		

No. B 3476

SPIRAX BALL FLOAT STEAM TRAPS

Type FT 51

for steam pressures up to 200 □"

Type FT 52

for steam pressures up to 120 □"

Type FT 53

for steam pressures up to 60 □"

Construction

Body of malleable iron with face plate of pressed non-ferrous alloy; ball float, main valve and seat of stainless steel; liquid-expansion type air release with valve and seat of stainless steel.

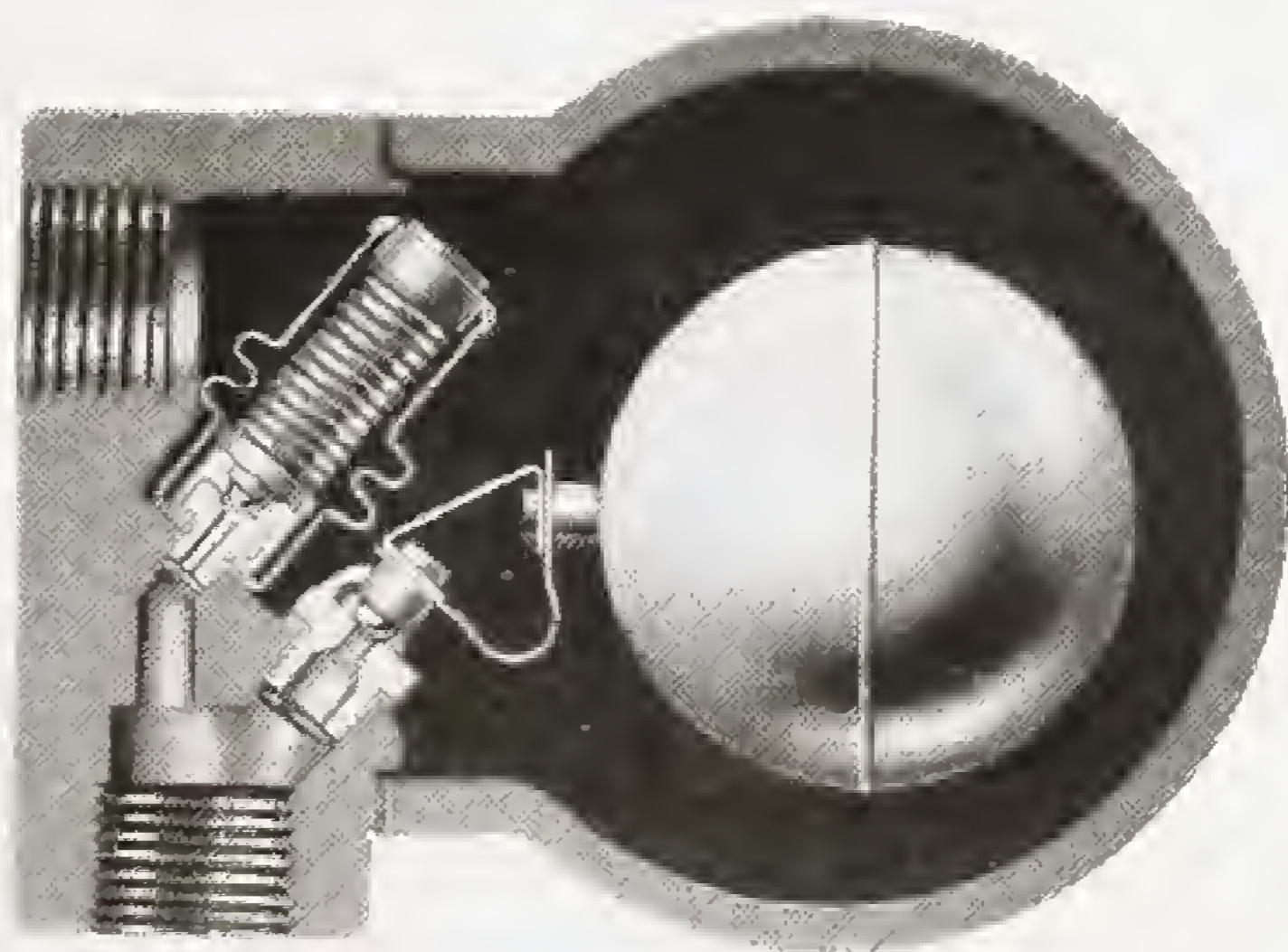

Size of Connections and Pattern No.	Pressure lb./sq. in.	Discharge Capacity lb./hour	Weight	Length in.
1 in. } FT-51	0-200	555	} 4 lb. 5 oz.	5 6/16
1 in. } FT-52	0-120	881		
1 in. } FT-53	0-60	1370		

LIVERPOOL · EDINBURGH · DUBLIN

No. B 3571

**ZENITH
HIGH-PRESSURE
VALVE TWIST
PACKING**

Used for the packing of valve spindles or for stuffing boxes where the packing section is small. Will withstand very high pressures.

Supplied in 1-lb. spools. Boxed.

Sizes: $\frac{1}{16}$ in. and upwards.



No. B 3572

**LOMOTO
HIGH-PRESSURE
STEAM PACKING**

Is primarily designed to withstand the highest superheated steam temperatures and pressures, but it can also be used as a packing against either alkalies or weak acids.

Supplied in 7-lb. boxes.

Round or square section.

Sizes: $\frac{1}{4}$ in. and upwards.



No. B 3602.

ASBESTOS YARN

Can be used for the lagging of small pipes, as a low pressure packing, and as a jointing medium in patent glazing etc.

Supplied 1 ply and upwards.



PACKINGS



No. B 3581
**ASBESTOS IMPERIAL
 BLOCK PACKING**
 For high-pressure steam.
 Supplied in 60-ft. coils.
 Sizes $\frac{1}{4}$ -in. sq. and upwards.

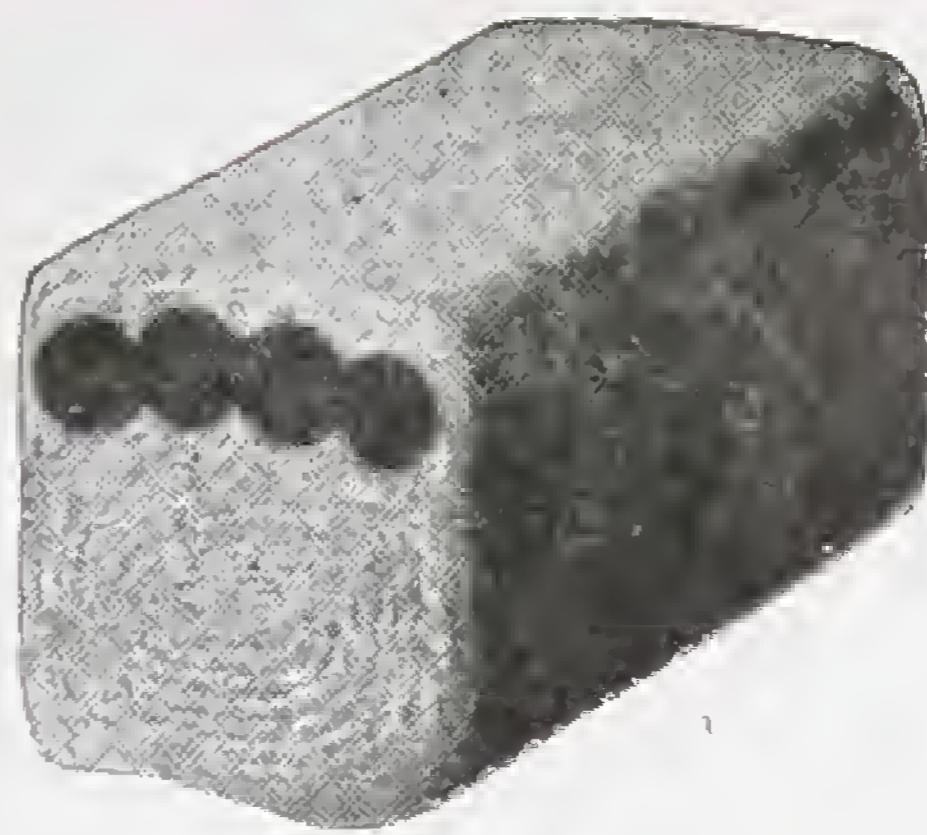

No. B 3582
**ASBESTOS MULTICORE
 PACKING**
 For high-pressure steam.
 Supplied in 60-ft. coils.
 Sizes : $\frac{1}{4}$ -in. sq. and upwards.

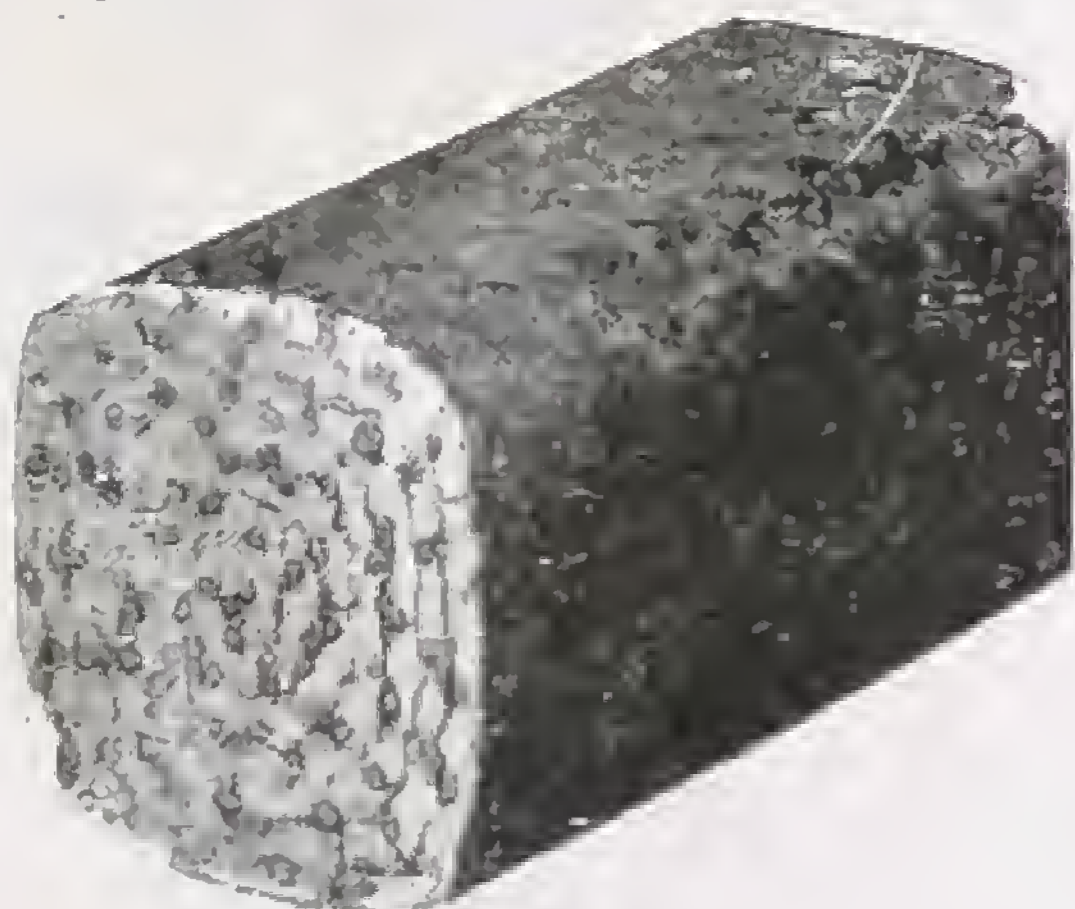

No. B 3584
**ASBESTOS AND
 WHITE METAL CLOTH
 PACKING (GRAPHITED)**
 Supplied in 60-ft. coils.
 Sizes : $\frac{1}{4}$ -in. sq. and upwards.

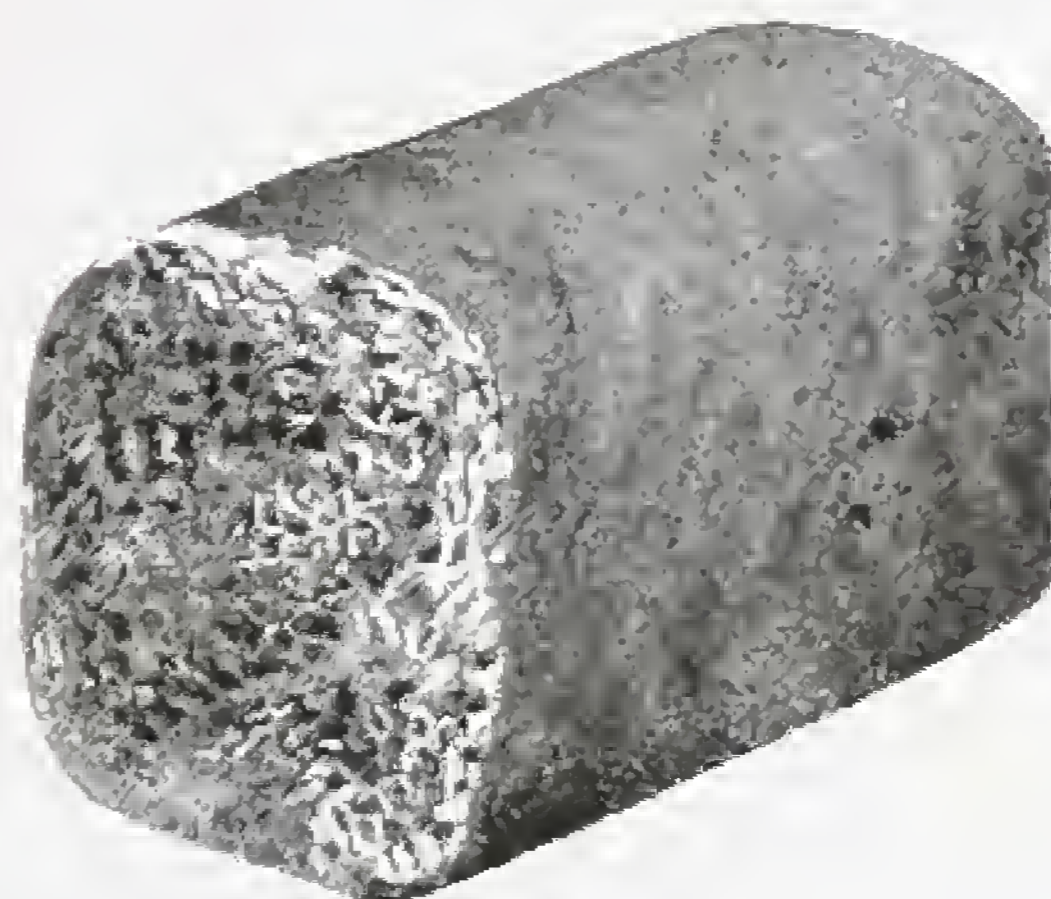

No. B 3592
**LUBRICATED HYDRAULIC
 PACKING**
 X and XX Quality.
 Sizes : $\frac{1}{4}$ -in. sq. and upwards.
 7 to 28 lb. coils according to size.
 X quality XX quality (White)



No. B 3573
**COTTON PARAGON
 PACKING**
 Particularly suitable for hot water.
 Sizes : $\frac{1}{4}$ -in. sq. and upwards.
 Supplied in 12-ft. coils.



No. B 3574
**CANVAS PACKING WITH
 RUBBER CORE**
 X and XX Quality.
 Sizes : $\frac{1}{4}$ -in. and upwards.
 Supplied in 60-ft. coils.

The following can also be supplied :
 No. B 3576. **ASBESTOS PLAITED PACKING**
 Plaited throughout.



No. B 3552

**BEANCO COMPRESSED ASBESTOS
FIBRE JOINTING**

(British made)

Suitable for all pressures up to 250 lbs. per sq. in.
Can be supplied any thickness from
 $\frac{1}{32}$ -in. upwards. Red Colour.

In sheets 40-in. x 40-in., 48-in. x 48-in., and
60-in. x 60-in.

No. B 3554

CORRUGATED METALLIC PACKING RINGS

In Brass, Copper, or Nickel,
for Joints of all Shapes and Sizes.

In making a joint, one of the corrugated rings is laid along with the cement on the inner part of surface of the flange, clear of the bolts. In screwing up the joint, the ridges of the corrugations yield to it, and take the impressions of all the irregularities on the surfaces of the flanges, thus making it impossible for any ordinary high pressure from either steam or water to penetrate the joint.

PRICE OF RINGS

Rings are charged at the rate of **One Penny per inch** of the inside diameter, *subject to current plusages*, the following width of flange being allowed:—

Inside diameter	$\frac{1}{2}$ in. to 3 in.,	Rim allowed 1 in. each side.
"	" above 3 in. to 5 in.,	Rim allowed $1\frac{1}{2}$ in. each side.
"	" above 5 in. to 9 in.,	Rim allowed $1\frac{1}{2}$ in. each side.
"	" above 9 in.,	Rim allowed 2 in. each side.

All above these sizes of Rims charged as extra measurement on the inside diameter of Ring, and if the Rings are very wide and combine two of our ordinary sizes, we charge then 1 in. off the outside diameter of Ring.

Rings are manufactured up to any size or design.

Price of Squares, Oblongs, and all Special Shaped Joints on application.

In ordering Rings, please state inside diameter of pipe, and inside diameter between bolts of flange. If the Rings are required to cover the entire breadth of flange, please give the inside and outside diameter of the Rings, the number and size of bolt holes and the pitch circle.

In ordering Ovals, Oblongs, and Squares, give also inside width and length, and outside measurements.



PACKINGS, Etc.

We also supply Jenkins' and Hallite packings. Prices on application.
Packing rings and joints in any shape and thickness supplied to order.



No. B 3600

BEST SHEET RUBBER

With or Without Insertion,
for Washers or Cistern Valves.

and

RUBBER STEAM SHEETING



No. B 3594

PROOFED ASBESTOS TAPE

Sizes : $\frac{1}{2}$ in. \times $\frac{1}{8}$ in. and upwards.

Supplied in 100-ft. coils.

No. B 3598

PROOFED ASBESTOS SHEETING

In rolls 40/42 in. wide.

Thickness $\frac{1}{16}$ in. and upwards.



No. B 3596

PROOFED ASBESTOS RINGS

Standard manhole and mudhole sizes.

2-in. and up to 8-in. inside dia. with not less than $\frac{1}{2}$ -in. flange \times $\frac{1}{8}$ -in. thick. From 8-in. to 18-in. inside dia. with not less than 1-in. flange \times $\frac{1}{8}$ -in. thick.

ASBESTOS MILLBOARD

In sheets 40 \times 40 in.

Thickness $\frac{1}{32}$ in. to $\frac{1}{2}$ in.

Other size sheets to order (extra).

Other Asbestos Products supplied include the following :

ASBESTOS FIBRE-FILLED ROPE LAGGING

Supplied in 100-ft. coils.

NON-METALLIC AND METALLIC CLOTHS

Woven in 45-yard rolls.

CLOTHS

CONTAINING WHITE-METAL WIRE

Woven in 25-yard rolls.

UNION CLOTHS

Woven in 50-yard rolls.

Standard width of above 40/42 in.

ASBESTOS WOVEN WEBBING

Suitable for the lagging of pipes carrying steam and hot liquids, for the wrapping of exhaust pipes and for certain classes of electrical installation. This material is supplied in widths from $\frac{1}{2}$ -in. to 12-in. and in thicknesses from $\frac{1}{32}$ -in. to $\frac{3}{16}$ -in. The length of the roll depends upon the thickness of the webbing.

No. B 3604
RUBBER WASHERS

Steam quality.

All Sizes

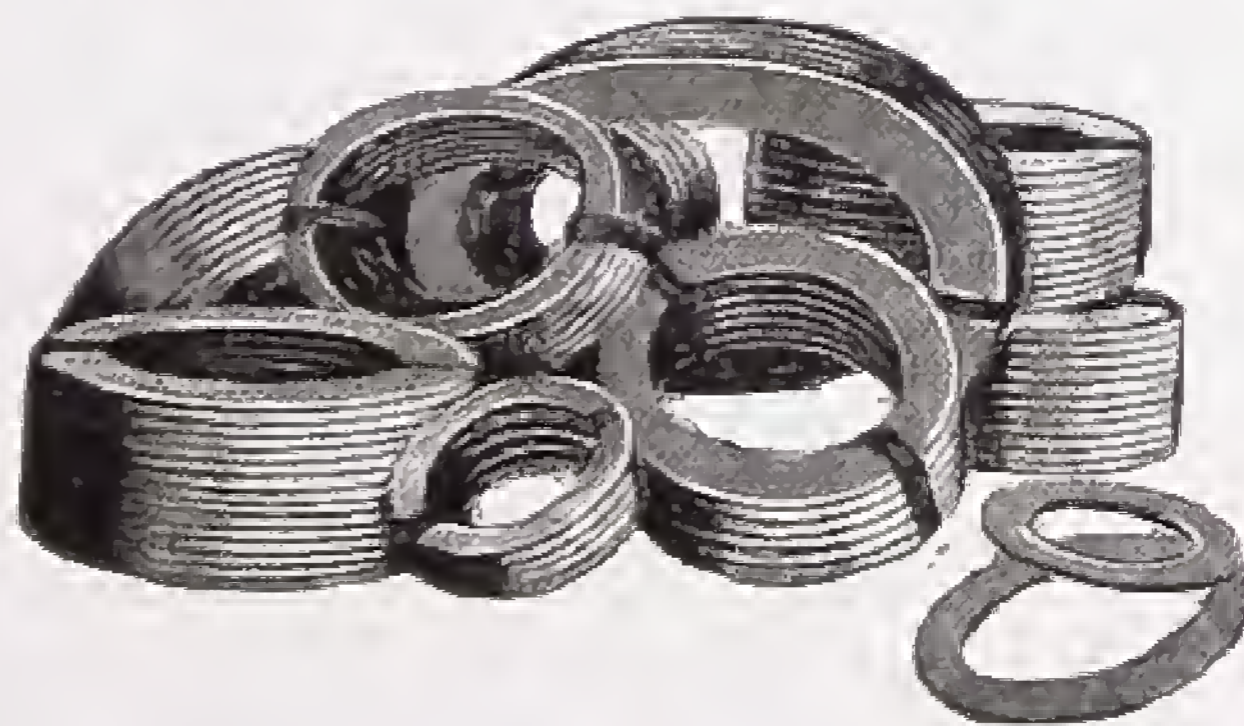

BAXENDALE & CO. LTD.

FLEXIBLE METALLIC TUBING AND FITTINGS

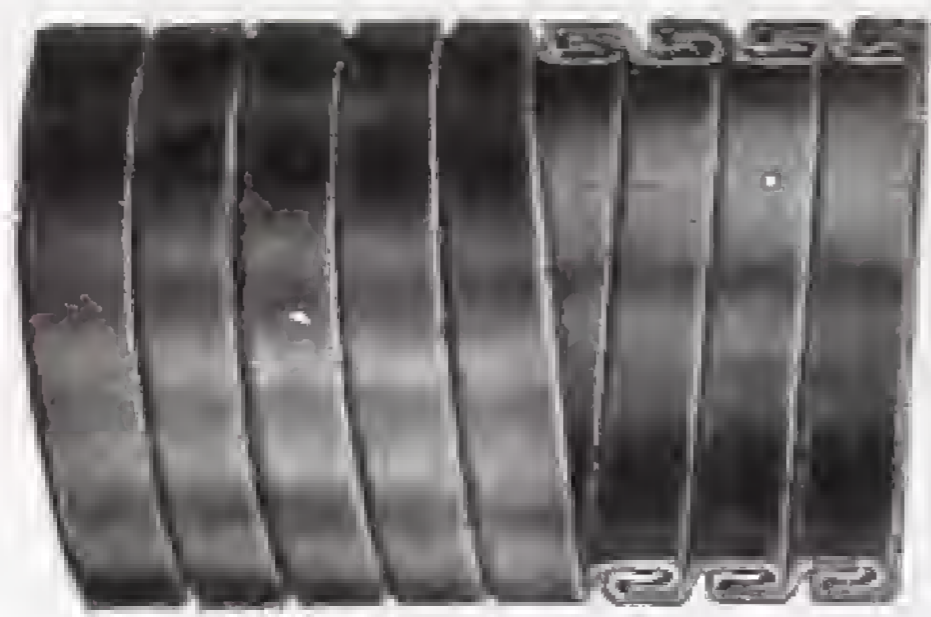

No. B 3498

Bronze interlocked flexible tube for steam.
Will stand a working pressure of 300 lbs. per \square ".

No. B 3500

Steel interlocked flexible tube.
Suitable for high-pressure suction or delivery of tar,
naphtha, petroleum and compressed air.

No. B 3501

Steel galvanized flexible metallic A.P.R.P. tube for
motor exhaust, hot air, etc.

GUN METAL CONNECTIONS for flexible Metallic Tubing

No. B 3503

Suitable for B 3498 bronze tube with iron pipe threads.

No. B 3504

Suitable for B 3500 steel tube with iron pipe threads.

NOTE—It is most important that suitable connections are used with flexible tubing, and we recommend customers to have these fitted at the works before delivery.

This work is done free of charge if tubing and fittings are supplied together.



No. B 2909



No. B 2910



No. B 2911

CAST-IRON FULLWAY SLUICE VALVES

Solid wedge. Inside screw. Standard Heavy Pattern.

Spindle of high tensile bronze with gunmetal renewable wedge nut. Renewable valve seating rings and wedge rings of gunmetal.

Every Valve is tested to 350 lbs. hydraulic pressure per \square " and proved sound before dispatch.

B 2909—Standard heavy pattern, double socket ends supplied in sizes 2 in. to 12 in. inclusive.

B 2910—Standard heavy pattern hexagon nuts screwed female, supplied in sizes 1½ in. to 10 in. inclusive.

B 2911—Standard heavy pattern, flanged ends, supplied in sizes 1½ in. to 16 in. inclusive.

Working Water Pressures

Up to and including 7 in. size suitable for 150 lbs. per \square ".

8 in. size and upwards suitable for 185 lbs. per \square ".

All the above valves can be fitted with cast-iron hand wheel or cap at the same prices.

MILLER STREET · MANCHESTER

FIRE HYDRANTS, GROUND BOXES, Etc.

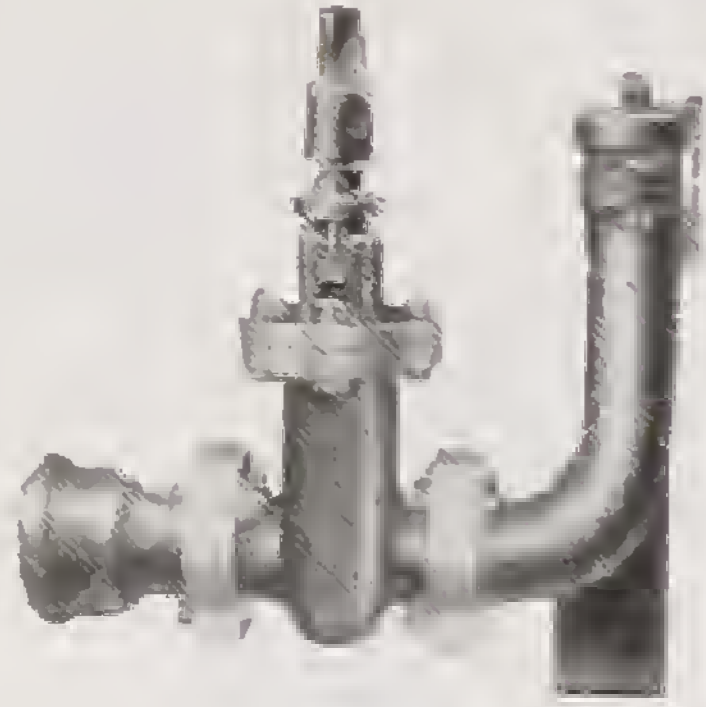

No. B 2923

**SLUICE VALVE
FIRE HYDRANT**

Comprising sluice valve with forged manganese bronze spindle. Socket or spigot can be bolted to inlet. The short sweep duck-foot bend can be fitted with frost valve, if required. Standard inlet sizes—2-in., 2½-in. and 3-in.



No. B 2918
**GROUND
BOX**

Cast-iron.
For Sluice
Valves.

Size Overall :
11¼-in. diam.
9½-in. deep.
with 3½-in. dia.
Clear Opening.

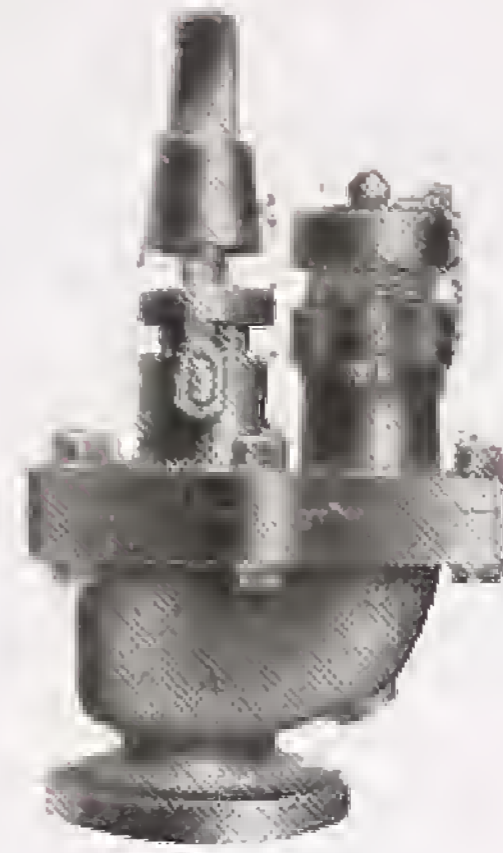

No. B 2924
**SPINDLE
HYDRANT**

With loose stopper and gunmetal outlet screwed. Inlet sizes—2½-in. and 3-in. Can be fitted with frost valve or frost plug as desired.

Both hydrants illustrated above are supplied with outlets screwed Old London Brigade Standard unless otherwise specified. Valves are fitted with forged manganese bronze spindle and gunmetal internal parts.



No. B 2915
**TURNCOCK
KEY**

30 in. long.
Finished Black
or Bright.



No. B 2922
POKER

20 in. long.
Finished Black
or Bright.



No. B 2921
HYDRANT LID KEY
Galvanized.



No. B 2919
GROUND BOX

Cast-iron.
For Ball Hydrants.
Size of Base :
12½-in. × 11½-in.
Clear Opening :
5¾-in. × 4¾-in.
Depth : 7-in.



No. B 2916
**SCOURING
KEY**

For Ball
Hydrants.

Special Quotations will be given for any type of Fire Hydrant or Ground Box on receipt of a specification.

FIRST AID FIRE APPLIANCES



No. G 6977

**SINGLE SWIVEL
VALVE HYDRANT.**
Bayonet or Round
Thread



No. G 6978

STAND PIPES
Swivel Head for
BALL or VALVE
HYDRANTS

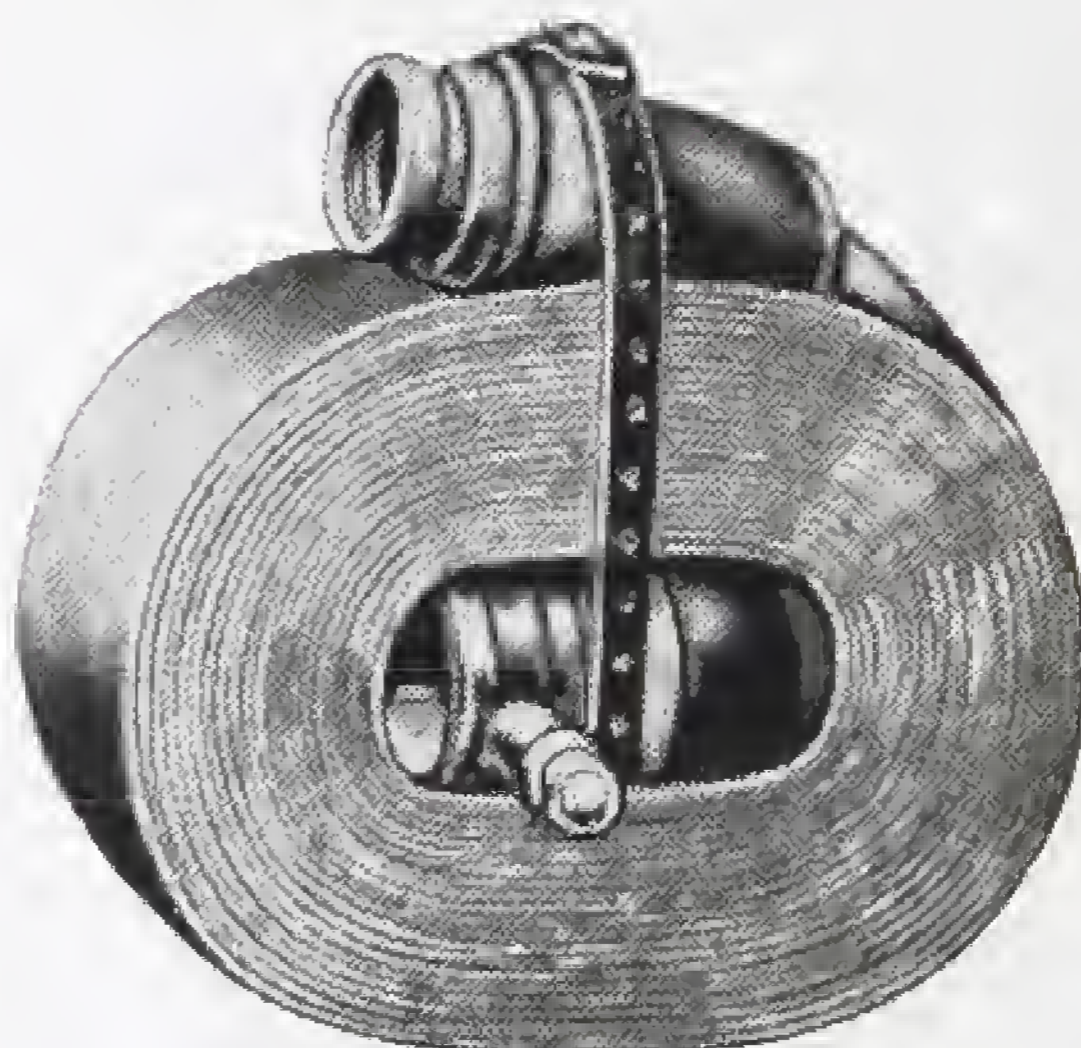

“BEANO” FIRE HOSE SEAMLESS WOVEN FROM PURE FLAX YARN
For Fire Brigade Use.

12-STRAND

Light weight pure flax Fire Hose, shrunk and burnettised as a preservative. Suitable for light work, washing down and flushing purposes.

18-STRAND

Made from selected flax yarn shrunk and burnettised, most suitable for use in mills, warehouses, etc. Guaranteed to withstand 400 lb. pressure per square inch.

24-STRAND

Extra heavy pure flax Fire Hose, 9-ply warps, specially recommended for Fire Brigade use. Guaranteed to withstand 500 lb. pressure per square inch. Genuine hand-woven, made solely from the finest long staple flax yarns, 24-strand weft 9-ply warps, shrunk and burnettised. The finest hose woven, as supplied to many leading Fire Brigades.

MEASUREMENT OF HOSE WHEN FLAT

Internal diam.	...	$\frac{1}{8}$	1	$1\frac{1}{4}$	$1\frac{1}{2}$	$1\frac{3}{4}$	2	$2\frac{1}{4}$	$2\frac{1}{2}$	$2\frac{3}{4}$	3	$3\frac{1}{4}$	$3\frac{1}{2}$	$3\frac{3}{4}$	4 in.
Flat width	...	$1\frac{1}{8}$	$1\frac{1}{2}$	$2\frac{1}{8}$	$2\frac{1}{2}$	3	$3\frac{3}{8}$	$3\frac{3}{4}$	$4\frac{1}{8}$	$4\frac{1}{2}$	$4\frac{5}{8}$	$5\frac{1}{4}$	$5\frac{5}{8}$	$6\frac{1}{8}$	$6\frac{1}{2}$ in.

FIRST AID FIRE APPLIANCES

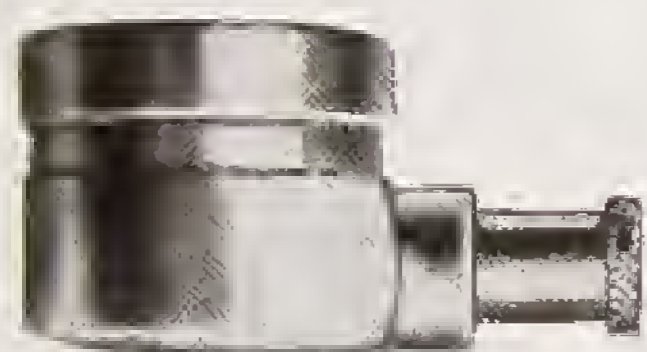

No. G 6995
**GUNMETAL
CONNECTOR**

screwed female, to
instantaneous female.



No. G 6996
BRANCH PIPE
18 in. long, to suit instantaneous hose couplings.

No. G 6997
BRANCH PIPE

18 in. long, screwed bottom.



No. G 6986
FIRE VALVE

(Obtuse Pattern)

With polished body and gunmetal
wheel.

No. G 6987

With painted body and cast-iron
wheel.

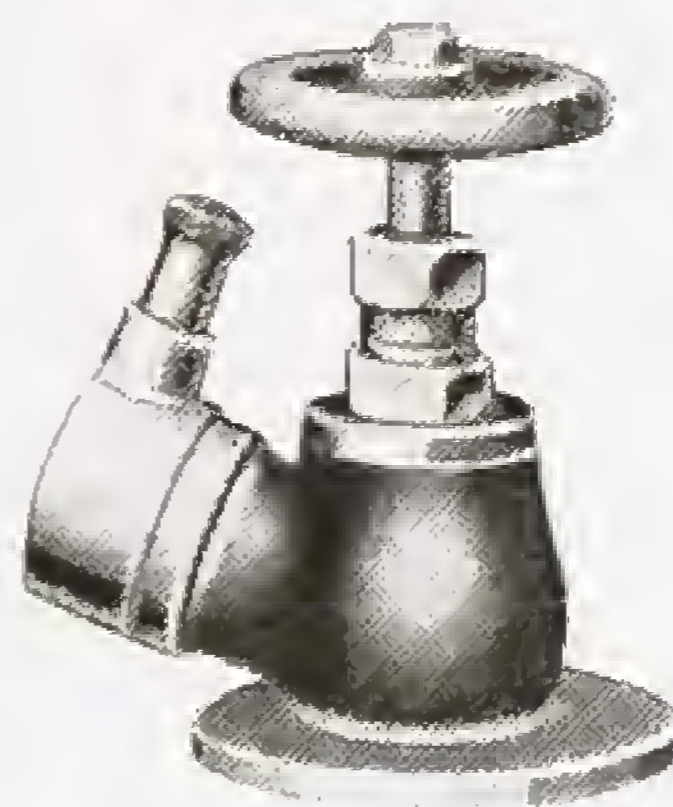

No. G 6992
FIRE VALVE
(Oblique Pattern.)

With polished body and gunmetal
wheel.

No. G 6993

With painted body and cast-iron
wheel.

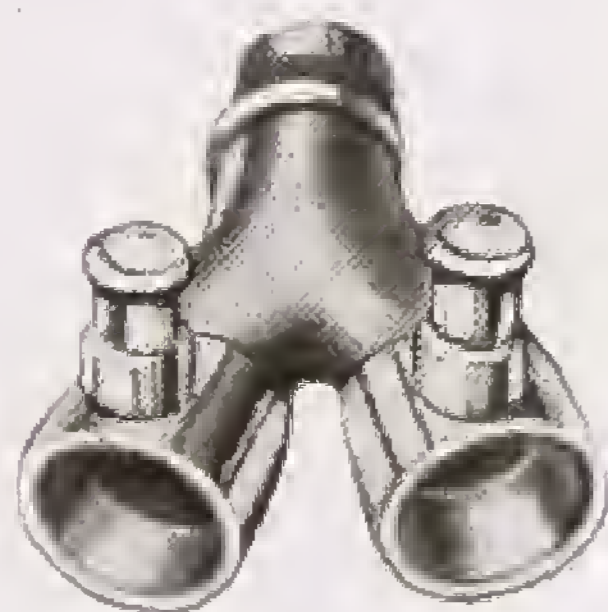

No. G 6994
BREECHING PIECE

Instantaneous dividing breaching
piece.

No. G 6983
**INSTANTANEOUS
COUPLING**

$2\frac{1}{2} \times 2\frac{1}{2}$ in. instantaneous.

$2\frac{1}{2} \times 2$ in. tails.

$2\frac{1}{2} \times 2\frac{3}{4}$ in. tails.

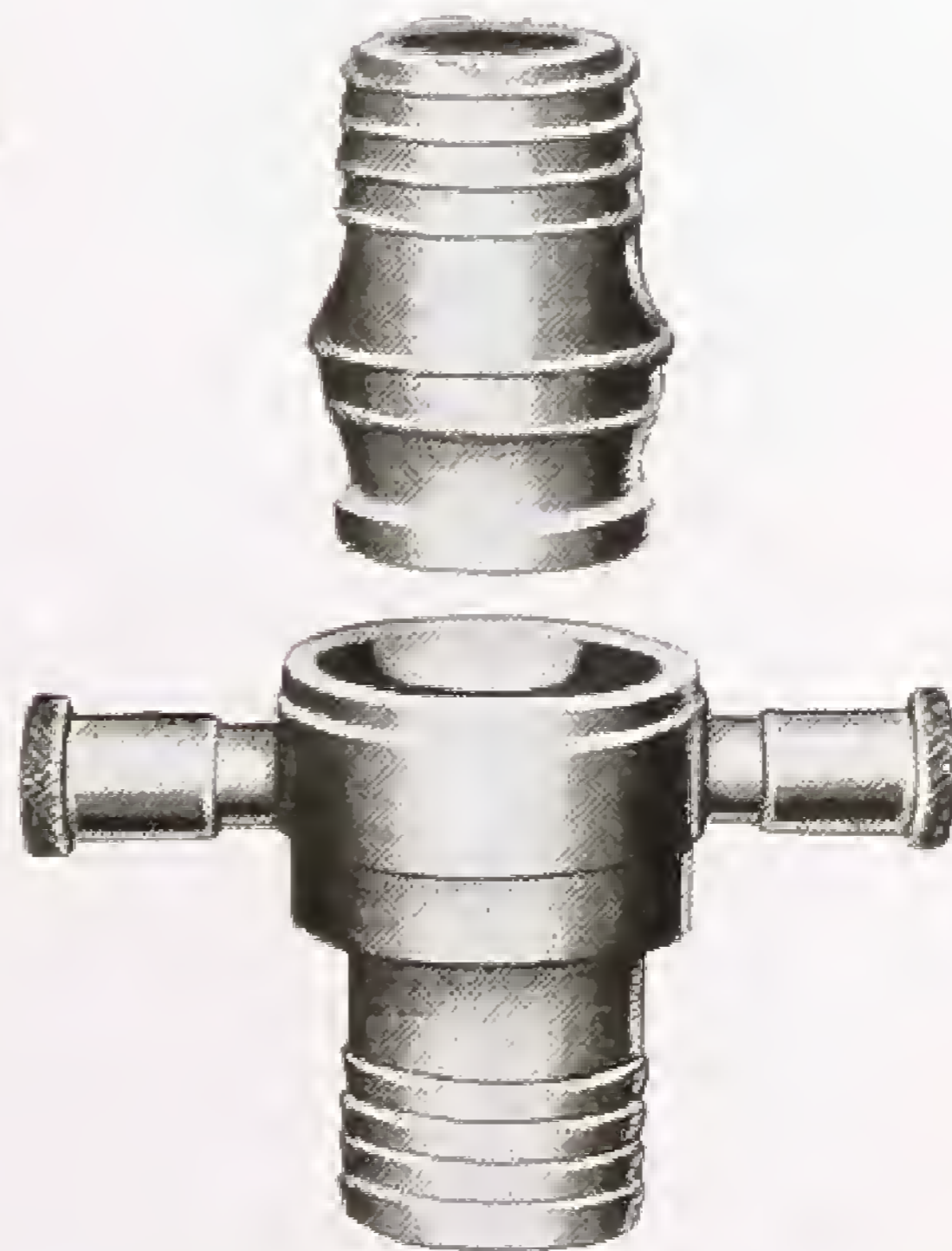

FIRE PROTECTION IS SELF PROTECTION

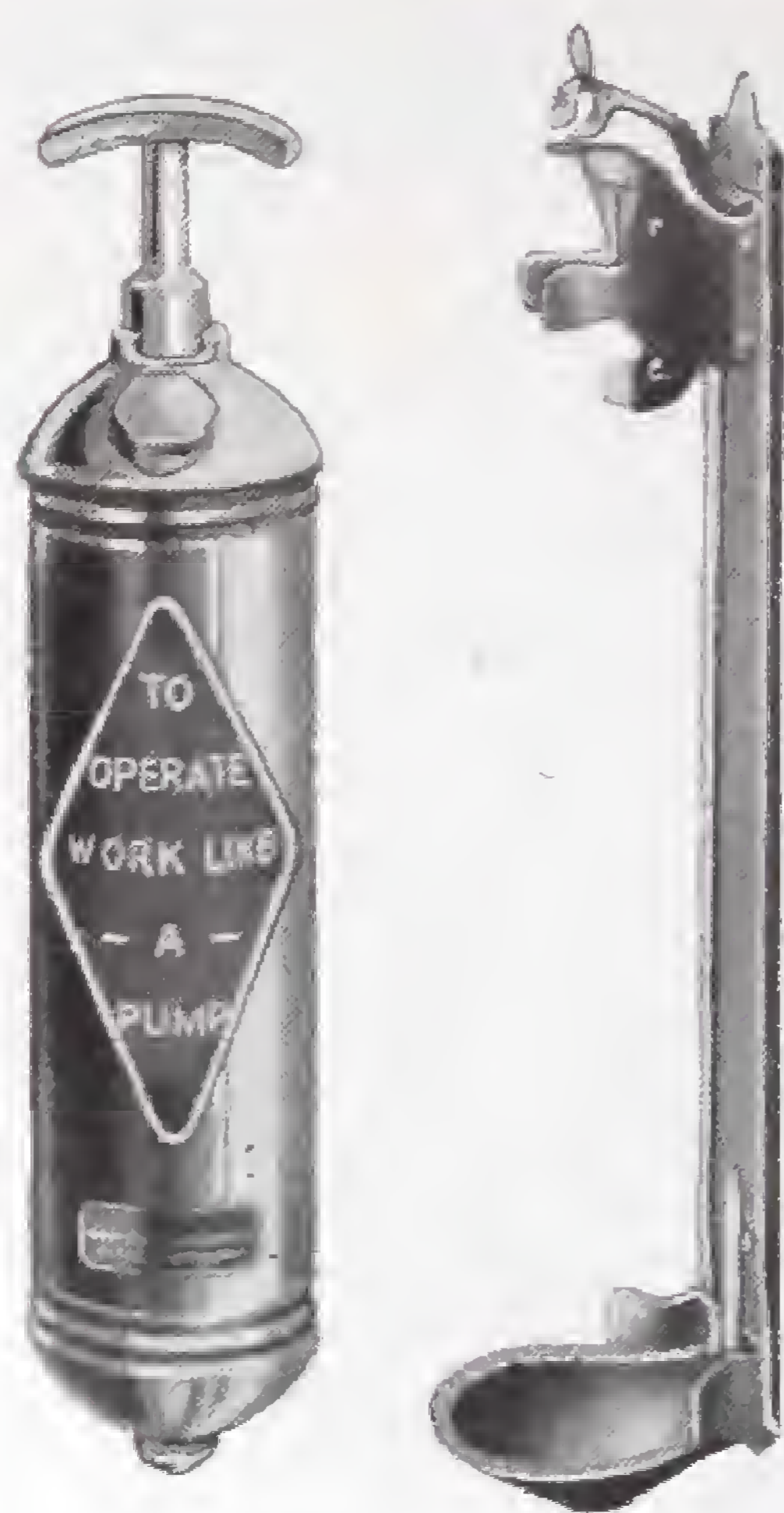

“BEANO” PUMP TYPE
Fire Extinguisher

For Motor Cars and Commercial
Vehicles.

Strongly Constructed. Standard Size.
The fluid is expelled by means of a
strong double-action Pump, which
throws a continuous stream a distance
of 20 feet.

“Beano” fluid will not damage the
most delicate fabric, neither will it
corrode nor freeze.

Size : 14 × 3 in.

Approximate weight when charged
6 lb.

Polished Brass or Chromium-Plated
including Steel Bracket.

Quart or Pint Capacity.

“BEANO” FOAM TYPE

For Fighting Oil and Liquid Fire
The simplicity and ease in operating
the “Beano” Foam Type Extinguisher,
is an outstanding feature. To
operate—Turn upside down—
immediately a thick and tenacious
Fire-Fighting Foam is produced,
capable of dealing with the most
dangerous and difficult type of fire,
such as Petrol, Oil, Tar, etc.

Two harmless dry powders dissolved
in water make the charging solutions.
The moment these solutions come in
contact they expand eight times their
own volume, at the same time im-
prisoning the carbonic acid gas which
is generated. It is due to this com-
bined action that the Foam acts on a
two-fold principle, it kills the flames
with the carbonic acid gas, and smothers
the fire with a thick fireproof covering.
2 gall. capacity, including charge.

Refills extra.



"BEANO" FIRST AID FIRE EXTINGUISHERS



**SODA ACID
TURNOVER TYPE**

2-gallon capacity
(including charge).
Refills extra.



**SODA ACID
CONICAL TYPE**

(including charge).
1 or 2-gallon capacity.
Refills extra.



SODA ACID TYPE

for use in **WORKS, MILLS, FACTORIES, etc.**

PRICES ON APPLICATION

These appliances are constructed to comply with the British Standard Institution Specification, they are also passed and approved by the Fire Officers' Committee for General Protection. They are manufactured in Great Britain from heavy gauge steel, lead coated inside and out, before and after manufacture—tested to 350 lb. pressure. Finished in Cellulose Fire Red, and have attractive transfers, giving full working instructions. The charges are made from the finest chemicals obtainable, and when brought into use produce one of the most powerful fire fighting jets ever obtained from chemical fire extinguishers, throwing a stream of fire-killing fluid a distance of 25 to 30 feet.

FIRST AID FIRE APPLIANCES

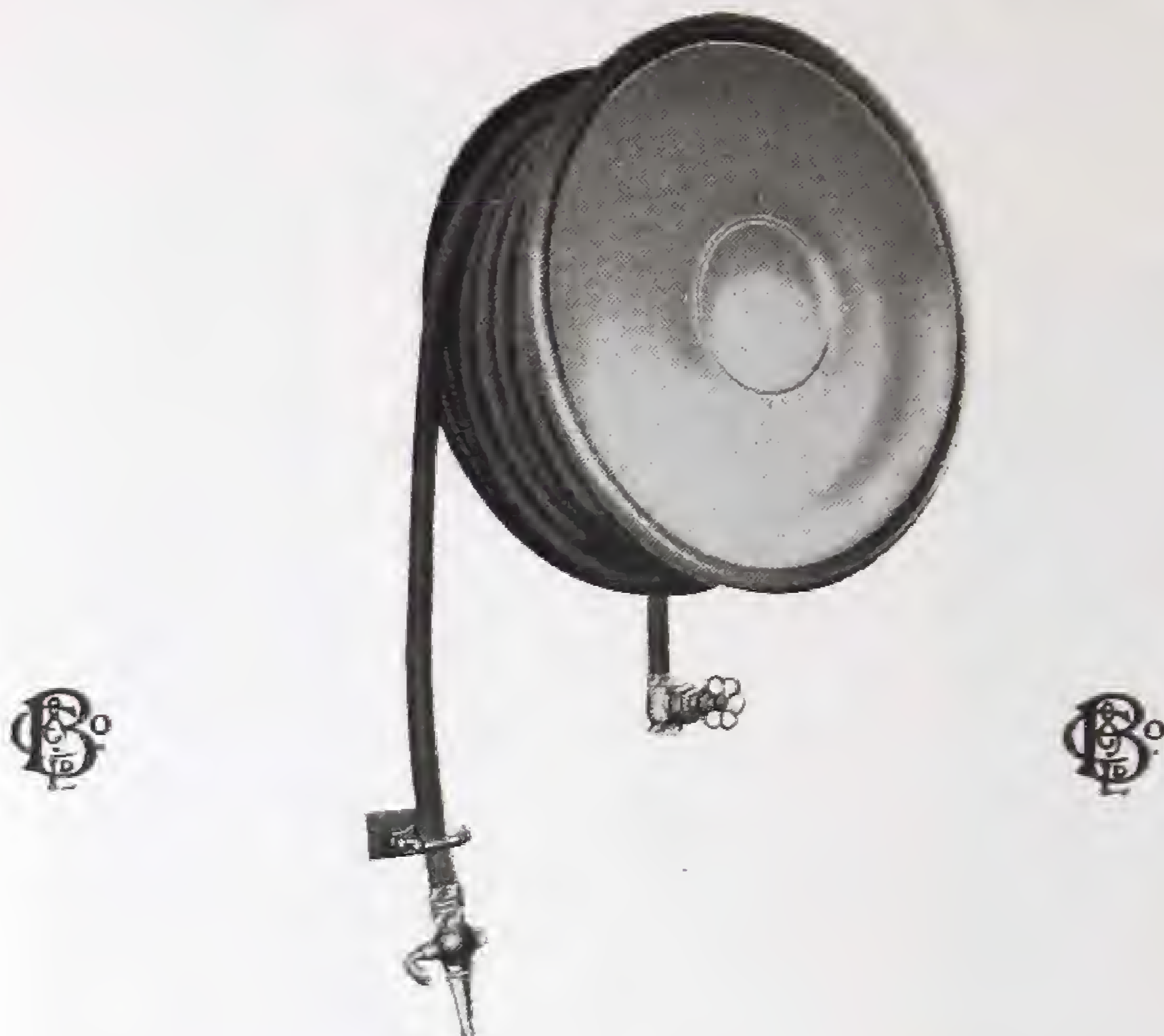

No, G 6999

FIRST AID FIRE HOSE REEL

Made in Various Sizes to hold any length of $\frac{3}{4}$ in. or 1 in. Bore Delivery Hose from 60 ft. to 120 ft.



FIRE BUCKET
BRACKETS
No. G 6963



No. G 6960. BUCKET

Well galvanized, then painted two coats (White) inside, and two coats (Red) outside, and lettered "FIRE" in 2-in. block letters.

12 in. diameter at top.

MALLEABLE IRON FITTINGS BEADED



RW 90
Elbow

RW 120
Elbow
45°

RW 221
Elbow
Side
Outlet

RW 92
Street
Elbow

RW 130
Tee

RW 223
Tee
Side
Outlet



RW 180
Cross

RW 60
Return
Bend
Open

RW 270
Socket
Straight

RW 246
Socket
Diminished

RW 260
Socket
Eccentric

RW 241
Bush



RW 96
Union
Elbow

RW 828
Bracket

RW 827
Bracket

RW 860
Clip

RW 340
Hex.
Union

No.	$\frac{1}{4}$	$\frac{3}{8}$	$\frac{1}{2}$	$\frac{3}{4}$	1	$1\frac{1}{4}$	$1\frac{1}{2}$	2	$2\frac{1}{2}$	3	In. Each
RW 60	1/1	1/5	1/6	2/5	3/6	5/-	7/-	11/-	17/6	23/6	
RW 90	6 $\frac{1}{2}$ d.	8 $\frac{1}{2}$ d.	9 $\frac{1}{2}$ d.	12 $\frac{1}{2}$ d.	1/8 $\frac{1}{2}$	2/7	3/6	5/-	9/-	14/-	..
RW 92	7 $\frac{1}{2}$ d.	9 $\frac{1}{2}$ d.	11d.	1/4	1/11	2/10	3/7	5/6	10/-	16/-	..
RW 96	2/1 $\frac{1}{4}$	2/7 $\frac{1}{4}$	3/-	4/-	5/2 $\frac{1}{2}$	7/4 $\frac{3}{4}$	10/-	14/-	25/-	40/-	..
RW 120	6 $\frac{1}{2}$ d.	8 $\frac{1}{2}$ d.	10d.	1/3	1/9	2/8	3/6	5/-	9/-	14/-	..
RW 130	8 $\frac{1}{2}$ d.	9 $\frac{1}{2}$ d.	1/-	1/5	2/-	2/10	4/-	5/6	10/-	16/-	..
RW 180	1/-	1/2 $\frac{1}{2}$	1/5	2/-	2/10	3/8	5/3	7/3	12/-	19/3	..
RW 221	1/-	1/3	1/5	2/3	2/11	4/5	6/-	8/-	—	—	..
RW 223	1/3	1/5	1/10	2/8	3/8	5/-	7/-	9/6	—	—	..
RW 246	5d.	5 $\frac{1}{2}$ d.	7d.	9d.	1/-	1/6	2/-	3/-	4/10	7/9	..
RW 241	4 $\frac{1}{2}$ d.	5d.	6d.	8d.	11d.	1/5	1/10	2/9	4/6	7/-	..
RW 260	—	7 $\frac{1}{2}$ d.	9 $\frac{1}{2}$ d.	1/-	1/5	1/10	2/5	3/3	5/3	8/6	..
RW 270	4 $\frac{1}{2}$ d.	5d.	6d.	8d.	10 $\frac{1}{2}$ d.	1/4	1/10	2/8	4/5	7/-	..
RW 340	2/1 $\frac{1}{4}$	2/4 $\frac{3}{4}$	2/10 $\frac{3}{4}$	3/7 $\frac{1}{4}$	4/4 $\frac{3}{4}$	5/9 $\frac{1}{2}$	7/9 $\frac{1}{2}$	11/-	19/6	31/6	..
RW 827	9d.	9 $\frac{1}{2}$ d.	10d.	1/1	1/6	2/-	2/7 $\frac{1}{2}$	3/9	6/-	6/9	..
RW 828	6 $\frac{1}{2}$ d.	7d.	8d.	10d.	1/2	1/7	2/-	2/9	4/-	5/6	..
RW 860	2 $\frac{1}{2}$ d.	3 $\frac{1}{2}$ d.	4d.	4 $\frac{1}{2}$ d.	4 $\frac{1}{2}$ d.	5d.	5 $\frac{1}{2}$ d.	7 $\frac{1}{2}$ d.	—	—	..

Prices subject to current plusages.

PRICES AND ILLUSTRATIONS OF MALLEABLE
IRON RAILING FITTINGS SENT ON APPLICATION.

BAXENDALE & CO. LTD.

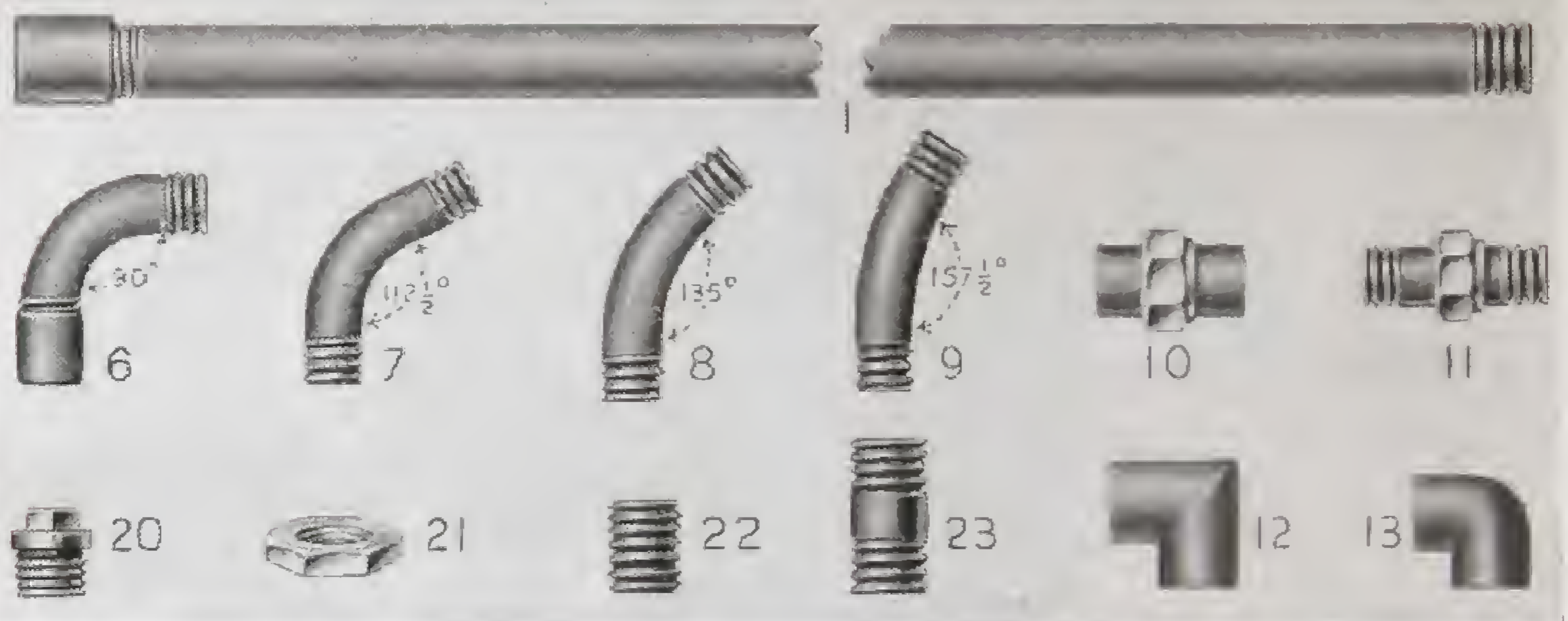

STANDARD LIST OF WROUGHT
For GAS, STEAM
Issued 1st January, 1921

TUBES						
No.	Nominal Internal Diameter in Inches		$\frac{1}{8}$ & $\frac{1}{4}$	$\frac{3}{8}$	$\frac{1}{2}$	$\frac{3}{4}$
1	Tubes, 2-ft. long and over	per ft.	4d.	4½d.	5½d.	6½d.
2	Pieces, 12-in. to 23½-in. long	each	10d.	11d.	1/1	1/5
3	" 4-in. to 11½-in. long	"	7d.	8d.	9d.	11d.
4	Long Screws, 12-in. to 23½ in. long	"	11d.	1/-	1/3	1/7
5	" 3-in. to 11½-in. long	"	8d.	9d.	10d.	1/1
23	Barrel Nipples	"	5d.	5d.	6d.	7d.
6	Bends	"	8d.	9d.	11d.	1/2
7, 8 & 9	Springs, not socketed	"	5d.	6d.	7d.	9d.
FITTINGS						
11	Socket or Pipe Union	each	2/-	2/6	3/-	4/-
12	Elbows, Square	"	10d.	11d.	1/1	1/3
13	" Round	"	11d.	1/-	1/2	1/5
14	Tees	"	1/-	1/1	1/3	1/7
15	Crosses	"	2/2	2/4	2/9	3/3
16	Sockets, Plain	"	3d.	3d.	4d.	5d.
17	" Diminished	"	4d.	5d.	6d.	7d.
18	Flanges	"	9d.	10d.	1/-	1/2
19	Caps	"	3½d.	3½d.	5d.	6d.
20	Plugs	"	3d.	3d.	4d.	5d.
21	Backnuts	"	2d.	2d.	3d.	3½d.
22	Nipples	"	2d.	2d.	3d.	3½d.
24	Union Bends	"	2/6	3/-	3/9	5/-
25	Main Cocks	"	1/6	1/9	2/3	2/10
26	" with Brass Plugs	"	—	3/4	4/-	5/4
27	Round Way Cocks	"	—	2/7½	3/-	4/1½
28	" with Brass Plugs	"	—	7/10½	9/-	12/4½
29	Cock Spanners, Wrought	"	—	1/1½	1/3	1/7½
30	" Malleable Cast	"	—	9d.	1/-	1/3
31	Siphon Boxes, 1 quart	"	—	—	22/9	23/-
32	" 2 quarts	"	—	—	—	27/-
33	" 3 quarts	"	—	—	—	32/-
34	" 4 quarts	"	—	—	—	38/-

Subject to current plusages.

MILLER STREET · MANCHESTER

BAXENDALE & CO. LTD.

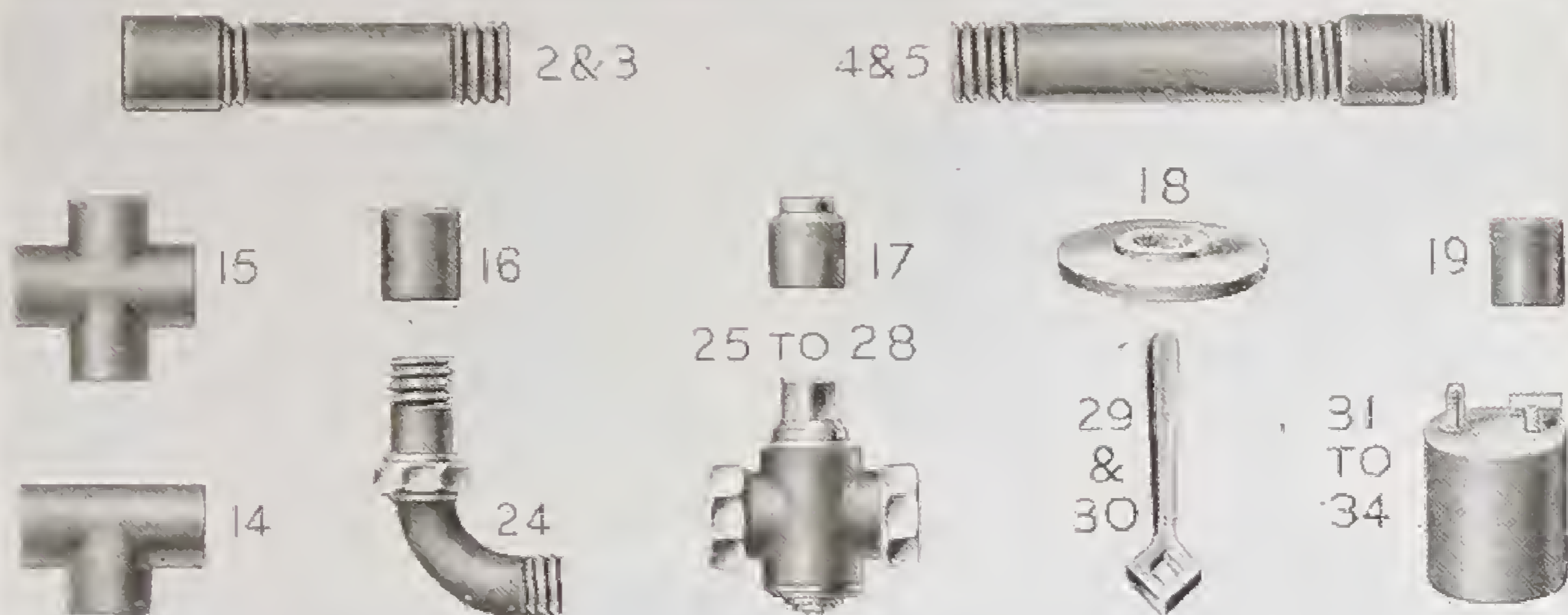

IRON TUBES AND FITTINGS AND WATER cancelling all other Lists.

1	1¼	1½	2	2½	3	3½	4	5	6
9½d.	1/1	1/4½	1/10	2/10	3/3	4/-	4/5	6/-	7/6
1/11	2/8	3/4	4/9	8/-	10/6	13/6	15/6	24/-	32/6
1/3	1/8	2/2	3/-	5/3	6/9	9/3	10/9	18/-	25/3
2/2	2/10	3/9	5/3	9/-	12/-	15/6	17/-	26/6	35/6
1/5	1/11	2/6	3/6	6/6	8/6	11/6	13/-	20/-	28/-
9d.	1/-	1/4	1/9	3/-	4/-	6/-	7/-	12/6	20/-
1/7½	2/7½	3/2	5/2	12/-	18/-	25/-	32/6	105/-	150/-
1/1½	1/11½	2/3½	3/11	9/6	14/6	20/-	26/6	93/-	132/-
5/6	6/9	8/-	10/-	17/6	22/6	27/6	35/-	66/-	105/-
1/6	2/2	2/7	4/3	9/6	14/-	22/-	28/-	95/-	150/-
1/8	2/4	2/10	4/8	10/6	16/-	24/-	30/-	95/-	150/-
1/10	2/6	3/1	5/1	11/6	18/-	26/-	32/-	98/-	155/-
4/1	5/6	6/7	10/6	22/-	40/-	56/-	66/8	220/-	350/-
6d.	8d.	10½d.	1/3	2/6	3/6	5/-	6/-	12/-	18/-
9d.	1/-	1/4	2/-	5/-	7/-	9/-	11/-	35/-	55/-
1/4	1/9	2/-	2/9	5/-	8/6	10/-	11/6	18/-	27/-
8d.	1/-	1/3	2/-	4/4	6/-	9/9	10/6	30/-	45/-
6d.	8d.	10d.	1/3	2/6	4/9	7/-	10/-	30/-	48/-
5d.	6d.	8d.	1/1	2/3	3/6	4/6	5/6	18/-	26/-
4d.	6d.	8d.	1/-	2/3	3/6	4/6	5/6	18/-	26/-
6/3	8/6	10/-	13/6	27/-	37/-	49/-	58/-	100/-	160/-
4/2	5/4	7/-	11/6	17/6	26/-	40/-	47/9	125/-	165/-
7/6	10/-	13/-	21/-	40/-	50/-	75/-	100/-	225/-	325/-
5/7½	7/6	9/9	16/6	45/-	56/3	90/-	120/-	—	—
16/10½	22/6	29/3	49/6	135/-	168/9	270/-	360/-	—	—
2/-	2/4½	2/7½	3/3	4/6	6/9	9/-	10/6	14/3	18/-
1/6	1/9	2/3	3/-	4/6	6/9	9/-	10/6	14/3	18/-
23/4	24/-	24/6	26/3	—	—	—	—	—	—
27/4	28/-	28/6	30/3	35/6	42/6	—	—	—	—
32/4	33/-	33/6	35/3	40/6	47/6	55/6	61/6	—	—
38/4	39/-	39/6	41/3	46/6	53/6	61/6	67/6	—	—

Subject to current plusages.

BAXENDALE & CO. LTD.

GUN METAL PIPE FITTINGS



No. B 3230



No. B 3234



No. B 3238



No. B 3236



No. B 3240



No. B 3241



No. B 3242



No. B 3256



No. B 3257



No. B 3259

Screwed iron threads.
All fittings hydraulically tested.
The various sizes supplied are denoted by *

Sizes in inches	$\frac{1}{4}$	$\frac{3}{8}$	$\frac{1}{2}$	$\frac{3}{4}$	1	1 $\frac{1}{2}$	2	2 $\frac{1}{2}$	3
B 3230. Female Hexagon Union ...	*	*	*	*	*	*	*	*	*
B 3234. Female Union ...			*	*	*	*	*	*	*
B 3236. Female iron to lead Union ...			*	*	*	*	*	—	—
B 3238. Male and female Union ...			*	*	*	*	*	—	—
B 3240. Socket ...			*	*	*	*	*	*	*
B 3263. †Reducing Socket ... (as B 3240 with reduced end)			—	*	*	*	*	*	*
B 3241. Tee ...			*	*	*	*	*	*	*
B 3242. Elbow ...			*	*	*	*	*	*	*
B 3256. Bend 90° ...			*	*	*	*	*	*	*
B 3257. Return Bend ...			*	*	*	*	*	*	*
B 3259. Cross ...			*	*	*	*	*	*	*

† Details given for B 3263 are for size of largest end.

MILLER STREET · MANCHESTER

BAXENDALE & CO. LTD.

GUN METAL PIPE FITTINGS



No. B 3246



No. B 3247



No. B 3248

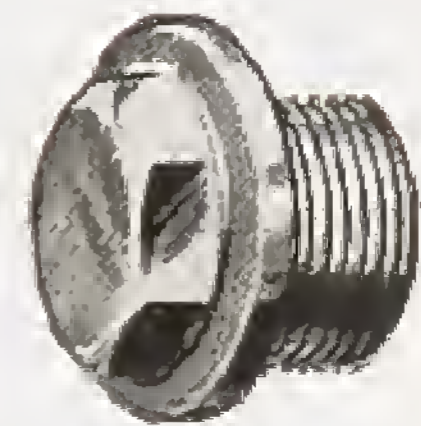

No. B 3249



No. B 3250

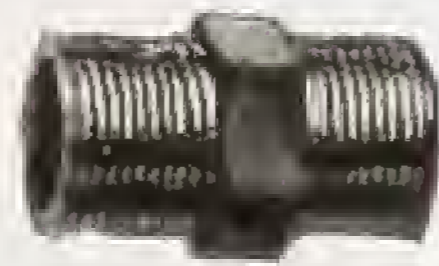

No. B 3254

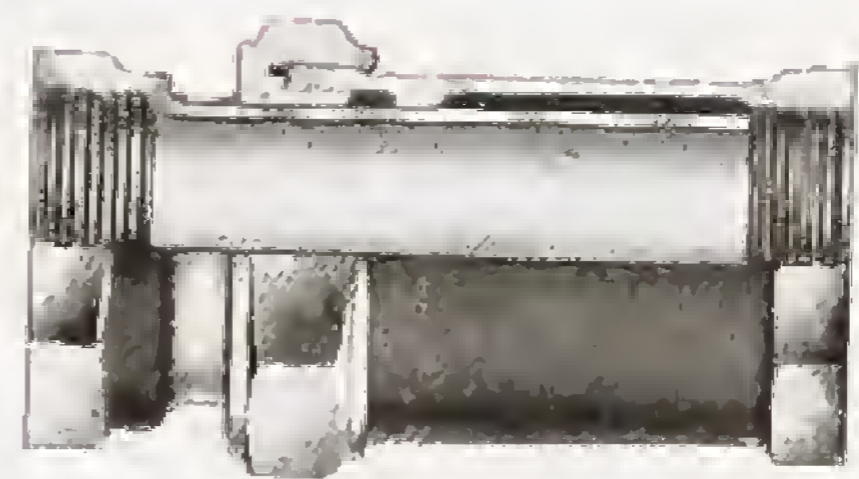

No. B 3239



No. B 3251



No. B 3252



No. B 3253

Screwed iron threads.

The various sizes supplied are denoted by *

Sizes in inches		$\frac{3}{8} \times \frac{1}{2}$	$\frac{1}{2} \times \frac{3}{4}$	$\frac{3}{4} \times 1$	$1 \times 1\frac{1}{4}$	$1\frac{1}{4} \times 1\frac{1}{2}$	$1\frac{1}{2} \times 2$	$2 \times 2\frac{1}{2}$	$2\frac{1}{2} \times 3$
B 3246.	Diminisher	*	*	*	*	*	*	*	*
Sizes in inches		$\frac{1}{2}$	$\frac{3}{4}$	1	$1\frac{1}{4}$	$1\frac{1}{2}$	2	$2\frac{1}{2}$	3
B 3247.	Nipple	*	*	*	*	*	*	*	*
B 3248.	Blank Cap	*	*	*	*	*	*	*	*
B 3249.	Plug	*	*	*	*	*	*	*	*
B 3250.	Back Nut	*	*	*	*	*	*	*	*
B 3254.	Hexagon Nipple	*	*	*	*	*	*	*	*
B 3239.	Expansion Joint	*	*	*	*	*	*	*	*
Sizes in inches		$\frac{1}{4}$	$\frac{3}{8}$	$\frac{1}{2}$	$\frac{3}{4}$	1	$1\frac{1}{4}$	$1\frac{1}{2}$	2
B 3251.	Single Swivel	*	*	*	*	*	*	*	*
B 3252.	Double Swivel	*	*	*	*	*	*	*	*
B 3253.	Universal Swivel	*	*	*	*	*	*	*	*

LIVERPOOL · EDINBURGH · DUBLIN

BAXENDALE & CO. LTD.

GUN METAL PIPE FITTINGS



No. B 3300

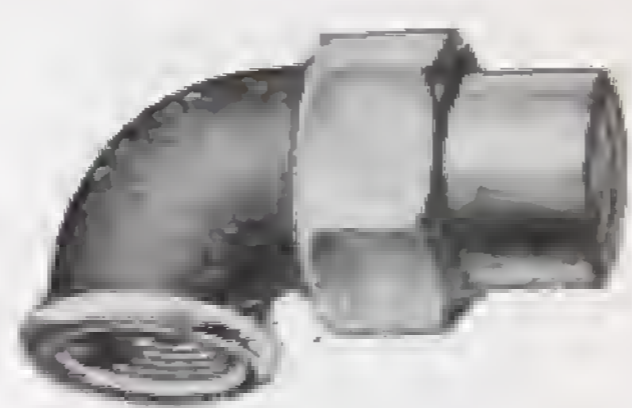

No. B 3306



No. B 3304



No. B 3302



No. B 3309

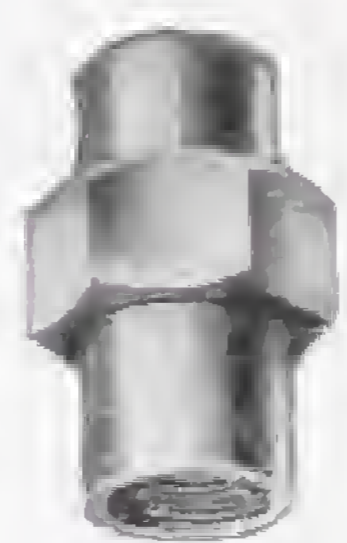

No. B 3310

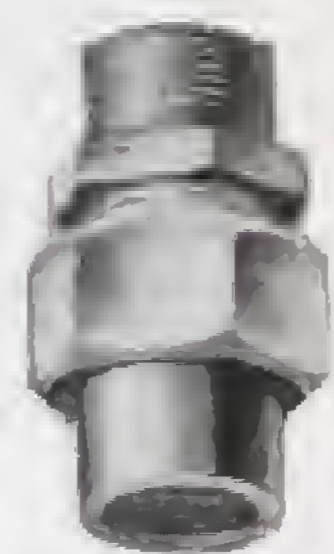

No. B 3317



No. B 3325



No. B 3312



No. B 3297

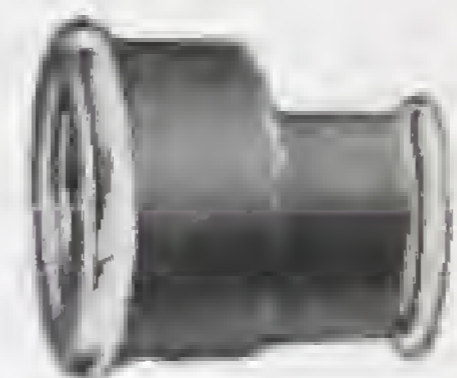

No. B 3298

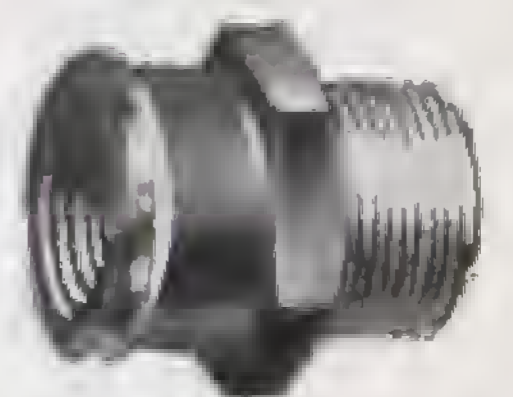

No. B 3299

For copper tubes ; screwed B.S. Table 1 or 16 threads for 14 S.W.G.

The various sizes supplied are denoted by *

Sizes in inches		1/2	3/4	1	1 1/4	1 1/2	2	2 1/2	3
B 3300.	Elbow	*	*	*	*	*	*	*	*
B 3306.	Elbow Union	*	*	*	*	*	*	*	*
B 3304.	Tee	*	*	*	*	*	*	*	*
B 3302.	Tee Union	*	*	*	*	*	*	*	*
B 3309.	Union, female copper to lead	*	*	*	*	*	*	—	—
B 3310.	Union, female	*	*	*	*	*	*	*	*
B 3317.	Union, male iron to female copper	*	*	*	*	*	*	*	*
B 3325.	Lug Elbow, iron to copper	*	*	*	—	—	—	—	—
B 3312.	Socket	*	*	*	*	*	*	*	*
B 3299.	Adaprer. Male iron to copper	*	*	*	*	*	*	*	*

Sizes in inches		3/4 x 1/2		1 x 3/4		1 1/4 x 1 1/2		2 x 1 1/2		2 1/2 x 2		3 x 2 1/2	
B 3297.	Reducing Socket (Concentric)	—	*	*	*	*	*	*	*	*	*	*	*
B 3298.	Reducing Socket (Eccentric)	—	*	*	*	*	*	*	*	*	*	*	*

MILLER STREET · MANCHESTER

BAXENDALE & CO. LTD.

GUN METAL PIPE FITTINGS



No. B 3301



No. B 3303



No. B 3305



No. B 3311



No. B 3313

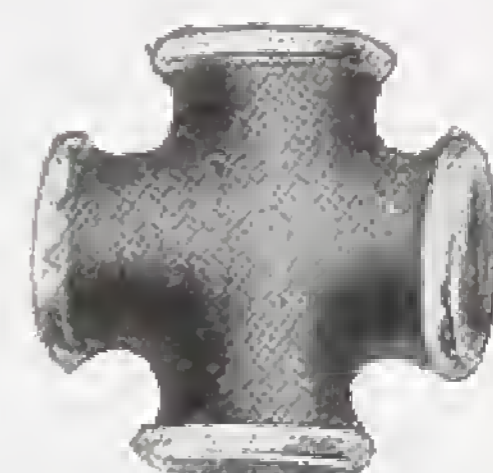

No. B 3315



No. B 3314



No. B 3316



No. B 3318



No. B 3320

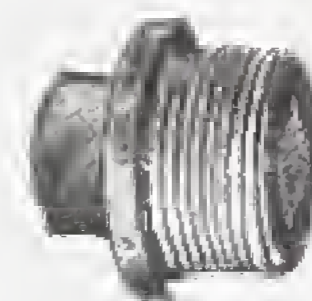

No. B 3321

For copper tubes; screwed B.S. Table 1 or 16 threads for 14 S.W.G.

The various sizes supplied are denoted by *

Sizes in inches		$\frac{1}{2}$	$\frac{3}{4}$	1	$1\frac{1}{4}$	$1\frac{1}{2}$	2	$2\frac{1}{2}$	3
B 3301.	Sweep Tee, 90° branch ...	*	*	*	*	*	*	*	*
B 3303.	Tee, 45° branch ...	*	*	*	*	*	*	*	*
B 3305.	Divided Tee ...	*	*	*	*	*	*	*	*
B 3311.	Bend, 90° ...	*	*	*	*	*	*	*	*
B 3313.	Return Bend ...	*	*	*	*	*	*	*	*
B 3315.	Cross ...	*	*	*	*	*	*	*	*
B 3314.	Backnut ...	*	*	*	*	*	*	*	*

Sizes in inches		$\frac{3}{8} \times \frac{1}{2}$	$\frac{1}{2} \times \frac{3}{4}$	$\frac{3}{4} \times 1$	$1 \times 1\frac{1}{4}$	$1\frac{1}{4} \times 1\frac{1}{2}$	$1\frac{1}{2} \times 2$	$2 \times 2\frac{1}{2}$	$2\frac{1}{2} \times 3$
B 3316.	Diminisher ...	*	*	*	*	*	*	*	*

Sizes in inches		$\frac{1}{2}$	$\frac{3}{4}$	1	$1\frac{1}{4}$	$1\frac{1}{2}$	2	$2\frac{1}{2}$	3
B 3318.	Nipple ...	*	*	*	*	*	*	*	*
B 3320.	Cap ...	*	*	*	*	*	*	*	*
B 3321.	Plug ...	*	*	*	*	*	*	*	*

Additional Fittings, not illustrated

B 3319.	Fullway Valve ...	*	*	*	*	*	*	—	—
B 3323.	B.S. 1010 Stop Cock ...	*	*	*	*	*	*	—	—

LANCASTER · LEEDS · BLACKPOOL

PIPE FITTINGS

TINNED STEEL PIPE CLIPS



No. B 2578

Double Corrugated Pattern which gives increased strength and is a safeguard against damage to lead pipes.

Suitable for iron pipe of all sizes $\frac{1}{4}$ in. to 2 in. Also suitable for all poundages of lead pipe sizes $\frac{3}{8}$ in. to 2 in.

Copper clips similar to the above supplied for B.S.S. 659-55 copper tube all sizes $\frac{1}{2}$ in. to 2 in.

PIPE HOOKS

No. B 2613

Machine forged, self colour. Practically unbreakable and with extra large, strong shoulder for driving in.

No. B 2614

As above, galvanized.

For lead or iron pipe, all sizes $\frac{1}{4}$ in. to $1\frac{1}{4}$ in.



PIPE CLIPS



No. B 2600



No. B 2602/4



No. B 2606/8

Suitable for B.S.S.659-55 Copper Tube all sizes $\frac{1}{2}$ in. to 2 in.

No. B 2600. Stamped brass hinged pipe clip with bolts.

No. B 2602. Polished brass schoolboard pattern built-in clip.

No. B 2604. Black japanned schoolboard pattern built-in clip.

No. B 2606. Polished brass schoolboard pattern screw-on clip.

No. B 2608. Black japanned schoolboard pattern screw-on clip.

PIPE CLIPS



No. B 2609



No. B 2610



No. B 2611



No. B 2612

Suitable for B.S.S.659-55 Copper Tube all sizes $\frac{1}{2}$ in. to 2 in.

No. B 2609. Stamped copper double spacing clip.

No. B 2610. Stamped copper single spacing clip.

No. B 2611. Stamped copper rigid one-piece spacing clip.

No. B 2612. Polished brass pipe hanger with tapped shank.

BRASS GAS FITTINGS



MAIN COCK

For Iron. Rough.

G 250. O.T.P. F. Ends
 $\frac{1}{4}$, $\frac{3}{8}$, $\frac{1}{2}$, $\frac{3}{4}$, 1 in.

G 251. Sq. Head F. Ends
 $\frac{1}{4}$, $\frac{3}{8}$, $\frac{1}{2}$, $\frac{3}{4}$, 1, $1\frac{1}{4}$ in.

G 249. O.T.P. M. & F. Ends.
 $\frac{1}{4}$, $\frac{3}{8}$, $\frac{1}{2}$, $\frac{3}{4}$, 1 in.

G 248. Sq. Head. M. & F.
 $\frac{1}{4}$, $\frac{3}{8}$, $\frac{1}{2}$, $\frac{3}{4}$, 1, $1\frac{1}{4}$ in.



MAIN COCK AND UNION

No. G 247

For Iron and Lead.

G 247. O.T.P.
 $\frac{1}{4}$, $\frac{3}{8}$, $\frac{1}{2}$, $\frac{3}{4}$, 1 in.

G 246. Sq. Head
 $\frac{1}{4}$, $\frac{3}{8}$, $\frac{1}{2}$, $\frac{3}{4}$, 1, $1\frac{1}{4}$ in.



STOP COCK AND UNION

No. G 274A Rough

No. G 274 Polished

For Iron.
 Screwed Female Ends.

$\frac{1}{4}$, $\frac{3}{8}$, $\frac{1}{2}$, $\frac{3}{4}$ in.



No. G 193

STOP COCK

Bright.
 For Iron.

$\frac{1}{8}$, $\frac{1}{4} \times \frac{1}{8}$, $\frac{1}{4}$, $\frac{3}{8} \times \frac{1}{8}$,
 $\frac{3}{8} \times \frac{1}{4}$, $\frac{3}{8}$, $\frac{1}{2} \times \frac{1}{4}$,
 $\frac{1}{2} \times \frac{3}{8}$, $\frac{1}{2}$ in.



No. G 197

STOP COCK and UNION

Tighted. Bright.
 For Brass.

$\frac{3}{8}$, $\frac{1}{2} \times \frac{3}{8}$, $\frac{1}{2}$ in.



No. G 198

NOSEPIECE COCK

Bright.
 For Iron.

$\frac{1}{8}$, $\frac{1}{4} \times \frac{1}{8}$, $\frac{1}{4}$, $\frac{3}{8}$,
 $\frac{1}{2}$ in.



No. G 107

CEILING PLATES

For Iron.

G 106. Male. For Iron

G 107. Female. For Iron

$\frac{1}{8}$, $\frac{1}{4}$, $\frac{3}{8}$, $\frac{1}{2}$, $\frac{3}{4}$, 1 in.



No. G 171
SINGLE SWIVEL

Strong.
 Rough.
 For Iron.



No. G 175
DOUBLE SWIVEL

Strong.
 Rough.
 For Iron.



No. G 179
UNIVERSAL SWIVEL
 For Iron.

Sizes : $\frac{1}{8}$, $\frac{1}{4} \times \frac{1}{8}$, $\frac{1}{4}$, $\frac{3}{8} \times \frac{1}{4}$, $\frac{3}{8}$, $\frac{1}{2} \times \frac{1}{4}$, $\frac{1}{2} \times \frac{3}{8}$, $\frac{1}{2}$, $\frac{3}{4} \times \frac{1}{2}$, $\frac{3}{4}$ in.

BRASS GAS FITTINGS



No. G 211
AIR BURNER
3/8 in. Brass.

Length 3 1/4 4 1/4 in.



No. G 233
ATMOSPHERIC
BULB AND NIPPLE

Bright. For Iron.

- 1/8 in. M x 1/4 in. F
- 1/4 in. M x 1/4 in. F
- 1/4 in. M x 1/2 in. F
- 1/4 in. M x 3/4 in. F
- 1/4 in. M x 1 in. F
- 1/4 in. M x 1 1/4 in. F
- 1/4 in. M x 1 1/2 in. F
- 1/4 in. M x 1 3/4 in. F
- 1/4 in. M x 2 in. F
- 1/4 in. M x 2 1/4 in. F
- 1/4 in. M x 2 1/2 in. F
- 1/4 in. M x 2 3/4 in. F
- 1/4 in. M x 3 in. F
- 1/4 in. M x 3 1/4 in. F
- 1/4 in. M x 3 1/2 in. F
- 1/4 in. M x 3 3/4 in. F
- 1/4 in. M x 4 in. F



No. G 212
AIR BURNER

3/8 in. Brass.

Diam. 2, 2 1/2, 2 3/4, 3 in.

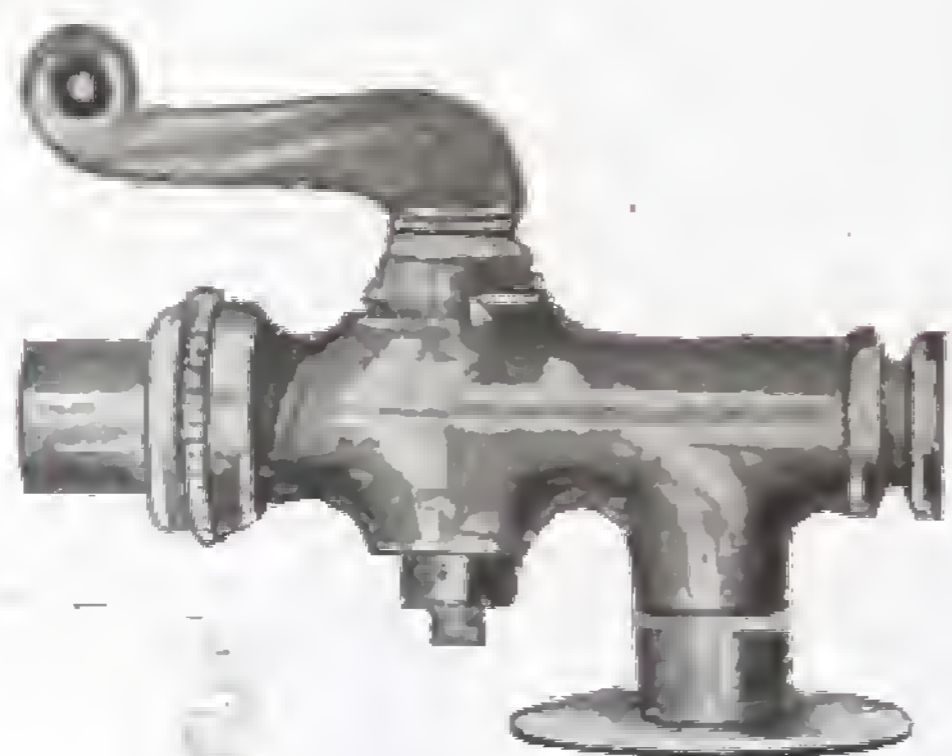

No. G 279
POLISHED GAS FIRE COCK
With Union. For Brass.
1/2 in.



No. G 276
THE SAFETY GAS FIRE TAP

Flange Type with stem cock for 1/4 in.



No. G 1113
FLOOR TAP
1/2 in. Brass.
Polished Brass Finish

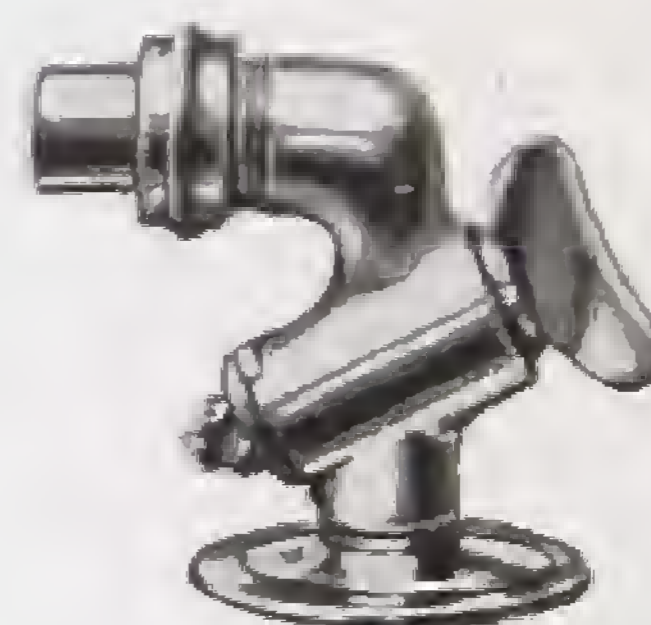

No. G 1112
FLOOR TAP
1/2 in. Brass.
Polished Brass Finish.

Flat Flame Gas Geyser Burners Sizes 00. No. 2. No. 3
supplied to order.

BRASS GAS FITTINGS

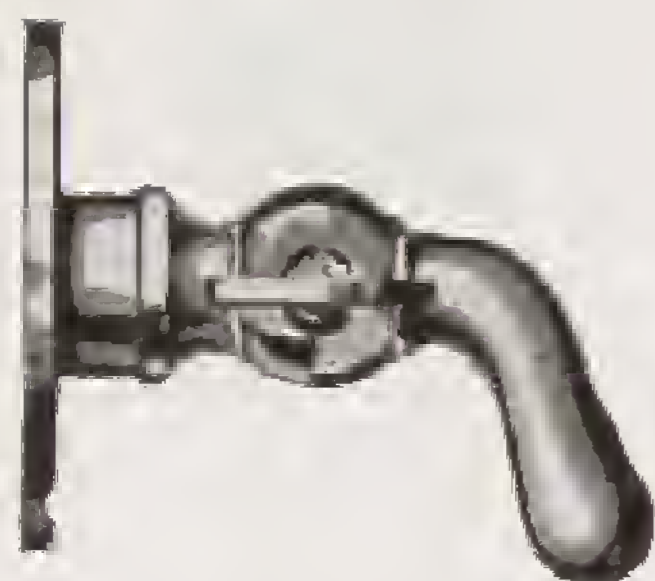

No. G 1092
BENT FLEXIBLE
BACK

Bright. For Brass.
 $\frac{3}{8}$ $\frac{1}{2}$ in.



G 215F or G 216M
FLEXIBLE TUBE COCK

$\frac{1}{8}$ $\frac{1}{4}$ $\frac{3}{8}$ $\frac{1}{2}$ in.



No. G 272
STOP COCK

For Lead. Rough.
 $\frac{1}{8}$, $\frac{1}{4}$, $\frac{3}{8}$, $\frac{1}{2}$ in.



No. G 154
BENT
FLEXIBLE
TUBE BACK
For Brass

$\frac{3}{8}$ $\frac{1}{2}$ in.

No. G 152
BACK
For Flexible Tube.
For Brass. Bright.

$\frac{3}{8}$ $\frac{1}{2}$ in.



LABORATORY FITTINGS



No. G 282
2-WAY

For Flexible Tube.
Bright. For Iron.
 $\frac{1}{8}$ $\frac{1}{4}$ in.



No. G 1024
3-WAY

Tapped at back for $\frac{1}{4}$ in.
Iron. Polished



No. G 1023
2-WAY

Tapped at back for $\frac{1}{4}$ in.
Iron. Stiff. Polished

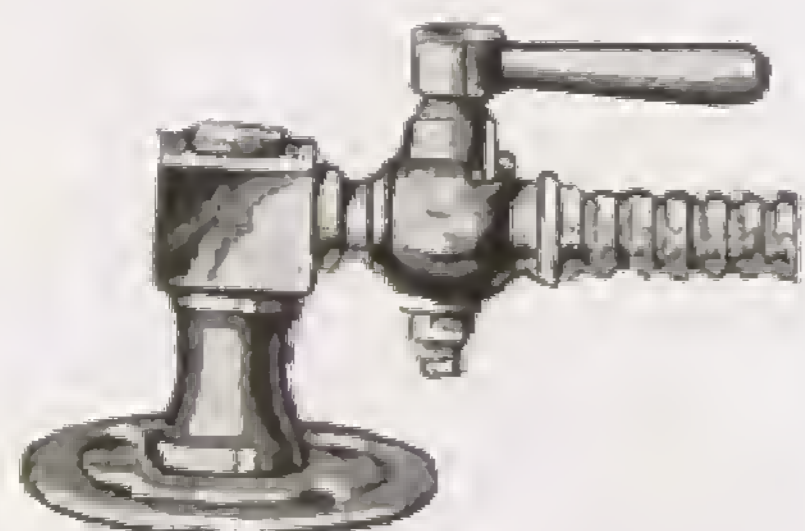

No. G 1095
1-WAY

With Baseplate tapped
 $\frac{1}{4}$ in. Iron or $\frac{1}{2}$ in. Brass.
Polished



No. G 1096
2-WAY

With Baseplate tapped
 $\frac{1}{4}$ in. Iron or $\frac{1}{2}$ in. Brass.
Polished



No. G 1097
2-WAY

Screwed Male.
Polished Brass Finish.
For Iron $\frac{1}{4}$ $\frac{3}{8}$ in.

BAXENDALE & CO. LTD.

BRASS GAS FITTINGS



No. G 287
ELBOW
CONNECTION

$\frac{3}{8}$ B \times 1 $\frac{1}{4}$, 1 $\frac{1}{2}$, 1 $\frac{3}{4}$, 2 in.

$\frac{1}{2}$ B \times 1 $\frac{1}{2}$, 1 $\frac{3}{4}$, 2 in.



No. G 355
No. G 355. STRAIGHT TUBE

Polished

Lengths : 3, 4, 6, 8, 10, 12 in.



No. G 221
NOSEPIECE

For Iron

$\frac{1}{8}$, $\frac{1}{4}$, $\frac{3}{8}$, $\frac{1}{2}$, $\frac{3}{4}$, 1 in.
 $\frac{3}{8}$ \times $\frac{1}{4}$, $\frac{3}{8}$, $\frac{1}{2}$ \times $\frac{1}{8}$, $\frac{1}{2}$ \times $\frac{1}{4}$ in.
 $\frac{1}{2}$ \times $\frac{3}{8}$, $\frac{3}{4}$ \times $\frac{1}{8}$ in.



No. G 224. Male
BULB NOZZLE

Bright. For Iron
 $\frac{1}{8}$ in., $\frac{1}{4}$ in., $\frac{3}{8}$ in.,



No. G 225. Female
BULB NOZZLE

Bright. For Iron
 $\frac{1}{8}$, $\frac{1}{4}$, $\frac{3}{8}$ in.



No. G 237 BRASS DIMINISHER For Iron
 $\frac{1}{4}$ \times $\frac{1}{8}$, $\frac{3}{8}$ \times $\frac{1}{8}$, $\frac{3}{8}$ \times $\frac{1}{4}$, $\frac{1}{2}$ \times $\frac{1}{8}$, $\frac{1}{2}$ \times $\frac{1}{4}$, $\frac{1}{2}$ \times $\frac{3}{8}$, $\frac{3}{4}$ \times $\frac{1}{4}$, $\frac{3}{4}$ \times $\frac{3}{8}$, $\frac{3}{4}$ \times $\frac{1}{2}$ in.
1 \times $\frac{1}{2}$, 1 \times $\frac{3}{4}$, 1 $\frac{1}{4}$ \times $\frac{1}{2}$, 1 $\frac{1}{4}$ \times $\frac{3}{4}$, 1 $\frac{1}{4}$ \times 1, 1 $\frac{1}{2}$ \times $\frac{3}{4}$, 1 $\frac{1}{2}$ \times 1 in.
1 $\frac{1}{2}$ \times 1 $\frac{1}{4}$, 2 \times $\frac{3}{4}$, 2 \times 1, 2 \times 1 $\frac{1}{4}$, 2 \times 1 $\frac{1}{2}$ in.

No. G 237A BRASS DIMINISHER For Brass
 $\frac{1}{2}$ \times $\frac{3}{8}$, $\frac{5}{8}$ \times $\frac{3}{8}$, $\frac{5}{8}$ \times $\frac{1}{2}$, $\frac{3}{4}$ \times $\frac{3}{8}$, $\frac{3}{4}$ \times $\frac{1}{2}$, $\frac{3}{4}$ \times $\frac{5}{8}$ in.

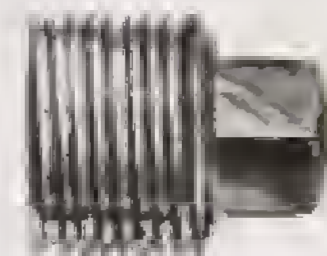

No. G 226
STOP PLUG

Bright. For Iron
 $\frac{1}{8}$, $\frac{1}{4}$, $\frac{3}{8}$, $\frac{1}{2}$, $\frac{3}{4}$, 1 in.



No. G 234
STRAIGHT
NIPPLE

For Iron
Sizes :

$\frac{1}{8}$, $\frac{1}{4}$, $\frac{3}{8}$, $\frac{1}{2}$, $\frac{3}{4}$, 1, 1 $\frac{1}{4}$,
1 $\frac{1}{2}$, 2 in.



No. G 234A
BARREL
NIPPLE

Sizes :

$\frac{1}{8}$, $\frac{1}{4}$, $\frac{3}{8}$, $\frac{1}{2}$, 1 in.

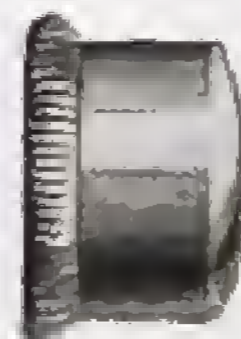

No. G 238
STOP CAP

For Iron
Sizes :

$\frac{1}{8}$, $\frac{1}{4}$, $\frac{3}{8}$, $\frac{1}{2}$, $\frac{3}{4}$ in.



No. G 293
BACKNUT

Bright. For Iron
Sizes :

$\frac{1}{8}$, $\frac{1}{4}$, $\frac{3}{8}$, $\frac{1}{2}$, $\frac{3}{4}$ in.

CHAIN

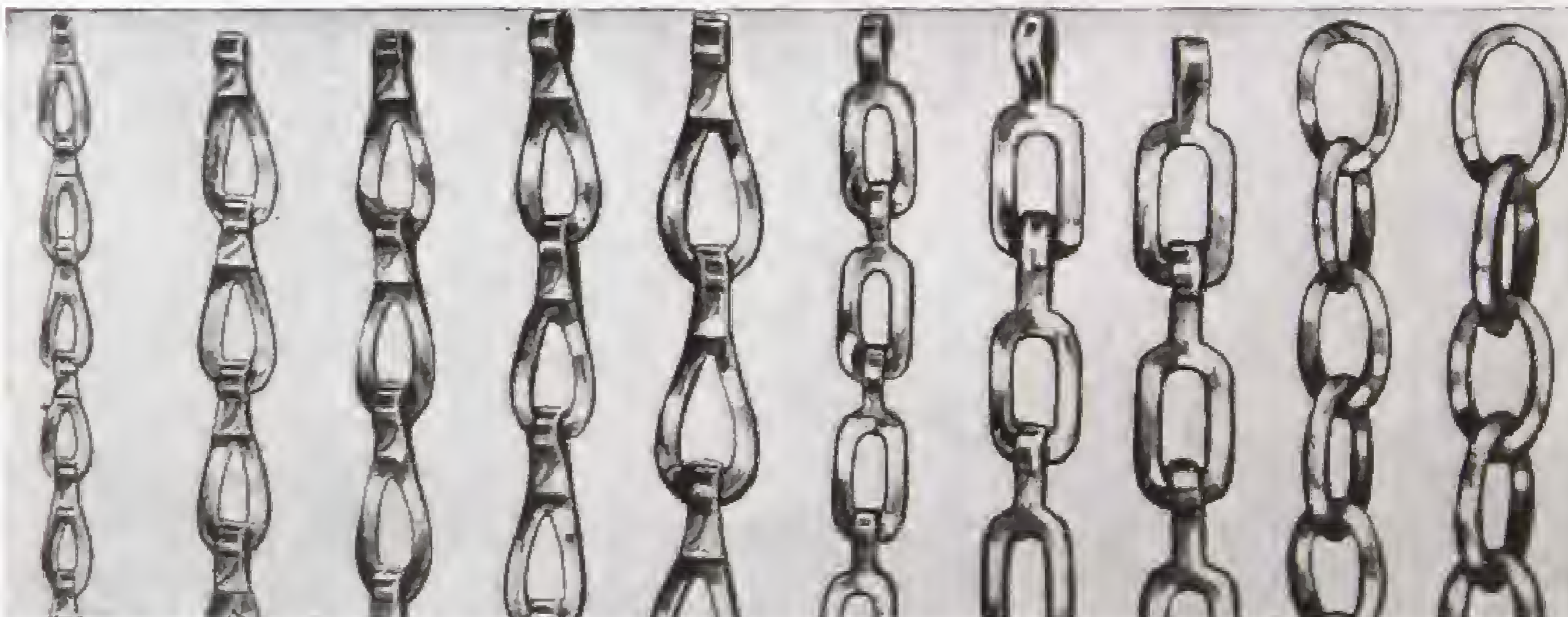

G 392 G 660 G 661 G 662 G 663 G 664 G 665 G 666 G 1006 G 1007
Polished Brass or Chromium-Plated Chain. In dozen yards

MILLER STREET · MANCHESTER

BRASS GAS FITTINGS



No. G 259
UNION
For Iron and
Lead. Tighted.

No. G 260
UNION
For Iron and
Lead. Tighted.

No. G 262
UNION
For Brass.
Tighted.

No. G 263
UNION
For Iron.

Sizes : $\frac{1}{8}$ $\frac{1}{4}$ $\frac{3}{8}$ $\frac{1}{2}$ $\frac{3}{4}$ 1 $1\frac{1}{4}$ $1\frac{1}{2}$ 2 in.

No. G 258A. CAP AND LINING

Long Tail.



$\frac{1}{4}$ $\frac{3}{8}$ $\frac{1}{2}$ $\frac{3}{4}$ 1 $1\frac{1}{4}$ $1\frac{1}{2}$ 2 in.

No. G 258A

No. G 267. ELBOW UNION

For Iron and Lead. Tighted.



$\frac{1}{4}$ $\frac{1}{2}$ $\frac{3}{4}$ $1\frac{1}{2}$ $2\frac{1}{2}$ in.

No. G 267

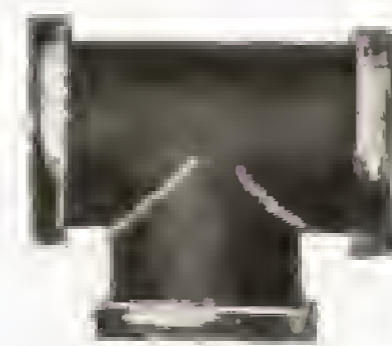

COUPLING

ELBOW

TEE

G 289

G 291 Round Rough.

G 292. Rough

$\frac{1}{8}$, $\frac{1}{4}$ \times $\frac{1}{8}$, $\frac{1}{4}$, $\frac{3}{8}$, $\frac{1}{2}$ in.

G 291A Square Rough

$\frac{1}{8}$, $\frac{1}{4}$ \times $\frac{1}{8}$, $\frac{1}{4}$ in.

G 289A for Brass

$\frac{1}{8}$, $\frac{1}{4}$ \times $\frac{1}{8}$, $\frac{1}{4}$, $\frac{3}{8}$, $\frac{1}{2}$ in.

$\frac{3}{8}$ in. B, $\frac{1}{2}$ in. B.

$\frac{3}{8}$ in. B, $\frac{1}{2}$ in. B.

GAS FITTINGS



No. G 409



No. G 413

FLEXIBLE METALLIC TUBING

With India-rubber Ends.

2 3 4 5 6 7 8 ft.

COMPOFLEX TUBING
With Rubber or Brass Male & Female ends

24, 36, 48, 72 in.

FLEXIBLE METALLIC TUBING

Inside diameter : $\frac{1}{4}$, $\frac{3}{8}$, $\frac{1}{2}$, $\frac{3}{4}$ in.

Per Coil of 60 ft.



No. G 817

RED RUBBER SEAMLESS GAS TUBING

$\frac{1}{2}$ $\frac{3}{4}$ 1 $1\frac{1}{2}$ in.

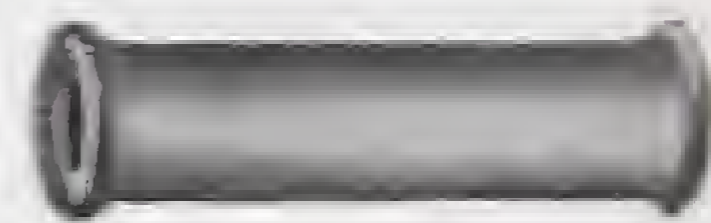

No. G 420

INDIA-RUBBER ENDS

$\frac{1}{4}$, $\frac{3}{8}$, $\frac{1}{2}$ in.

Plain, Beaded, Barrel Shape



No. G 393

BRASS "S" HOOKS
or Chromium-plated

$\frac{3}{8}$ 1 $1\frac{1}{2}$ $1\frac{3}{4}$ 2 in.

No. G 393 A

BELL "S" HOOKS
Brass or Chromium-plated.

$1\frac{1}{2}$ in.

No. G 394
BRASS OR CHROMIUM-PLATED SPLIT RINGS

$\frac{1}{2}$, $\frac{3}{4}$, 1 in.



GAS BLOCKS



No. G 1127. RED

4, 4 $\frac{1}{2}$, 5, 6 in.

No. G 1127 A.

BEST RED

4, 4 $\frac{1}{2}$, 5, 6 in.



GAS-HEATED WASH BOILERS

No. G 5806A

Galvanized casing with pressed steel top rim complete with lid. The tinned copper pan will take a normal size wash and the efficient ring pattern burner beneath it boils the water quickly. Mounted on three sturdy legs. Can be supplied without brass draw-off tap if required.



No. G 5808A

A square boiler of modern design finished in cream, green or white porcelain enamel with chromium-plated fittings. New design anti-condensation pan of 10 gallon capacity and fitted with Easy-Clean chromium-plated tap. Flush fitting cast-iron burner complete with patented lighting device and air adjuster. Mirror fitted to casing for easy burner inspection. Boiler mounted on castors.

Overall dimension: Height, 30 in.; Width, 17½ in.; Distance from Front to Back, 20½ in.; Height to Tap, 11¼ in.



No. G 757



No. G 647



No. G 756



No. G 646



No. G 649

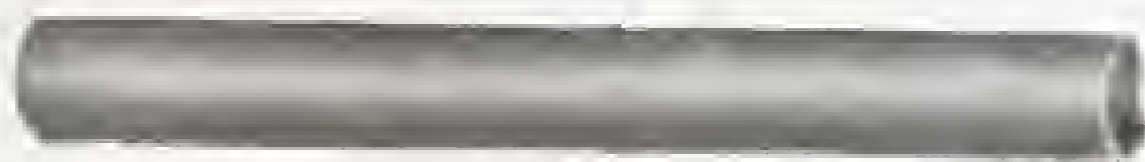

No. G 648

GALVANIZED FLUE PIPE AND FITTINGS

No. G 648. Pipe
In 1, 2, and 3-ft. lengths.
3 in., 4 in. (2-ft. lengths
only).

No. G 647
Round Elbow
3 in., 4 in.

No. G 646
Square Elbow
3 in.

No. G 757
H Piece
3 in., 4 in.

No. G 756
Tee Piece
3 in., 4 in.

No. G 649
Cowl
3 in., 4 in.

**ASCOT
INSTANTANEOUS SINK GAS WATER HEATER**
Types 503 and 503/1

For your kitchen the Ascot Sink Water Heater is ideal. It will give you an endless supply of hot, pure water for cooking, cleaning, washing and every other domestic purpose. The Ascot needs no attention, just turn the tap and hot water flows for as long as you wish. It is a money saver too, for gas is only used when hot water is being drawn off.

The sink heater, as all other Ascot heaters, is finished in gleaming white or cream vitreous enamel and chromium plate.

Example of Hot Water Services by Ascot

One therm of gas provides	Approximate Temperature °F.	Hot Water Per Minute
60 gallons for washing greasy dishes, etc.	150	$\frac{1}{2}$ gallon
OR		
85 gallons for toilet and general household purposes	120	$\frac{2}{3}$ gallon
OR		
120 gallons for other domestic purposes	100	1 gallon



Mean cold water inlet temperature taken as 50°F.

Choice of Tap Controls: for "Ascot" Water Heater.

Type 503—fitted with hot tap only.

Type 503/1—fitted with hot and cold taps.

GAS-HEATED WATER BOILERS

THE "AINTREE 393"

No Dirt, No Trouble, No Waiting,
Always Ready, Simple to Use,
Automatic in Operation.

Boiling Water in 30 seconds

The "Aintree 393" will give you 2-2½ pints of boiling water per minute, any time night or day.

For all domestic purposes; i.e., washing up, shaving water, baby's bath, etc.



**THE MAXOL Type MX 33/C
GAS HEATED INSTANTANEOUS WATER HEATER**

Dia.	Overall Height	Gas Connection	Water Connection	Flow of Water Per Minute
7 in.	With Spout 27 in.	$\frac{1}{2}$ in.	$\frac{1}{2}$ in.	Boiling: 2 pints
	Without Spout 19 in.			140°F.: 4 pints 100°F.: 8 pints

THE ASCOT MULTI-POINT GAS WATER HEATER

An unlimited and immediate supply of hot water available at any time, simply by turning the tap at the bath, sink, or lavatory basin.

Examples of Hot Water Services by Ascot

One therm of gas provides	Approximate temperature ° F.	Hot water per minute
60 gallons for washing up OR 85 gallons for toilet and general household purposes	150	1½ gallons
OR 5 HOT BATHS in 10— 15 minutes each bath ...	120	2 gallons
	120	2 gallons

Mean cold water inlet temperature taken as 50°F.

NOTE.—Type 709B is similar in function, appearance and output to type 709, but as additional features incorporates a water governor and temperature selector. It is essentially designed for MAINS CONNECTION where varying water pressures are encountered. Constant water flows are provided irrespective of water pressure fluctuations, the actual flow being variable according to the setting of the temperature selector.



No. 709/709B
Finished in White Vitreous Enamel.



THE ASCOT INSTANTANEOUS GAS BOILING WATER HEATER

Model RS/52/1

Set to Boiling and the Ascot gives two and a half to three pints of really boiling water each minute, suitable for making tea and cocoa, cooking, and sterilising, for it is as pure as the mains supply. Set to Hot and you get half a gallon of very hot water every minute, suitable for cooking, washing and cleaning.

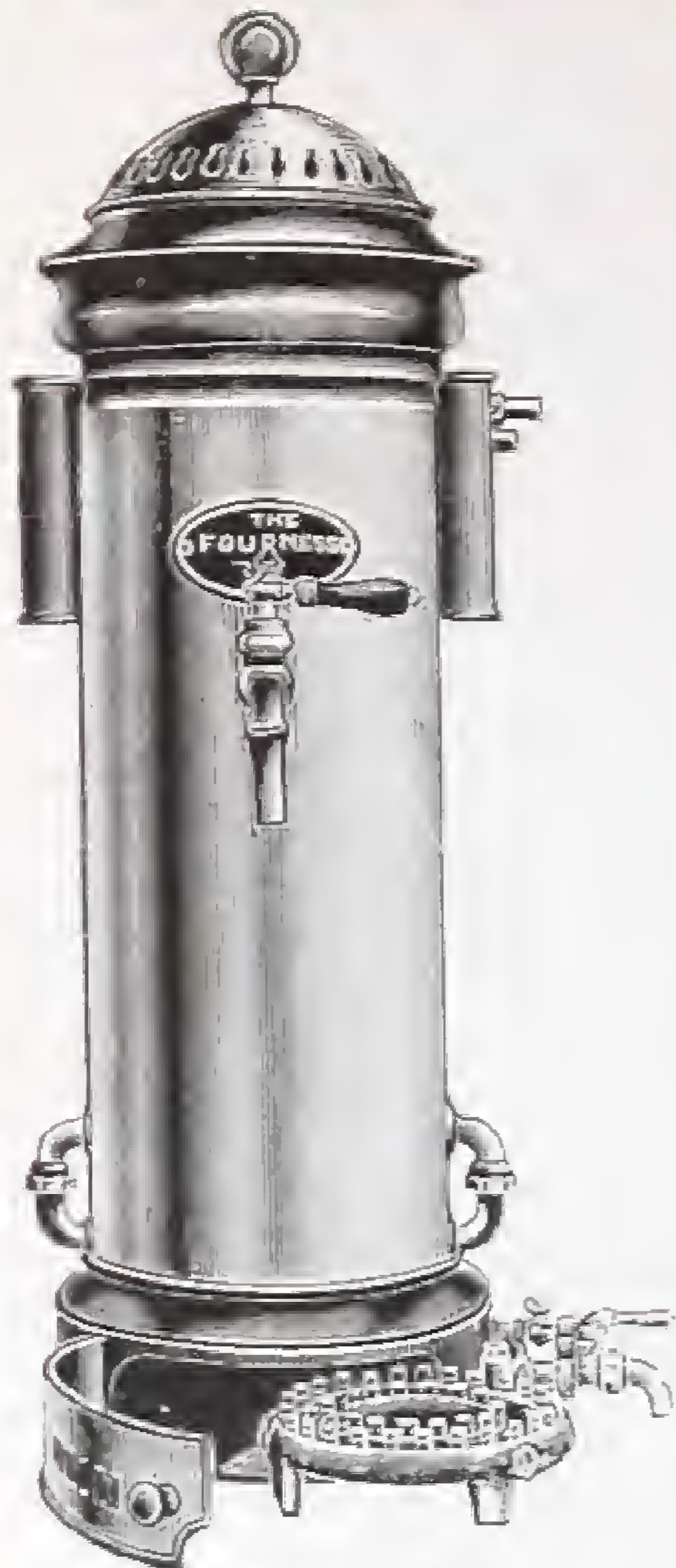

No. G 601
Illustration showing
Boiler Water Box

**THE "FOURNESS"
IMPROVED BOILERS FOR
SOFT WATER**

Self-Feeding.—Cannot burst or boil empty. Produces Boiling Water within Three Minutes of Lighting the Gas.

A cup or teapot can be filled without risk of scalding. Simple to work. Silent in operation. Made entirely of Copper, with all waterways plated with pure Tin. The water does not come in contact with the burnt gasses. The gas is only required to be full on while boiling water is drawn off. No attention requisite after lighting the gas.

Size	Boiling Water Produced Per Hour	Hot Water Per Minute
No.		
1	120 pints	1 gallon
2	220 "	1½ gallons
3	360 "	2 "

Extra if with Swing-out Burner for cleaning and renewals (not for lighting).

No. G 7503

FOURNESS WATER BOILER

For Soft Water

With best quality White Vitreous-enamelled Case, Chromium-plated Top, Base, Water Box, and Fittings.

Designed to meet the requirements of the smaller type of Hotels, Cafes, Boarding Houses, etc., where BOILING WATER is quickly required.

Produces 120 pints BOILING WATER per hour or 1 gallon HOT WATER per minute.

Swing-out Burner for cleaning and renewals (not for lighting).

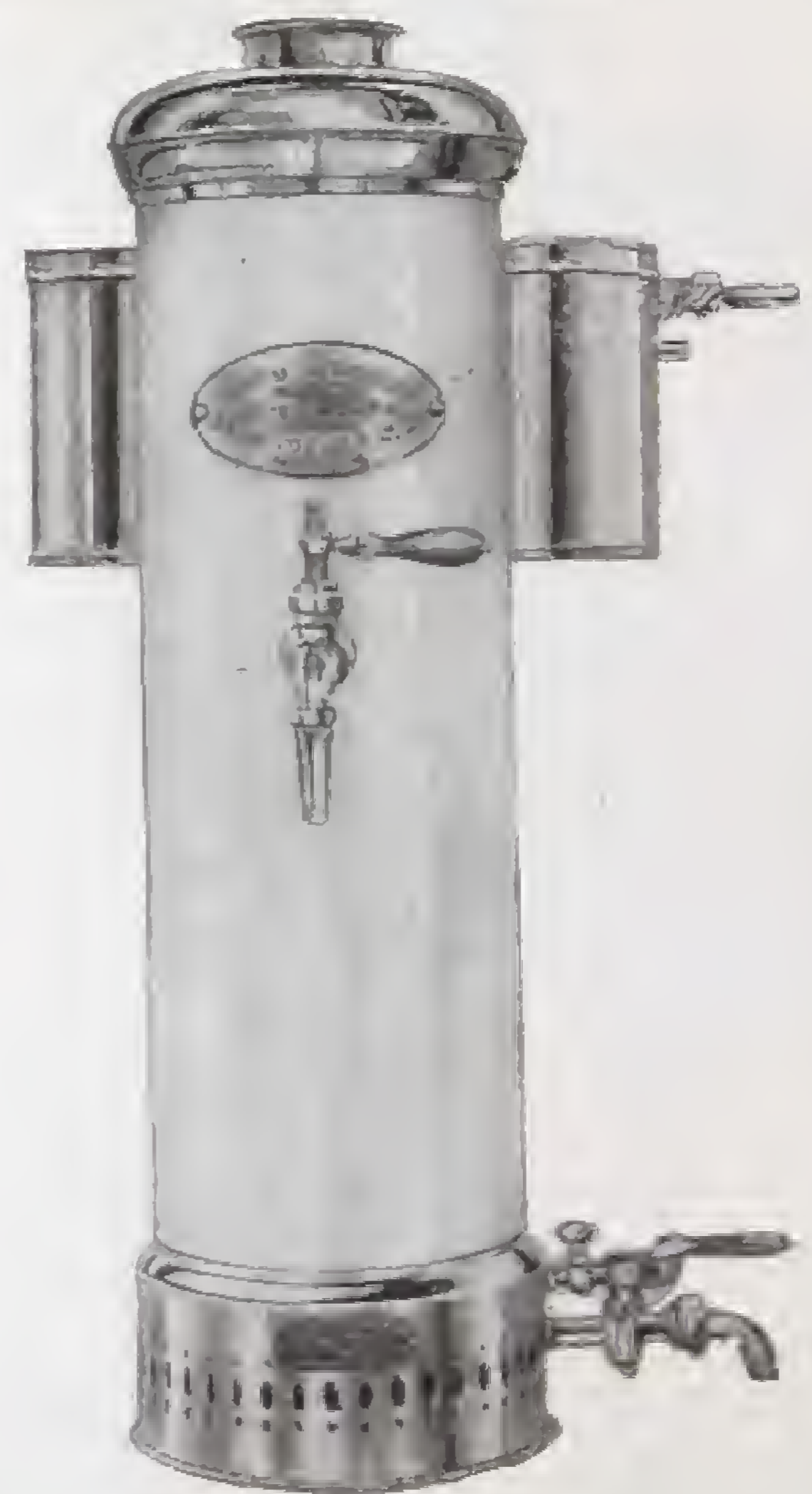

BAR FITTINGS



No. SF 1000

“ALMETAL” BEER ENGINE

Patent No. 278,079.

Case O.G. Moulded, mahogany top, enamelled white inside, heavy mounts, solid Quadrants fitted with Ebony or Plastic Handles and Bands, Cylinders fitted with Patent “ALMETAL” Buckets. Stainless Metal Arm Pipes, Union on rising main with cleaning eye. Complete with Stainless Steel Trough and Spanner.

Brass or Chromium-Plated Mounts | 2 3 4 5 6 pull

As no leather is used in the “ALMETAL” Cylinder, the Pull can be washed out with boiling water.

The Patent “ALMETAL” Bucket will last the life of the Cylinder.

No. S.F. 1001

“ALMETAL” Beer Engine Cylinder, ½ pint size, illustration shows the Patent “ALMETAL” Bucket.

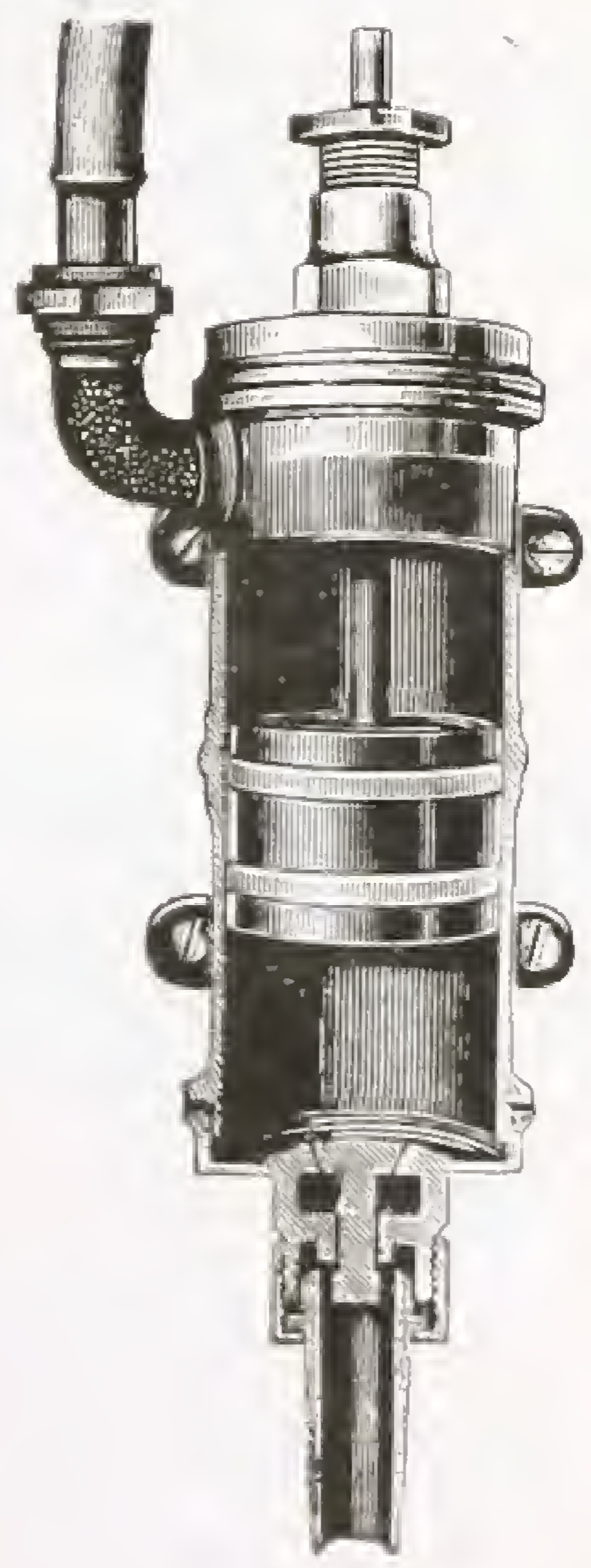

BAR FITTINGS



No. SF 310
STRAIGHT TAPPING COCK
 With or Without Square Union



No. SF 318
SPIRIT RACKING COCK
 $\frac{1}{2}$ $\frac{3}{8}$ $\frac{1}{2}$ 1 $1\frac{1}{4}$ in.



No. SF 741
STRAIGHT TAPPING COCK
 Extra Heavy.
 With or Without Wing Union



No. SF 317
SPIRIT RACKING COCK
 With Loose Key.
 $\frac{1}{2}$ $\frac{3}{8}$ $\frac{1}{2}$ 1 $1\frac{1}{4}$ in.



No. SF 314
BENT NOSE TAPPING COCK
 With or Without Square Union



No. SF 315
BEER COCK
 With Loose Key.
 Length, 8 in.

BAR FITTINGS

No. SF 311
BEER COCK

Extra Strong, with Rough Body.
Length, 8 in.

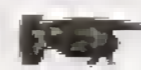

No. SF 312

With Rough Body. Length, 6 $\frac{3}{4}$ in.



No. SF 348

WINE BOTTLING TAP

Size : $\frac{1}{2}$ $\frac{5}{8}$ in. Brass

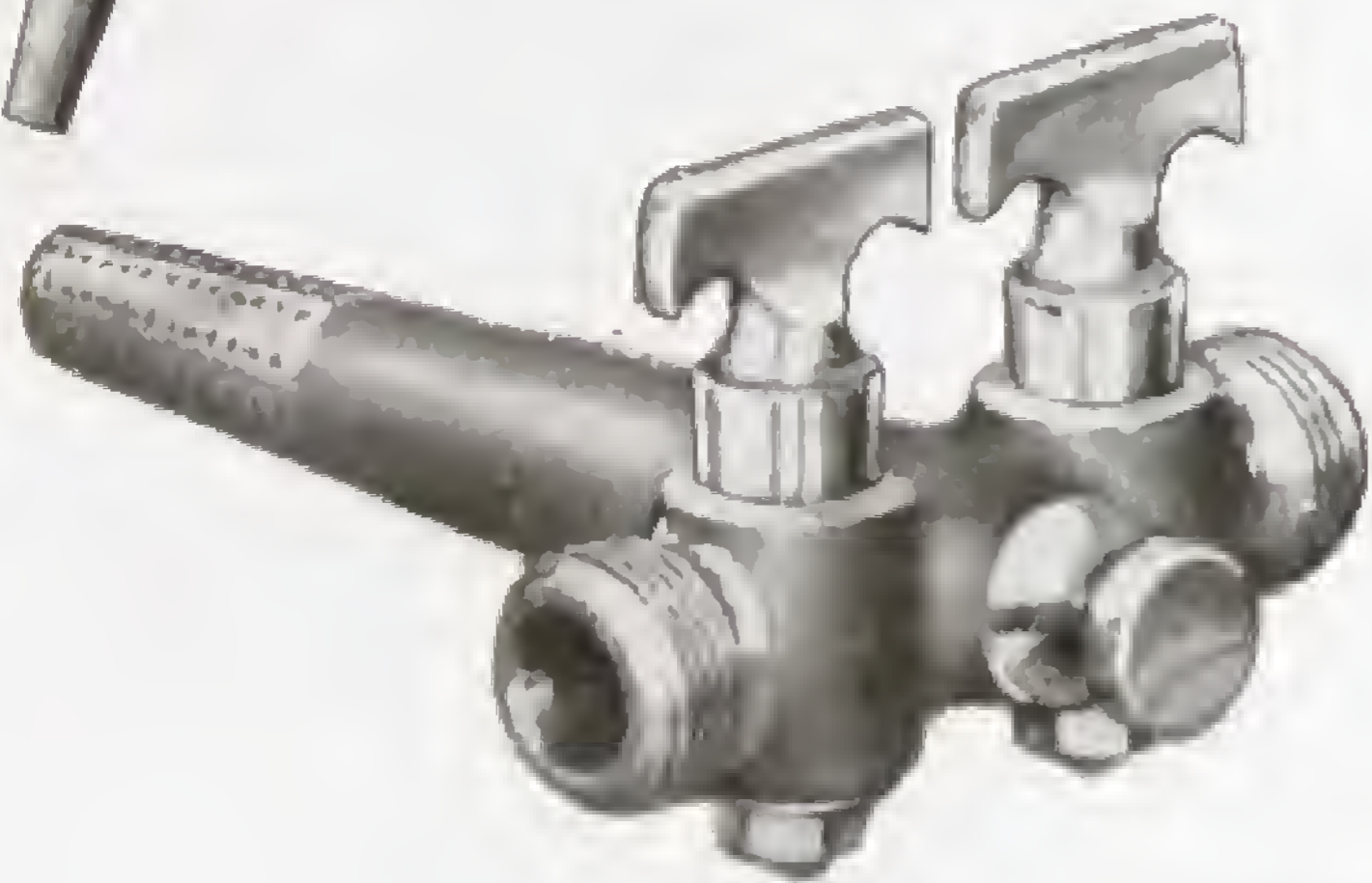

No. SF 319
TWO-WAY, TWO-PLUG
TAPPING COCK
With Unions

No. SF 320

TWO-WAY TAPPING COCK

With Unions

Single Plug



No. SF 750

FRONT TAP

Brass, Gun Metal, Beanco Silver,
Chromium-plated.

No. SF 751

EASYSLEEN FRONT TAP

With special nozzle attachment for
putting a sparkle on beer.

Brass, Gun Metal, Chromium-plated.

TREACLE AND URN TAPS



No. SF 723
IRON SYRUP or
TREACLE TAP



No. SF 722
IRON TREACLE TAP



No. SF 354
SPIRIT KEG TAP
With Taper Tail
Brass and Nickel Plated

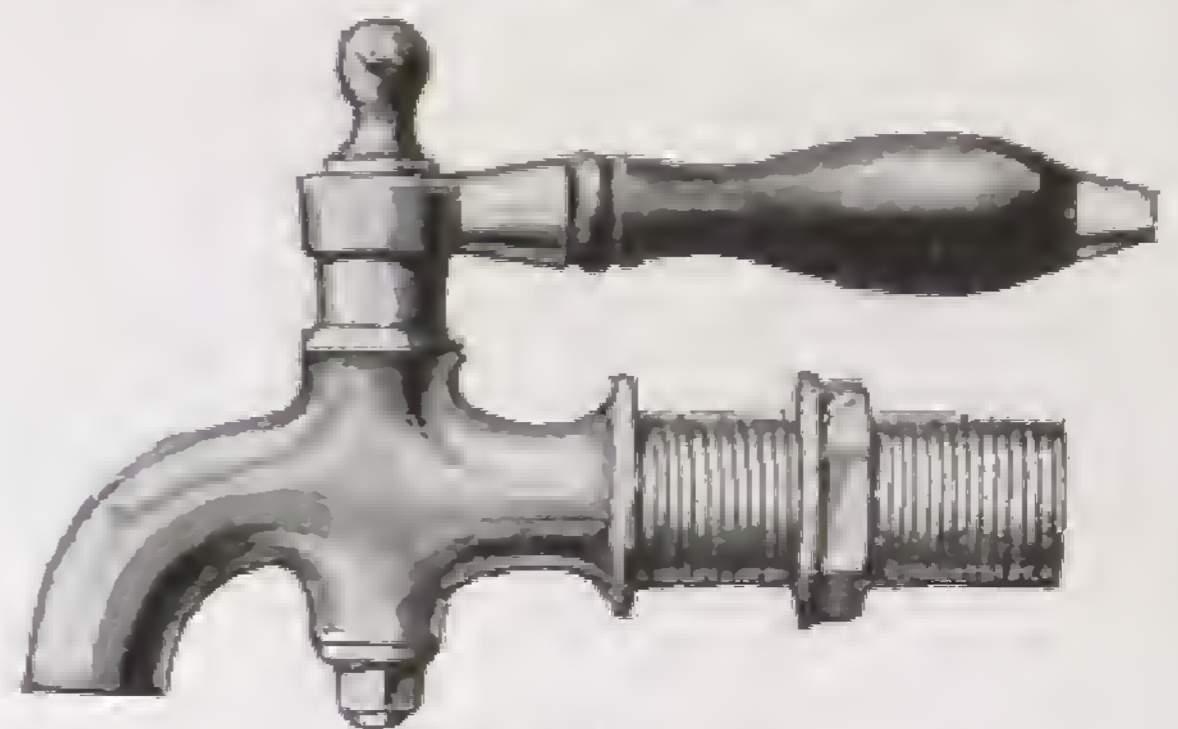

No. SF 745
BRASS URN TAP
With Ebony Handle, and Screwed
Shank with Backnut
Size $\frac{1}{2}$ $\frac{5}{8}$ $\frac{3}{4}$ ins.



No. SF 742
BRASS AND CHROME
PLATED URN TAP
With Ebony Handle, Screwed Shank
and Cleaning Screw fitted in nose
Size ... $\frac{5}{8}$ $\frac{3}{4}$ ins.



No. SF 744
BRASS AND CHROME
PLATED URN TAP
With Ebony Handle, Screwed Shank
Size ... $\frac{5}{8}$ $\frac{3}{4}$ ins.

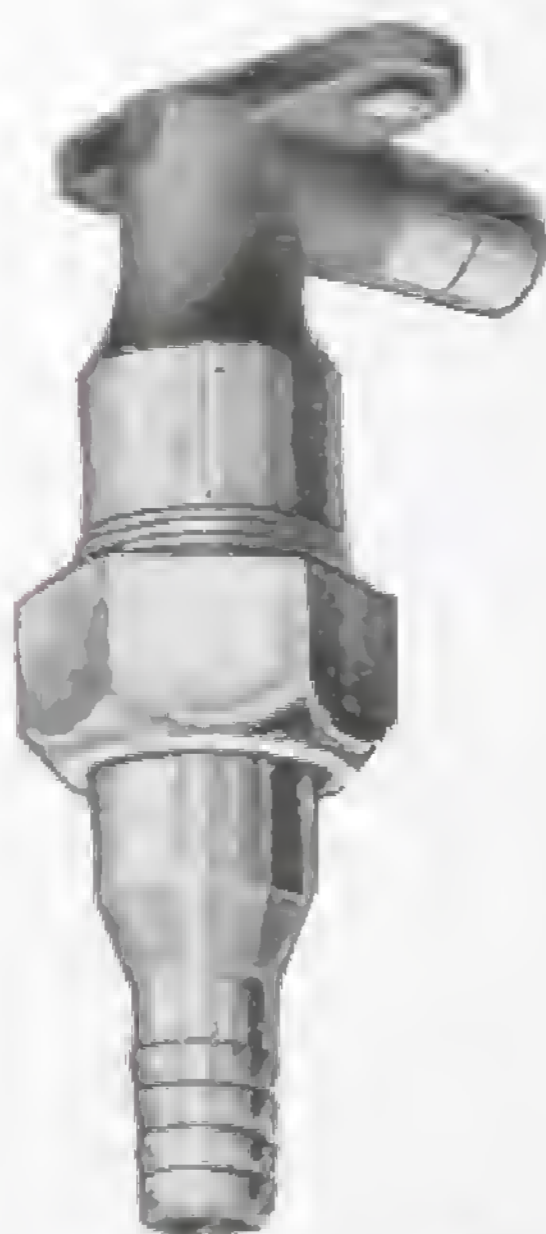

No. SF 435
CEILING UNION FITTED
WITH ASSISTING VALVE



No. SF 743
BRASS URN TAP
With Ebony Handle and Plain Shank
Size $\frac{1}{2}$ in.

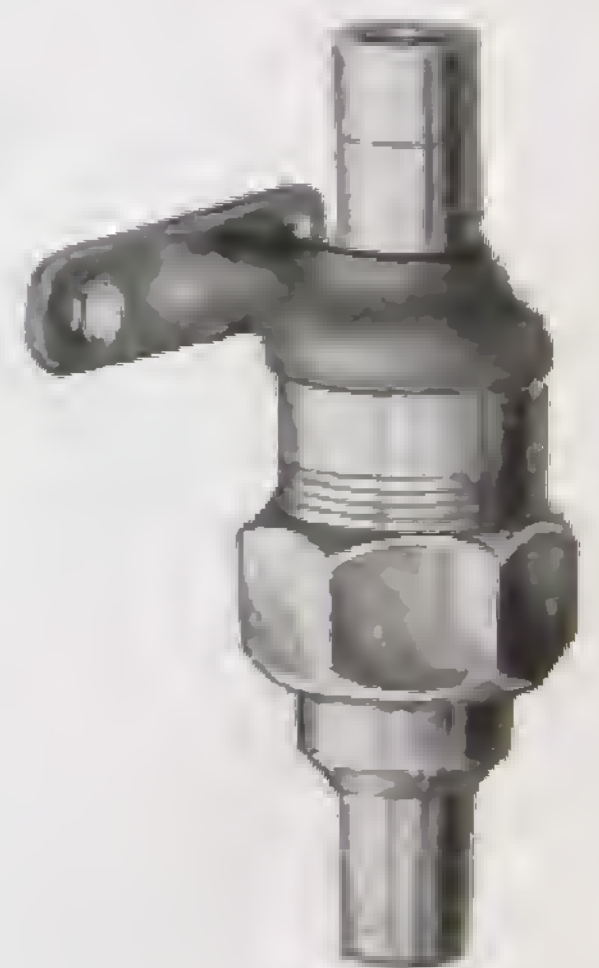

No. SF 331
ASSISTING VALVE

BAR FITTINGS



No. SF 756
**BRASS
LENGTHENING
UNIONS**

For Stainless Steel
Beer Pipe.
 $\frac{5}{8}$ in. outside dia.



No. SF 758
**BRASS
CEILING UNIONS**

With cleaning eye for
use with Telescopic
Drop Pipes and $\frac{5}{8}$
in. outside diameter
Stainless Steel Beer
Pipe.



No. SF 757
**BRASS
SERVICE PIPE
BEND**
Suitable for $\frac{5}{8}$ in. out-
side diameter Stain-
less Steel Beer Pipe.



No. SF 343
**TAPPING COCK
HOP STRAINER**



No. SF 341
**PUMP BUCKET
LEATHER**

Sizes
 $2\frac{1}{4}$, $2\frac{3}{8}$, $2\frac{1}{2}$, $2\frac{5}{8}$, $2\frac{3}{4}$, 3 in.



No. SF 337
**PAPER TAPPING
CONES**



No. SF 339
**COPPERED OR
NICKEL-PLATED
BEER TUBING
CLIPS**
Sizes ... $1\frac{1}{8}$ $1\frac{1}{4}$ in.



No. SF 342
**TAPPING COCK
WASHER**



No. SF 340
**BEER ENGINE
SPANNER**



No. SF 336
BLANK CAP



No. SF 754
**TRANSPARENT
PLASTIC
BEER PIPE**
 $\frac{5}{8}$ in. bore.



No. SF 344
**BRUSH FOR
CLEANING
BEER PIPES**



No. SF 755
**STAINLESS STEEL
BEER PIPE**
 $\frac{5}{8}$ in. outside diam. \times 21 g.
plug drawn inside,
polished outside.

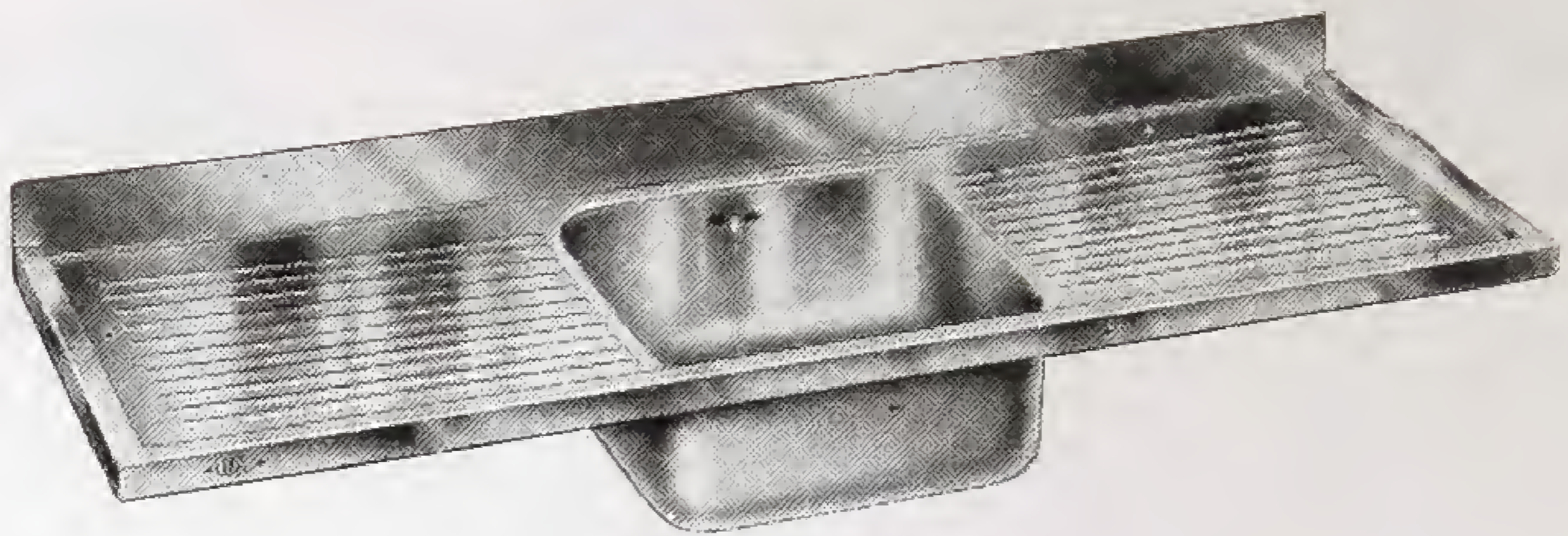

No. SF 752

STAINLESS STEEL BAR SINKS

With 3 in. splash back and straight fluted drain boards with pressed-in fall,
Size of bowl 15 in. \times 14 in. \times 7 in. complete with overflow, and $1\frac{1}{4}$ in.
waste, chain and plug.

Overall sizes: 36 in. \times 18 in. 42 in. \times 18 in. 48 in. \times 18 in.
54 in. \times 18 in. 60 in. \times 18 in. 66 in. \times 18 in. 72 in. \times 18 in.



No. SF 753

STAINLESS STEEL BAR SINKS

With Double Drainers and Double Bowls, $13\frac{1}{2}$ in. \times $13\frac{1}{2}$ in. \times $7\frac{1}{2}$ in. deep,
3 in. high back, $1\frac{1}{2}$ in. C.P. wastes, plugs, chains and overflows.

Overall sizes: 48 in. \times 18 in. 54 in. \times 18 in. 60 in. \times 18 in.
66 in. \times 18 in. 72 in. \times 18 in.

BAXENDALE & CO. LTD.



LEAD WOOL (For Jointing)

The joint should first be yarned with plain yarn (not tarred) and caulked back hard. The Lead Wool should then be twisted into a rope and each layer thoroughly caulked.

Material for Single Collar Joint.

For pressures up to 500 lbs. per square inch.

Diam.	Depth	Weight
in.	in.	lbs. oz.
2	1	1 1
3	1 1/4	1 10
4	1 1/2	2 2
5	1 3/4	2 10
6	1 3/4	3 12
7	1 3/4	4 13
8	1 3/4	5 5
9	1 3/4	6 6
10	1 3/4	8 0
12	1 3/4	9 9
14	1 3/4	11 11
15	1 3/4	12 12
16	1 3/4	13 5
18	1 3/4	15 15
20	1 3/4	17 9
24	1 3/4	20 12

Material for Double Collar Joint.

For pressures up to 500 lbs. per square inch.

FRONT OF SOCKET			BACK OF SOCKET		
Diam.	Depth	Weight	Diam.	Depth	Weight
in.	in.	lbs. oz.	in.	in.	lbs. oz.
2	1	1 1	2	1 1/4	0 9
3	1 1/4	1 1	3	1 1/4	1 1
4	1 1/4	2 2	4	1 1/4	1 1
5	1 1/4	2 10	5	1 1/4	1 1
6	1 1/4	3 12	6	1 1/4	1 1
7	1 1/4	4 4	7	1 1/4	2 2
8	1 1/4	5 5	8	1 1/4	2 10
9	1 1/4	6 6	9	1 1/4	2 10
10	1 1/4	8 0	10	1 1/4	3 3
12	1 1/4	9 9	12	1 1/4	4 4
14	1 1/4	11 11	14	1 1/4	5 14
15	1 1/4	12 12	15	1 1/4	6 6
16	1 1/4	13 5	16	1 1/4	6 15
18	1 1/4	15 15	18	1 1/4	8 0
20	1 1/4	17 9	20	1 1/4	8 8
24	1 1/4	20 12	24	1 1/4	10 2

PERFORATED ZINC

Stocked in sheets 8 ft. × 3 ft.

Flyproof quality, 8-hole, 6 Z.G.

Heavy „ 10-hole, 16 S.W.G.

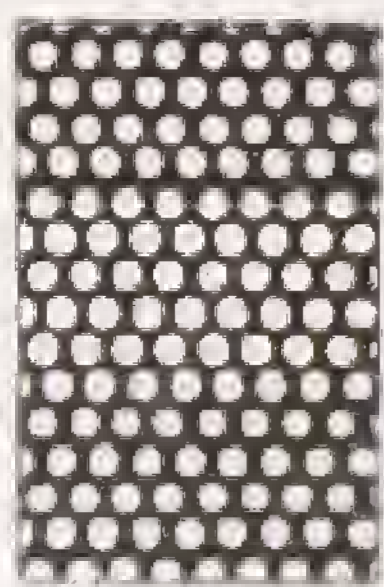

No. B 2940



No. B 2941



No. B 2942



No. B 2943

All other gauges and perforations supplied to order.

ZINC SASH BAR. ZINC SLATING NAILS and TACKS.

— Current prices on Application. —

LIVERPOOL · EDINBURGH · DUBLIN



A view taken in our lead mills

SHEET LEAD

APPROXIMATE WEIGHTS PER SHEET

lb. per ft. super		Size of Sheet				cwts. qrs. lb.		
2	3	4	5	6	30 ft. by 8 ft.			
2	3	4	5	6	30 ft. by 8 ft.	4	1	0
2½	3½	4½	5½	6½	" "	5	2	0
3	4	5	6	7	" "	6	2	0
3½	4½	5½	6½	7½	" "	7	2	0
4	5	6	7	8	" "	8	2	0
4½	5½	6½	7½	8½	" "	9	3	0
5	6	7	8	9	" "	10	3	0
5½	6½	7½	8½	9½	" "	11	3	0
6	7	8	9	10	" "	13	0	0
6½	7½	8½	9½	10½	" "	14	0	0
7	8	9	10	11	" "	15	0	0
8	9	10	11	12	" "	17	0	0

Other strengths to order.

LEAD WATER PIPES

Tinned inside if required.

Table of Standard Bores and Weights of Non-Chemical Lead Pipe

Bore in.	Standard Light Pipe		Standard Heavy Pipe		Basis Weights
	lbs. per yd.		lbs. per yd.		
¾	1½	...	3, 3½, 4, 5, 6, 7	...	3
1	2, 2½, 3	...	4, 5, 6, 7, 8, 9, 10	...	4
1¼	3, 3½, 4	...	7, 8, 9	...	5
1½	4, 5	...	6, 7, 8, 9, 10, 10½, 11, 12, 13, 14, 15, 16, 18	...	6
1¾	5, 6, 7	...	8, 9, 10, 12, 13, 14, 16, 17, 18, 21	...	8
2	5, 6, 7, 8	...	9, 10, 12, 14, 16, 18, 21, 22½, 23, 28	...	9
2½	7, 8, 9	...	10, 10½, 11, 12, 14, 15, 16, 18, 20, 24, 27, 30, 35	...	10
3	10, 12, 14	...	16, 18, 21, 22, 24, 25, 28, 30, 38	...	16
3½	12, 12½, 14, 16, 16½	...	} There are no standard heavy pipes in these bores	}	26
4	15, 17, 18, 20	...			36
4½	17, 18, 20	...			42
5	19, 20, 22, 23, 24, 26	...			48
6	22, 27, 29	...			50
7	30, 41	...			70
8	34, 57	...	90		

NOTE.—The basis weight of any bore not indicated in the above table shall be regarded as the same weight of the next larger bore.

BAXENDALE & CO. LTD.

ZINC

Table showing the Weights of various Gauges
of Zinc Sheets up to 21 Gauge.

ENGLISH ZINC GAUGE

Zinc Gauge	Nearest I.S.W.G.	Thickness dec. ins.	Ozs. per sq. ft.	Approx. Weight per Sheet	
				7 ft. x 3 ft. lbs. ozs.	8 ft. x 3 ft. lbs. ozs.
1	42	.004	2.4	—	—
2	38	.006	3.6	4 11	—
3	37	.007	4.2	5 8	6 5
4	35	.008	4.79	6 5	7 3
5	33	.010	5.99	7 14	9 0
6	32	.011	6.59	8 10	9 14
7	29	.013	7.79	10 4	11 11
8	28	.015	8.99	11 13	13 8
9	27	.017	10.19	13 6	15 5
10	25	.019	11.39	14 15	17 1
11	24	.022	13.18	17 5	19 12
12	23	.025	14.98	19 11	22 8
13	22	.028	16.78	22 0	25 3
14	21	.031	18.58	24 6	27 14
15	20	.036	21.57	28 5	32 6
16	19	.041	24.57	32 4	36 14
17	18	.046	27.57	36 3	41 6
18	—	.051	30.56	40 2	45 14
19	17	.057	34.16	44 13	51 4
20	16	.063	37.76	49 9	56 10
21	15	.070	41.95	55 1	62 15

IMPERIAL STANDARD WIRE GAUGE

Gauge No.	Thickness dec. in.	Weight per sq. ft. lbs. ozs.	Approx. Weight per Sheet	
			7 ft. x 3 ft. lbs. ozs.	8 ft. x 3 ft. lbs. ozs.
1	.300	11 3.79	236 0	269 11
2	.276	10 5.41	217 2	248 2
3	.252	9 7.02	198 3	226 9
4	.232	8 11.04	182 8	208 9
5	.212	7 15.05	166 12	190 9
6	.192	7 3.06	151 0	172 10
7	.176	6 9.48	138 7	158 3
8	.160	5 15.89	125 14	143 13
9	.144	5 6.3	113 4	129 7
10	.128	4 12.71	100 11	115 1
11	.116	4 5.52	91 4	104 4
12	.104	3 14.33	81 13	93 8
13	.092	3 7.14	72 6	82 11
14	.080	2 15.94	62 15	71 15

The weights shown are based on 1 square foot x 1 in. thick = 37.456 lbs. (Sp. Gr. 7.2) and all are subject to usual Works tolerance of half a gauge either way.

BAXENDALE & CO. LTD.

COPPER TUBES—USEFUL INFORMATION

BRITISH STANDARD SPECIFICATION No. 659—1955

Nominal Weights of Light Gauge Copper Tubes for Water, Sanitation and Gas

Nom. Size in.	Actual Out. Dia. in.	WATER AND GAS			SANITATION		
		Actual Bore in.	Thickness of Tube Wall	Lb. per ft.	Actual Bore in.	Thickness of Tube Wall	Lb. per ft.
			S.W.G.			S.W.G.	
$\frac{3}{4}$.596	.516	19	.27			
$\frac{1}{2}$.846	.766	19	.39			
1	1.112	1.016	18	.62	1.016	18	.62
$1\frac{1}{4}$	1.362	1.266	18	.76	1.266	18	.76
$1\frac{1}{2}$	1.612	1.516	18	.91	1.516	18	.91
2	2.128	2.016	17	1.40	2.032	18	1.21
$2\frac{1}{2}$	2.628	2.516	17	1.74	2.532	18	1.50
3	3.144	3.016	16	2.38	3.032	17	2.09
$3\frac{1}{2}$	3.660	3.516	15	3.12	3.548	17	2.44
4	4.184	4.024	14	3.97	4.056	16	3.19

COPPER TUBES FOR SCREWING

TABLE OF B.S. Tab. 1 THREADS AND COPPER TUBES

Nominal Size in.	No. of Threads per in.	Standard Outside Dia. in.	Thickness S.W.G.	Theoretical Weight per foot lb.
$\frac{1}{2}$	20	0.650	13	0.658
$\frac{3}{4}$	20	0.902	13	0.958
1	20	1.168	12	1.414
$1\frac{1}{4}$	20	1.418	12	1.746
$1\frac{1}{2}$	20	1.668	12	2.079
2	16	2.194	10	3.394
$2\frac{1}{2}$	16	2.694	9	4.684
3	16	3.218	9	5.648

TABLE OF B.S. Tab. 2 THREADS AND COPPER TUBES

Nominal Size in.	No. of Threads per in.	Standard Outside Dia. in.	Thickness S.W.G.	Theoretical Weight per foot lb.
$\frac{1}{2}$	14	0.837	11	1.060
$\frac{3}{4}$	14	1.054	10	1.517
1	11	1.324	9	2.163
$1\frac{1}{4}$	11	1.665	8	3.051
$1\frac{1}{2}$	11	1.897	7	3.823
2	11	2.363	6	5.247
$2\frac{1}{2}$	11	2.976	5	7.411
3	11	3.476	4	9.484

MILLER STREET · MANCHESTER

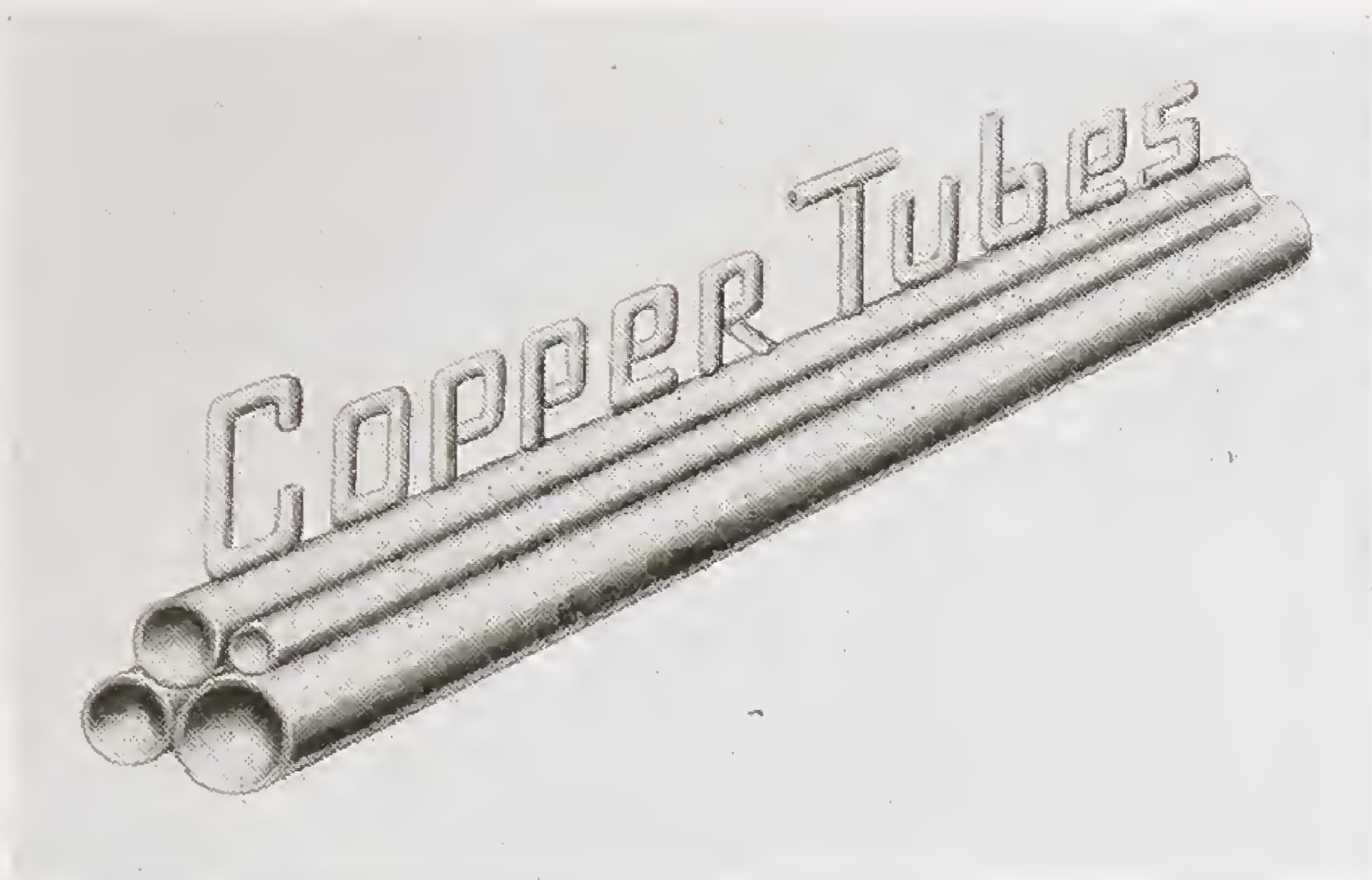

LIGHT GAUGE COPPER TUBES B.S.S. 659/1955

For water, gas, and sanitation, suitable for domestic use. Can be connected by compression or capillary fittings or by bronze or autogenous welding.

In random lengths 15/20 feet; for sizes and further details, see Tables on page 224.

UNDERGROUND COPPER TUBE

B.S.S. 1386/1947

For burying underground for the conveyance of water, town gas, etc.

Tubes with nominal bores between $\frac{1}{2}$ in. and $1\frac{1}{4}$ in. inclusive, are normally supplied in coils of 50/60 feet, but $\frac{1}{2}$ in. and $\frac{3}{4}$ in. sizes can be manufactured in coils of 100 feet.

Nominal bore in.	Outside diameter in.	S.W.G.	Approx. weight lbs. per ft.
$\frac{1}{2}$	0.596	18	0.319
$\frac{3}{4}$	0.846	17	0.536
1	1.112	16	0.812
$1\frac{1}{4}$	1.362	16	1.006

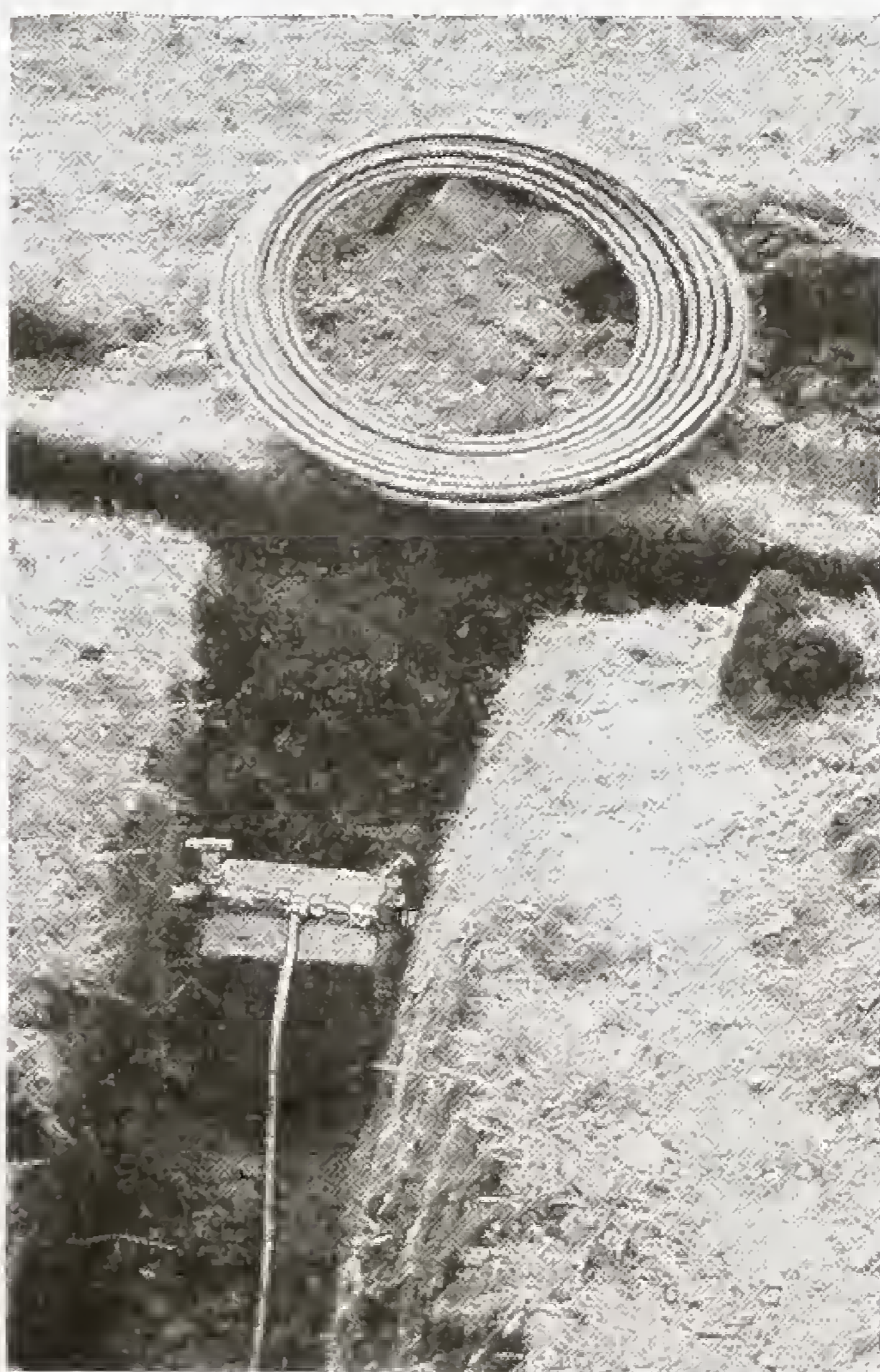

METALS FOR ROOFING

COLD ROLLED COPPER SHEET

For Flashing and Roofing—Soft Quality, in coils 50 feet to 75 feet long.



Width	S.W.G.	Approx. Weight per coil
24 in.	26	1 cwt.
30 in.	26	1 cwt.
36 in.	26	1½ cwts.

SUPER PURITY ALUMINIUM

99.99%

For Flashing and General Roofing Work.

Stocked in 20 S.W.G. Rolls weighing approximately 28 lbs. per roll.

Widths : 24 in. 30 in. 36 in.

Approximate Coverage per roll = 55 sq. ft.



We are Stockists of :—

CERROBEND — a low temperature melting alloy — the ideal filler for all types of tube bending.

CERROMATRIX — a low temperature melting expanding alloy — reduces costs in all forms of tool making and engineering.

POLYTHENE TUBE B.S.S. 1972

A plastic tubing for cold water supply, which maintains its properties at low temperatures and has excellent resistance to corrosion. This new versatile material offers many advantages where speedy installation is an important factor. Supplied in two gauges as details given below.

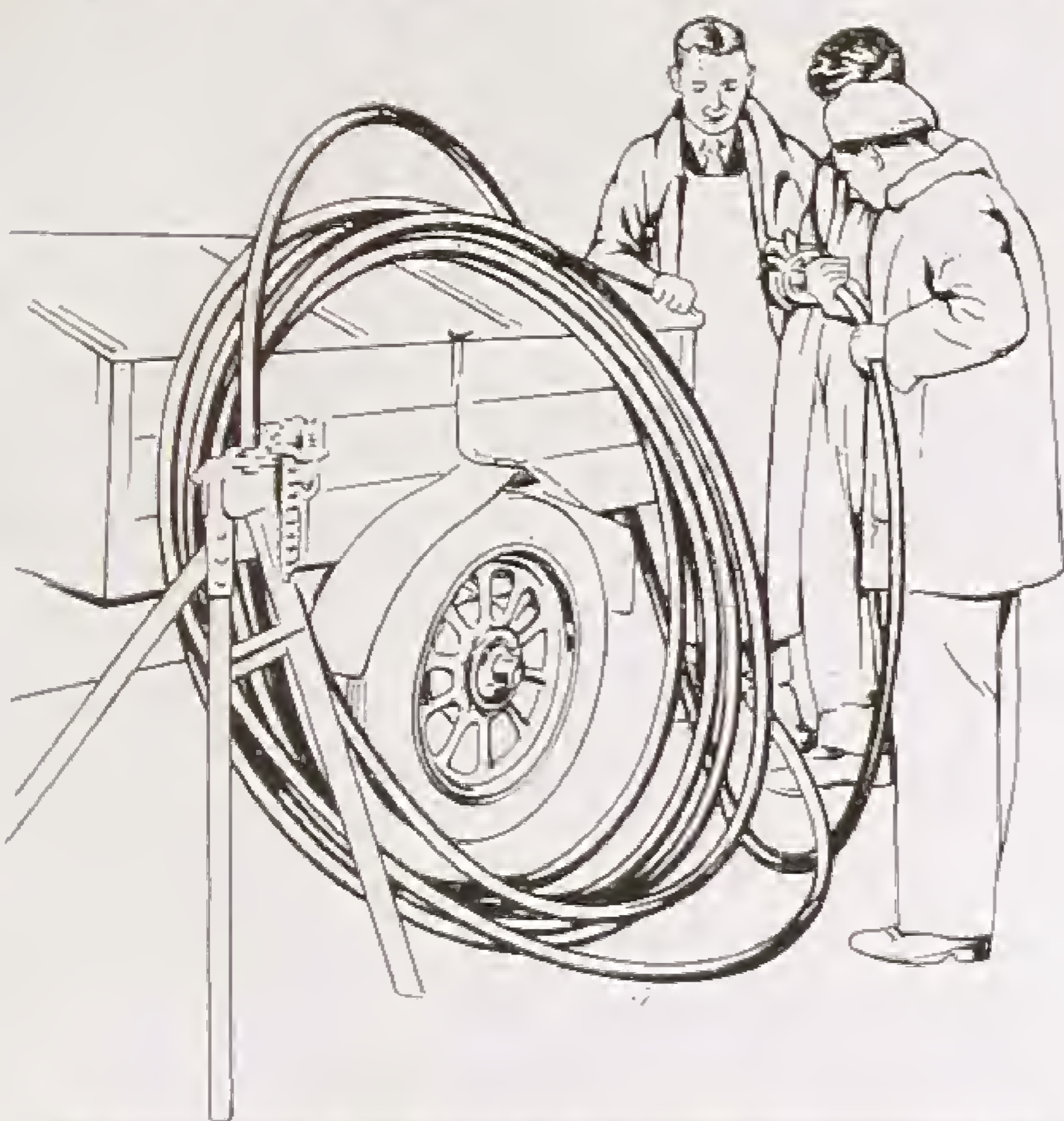

Normal Gauge | Heavy Gauge

Nom. bore in.	Wall thickness in.	Weight per 100 ft. lbs.	Wall thickness in.	Weight per 100 ft. lbs.
1/2	0.093	7	0.173	15
3/4	0.125	14	0.173	21
1	0.125	17.5	0.173	27
1 1/4	0.125	21.5	—	—
1 1/2	0.140	28	—	—
2	0.187	51.5	—	—

Sizes up to 1 1/2 in. are available as coils in lengths of 100 to 500 ft. 2 in. bore in straight lengths to suit customers' requirements.

SOLDER AND BEARING METAL

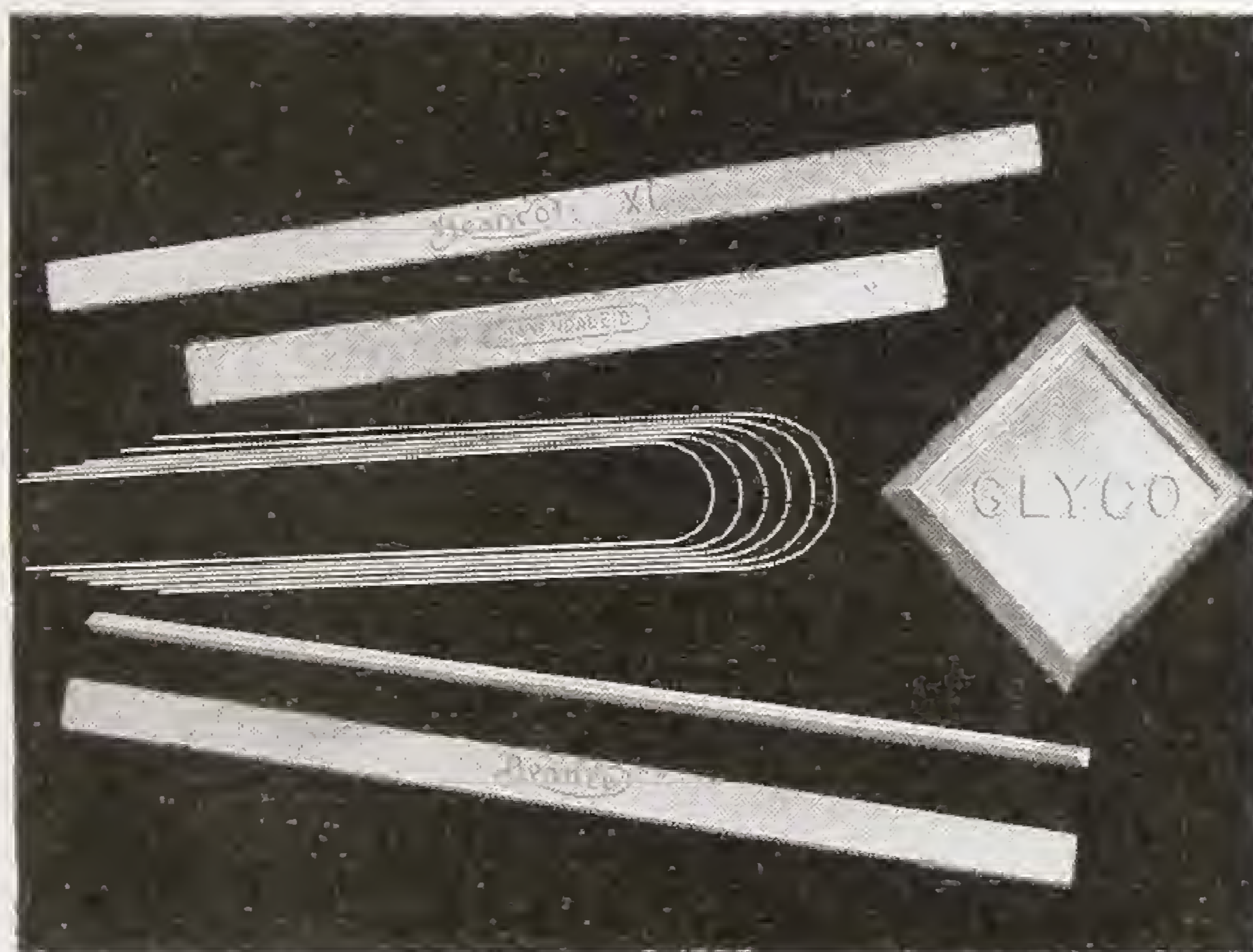

- Beanco XL. Plumbers' Solder—a super-fine quality, rich in tin.
- Beanco 'D' Plumbers' Solder—a reliable solder made to B.S. Grade 'D' Specification.
- Beanco Plumbers' Solder—a good working solder dependable for uniform quality.
- Tinman's Solder—for all general purposes, in 1/2 lb. sticks.
- Blowpipe Solder—a recommendable quality in 2 oz. strips.
- Glyco Bearing Metal—for use in general engineering—in approximately 4 lb. ingots.

BAXENDALE & CO. LTD.

RAWLPLUGS

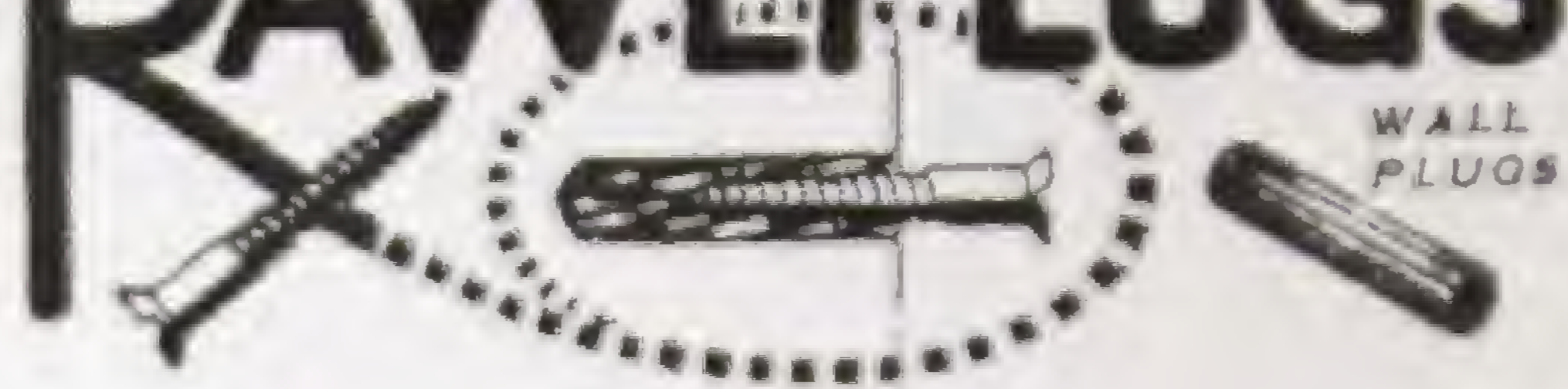

USE RAWLPLUGS
FOR ALL YOUR
FIXING JOBS

THE RAWLPLUG METHOD

Is the only reliable method of doing fixing jobs with screws in any material. It is based on the scientific principle of expansion. When a screw is driven into a Rawlplug, the plug expands and grips the wall like a vice, thus ensuring a strong permanent fixture. We sell Rawlplugs and Rawlplug Tools that are suitable for every fixing job.



RAWLBOLTS No. IR 2799 TWO TYPES

There are two types of Rawlbolts. Both work on the same fundamental principle. The only difference is that in one the expanding member is part of the bolt itself and on the other it is detachable. A glance at the illustrations will make this quite clear. Bolt protruding type is for use on jobs where the shell and bolt can be inserted in the hole together. Loose Bolt type is for use where the bolt has to be inserted after the shell and expanding member have been placed in position. The unique feature about this type is the attachment of the nut. The extended leg portion of the segment acts as a claw and prevents the nut falling off, and also stops the nut rotating. This type is specially valuable



when fixing heavy machinery to concrete beds where it is difficult to lift the machinery over the hole.

All sizes from 1/8 in. to 1 in. thick stocked. Also drills to suit.

MILLER STREET · MANCHESTER

NAILS, TACKS, RIVETS, Etc.

STEEL CUT CLASP

—
CUT CLOUT

—
CUT SPRIGS

—
CUT FLOOR BRADS

—
PLASTERERS' CUT LATH

—
GLAZING SPRIGS

—
PATENT STEEL CLASP

—
PATENT STEEL ROSE

—
PATENT STEEL GATE NAILS

—
WROUGHT HAND-MADE
SLATE Galvanized.

—
WROUGHT COUNTERSUNK
CLOUT

—
PIPE NAILS

—
BEST WIRE DOWEL NAILS

—
WIRE PANEL PINS

—
IMPROVED RELIABLE TACKS

Fina. Fine Tinned. Improved Strong.
Improved Strong Tinned.

—
GIMP PINS

In 1-lb. Packets.

Black Wire.

Black Cut Gimp Tacks.

Brass Gimp Pins.

French Reliable Steel Gimp Pins.

BEST ROUND WIRE

—
BEST BRIGHT OVAL WIRE

—
WIRE CLOUT AND SLATE

—
WIRE LATH

—
SLATE NAILS

Zinc, Cut Steel, Cut Copper,
Round Wire Copper, Aluminium.

—
COPPER SLATE NAILS

—
COPPER BOAT NAILS

(Square Wire.)

Rose and Countersunk Heads.
Copper Roves for ditto. All sizes.

—
COPPER DISC RIVETS OR
CRAMPONS

For Fixing Asbestos Sheets

—
COPPER TACKS

Cut and Wire

—
STRAIGHT HOLDFASTS

—
SPUR HOLDFASTS

—
BENT HOLDFASTS

—
CUT TACKS

Fine Blue.

Strong Blue.

Fine Tinned.

Strong Tinned

—
ESCUTCHEON PINS

In 1-lb. Packets. Brass and Brassed.

RIVETS

In Mild Steel, Copper and Aluminium.
Flat Head, Countersunk Head, Round Head, Pan Head,
Copper Rivets and Washers.

We have always on hand large stocks of

SCREWS, BOLTS AND NUTS, COACH SCREWS, ETC.

Current Prices, quoted on application.

GALVANIZED CORRUGATED SHEETS

For Roofing, etc.

Sheets longer than 9 ft. are charged at extra rates



Made in 18 20 22 24 and 26 W Gauge

Eight 3 in. Corrugations, covering 2 ft. wide when fixed. Sheets 4 ft. to 10 ft. long. Also made with ten 3 in. Corrugations, covering 2 ft. 6 in. width.

Curved Sheets for Span Curved Roofs, Special Buildings, etc., can be supplied bent to any radius or shape.

FITTINGS FOR GALVANIZED CORRUGATED SHEETS

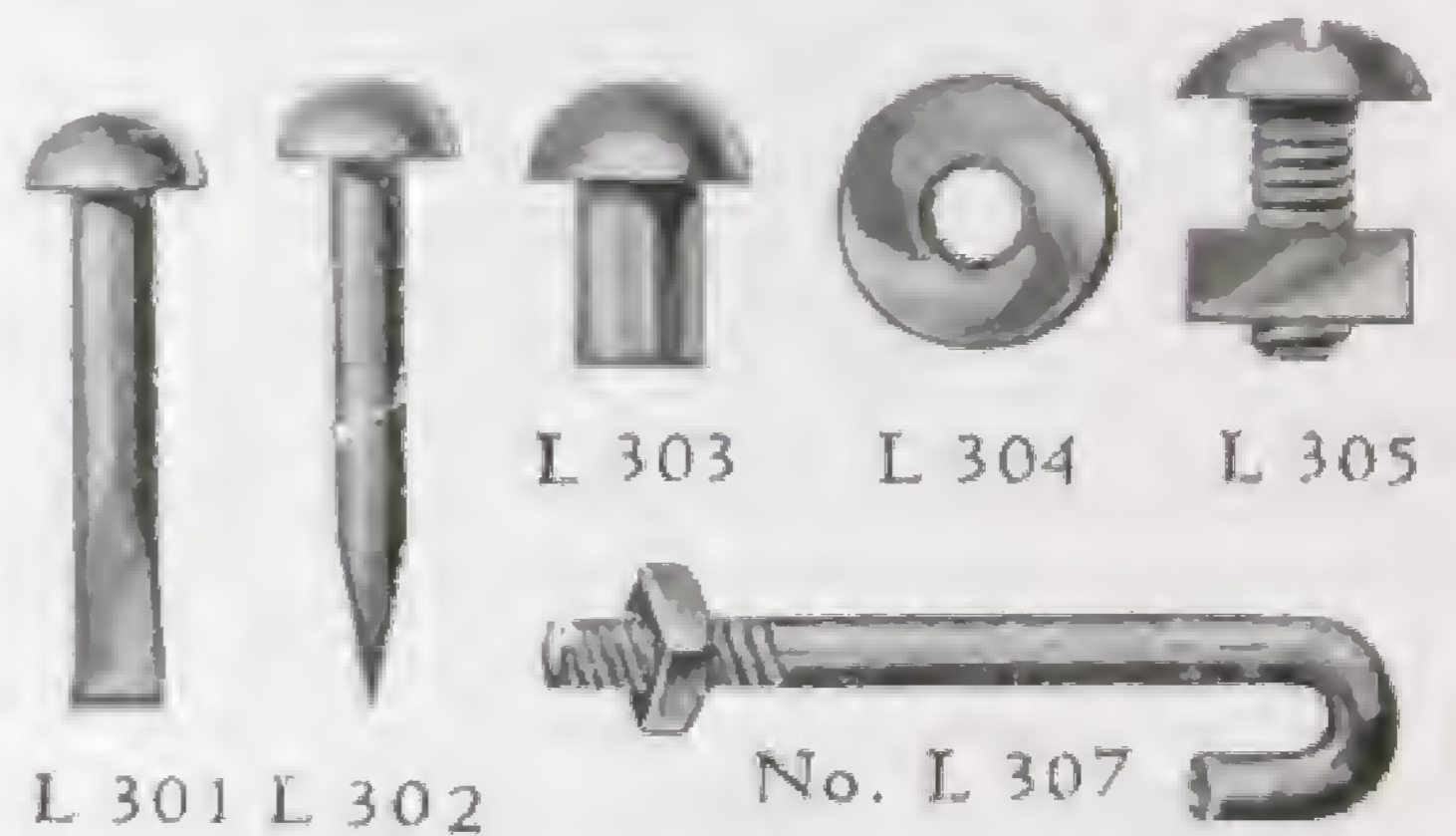

No. L 308

No. L 308 GALVANIZED CURVED WASHERS

1 1/4 in. or 1 1/2 in. x 1/2 in. or 3/4 in. hole. 14 G.

LEAD AND FELT WASHERS

Can also be supplied

GALVANIZED RIDGING

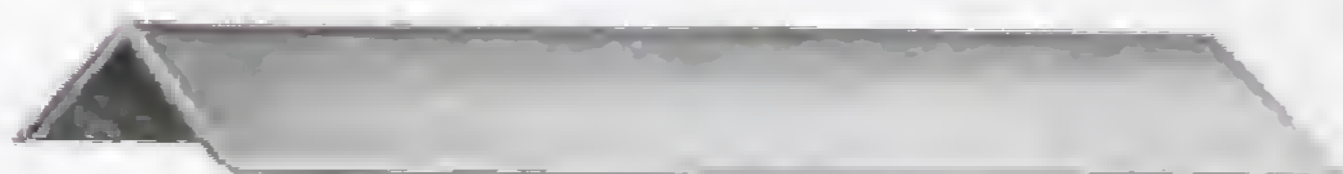

No. L 309

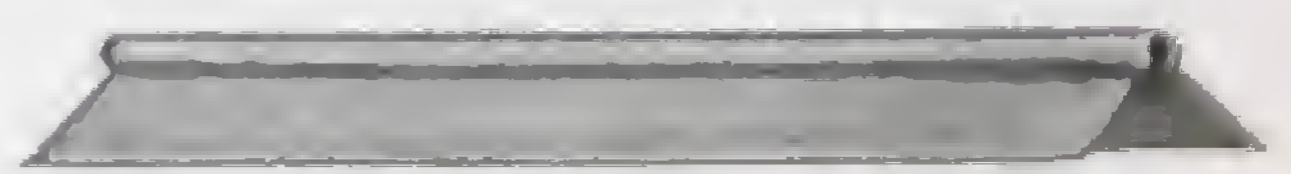

No. L 310

For Roofing Felts see pages 236-237.



**GALVANIZED CORRUGATED
ROOF LIGHTS**

Made of Mild Steel Sheets.
Also used as Side Lights in corrugated buildings.
The Opening Lights have a day-light 36 in. × 18 in.
and the Dead Lights 36 in. × 20 in. but any size
made to order.
Length : 5, 6, 7, 8, 9, 10 feet.
Gauge : 20, 22, 24, 26.
Glass extra.

DEADLIGHT No. G 5896

All made to suit the ordinary 8/3 Corrugations of
Roofing Sheets and supplied ready for fixing.

10/3 Corrugation can also be supplied when desired,
and also to fit Asbestos Sheets.

Length : 5, 6, 7, 8, 9, 10 feet.

Gauge : 20, 22, 24, 26.

Glass Extra.

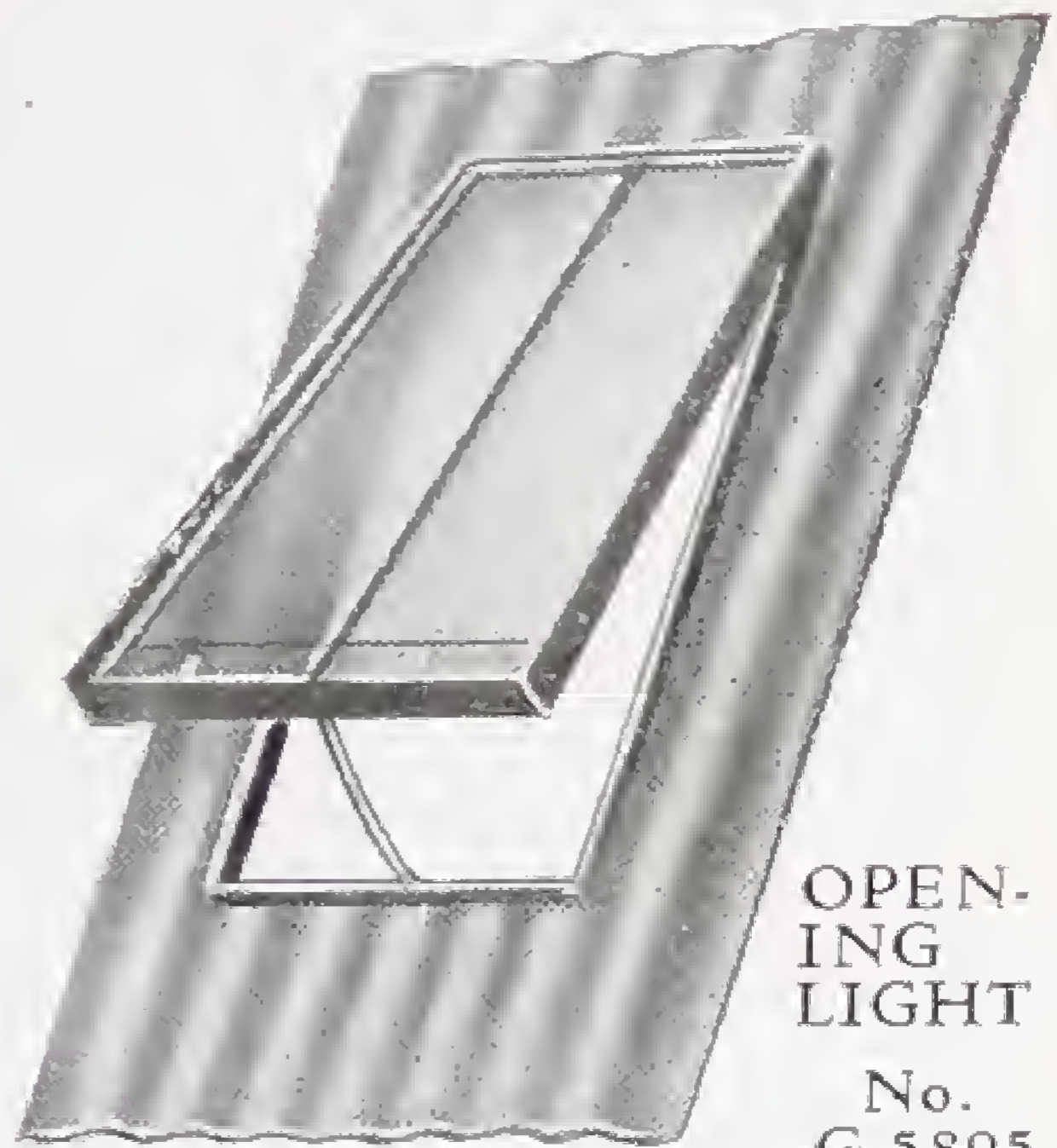

**OPEN-
ING
LIGHT**

**No.
G 5895**

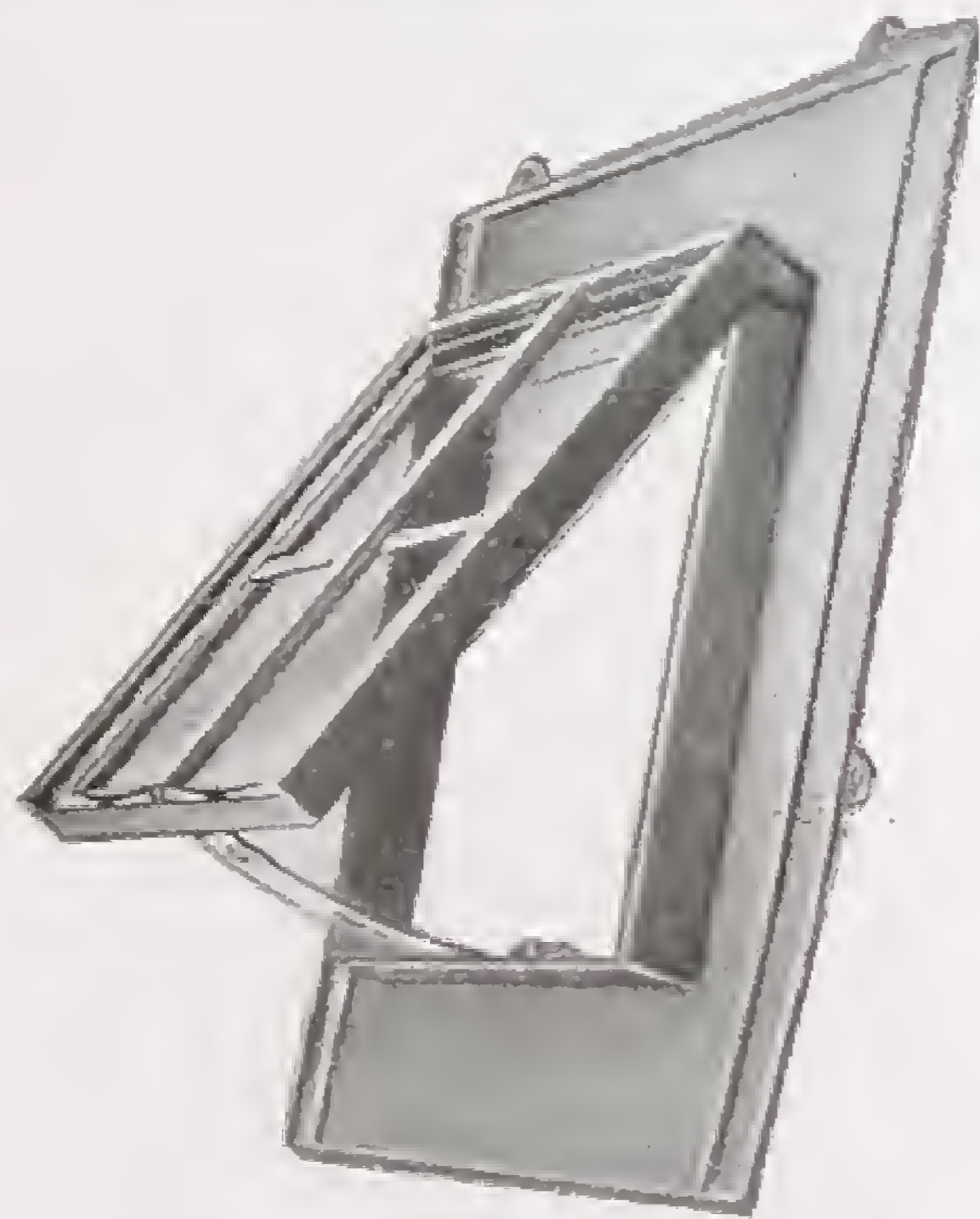

**No. G 5891
OPENING LIGHTS
Painted**

**CAST-IRON
ROOF LIGHTS**

Margins : 3 in. Sides.

4 in. Top.

4 in. Bottom.

No. G 5892

**DEAD LIGHTS
Painted**

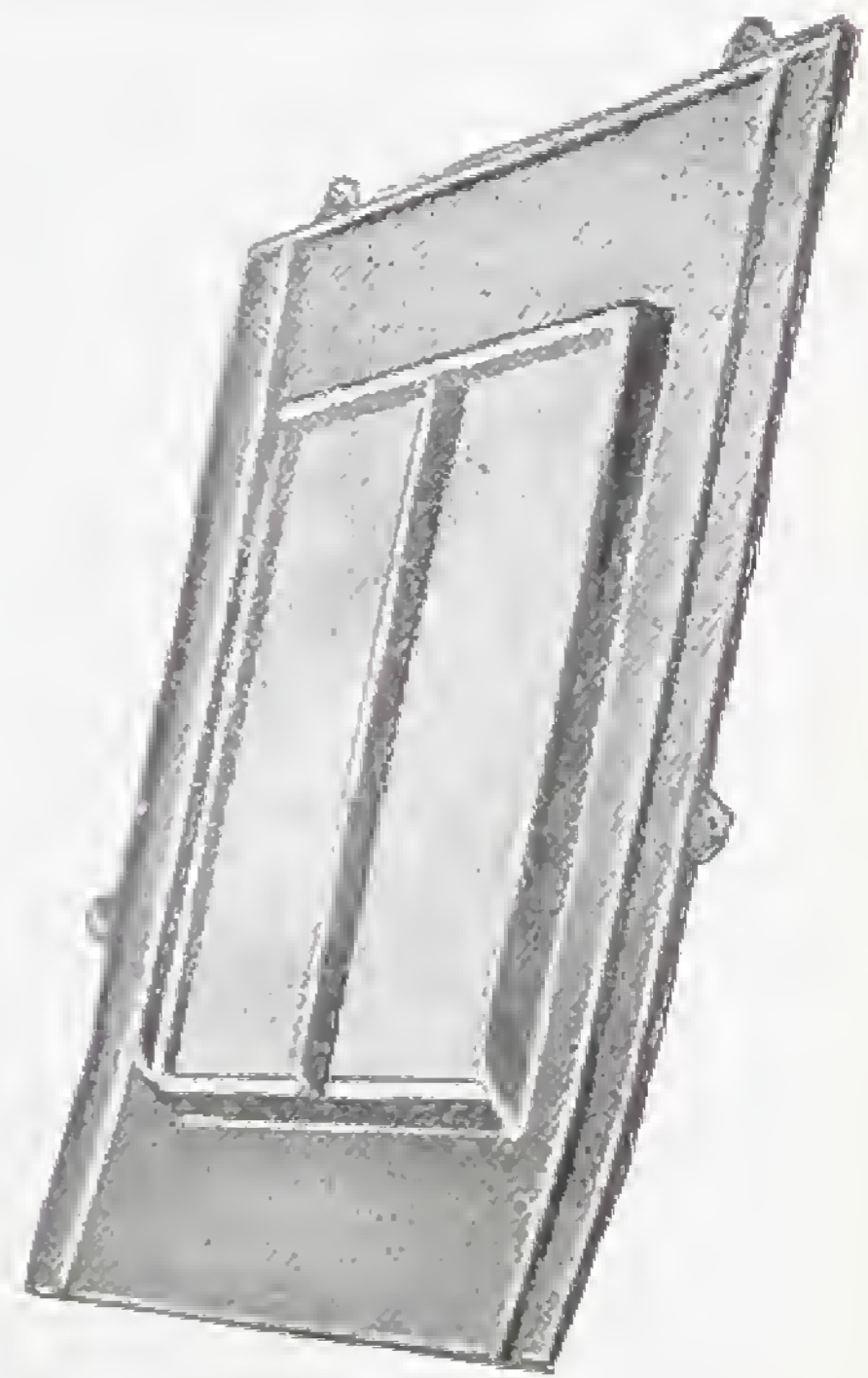

Daylight Sizes :

NOTE.—When ordering, please give width first, then height.

Inches						
12 × 16	16 × 24	18 × 30	20 × 30	24 × 30	24 × 42	30 × 42
14 × 20	18 × 24	18 × 36	20 × 36	24 × 36	30 × 36	36 × 48

Glass extra

If fitted with quadrant and pulley, extra. If fitted with Leggott's Openers, No. 3, No. 5,
No. 7, extra. Preparing Roof-lights for Leggott's Openers extra.

**PARAMOUNT (Regd.)
IMPROVED ROOF VENTILATING SKYLIGHT
FOR TILED OR SLATE ROOF**

The new attachment actually prevents snow and rain getting through and allows fresh air to pass freely into the room. Particularly suitable for Housing Schemes, but also entirely satisfactory for Other Houses, Out-Buildings, Garages, and the like.



Strong Sheet, or
Rough Cast Glass
can be supplied
with Ventilators,
if required,
at an extra cost.

No. V 1104

Special Features.—Weatherproof. Continuous ventilation. Any slope and type of roof will accommodate this Ventilator. Fixing is arranged as the roof-work proceeds and therefore no additional expense incurred.
Economies.—No tackle is required for opening as the Ventilator is of the fixed type. It is just secured down to the rafters and lead flashing is unnecessary. Cast-iron. Painted.

Dimensions :

15 x 24 in. (Daylight opening size)

19 x 31 in. (Overall opening size)

Special prices for quantities.

No. V 1103

HOPPER AND LOUVRE. Permanent and Adequate Ventilation.



Indispensable in rooms where Gas Fires, Cookers, etc., are used or for rooms without fireplaces. An absolute safeguard against rain, etc., getting through under any conditions because it has **Anti-Weather Bars**. It is mouse-proof. Another feature is that it has a **Mortar Rib** which enables it to be permanently secured in the wall.

Size 9 x 6 in. Cast-iron, painted one coat

Special prices for quantities.

PARAMOUNT (Regd.) VENTILATING WINDOW FRAMES

Cast-iron. Suitable for Housing Schemes, etc.



Front View.

No. V 1100. PANTRY LIGHT
Continuous Fresh Air. Perfect Cleanliness.

Absolutely Weather-proof.

The Canopies provided at the top and bottom are cast at such an angle as to promote and ensure a steady continuous current of fresh air night and day.

There is a loose fitted perforated Zinc Screen at the back of each Canopy, clamped on by a cast-iron frame, thereby making it easy to detach the screen for cleaning purposes, and also permits of the addition of a clean linen or other woven fabric air filter, if desired by the householder. With the fast Zinc Screen, filth accumulates in the recesses, and the perforation gets clogged up.

- (a) The lower inside edge of the clamping frame is sufficiently chamfered, so that if rain or moisture gets through the perforation it runs down the screen and is deflected out of the frame.
- (b) The clamping frame is fastened with Thumb Screws which make the detachment and attachment very simple and easy.

Size : $13\frac{1}{2} \times 26$ in. One canopy at top only or two canopy (as illustrated)

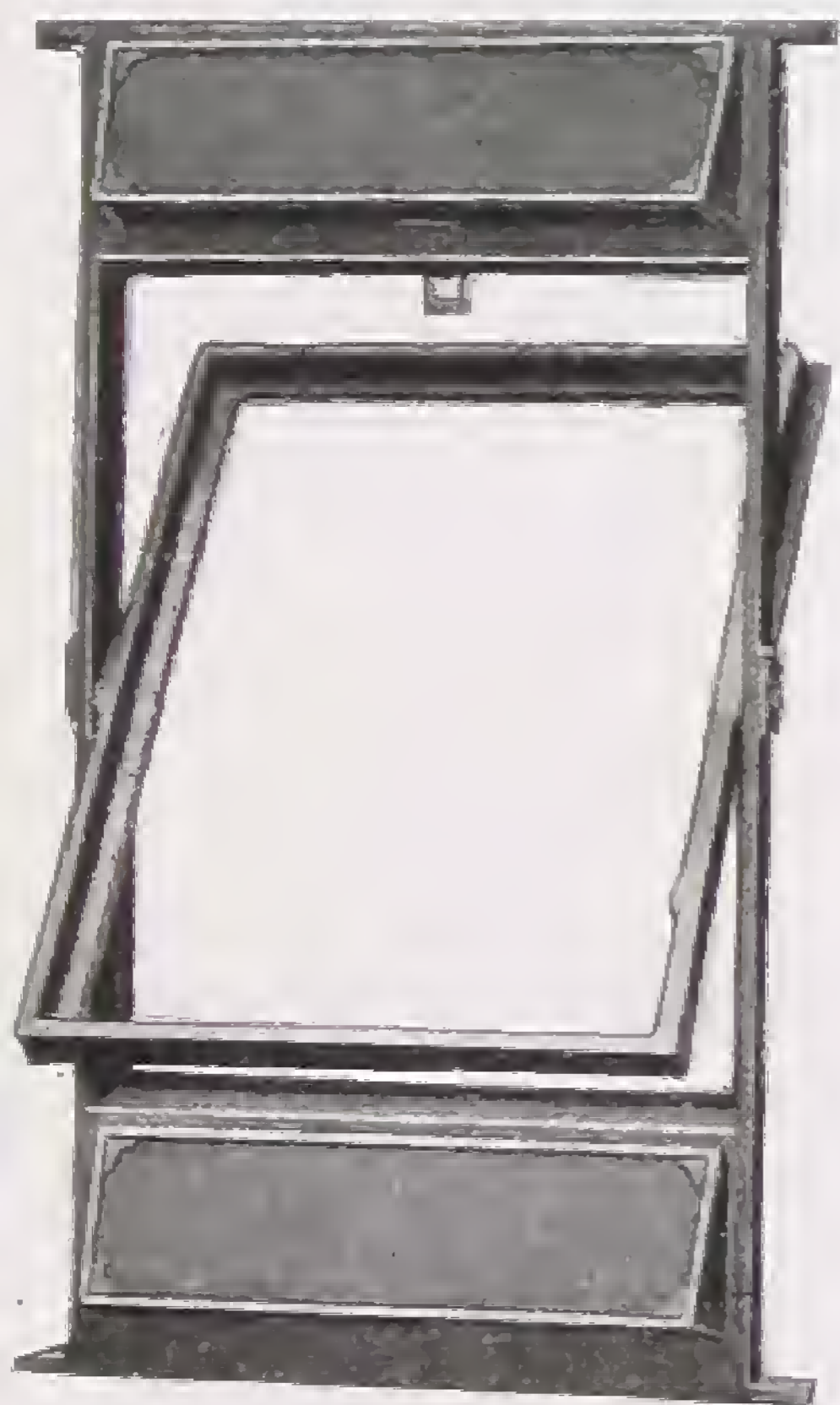

External View.

No. V 1101
W.C. LIGHT

The notable features of this are substantially the same as the Pantry Light, except that instead of a Zinc Screen there is a Cast-iron Grating fitted at the back of each Canopy, thus providing a greater measure of necessary ventilation; also the W.C. Light is pivoted to open or close.

OTHER Special Points of both above lights are

- (a) The lights are merely built in as the work proceeds, and thus the cost of fixing is reduced to the minimum.
- (b) The lights are supplied ready for fixing and no wood or other frame is required.



Internal View.

Size $13\frac{1}{2} \times 26$ in.

If fitted with Casement Stay *extra*.

Other sizes to order and prices on application.

BAXENDALE & CO. LTD.

METAL CASEMENTS

STRONG. PERMANENT. RIGID.



Give maximum Ventilation and safe cleaning facilities.
Add greatly to the appearance of any Building, and can be
made in a variety of Artistic Designs to suit any style or
period Architecture.

All Standard size Windows and French Windows
can be supplied.

Estimates on receipt of Specification.

MILLER STREET · MANCHESTER

METAL CASEMENTS

Standard Sizes

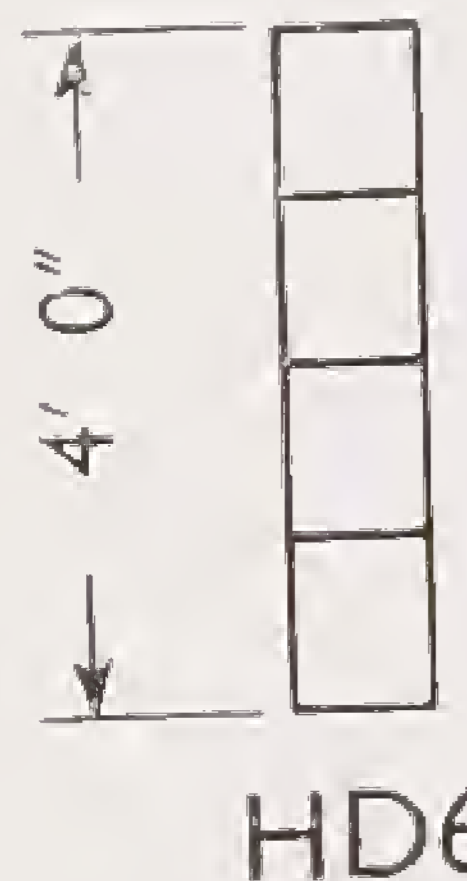
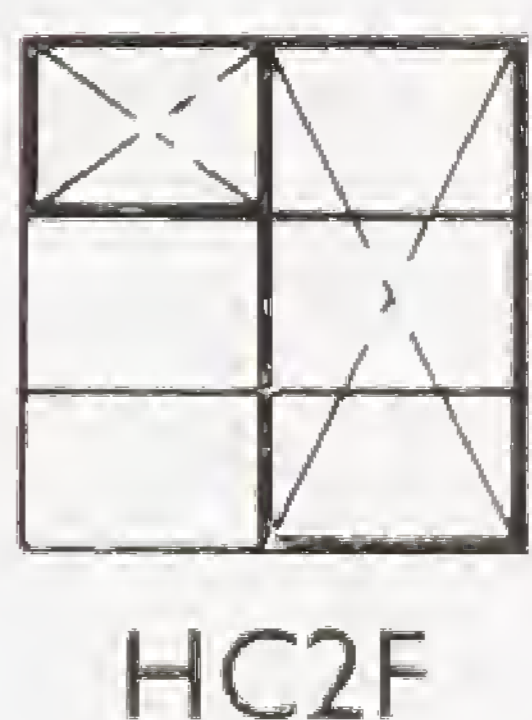
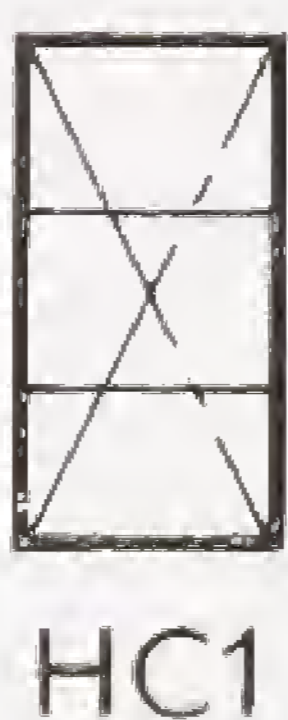
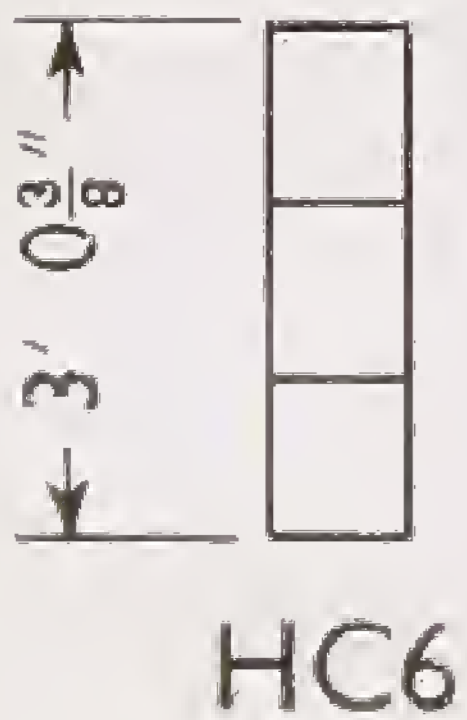
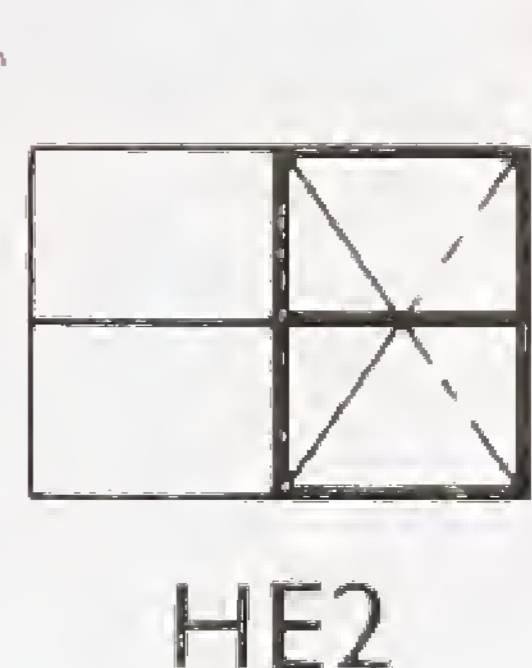
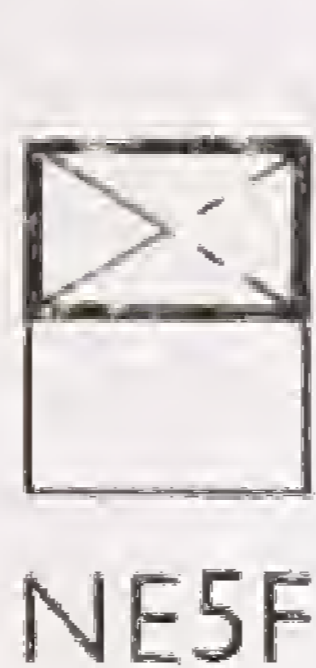
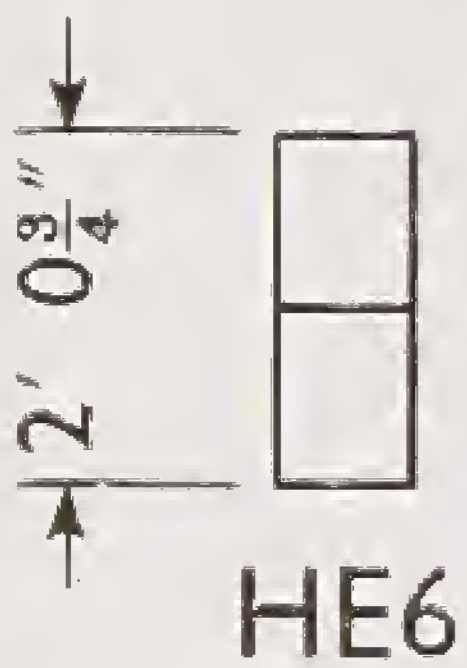
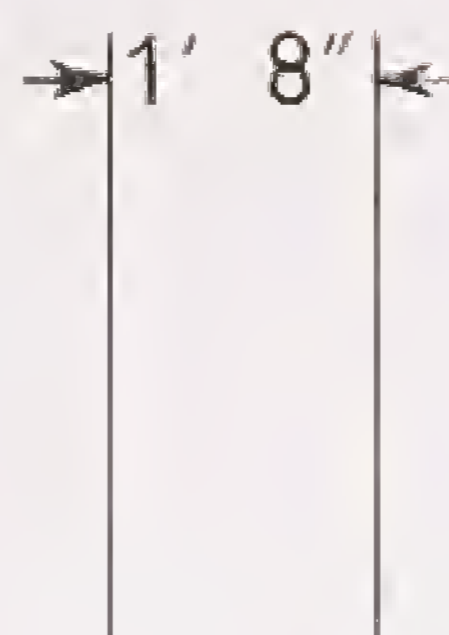
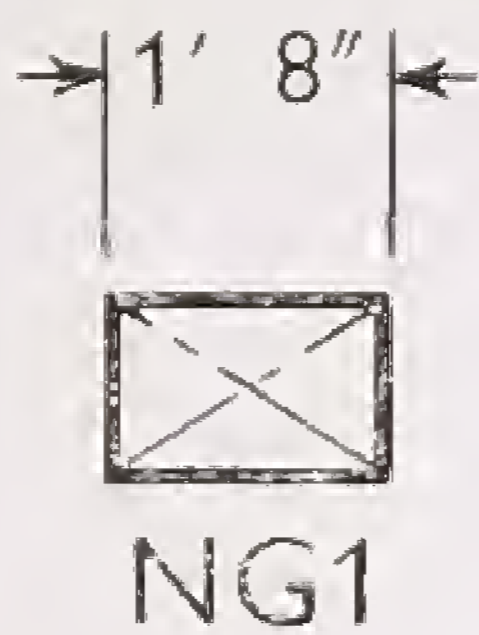
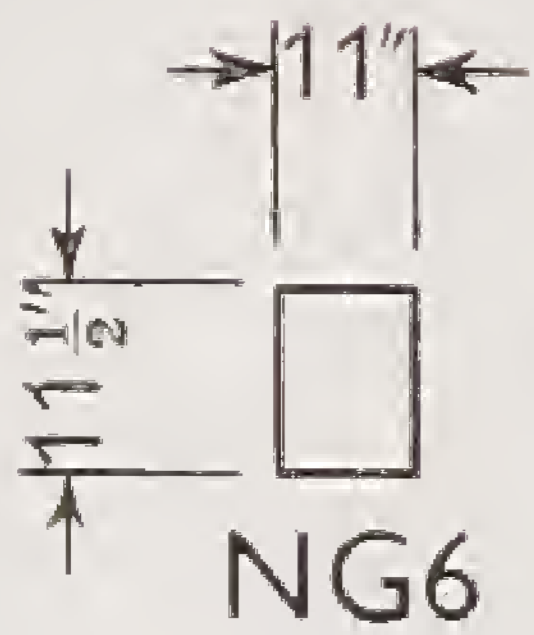

Special Sizes
made to order

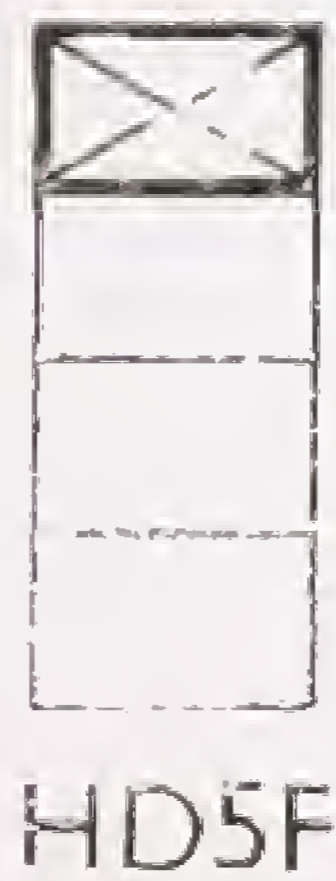

Also obtainable
from stock, sizes
4 ft. 11 3/8 in. high
in widths 6 ft.
6 1/2 in., 4 ft. 10 1/2
in. and 3 ft. 3 1/4
in.

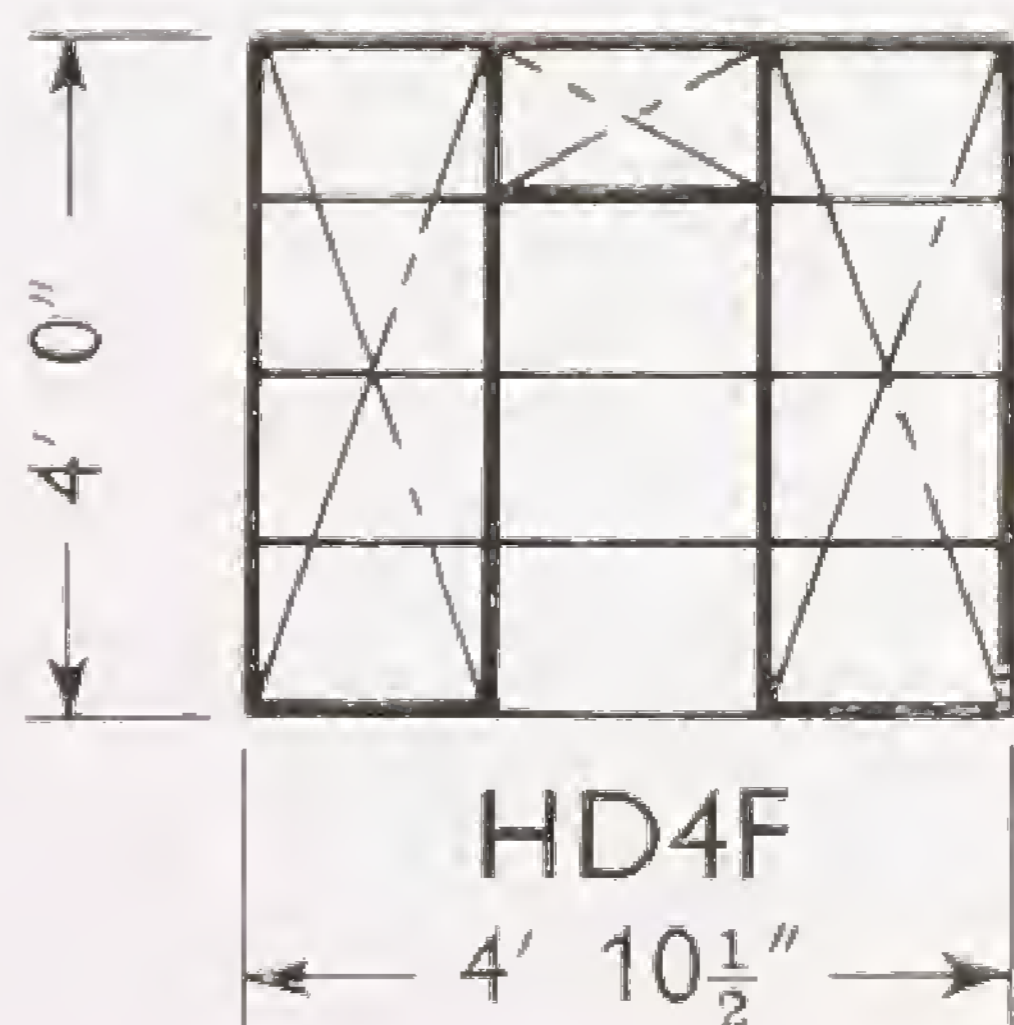
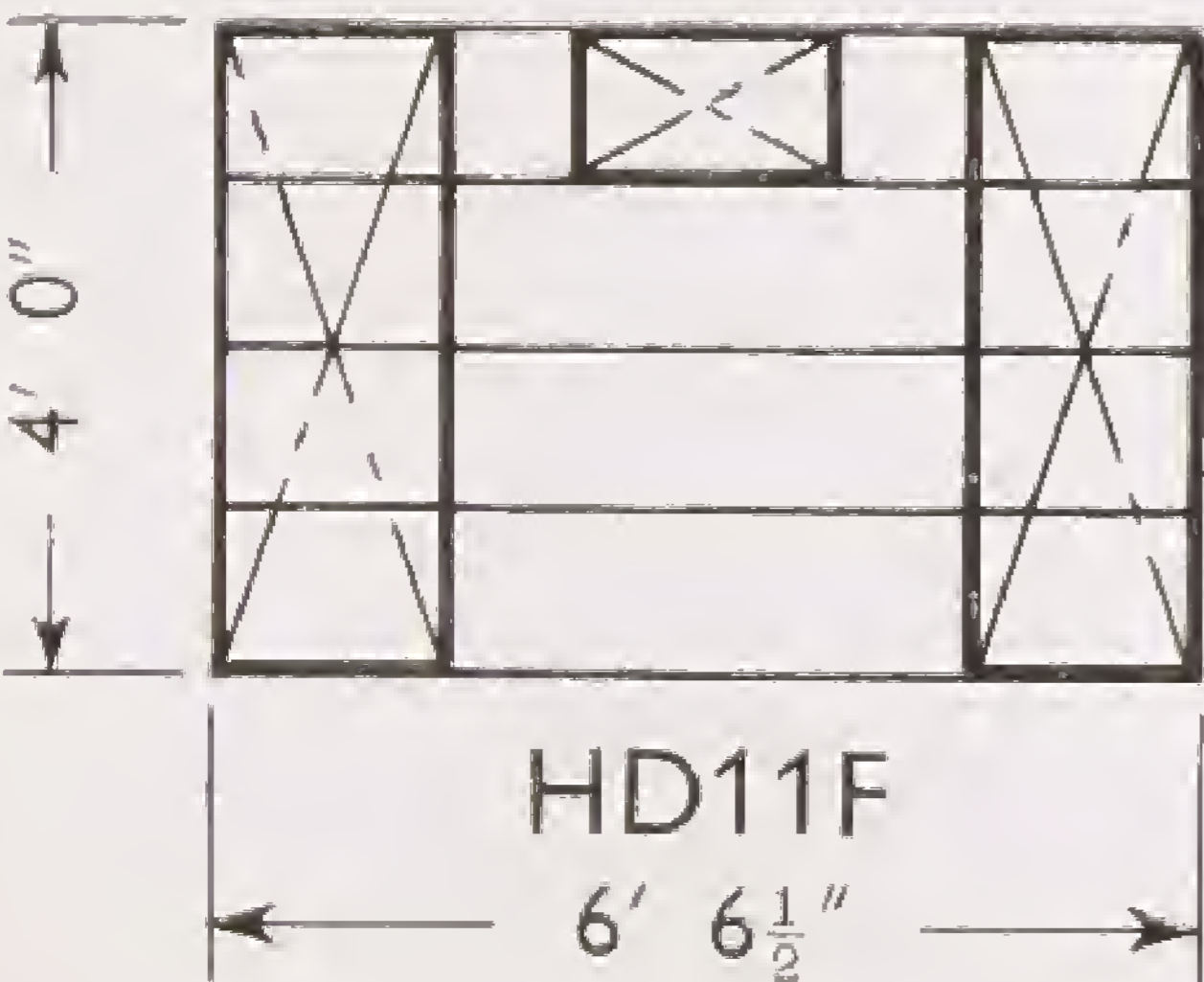

Blackintosh

REGD

FLEXIBLE

(Regd. Trade Mark)



ROOFING MATERIAL

(Made on Scientific Principles)

Is Permanent. Does Not Crack. Gives satisfaction every time under any condition when properly fixed in accordance with our instructions.

BLACKINTOSH is a special Roofing Material supplied in Rolls like ordinary felt, but superior in every way. It is made from bituminous and other substances of a permanent character, under scientific conditions which guarantee satisfactory results. It is free from tar.

SPECIAL FEATURES

BLACKINTOSH is Light. Can be bent to any curve. Is Easily Repaired. Moderate in Price. Low Maintenance Costs. Withstands Fumes. Will not Run or Melt. Outlasts Iron or Zinc. Will not harbour vermin, decay, or deteriorating elements of any kind. Is neat, clean, rustless, and attractive. It is Elastic. A non-conductor of heat, maintains an equable temperature.

PARTICULARS AND SIZES

For Flat Roofs, Sloping Roofs, Curved, Dome, or Angle Roofs; Valley Gutters, Flushings, Bay Windows, or Dormer Roofs. Also made in special forms for Flooring and Damp Course work.

Made in Three Strengths, all of which are suitable for general purposes, among which we suggest the following:—

- No. 30.—Medium strength for more substantial work; Stables, Workshops, Temporary Warehouses, etc.
- No. 40.—Strong Medium for all Permanent Jobs.
- No. 50.—Strongest and Best. Fine for best Architectural Work, Public Buildings, large Flat Roofs, Domes, etc.

BLACKINTOSH SUNDRIES

NAILS— $\frac{3}{4}$ in. Galvanized Clout Nails, $1\frac{1}{2}$ lbs. per Roll (required quantity)

CEMENT—Allow 1 pint per Roll for fixing seams.

Put up in Cans, 1 pint, 1 gallon and 5 gallon drums. Drums are Charged—returnable.

For GALVANISED CORRUGATED SHEETS see page 230.

“BEANCO”

TRADE MARK
ROOFING FELT

BEANCO ROOFING

Made in Rolls 12 yards long × 1 yard wide each containing 108 square feet, sufficient to cover 98 square feet of roof surface, and allowing 10 feet for laps.

No. 1 (Thick)

Average weight per Roll, 50 lbs. For Permanent Roofs, Engineering and Shipyard Workshops, Railway and Dock Sheds, etc.

No. 2 (Medium)

Average weight per Roll, 40 lbs. For Ordinary Buildings and Light Roofs.

No. 3 (Thin)

Average weight per Roll, 28 lbs. For Temporary Roofs, Lining Wooden and Iron Buildings, Insulating Cold Stores, Under-Slating, etc.



RUBBEROID ROOFING AND ACCESSORIES
ALSO STOCKED.

Bedale

REGD
ROOFING FELT

Known for its reliable quality. For use on poultry houses, sheds and any small buildings about the house, farm or factory. Also an excellent underslating for slates and tiles.

Rolls contain 12 square yards (108 square feet). Width 36 in. One roll covers approximately 100 square feet of roof surface. Standard (22 lb.) Heavy (30 lb.)

Prices and Sample Card on Application.

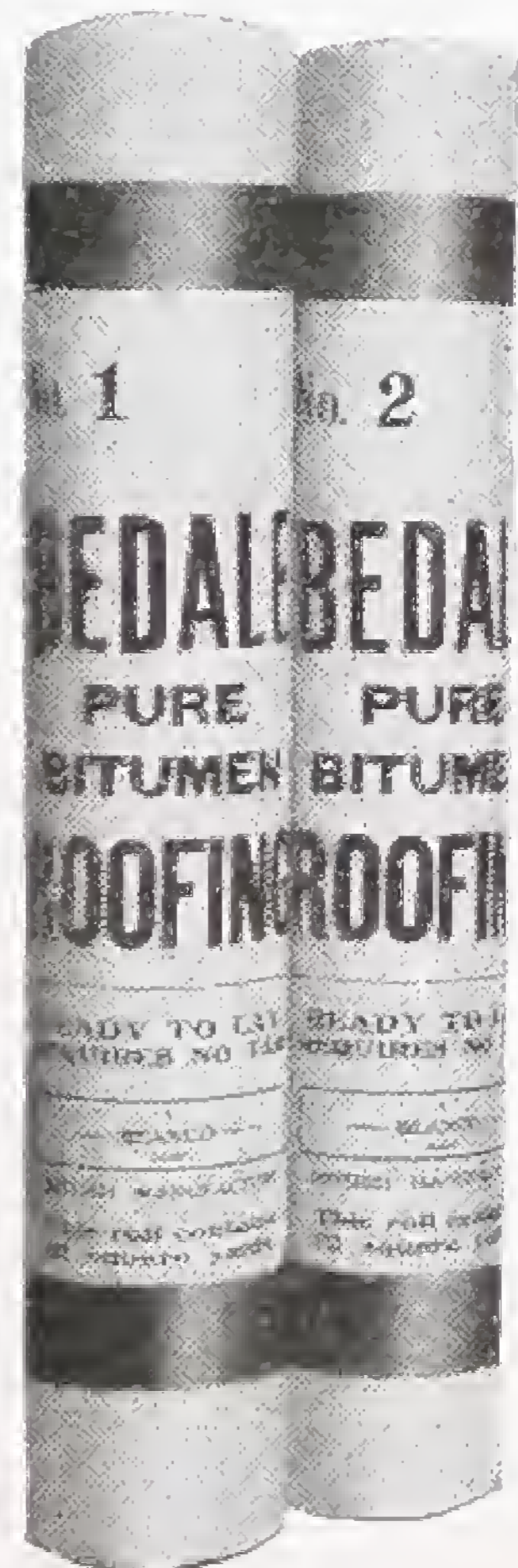

BAXENDALE & CO. LTD.

Texo

(Regd. Trade Mark)

THE ORIGINAL PLASTIC COMPOUND

FOR REPAIRING

LEAKY ROOFS

of every description.

For Making New Waterproof Roofs, and for General Repair Work.

BRITISH MANUFACTURE.

STICKS ANYWHERE.



TEXO is a black plastic compound of asbestos and plastic material, and has about the same consistency as putty.

TEXO never becomes brittle. It expands and contracts with the surface to which it is applied, and its wonderful elasticity and adhesion ensures its permanence.

TEXO makes a lasting repair. It will seal cracks and leaks, not for a month or a year, but for a lifetime.

TEXO is used by British Railways, Government Controlled Establishments, Shipyards, Collieries, Municipal Authorities, etc.

MILLER STREET · MANCHESTER

Liquitexo (Regd. Trade Mark)

Semi-Plastic Roof Preserver

FOR APPLICATION BY BRUSH

As its name implies "LIQUITEXO" is Texo in a rather more liquid form, and is an adjunct to, not a substitute for **Texo Compound**. It is made of the same materials, namely, asbestos and adhesive Gums, but is much thinner in consistency. It can be applied by means of a stiff brush, and forms a thin film all over the surface treated.

Liquitexo is a protective and preservative coating and must not be confounded with Texo Repairing Compound, nor used for the same purposes.

It is specially recommended for preserving new roofs, or where the roofing is already in a fair state of repair and requires only a preservative coating to keep it so.

Supersedes all other materials for making gable walls weatherproof.

Liquitexo will not fill up holes or cracks—Texo Compound is the right article to do that.

It is Black, can be applied to any dry surface, and sticks with the same efficiency as the Compound.

Liquitexo is always ready for use.

A Few Uses for LIQUITEXO are as follows:—As a protective covering for iron work, cement, plaster, porous brick, corrugated iron and metal roofs (especially the underside). As a dressing for felt roofs which are in fairly good order otherwise, but want reinforcing for greater weather resistance. As a primer for porous surfaces (such as concrete and similar) for Texo Compound to follow. Coating of the interior of gutters which may be in too bad a condition for ordinary painting, or as a protective coating.

COVERING POWER

Its spreading capacity varies according to the surface to which it is applied. For instance, porous or very absorbent felt will necessarily take more Liquitexo than smooth iron.

Liquitexo should be applied liberally. 20/30 feet is the area covered per lb. under the most favourable conditions and rubbed well out. It is advisable to leave it somewhat thicker than this. Under unfavourable conditions the surface treated may drop to 10 feet per lb.

Packed in:

Barrels (4 cwt. and 5 cwt.)	1 cwt. drums	1 gall. tins
Half-Barrels (2 cwt.)	$\frac{1}{2}$ cwt. "	$\frac{1}{2}$ " "
	$\frac{1}{4}$ cwt. "	

VENTILATORS

**IMPROVED
AIR EXHAUST
VENTILATORS**



No. V 1000



No. V 1001



No. V 1002

Dimensions in inches

Dia. of Pipe	6	8	10	12	14	16	18	20	22	24
Square of Base	11	16	21	26	31	36	41	46	51	56

Made of heavy sheet steel and finished in Two Coats of Best Oil Colour in Two Shades
When ordering please state size of Pipe and also size of Pipe

Roof fixed with

No. V 110

**IMPROVED DIRECT ACTING
RIDGE VENTILATOR**

Fixed to gable end ridges in two shades

Length and width
of Ventilator

18" x 24"	24" x 30"
24" x 36"	30" x 42"

Details of other part on application

Please ordering specify size pitch of roof



VENTILATING TERMINALS FOR SOIL PIPES



No. V 1025
CAST LEAD

Diam. : 2, 2½, 3, 3½, 4 in.



No. V 1024
REIGN-OUT
CAST LEAD

Shank, 3¼ in.
Diam. Top, 6¾ in.
Height, 5½ in.



No. V 1029
A.B.M.
FRESH AIR
INLET

A strong and durable air inlet made of die-cast alloy with a hooded top and a bead to facilitate caulking into the drain pipe.

It is operated by means of a flap which remains closed by gravity.

No. V 1064
ELLIOTT'S
FRESH AIR
INLET

Fine Cast-iron for
4 in. Pipe.

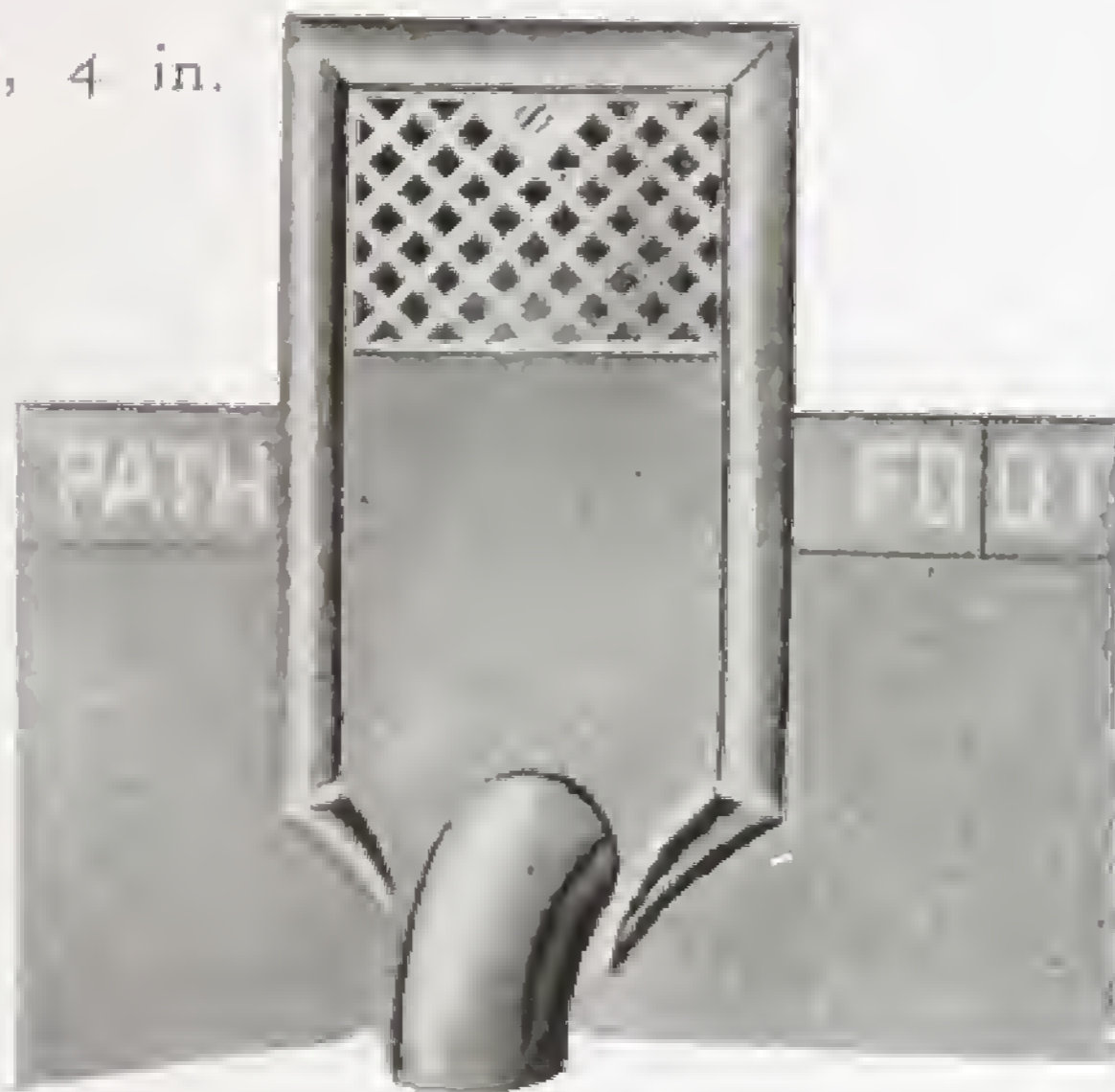

MICA-FLAP INLETS

Cast Brass Fronts
Vertical and Horizontal
for 4 and 6 in. Pipe.



No. V 1030
Vertical

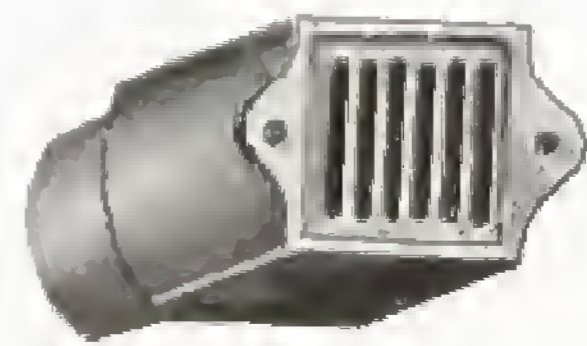

No. V 1031
Horizontal

WIRE GUARDS

Sizes 2 2½ 3 3½ 4 in.

Galvanized or Copper

Larger sizes to Order.



No. R 447

Cast-iron cowls are shown with soil pipes and connections

Heavy Cast-Iron Drain Pipes and Connections.

Quotations and line drawings will be sent on receipt of specifications.

BAXENDALE & CO. LTD.

VENTILATORS



No. IR 2091
IRON VENTILATOR

Painted

8" x 11" 10" x 14" 12" x 16" 14" x 18" 16" x 20" in.
Also supplied with Lenses to work
by Card, wire.



No. V 1049
SHERINGHAM INLET
VENTILATOR

Made in Plate Iron.

Size of Box	Size of Frame
6" x 7"	10" x 12" 10"
8" x 8"	12" x 14" 12"
10" x 10"	14" x 16" 14"
12" x 12"	16" x 18" 16"

Complete with weight and hand
pulley but without cord or wire
pulley.



No. IR 2207
BRASS HIT AND
MISS VENTILATOR

Painted Frame. Both Sides

Length	7"	8"	10"	12"
Width	4"	5"	6"	8"
Length	8"	10"	12"	14"
Width	5"	6"	8"	10"



No. IR 2208
BRASS
VENTILATOR

Painted Frame with
Thread Bit

7"	8"	10"	12"
----	----	-----	-----



No. V 1052
CAST IRON LOUVER
VENTILATOR

Box Size. Black Japanese.

8" x 8"	10" x 10"	12" x 12"
---------	-----------	-----------

10" x 10"	12" x 12"	14" x 14"
-----------	-----------	-----------

Complete with wire Pulley and
Case & Wood Screw Handlet wire



No. V 1044
LOUVER AIR GRID

Painted

8" x 8"	10" x 10"	12" x 12"	14" x 14"
---------	-----------	-----------	-----------

Painted or Galvanized

AIR GRIDS



No. V 1043 AIR GRID

Fine Mesh. Black painted.

8" x 8"	10" x 10"	12" x 12"	14" x 14"
---------	-----------	-----------	-----------

Black painted



No. V 1044 SLIDING AIR GRID

Fine Mesh. Black painted.

8" x 8"	10" x 10"	12" x 12"	14" x 14"
---------	-----------	-----------	-----------

No. V 1053

Light pattern, similar to above

8" x 8"	10" x 10"
---------	-----------

COWLS, CHIMNEY TOPS, Etc.

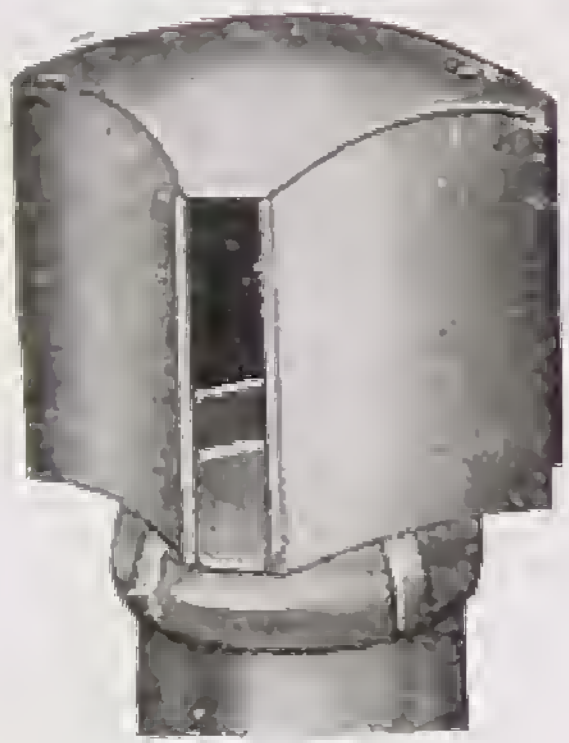

No. V 1053

COLT CHIMNEY COWL

18s G. B.B.3
Birmabright.
Aluminium Alloy.
Sizes 4 in. and upwards.



No. V 1041

LOBSTER-BACK COWL

Galvanized Steel.
Square Base and
Without Base.

Sizes :

6, 8, 9, 10 and 12 in.

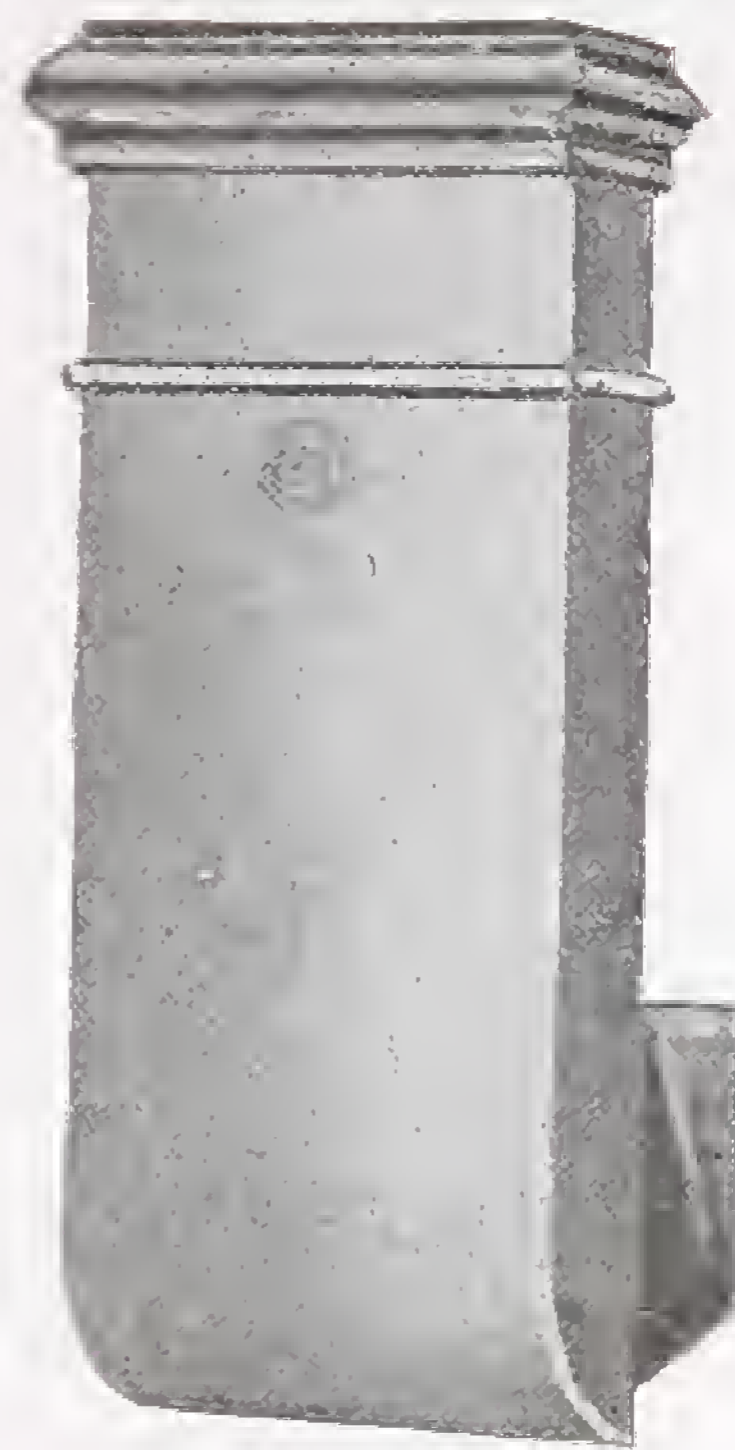

No. V 1060.

AIR INLET VENTILATOR

Improved Flat
Vertical Tube, Moulded
Top
Valve and
Brass Fist Handle.
9 x 4 in., without Panel—

Length (inches)

12	18	24	30
36	42	48 in.	



No. V 1039

REVOLVING CHIMNEY COWL

Strong Galvanized Steel;
Ball Bearings; Oil Cup.
To Fit—
4 5 6 7 8 9
10 and 11-in. pots

No. V 1015

ARCHIMEDEAN SCREW VENTILATOR. Round Base

-	-	6	8	9	10	11	in. dia.
12	14	16	18	20	22	24	in. dia.

No. V 1016

ARCHIMEDEAN SCREW VENTILATOR. Square Base

Dia. of pipes...	6	8	9	10	11	12	in.
Size of base...	8	10	11	12	13	14	"
Dia. of pipes...	14	16	18	20	22	24	in.
Size of base ...	16	18	20	22	24	26	"



FIRECLAY CHIMNEY POTS
For Preventing Down-draught.



No. 254 001
THE BASHINGALE
In Brown Salt Glazed
Red and Buff
4 in. dia. at top & bottom
of a cone
2 ft. 2 in. high



No. 254 001
THE LAYE
In Brown Salt Glazed
Red and Buff
Height 20 in.



No. 254 001
THE CLAMPFORD
In Brown Salt Glazed
Red and Buff
4 ft. 6 in. high



No. 254 001 **THE STANLEY**
In Brown Salt Glazed
Red and Buff

Height	Base diameter	Top diameter
21 in.	4 1/2 in.	6 1/2 in.
24 in.	4 1/2 in.	6 1/2 in.
27 in.	4 1/2 in.	6 1/2 in.

*Lattice pattern the same in each height

OLD BUSINESS MATERIALS DEPT.

Large Stock of Glazed Britannia Drain Pipes and Connections
Lead, Sand, Cement
Flue Tiles, Barley Stems and Tiles
Wallpaper, Papered Metal and Lathing
Asbestos Cement Slates and Battens
Slate Cans for Covering, etc. Unpapered Cement
Laminated Glass Slates. Air Bricks & C.
Lead Clime (Ingotment). Wall Tin Metal

STONEWARE DRAIN PIPES AND FITTINGS

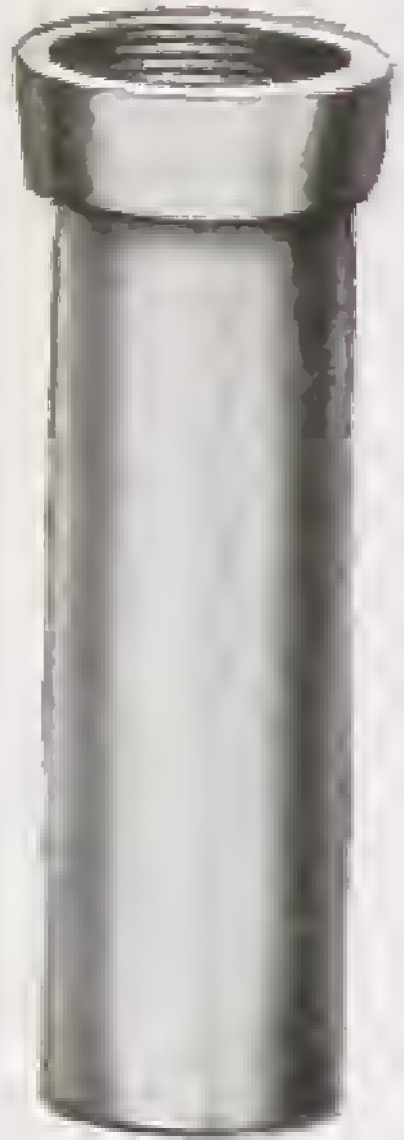

Glazed Circular Pipe



Double Junction.



Junction



Access Pipe
with or without
lid.



P Trap



S Trap

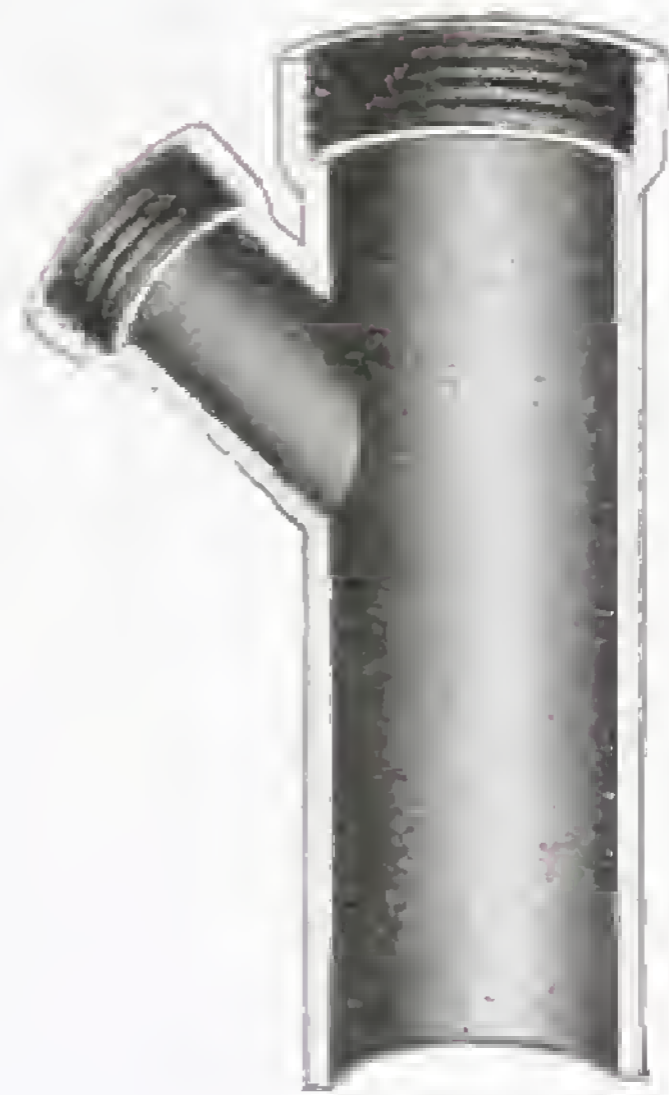

Half
Junction



Yard Gulley Trap



Dish with Cast
Iron Grating



Yard Gulley Trap

Special quotations for quantities.

**UNBREAKABLE STEEL GROUND
MANHOLE COVERS
SINGLE SEAL**

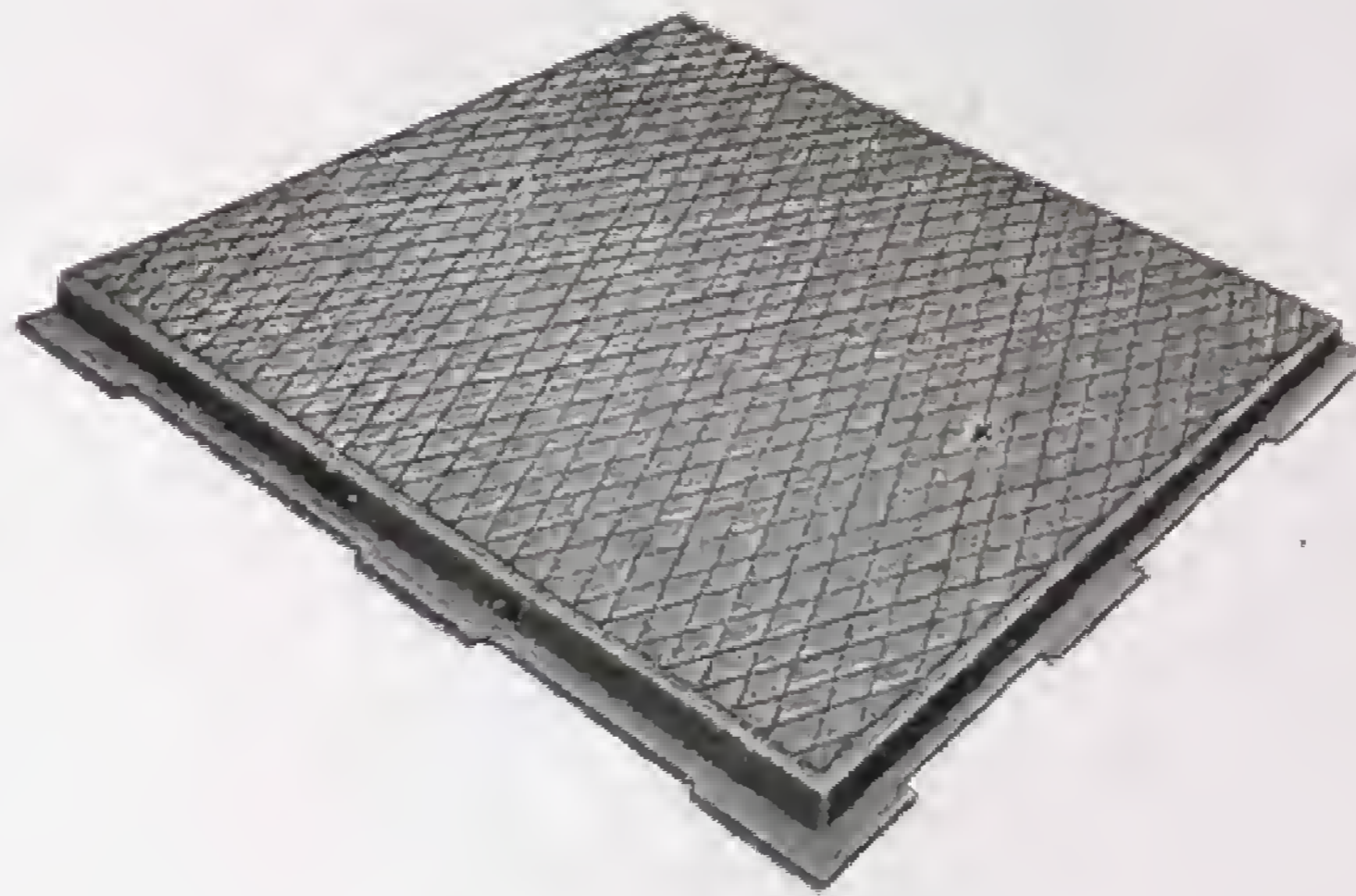

Safe Load ;
Light
Pattern,
5-Ton Lorry.

Safe Load ;
Heavy
Pattern.
10-ton, 4 Wheeler
15 " 6 "

No. H 1110

MILD STEEL COVER

Manhole Covers and Frames have so far been made in Cast Iron only—heavy to handle and easily broken. The "Unbreakable" Cover consists of a steel plate with chequer surface (non-slip). The Frame may be of Cast Iron or of unbreakable Welded Steel. The Cover fits flush with the top of the frame, has 2 Keyholes for Lifting Keys, and may have locks fitted. A special Key is supplied when Locking Gear is fitted. When the Key is turned through 90 degrees the Cover is unlocked and may be lifted with the Key. When replaced it is impossible to remove the Key without first locking the Cover in place. May be supplied with Handgrip instead of Key Lift. Broken C.I. Covers may be replaced by our Unbreakable Steel Cover to fit Existing Frames.

Daylight Sizes	Approximate Weights			Daylight Sizes	Approximate Weights		
	Cover Only	Frame			Cover Only	Frame	
in.	c. qr. lb.	qr. lb.	qr. lb.	in.	c. qr. lb.	qr. lb.	qr. lb.
12 x 12, Light Heavy	0 0 21 0 0 25	} 0 14	0 14	*24 x 24, Light Heavy	0 2 5 0 2 17	} 1 0	1 3
15 x 15, Light Heavy	0 0 24 0 1 1		0 19	0 19	27 x 21, Light Heavy		0 2 5 0 2 17
*18 x 18, Light Heavy	0 1 10 0 1 16	} 0 23	0 23	*30 x 24, Light Heavy	0 2 25 0 3 12	} 1 17	1 7
21 x 21, Light Heavy	0 1 19 0 1 26		0 24	0 24	36 x 24, Light Heavy		0 3 21 1 0 0
*24 x 18, Light Heavy	0 1 21 0 2 2	} 0 27	0 27	*30 x 30, Light Heavy	0 3 24 1 0 4	} 1 26	1 11

* These Sizes in Heavy Pattern always in Stock for immediate delivery.

Double Seal Covers and Locking Gear, All Sizes.

Hinged Covers supplied with steel frames only.

BAXENDALE & CO. LTD.

INSPECTION OR MANHOLE COVERS AND FRAMES



No. H 1109

Sizes Inside In.	Approx. Weight			Sizes Inside In.	Approx. Weight			Sizes Inside In.	Approx. Weight		
	C.	Q.	Lb.		C.	Q.	Lb.		C.	Q.	Lb.
9 x 9	0	0	19	20 x 18	0	3	7	24 x 24	*1	0	0
									1	1	0
12 x 12	0	1	0	24 x 12	0	2	10		1	2	0
	0	1	14		0	3	7		2	0	0
15 x 15	0	1	14	20 x 20	0	2	2				
	0	1	24		0	3	2	30 x 24	1	1	0
18 x 12	0	1	11	24 x 18	*0	2	0		1	2	0
	0	2	11		*0	3	0		2	0	0
					*1	0	0				
18 x 14	0	2	18		1	2	0	36 x 24	1	2	21
					1	3	0		2	0	0
					2	0	0		3	0	0
18 x 18	*0	2	0		4	0	0				
	0	3	0								
	*1	0	0	30 x 18	1	0	0				
					1	1	7				

*Most regular sizes always in stock.

Can be supplied Keyhole Pattern if required.

Not suitable for Traffic.

BAXENDALE & CO. LTD.

WATER METER and MANHOLE COVERS AND FRAMES

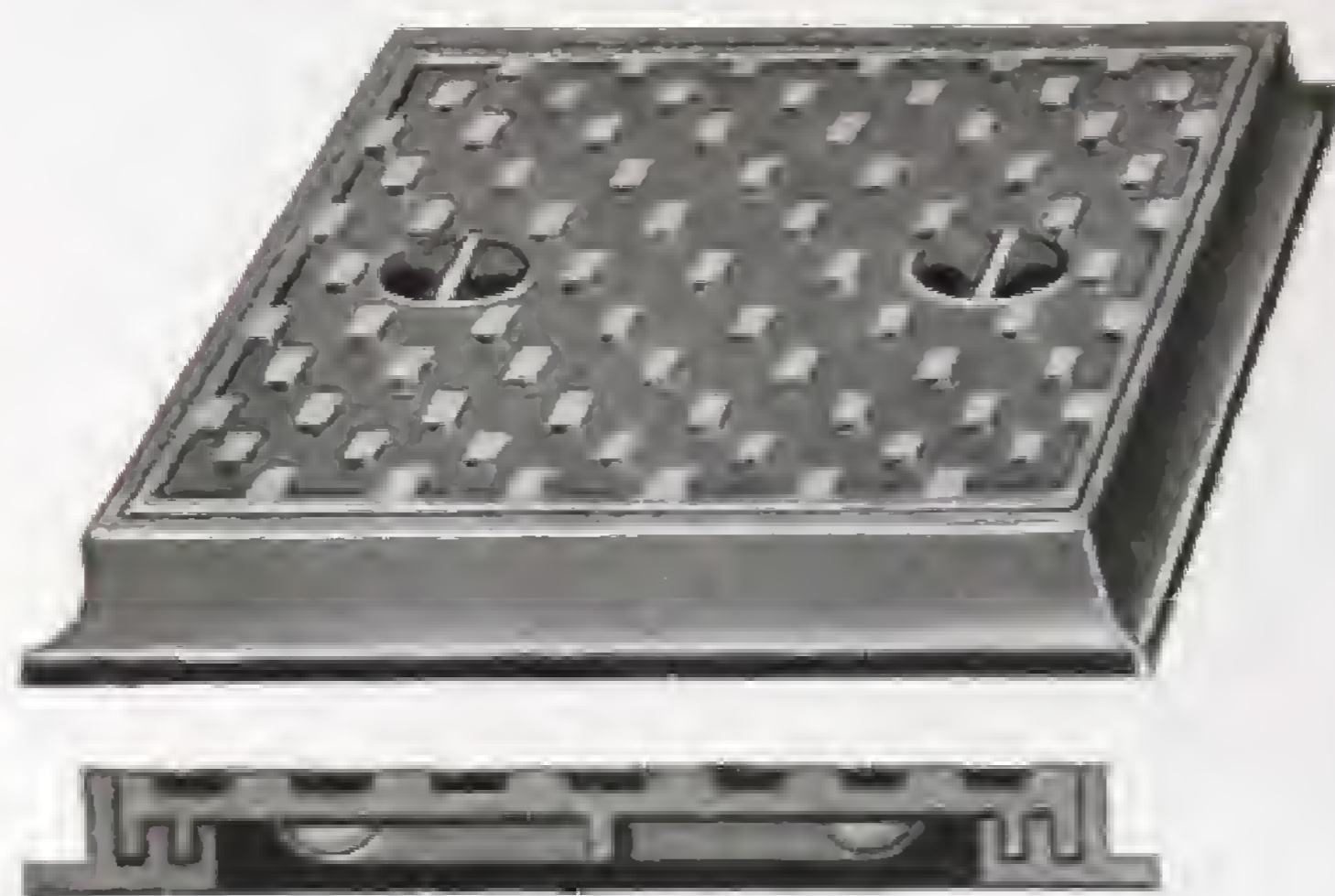

No. H 1019
MANHOLE COVER AND
FRAME

With Double Groove.

Sizes Inside in.		...	Approx. Weights			
			cwt.	qrs.	lbs.	
6	×	6	...	0	1	0
9	×	9	...	0	1	14
12	×	12	...	0	2	0
15	×	15	...	0	2	16
20	×	15	...	0	2	16
18	✓	18	...	0	3	5
24	×	18	...	0	3	26
24	×	24	...	1	1	0
30	×	24	...	1	1	12
36	×	24	...	1	2	21

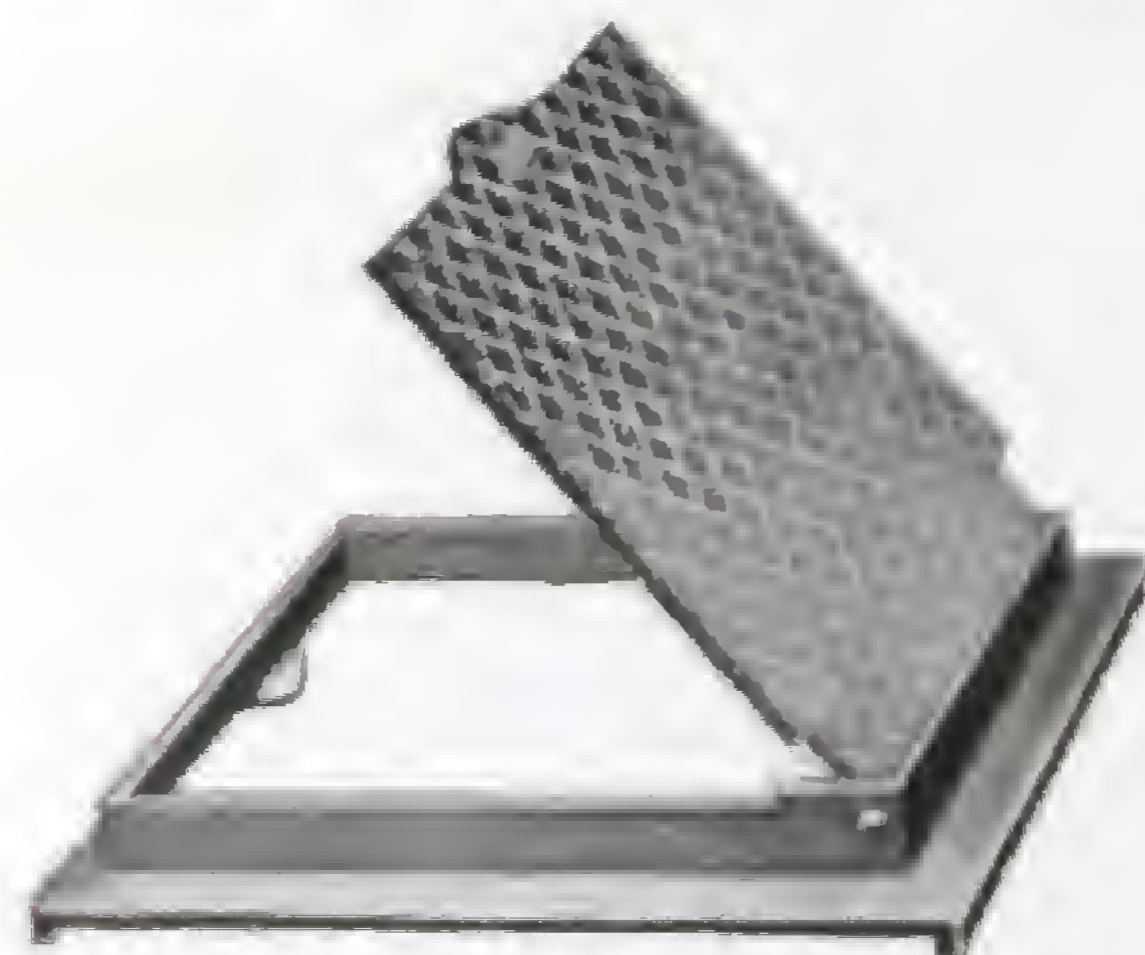

No. H 1014
WATER METER COVER

Fitted with Hinge and Brass Screw
Lock.

Sizes Outside in.		...	Approx. Weights			
			cwt.	qrs.	lbs.	
16	×	9	...	0	0	27
16	×	11	...	0	1	4
17½	×	10½	...	0	1	7
18	×	14	...	0	1	14

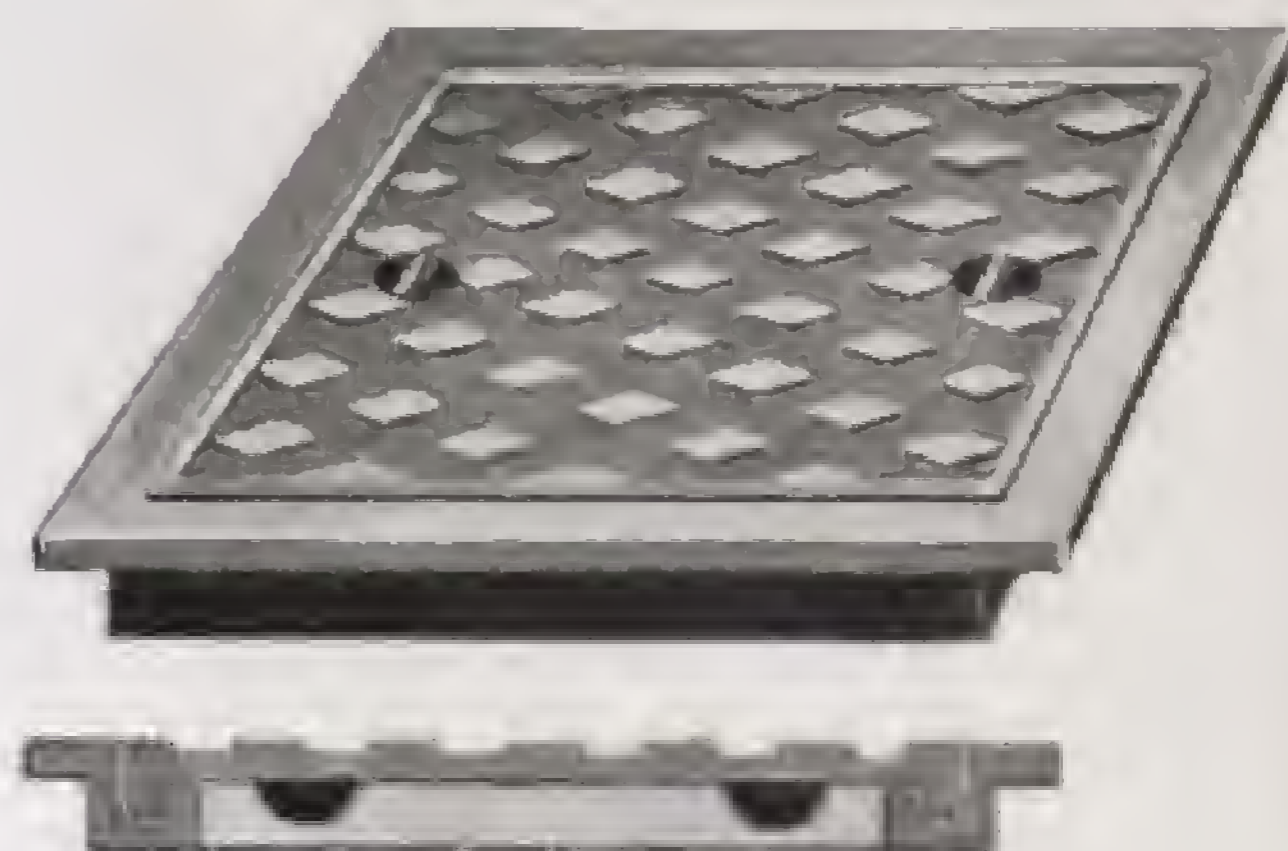

No. H 1026
MANHOLE COVER AND FRAME

Sizes Inside in.		...	Approx. Weights			
			cwt.	qrs.	lbs.	
15	×	15	...	0	2	11
18	×	18	...	0	3	7
24	×	18	...	1	0	0
24	×	24	...	1	1	7
30	×	18	...	1	1	7
30	×	24	...	1	2	14

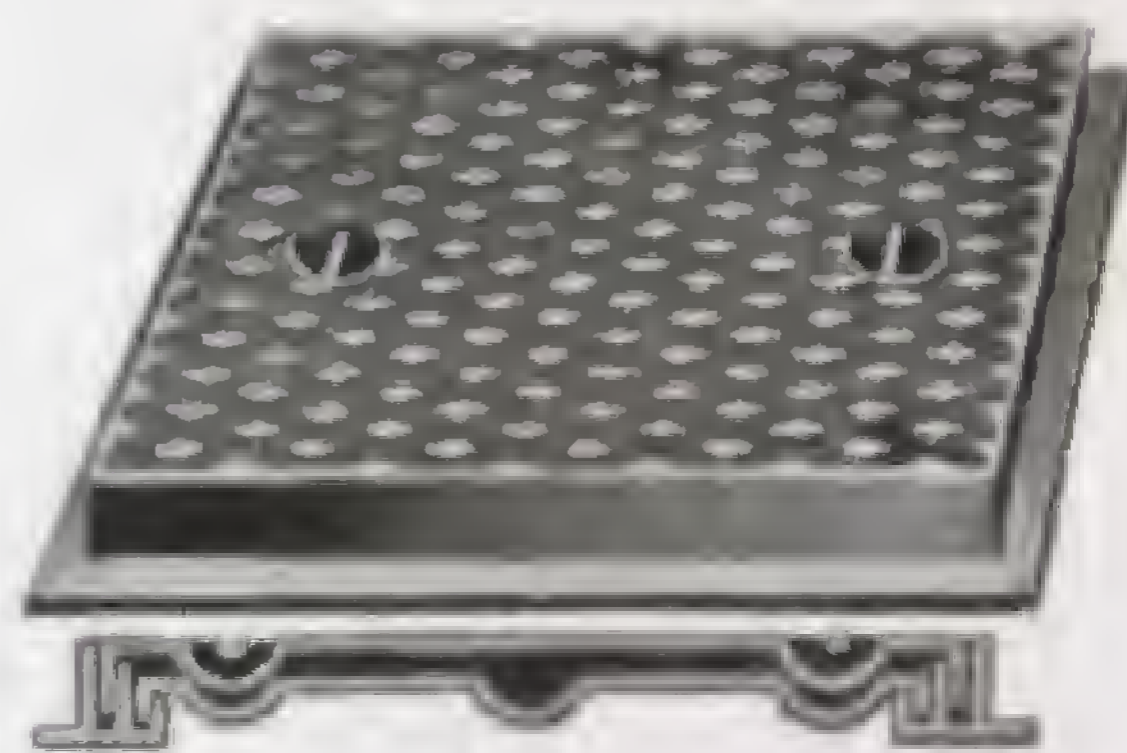

No. H 1018
MANHOLE COVER AND
FRAME

With Inner Cover and
Double Groove.

Sizes Inside in.		...	Approx. Weights			
			cwt.	qrs.	lbs.	
15	×	15	...	1	0	14
18	×	18	...	1	0	24
24	×	18	...	1	2	0
24	×	24	...	1	3	4
30	×	24	...	2	0	14

BAXENDALE & CO. LTD.

MANHOLE COVERS AND FRAMES

No. H 1028 MANHOLE COVER & FRAME With Hinge and Lock.

Sizes Inside in.	Approx. Weights cwts. qrs. lb.
18 x 18	1 0 2
20 x 20	1 0 14
24 x 18	1 0 20
24 x 24	1 1 13
30 x 18	1 1 13
30 x 30	2 0 17
30 x 24	1 3 0
36 x 24	2 0 17
36 x 30	2 2 14

H 1028 LIGHT PATTERN

Sizes Inside in.	Approx. Weights qrs. lb.
18 x 18	3 0
24 x 18	3 14

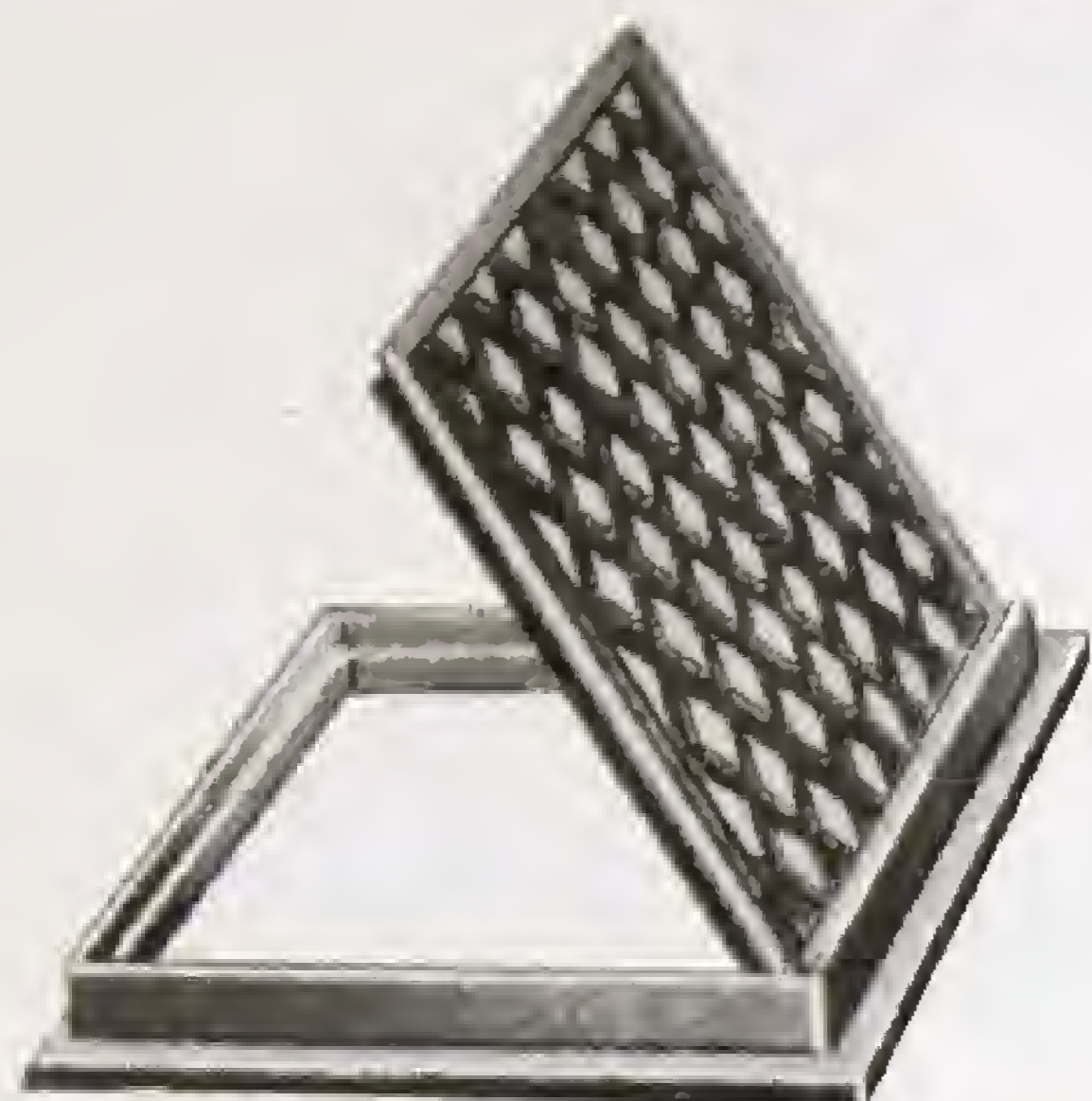

No. H 1029 (above) MANHOLE COVER & FRAME With Hinge and Lock. Extra Heavy.

Sizes Inside in.	Approx. Weights cwts. qrs. lb.
24 x 18	2 1 0
24 x 24	2 2 14
30 x 18	2 2 0
30 x 24	2 3 21

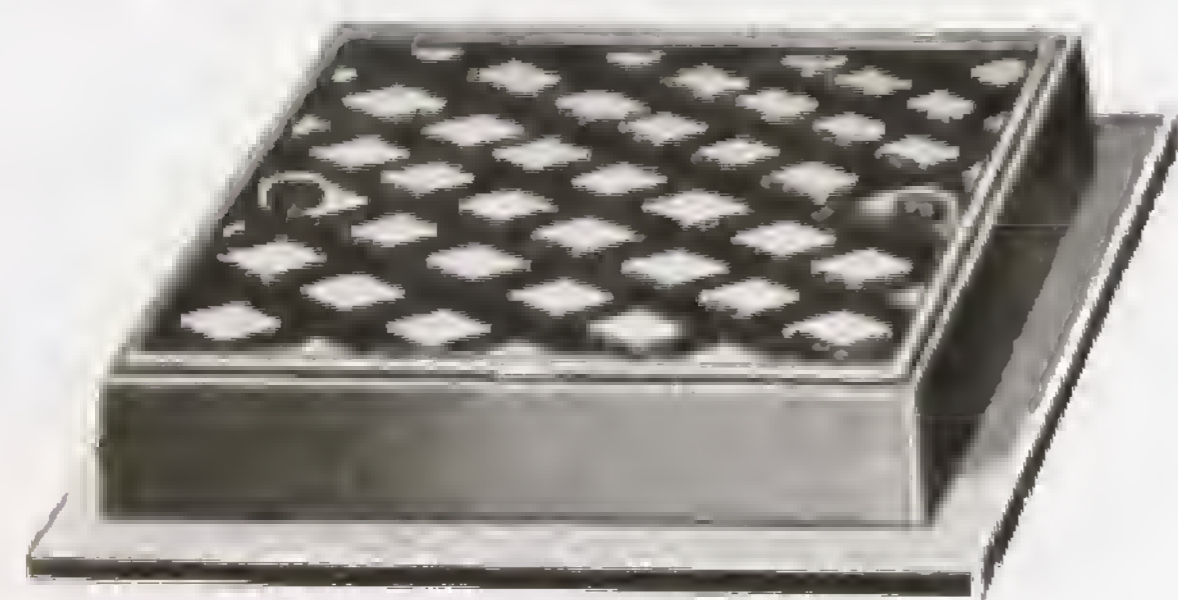

No. H 1031. AIR-TIGHT MANHOLE COVER & FRAME With India-rubber Joints and Fitted with Two Screw Locks.

Sizes Inside in.	Sizes Outside in.	Approx. Weights cwts. qrs. lb.
13 1/2 x 11 1/2	16 14	0 2 0
21 1/2 x 15 1/2	24 18	1 0 0
27 1/2 x 21 1/2	30 24	1 1 20
30 x 18	34 22	2 2 7

No. H 1031. Manholes fitted with
Gun Metal Locks. *extra.*



Manholes
fitted with
Gun Metal
Locks.
Extra.



No. H 1030. AIR-TIGHT MANHOLE COVER & FRAME With India-rubber Joint and fitted with Lock and Hinge.

Sizes Inside in.	Sizes Outside in.	Approx. Weights cwts. qrs. lb.
11 1/2 x 10 1/2	16 14	0 2 0
18 1/2 x 15 1/2	24 18	1 0 0
24 x 18	29 1/2 x 20 1/2	1 1 14
24 1/2 x 21 1/2	30 24	1 1 20

No. H 1027 MANHOLE COVER & FRAME

With Cover 1-in. deep for Concrete
Sizes Inside

Sizes Inside in.	Approx. Weights cwts. qrs. lb.
18 x 18	1 0 7
24 x 18	1 1 7
24 x 24	1 2 14
30 x 24	1 3 2
30 x 30	2 1 2

H 1027 LIGHT PATTERN

Sizes Inside in.	Approx. Weights cwts. qrs. lb.
18 x 18	0 3 7
24 x 18	1 0 0

MANHOLE COVERS AND FRAMES

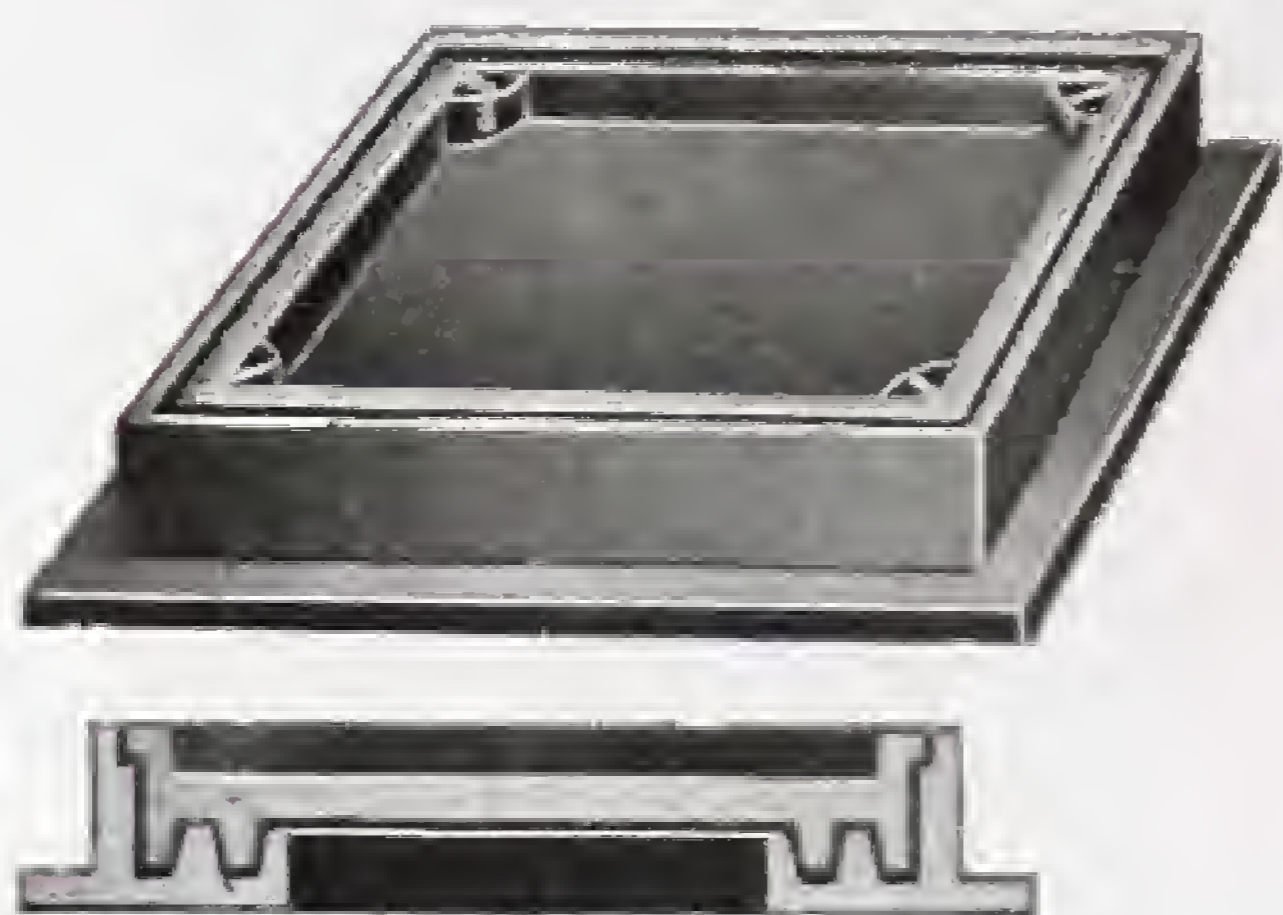

No. H 1012

DOUBLE SEAL MANHOLE COVERS AND FRAMES

With 2-in. Deep Sunk Cover.

Sizes Inside			Weights		
in.			cwts.	qrs.	lb.
18	×	18	...	1	3 0
24	×	18	...	2	1 12
24	×	24	...	2	2 12
30	×	24	...	2	3 17
36	×	24	...	3	1 11



No. H 1033M

NON-ROCKING MANHOLE COVER AND FRAME

Manchester Pattern.

Sizes Clear			Approx. Weight		
Opening In.	Base In.	Depth In.	cwts.		
18	18	27½	24½	6½	4½



No. H 1107

NON-ROCKING MANHOLE COVER AND FRAME

Heavy Street Pattern.

Sizes Clear			Approx. Weight
Opening In.	Base In.	Depth In.	cwts.
20 dia.	28½ × 28½	7	4½



No. H 1108

NON-ROCKING MANHOLE COVER AND FRAME

Heavy Street Pattern.

Sizes Clear			Approx. Weight
Opening In.	Base In.	Depth In.	cwts.
20 dia.	27 × 27	6½	5

MANHOLE STEPS



No. H 1043

MALLEABLE IRON

Light Pattern.

Approx. Weight 2 lb. 8 oz. each.
Galvanized.



No. H 1042

MALLEABLE IRON

Heavy Pattern.

Approx. Weight 4 lb. 12 oz. each.
Galvanized.

STREET GRIDS AND FRAMES



No. H 1086
**NON-ROCKING STREET
 GULLEY GRID WITH CHUTE**
 Moss Side Pattern.

To pass MANCHESTER.

Surface In.	Sizes :		Approx. Weight		
	Base In.	Depth In.	C.	Q.	L.
19½ × 13¾	24 × 16	6½	2	0	0

No. H 1083
 To pass SALE, STRETFORD, or URMSTON.

In.	In.	In.	C.	Q.	L.
18½ × 12½	24 × 15½	6	1	2	14

No. H 1084
PASSAGE GULLEY GRID
 Manchester Pattern.

In.	In.	In.	C.	Q.	L.
16½ × 11½	21 × 13½	6½	1	2	0

No. H 1075
**STRONG HINGED
 STREET GRID AND FRAME**

Surface In.	Sizes :		Approx. Weight		
	Depth In.		C.	Q.	L.
22 × 16	6		2	0	12

Flanged on 3 sides.

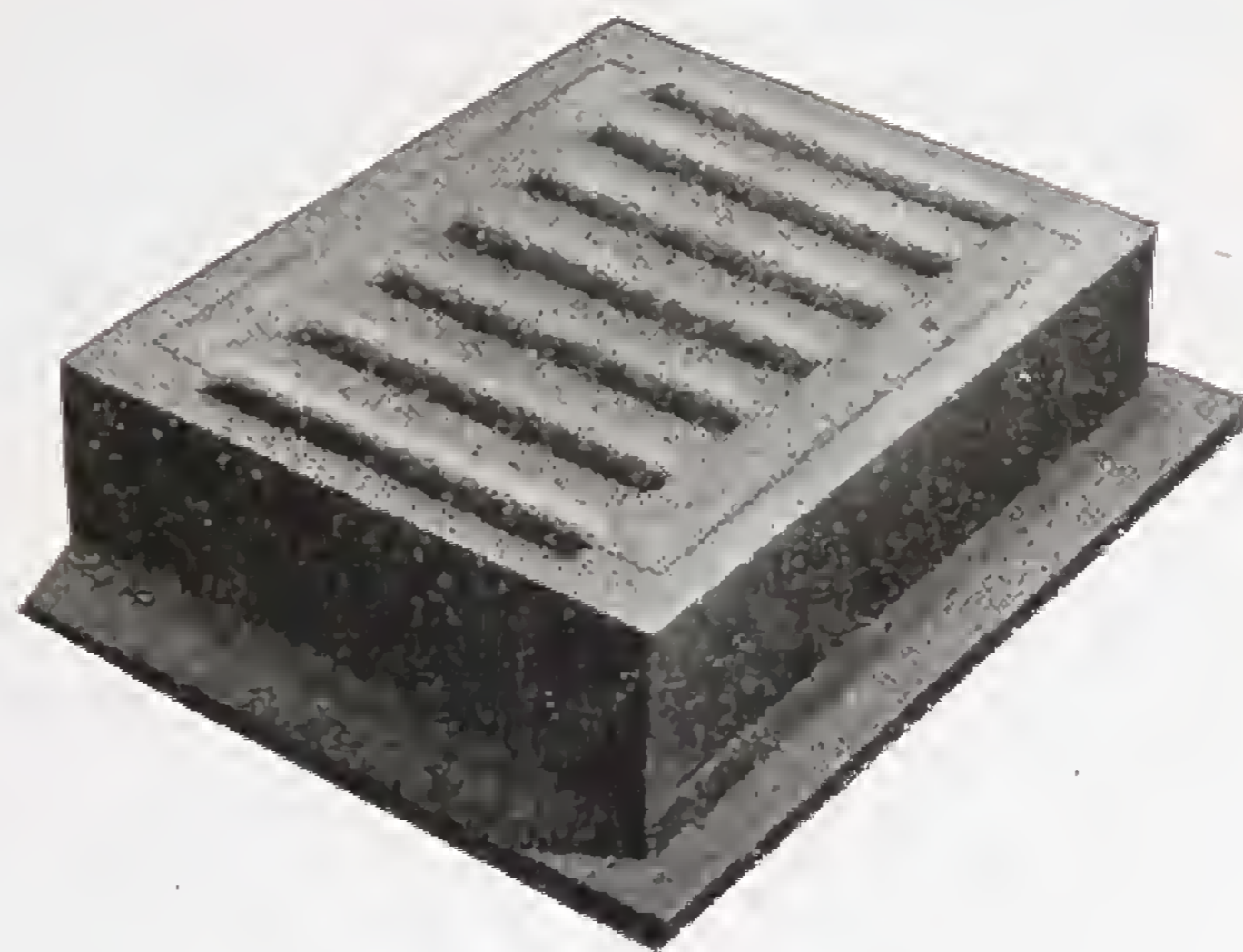
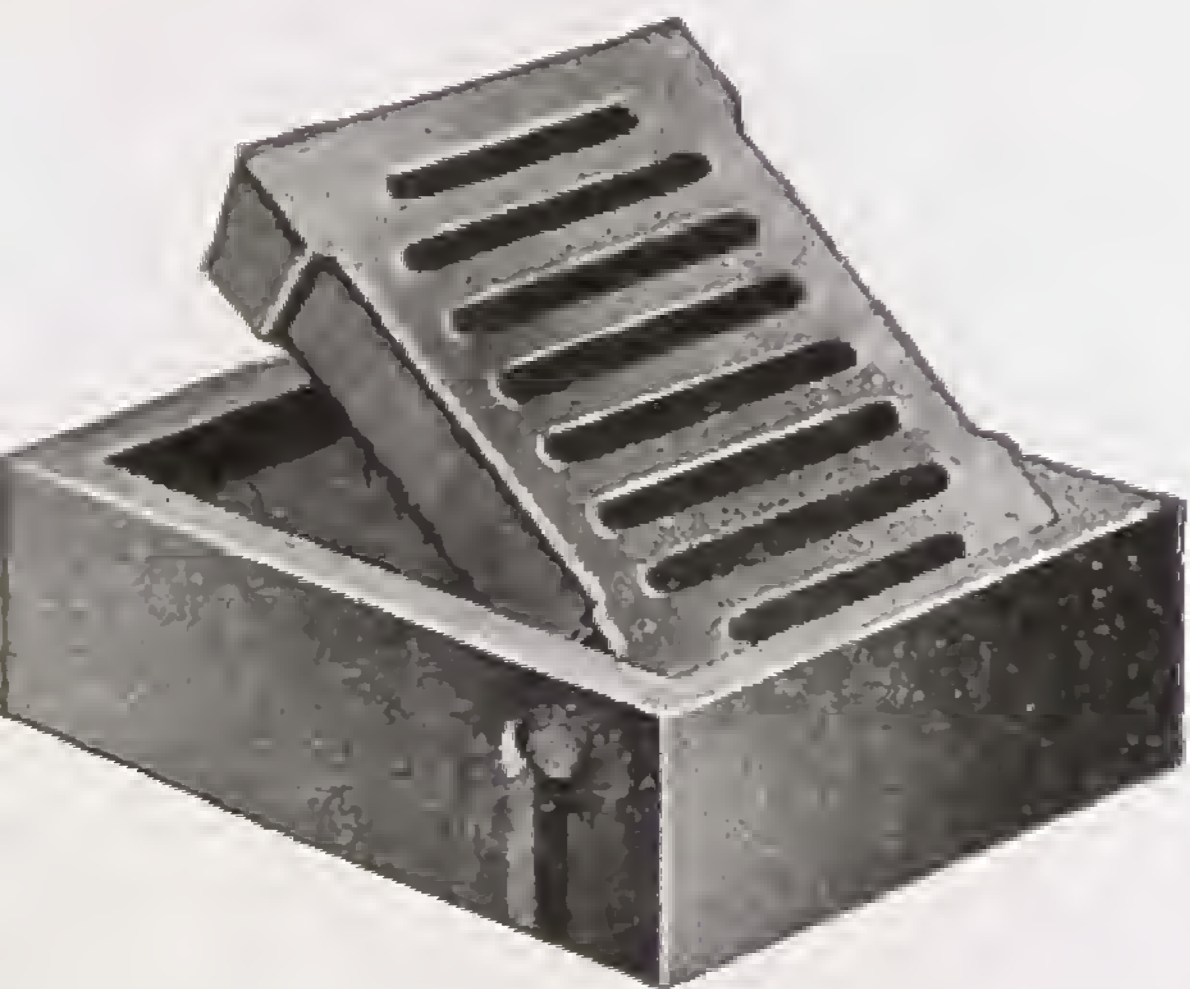

No. H 1074
**NON-ROCKING HINGED
 STREET GULLEY GRID**
 Salford Pattern.

Surface In.	Sizes :		Approx. Weight		
	Base In.	Depth In.	C.	Q.	L.
20 × 16	24 × 18	6	2	1	14

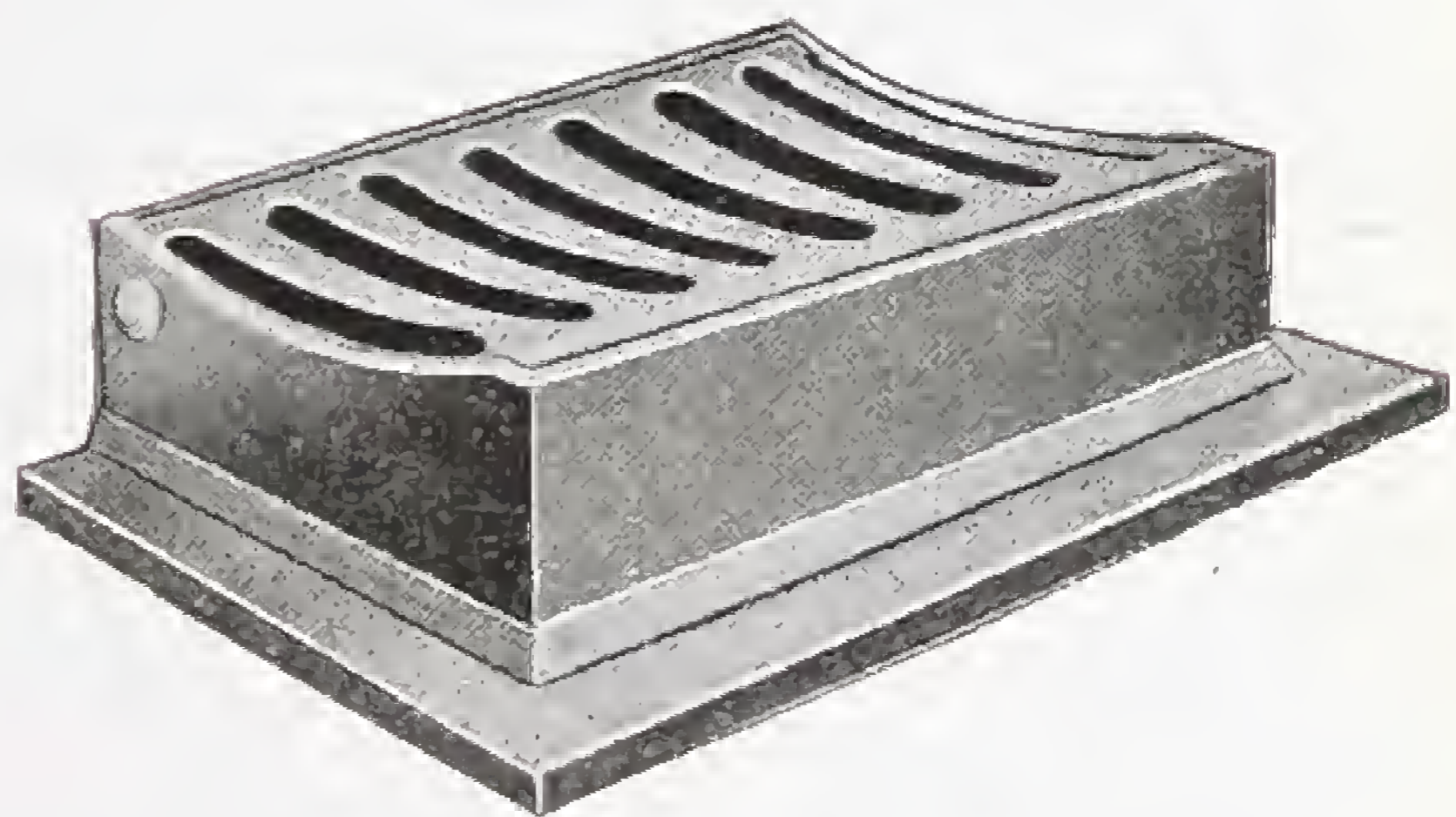

No. H 1035
PASSAGE GRID
 Manchester Pattern.

Size 12 in. × 10 in. for 14-in. Block.
 Approximate Weight, 2 qrs. 0 lb.

No. H 1036
 Size, 13 in. × 13 in. for 17-in. Block.
 Approximate Weight, 1 cwt.

BAXENDALE & CO. LTD.

GRIDS, GRATES AND FRAMES, Etc.



No. H 1039
SQUARE BOX GRIDS,
LOOSE TOPS

Sizes...	6	7 in.
Approx. Weight	9	9 lb.

No. H 1040

SQUARE BOX GRIDS,
HINGED TOPS, DISHED

Sizes	6	7	8	9	10	12 in.
Approx. Wt.	9	10½	12½	18½	21	39 lb.



No. BM 106
ROUND DISHED
GULLEY GRIDS
Sizes : 4 to 12 in. dia.

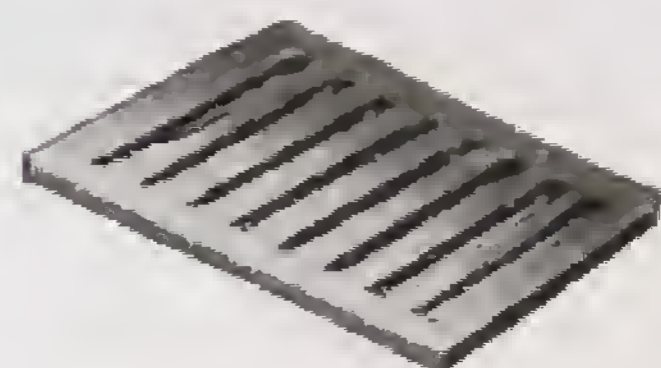

No. BM 107
SQUARE GULLEY GRIDS
Sizes 4 to 12 in. sq.



No. H 1056 No. H 1057
GARDEN GRATES & FRAMES
DISHED OR FLAT

Sizes : 5, 6, 7 and 8 in.



No. H 1082
HINGED GULLEY GRIDS
With Brass Turnbuckle and Key.

Opening	5×5	7½×7½	11×11 in.
Overall	6×6	8¾×8¾	12¼×12¼ "
Depth	1½	1½	1½ "

With or Without Brass Turnbuckle and Key.

IMPROVED SELF-LOCKING COAL PLATES



No. H 1093.
Solid.



No. H 1094.
Ventilating.



No. H 1095.
Illuminating.



No. H 1096.
Illuminating and
Ventilating.

When ordering please state if ring is for Stone or Asphalt,
Sizes : 12 to 18 in. diam.

STOP TAP BOXES



No. L 381
MANCHESTER
7½ × 6 × 3½ in. deep.
9½ × 7½ in. outside flange.



No. L 390
For Heavy Traffic.
4½ × 4½ × 4 in. deep.

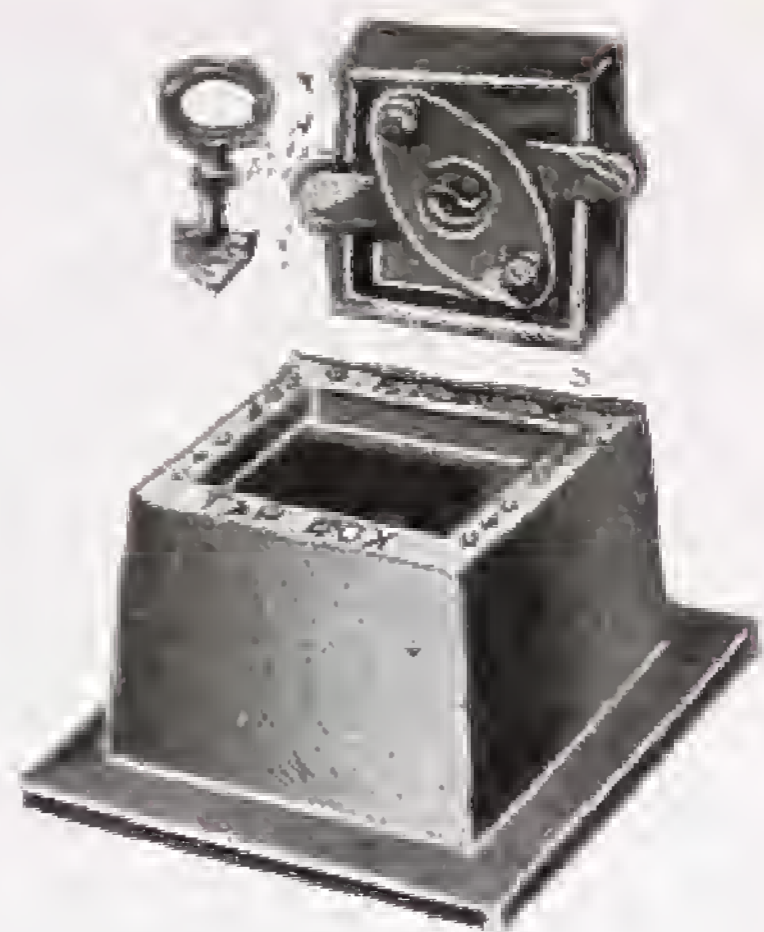

No. L 399
WIGAN
6 × 5½ × 4½ in. deep.



No. L 395
ST. HELENS
Hinged.
5½ × 5½ × 5 in. deep.



No. L 380
5 × 5 × 2½ in. deep.



No. L 397
GLOUCESTER
Hinged.
8 × 6½ × 3½ in. deep.

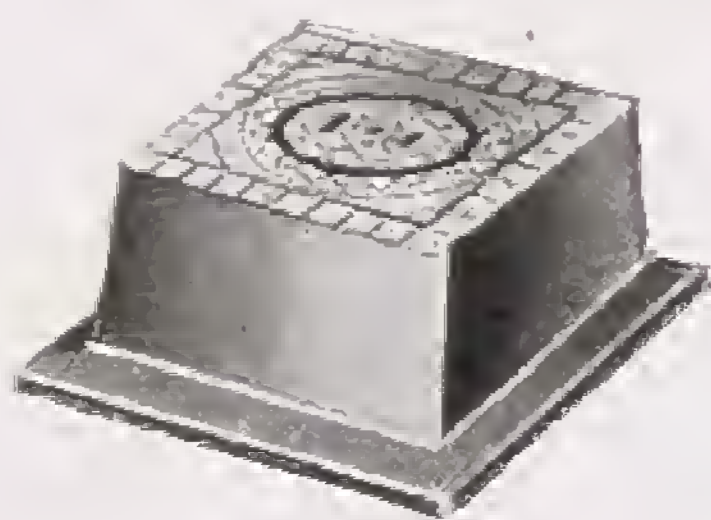

No. L 398
LINCOLN
Self-Locking.
5½ × 5½ × 3 in. deep.

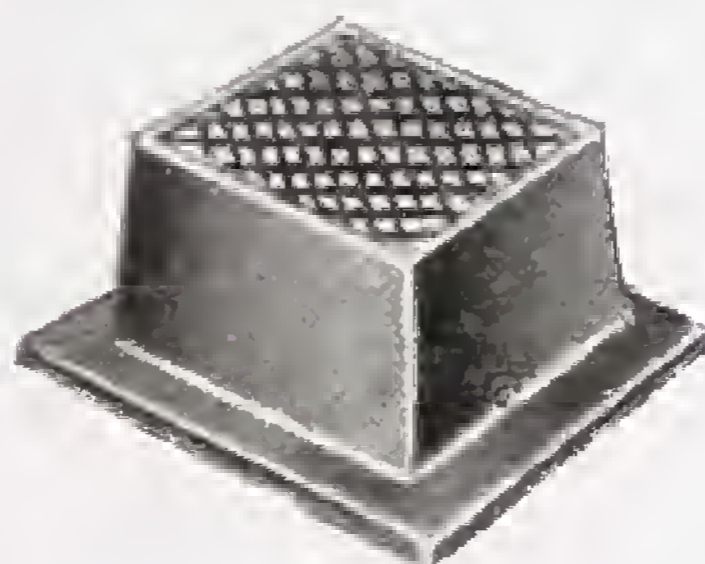

No. L 383
5 × 5 × 4 in. hinged.

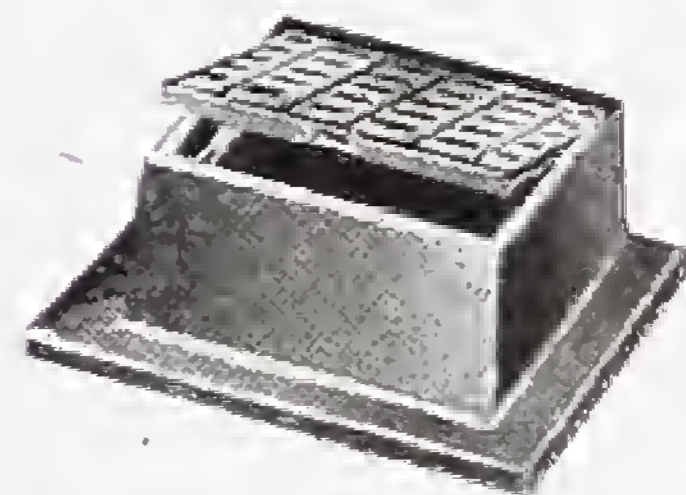

No. L 387
4½ × 4½ × 2½ in. deep
4½ × 4 × 3 "
6 × 6 × 3 "

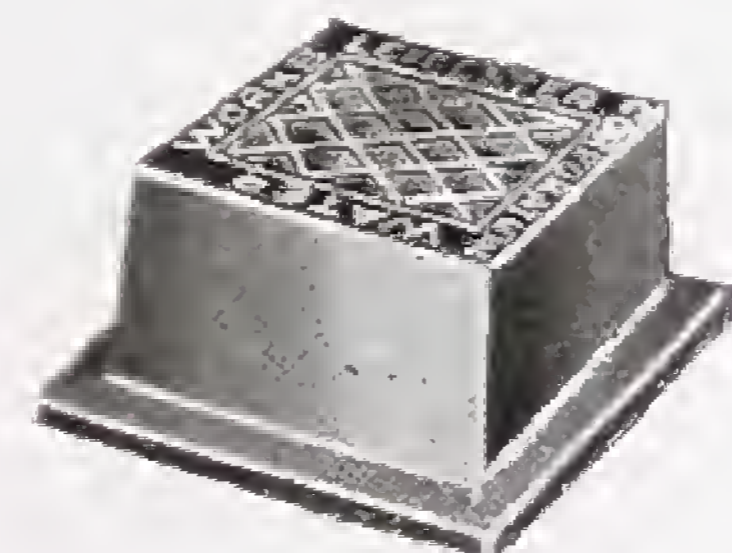

No. L 396
LEICESTER
5½ × 5½ × 3½ in. deep.



No. L 392. Heavy
6½ × 6½ × 6 in. deep
7½ × 7½ × 4 "
8½ × 6 × 5½ "
9½ × 7½ × 4 "
9½ × 7½ × 6½ "
10 × 10 × 6 "
12 × 8 × 6 "
13½ × 10½ × 3½ "

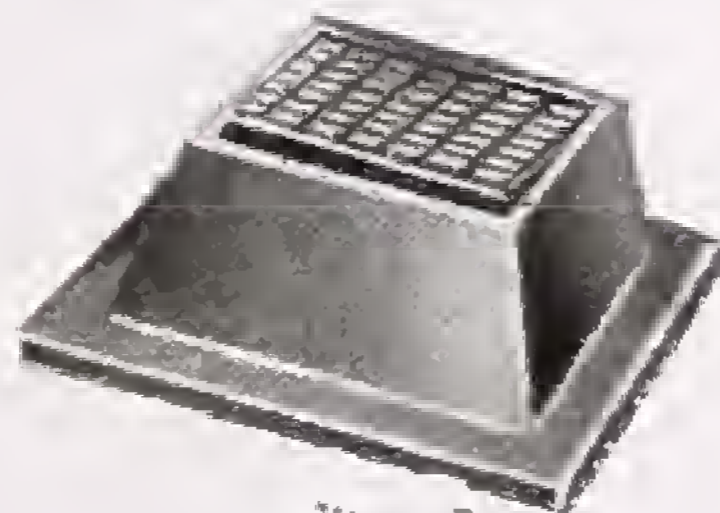

No. L 389
COVENTRY
6½ × 6½ × 4½ in. deep.

No. L 384
5½ × 5½ × 4 in. deep
6 × 5 × 3 "
6 × 5 × 4 "
6½ × 4½ × 3½ "
6 × 6 × 5 "
6 × 6 × 3 " Strong
5½ × 5½ × 5 " Heavy
5½ × 5½ × 4 "
1 in. Flange

For Orders of 3 dozen and upwards, Name and Address cast on free.

HYGIENIC ANTI-SPLASH WASTE PIPE TERMINAL

Made in cast-iron and coated with Black Petrifying Solution.

Any force of waste water instantly controlled. It stops splashing. It obviates waste matter being indiscriminately scattered about.



Section showing terminal with tail extended to build in cavity wall with waste pipe fitted.

General View showing length and with the Hole to receive Waste Pipe.

Note Adequate Caulking Provision.

Terminal shown when tightly sealed with caulking material.

No. B 925 TYPE 'A'

No. B 925. Short pattern which will take the place of the outside Brick.

No. B 926. Long pattern to go through a 9-in. cavity wall.

The Inner End "X" can be supplied extended as required to be built to the full thickness of any wall, at extra cost.

The unsatisfactory conditions created by the Lead Waste Terminus are entirely obviated.

Thousands already fixed by Councils and others.

Price on application stating quantity required.



No. B 926

Section showing Terminal built in with Lead Waste Pipe fitted.

BAXENDALE & CO. LTD.

No. H 1150

PAVEMENT LIGHTS

4-in. X 3-in. Lenses

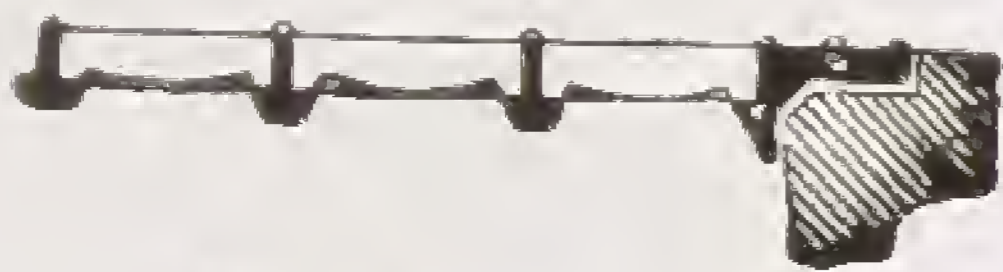
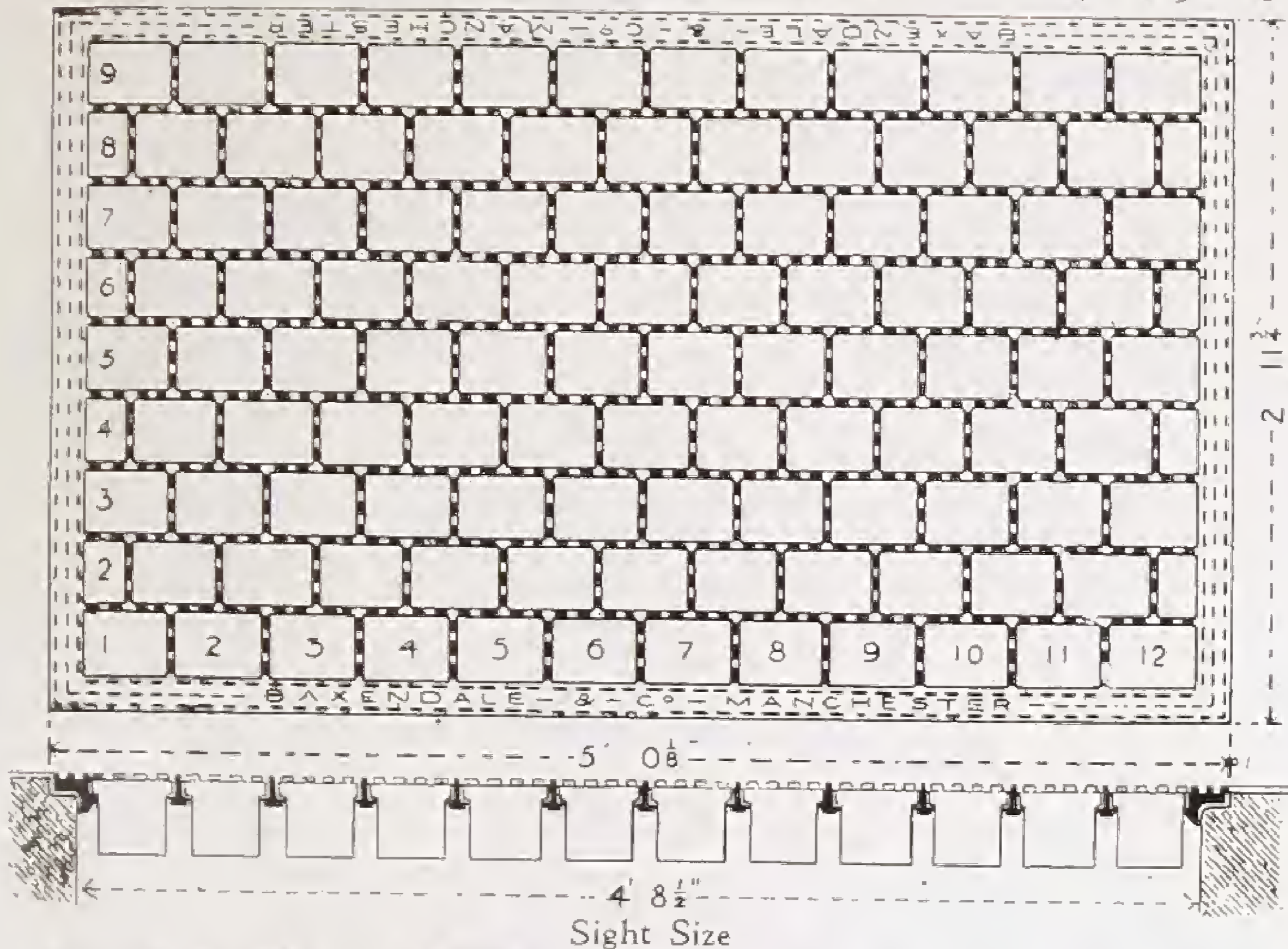

C Convex Lens

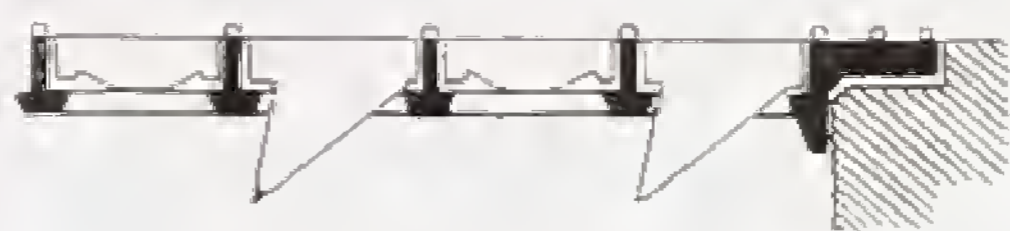

B Semi-Prism

Non-Slip Carbrum Lights, Stallboard Lights. Safety Cellar Flaps.
Prices on application giving full details of requirements.

STOCK PATTERN SIZES—No. H 1150 Pattern
Overall Dimensions, including 1 1/4-in. Flange all round.

Lenses in front	Depth 3 Lenses		Super		Depth 4 Lenses		Super		Depth 5 Lenses		Super		Depth 6 Lenses		Super	
	L'ngth	ft. in.	ft. in.	ft. in.	ft. in.	ft. in.	ft. in.	ft. in.	ft. in.	ft. in.	ft. in.	ft. in.	ft. in.	ft. in.	ft. in.	ft. in.
6	2 8 3/16	2 3/4	3	6	2 8 3/16	1 6 1/4	4	0	2 8 3/16	1 9 3/4	5	0	2 8 3/16	2 1 1/4	5	7
7	3 0 7/8	1 2 3/4	3	10	3 0 7/8	1 6 1/4	4	8	3 0 7/8	1 9 3/4	5	8	3 0 7/8	2 1 1/4	6	6
8	3 5 1/2	1 2 3/4	4	5	3 5 1/2	1 6 1/4	5	3	3 5 1/2	1 9 3/4	6	5	3 5 1/2	2 1 1/4	7	4
9	3 10 1/8	1 2 3/4	4	10	3 10 1/8	1 6 1/4	5	9	3 10 1/8	1 9 3/4	7	0	3 10 1/8	2 1 1/4	8	0
10	4 2 13/16	1 2 3/4	5	4	4 2 13/16	1 6 1/4	6	5	4 2 13/16	1 9 3/4	7	10	4 2 13/16	2 1 1/4	8	11
11	4 7 1/2	1 2 3/4	5	10	4 7 1/2	1 6 1/4	7	0	4 7 1/2	1 9 3/4	8	7	4 7 1/2	2 1 1/4	9	9
12	5 0 1/8	1 2 3/4	6	3	5 0 1/8	1 6 1/4	7	6	5 0 1/8	1 9 3/4	9	2	5 0 1/8	2 1 1/4	10	5

Lenses in front	Depth 7 Lenses		Super		Depth 8 Lenses		Super		Depth 9 Lenses		Super			
	Length	ft. in.	ft. in.	ft. in.	Length	ft. in.	ft. in.	ft. in.	Length	ft. in.	ft. in.	ft. in.		
6	2 8 3/16	2	4	6	2 8 3/16	2	8 1/4	7	2					
7	3 0 7/8	2	4	7	3 0 7/8	2	8 1/4	8	3	3 0 7/8	2	11 3/4	9	3
8	3 5 1/2	2	4	8	3 5 1/2	2	8 1/4	9	4	3 5 1/2	2	11 3/4	10	6
9	3 10 1/8	2	4	9	3 10 1/8	2	8 1/4	10	3	3 10 1/8	2	11 3/4	11	5
10	4 2 13/16	2	4	10	4 2 13/16	2	8 1/4	11	4	4 2 13/16	2	11 3/4	12	9
11	4 7 1/2	2	4	11	4 7 1/2	2	8 1/4	12	6	4 7 1/2	2	11 3/4	14	0
12	5 0 1/8	2	4	12	5 0 1/8	2	8 1/4	13	4	5 0 1/8	2	11 3/4	19	0

LANCASTER · LEEDS · BLACKPOOL

BAXENDALE & CO. LTD.

**PARAMOUNT
IMPROVED RAINWATER AND SOIL PIPES**



THE PARAMOUNT NEW (Regd.) EARS
Projecting and Flat

Undoubtedly the best Ears made.

They are unique, so specify Paramount for your next job.

THE PROJECTING EAR

**ALLOWS FROM $1\frac{1}{4}$ in. TO $1\frac{1}{2}$ in. CLEARANCE
FROM THE WALL**

**CAN READILY BE PAINTED
ALL ROUND.**

“PARAMOUNT” is our Registered Trade Mark.

MILLER STREET · MANCHESTER

**PARAMOUNT
IMPROVED RAINWATER AND SOIL PIPES**

with New (Regd.) ears—projecting and flat.

Six Vital Points not possessed by any other ears.

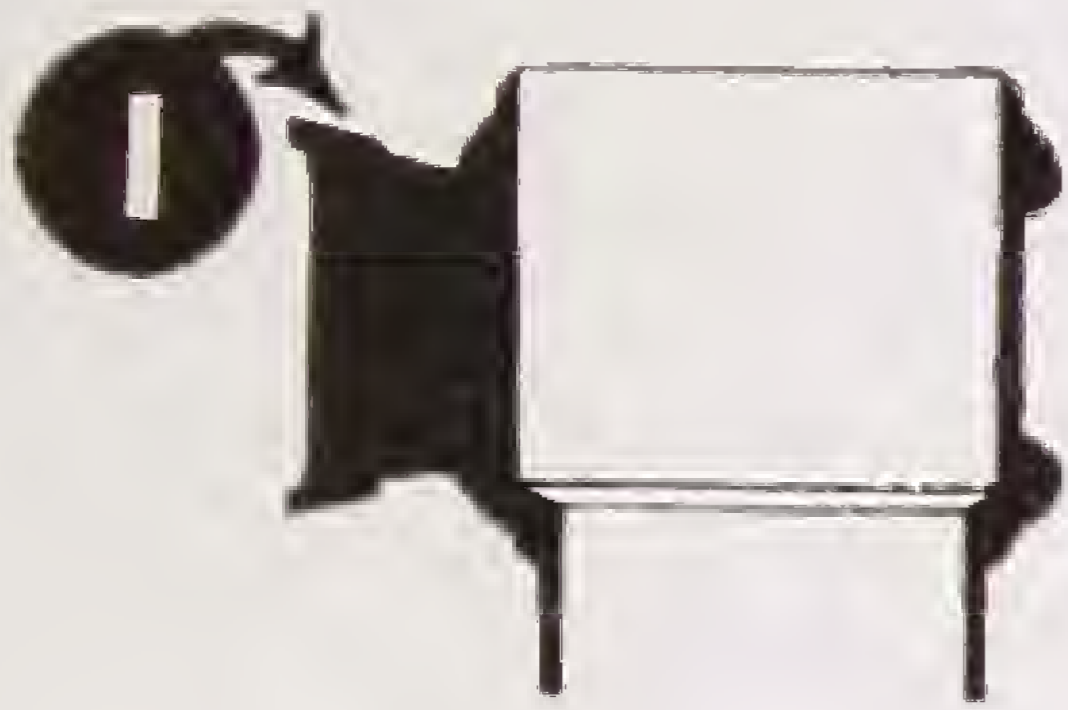

300% STRONGER
THE STRONGEST TYPE MADE

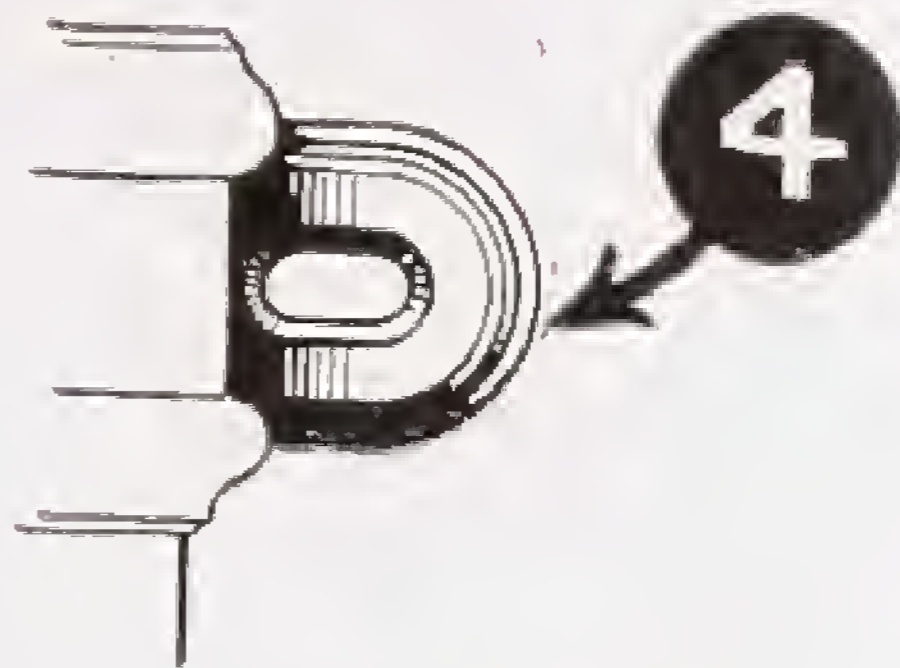

OVAL NAIL HOLES—THEREFORE—
NO MORE SLANTING NAILS
NO MORE BROKEN LUGS

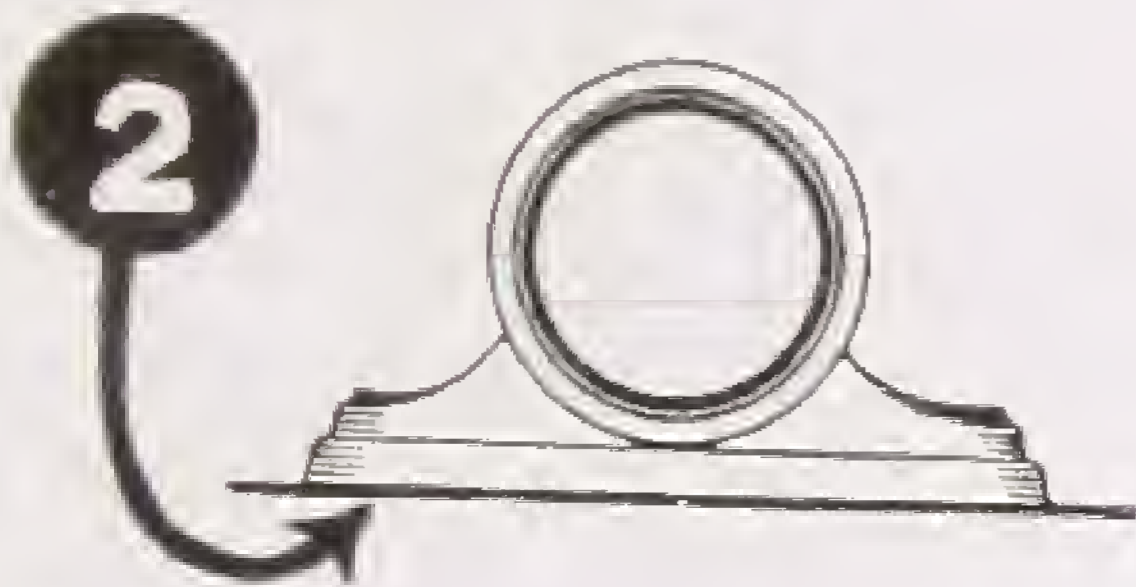

CAST IRON EXTENDS FULL LENGTH
ENSURING
MAXIMUM OF RIGIDITY

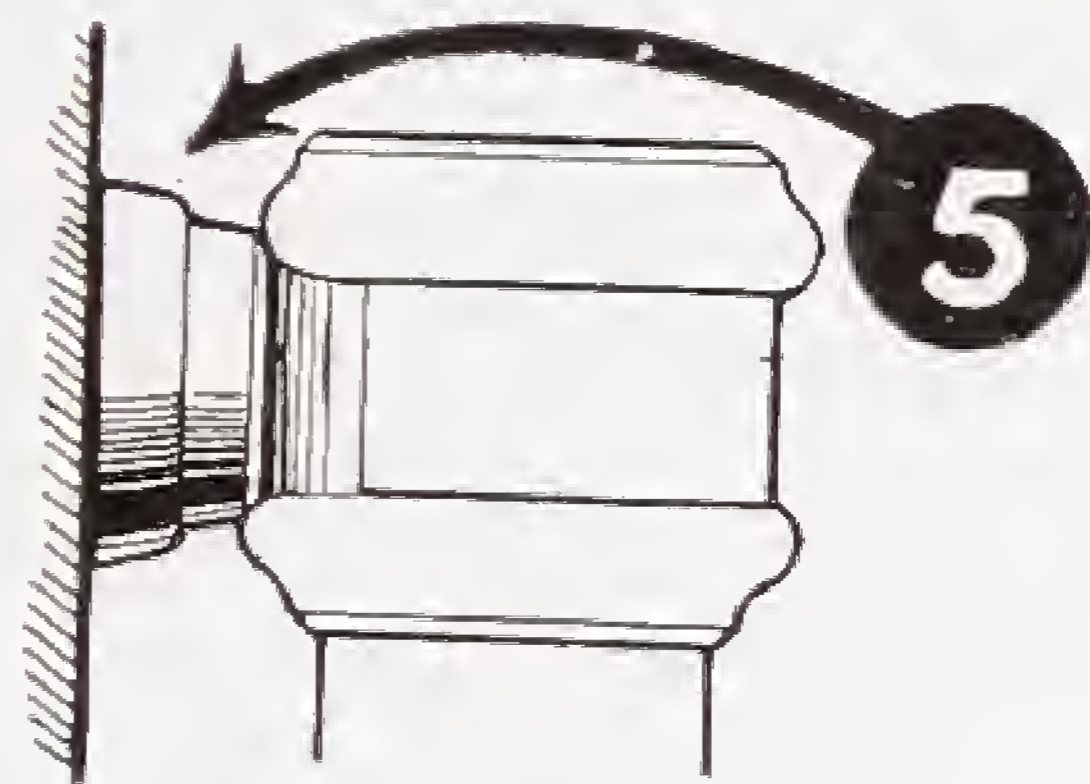

SLOPES FROM THE WALL
THEREFORE LITTLE RISK OF
CORROSION AT BACK OF EARS

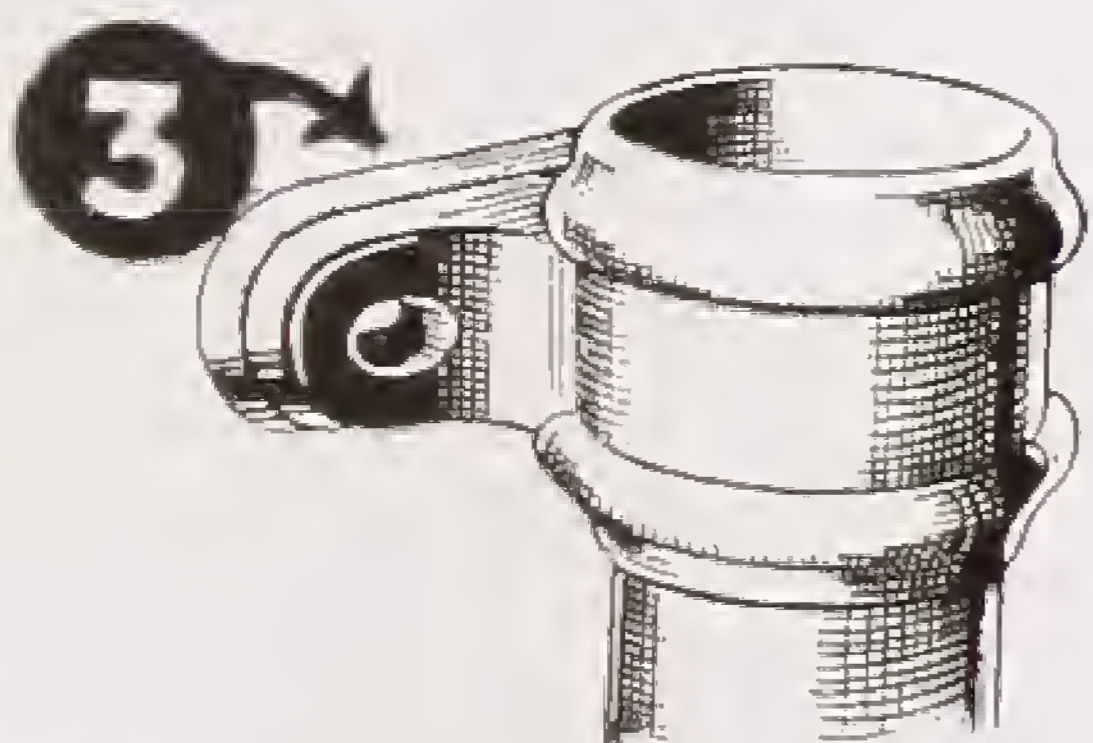

THE EAR HAS BEEN SO DESIGNED
THAT THE GRACEFUL MOULDING
OF THE SOCKET BEADS IS RETAINED
CAST IRON THROUGHOUT

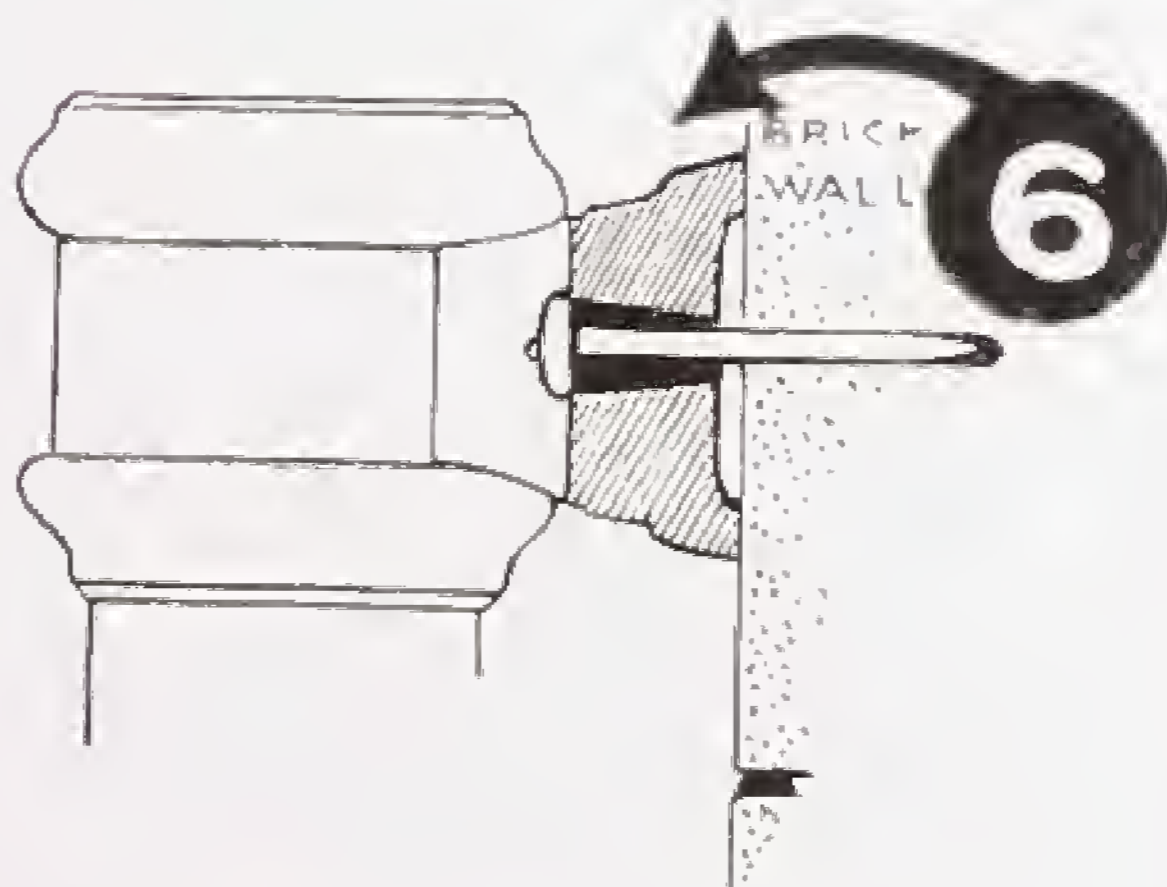

BOBBINS NOT REQUIRED
ORDINARY LENGTH PIPE NAILS
CAN BE USED

Points 2, 4 and 6 definitely establish Paramount
the cheapest eared pipe to fix. No extra price.

BAXENDALE & CO. LTD.

Paramount round Rain-Water and Stove Pipes and Connections



MILLER STREET - MANCHESTER

**PARAMOUNT
ROUND RAIN-WATER AND STOVE PIPES
AND CONNECTIONS**

R 83 ROUND PIPES, 6-ft. lengths. Short lengths as available at time of delivery.
 Sizes 2 2½ 3 3½ 4 4½ 5 6 in.

STANDARD LIST OF CONNECTIONS.

R 84	Shoes, Common	R 110	Swan Necks, 3-in. offset
R 85	„ Anti-splash	„	„ 4½ and 6-in. offset
R 86	Boots, 12 in. long overall	„	„ 9-in. offset
„	„ 15 „ „	„	„ 12 „
„	„ 18 & 20 in. long overall	„	„ 15 „
„	„ 24 in. long overall	„	„ 18 „
R 87	Boots, Double	„	„ 21 „
R 88	Straight Breeches Piece	„	„ 24 „
„	„	„	„ 27 „
„	„	„	„ 30 „
R 89	Bends, Square	R 112	Plinth Bends, 3-in. proj.
R 90	„ with Soot Door	„	„ 4½ „ 6 „
R 91	„ Obtuse	R 113	Side Ears
R 92	„ „ with Soot Door	R 114	Ordinary Ears on Bends, Swan-necks, and Branches
R 93	„ with 12-in. Tails	R 115	Small Plain Square Ears, Cast on
R 94	T-pieces	R 116	Small Ornamental Ears, Cast on
R 95	Y-pieces	R 117	Small Plain Proj. Ears, Cast on 1½ to 2-in. proj. to body
R 96	Branch Pieces, single	R 118	Small Ornamental Proj. Ears, Cast on 1½ to 2-in. proj. to body
R 97	„ „ double	R 119	Angle Ears, Cast on
R 98	„ „ cast on pipes (spigot)	R 120	Large Square Proj. Ears, Cast on. 1½ to 2-in. proj. to body
R 99	„ „ „ (faucet)	R 121	Flat Ears, Cast on, full depth of Socket either Plain or Beaded
R 100	„ „ Parallel (not ex- ceeding 6-in. centres)	R 122	Single Spigot Branch, Cast on pipe
R 101	Branches, curved arm, 4-in. 6 9 12 15 16 18-in. proj.	R 123	Single Socket Branch, Cast on pipe
R 102	Union Sockets		
R 104	Bonnet Tops with socket		
R 105	„ „ without socket		
R 106	Siphon Traps		
R 107	„ „ with door		
R 108	„ „ „ screwed plug		
R 109	Diminishing Pieces (large end)		

Stove Pipes are supplied without Ears unless otherwise ordered.

**PARAMOUNT SQUARE OR RECTANGULAR
RAIN-WATER PIPES AND CONNECTIONS**

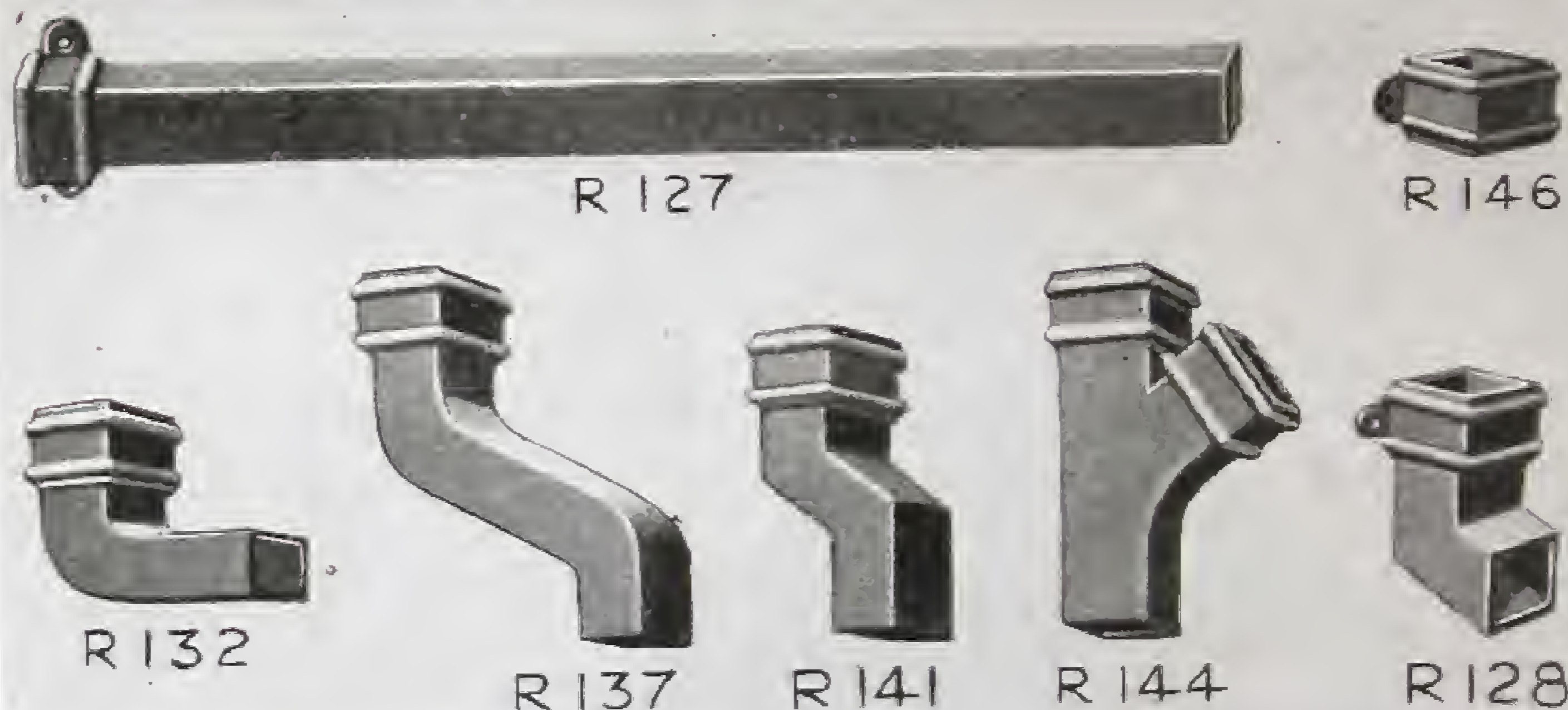

R 127 SQUARE OR RECTANGULAR PIPES in 6 ft. lengths. Short lengths as available at time of delivery.

Sizes : $2\frac{1}{2} \times 2$ 3×2 $3 \times 2\frac{1}{2}$ 3×3 $3\frac{1}{2} \times 2\frac{1}{2}$ $3\frac{1}{2} \times 3$ $3\frac{1}{2} \times 3\frac{1}{2}$ 4×2 in.
 $4 \times 2\frac{1}{2}$ 4×3 $4 \times 3\frac{1}{2}$ 4×4 $4\frac{1}{2} \times 3$ $4\frac{1}{2} \times 3\frac{1}{2}$ 5×3 $5 \times 3\frac{1}{2}$ in.

STANDARD LIST OF CONNECTIONS

R 128	Shoes	R 141	Plinth Offsets, proj.
R 129	„ Side	„	3
R 130	„ Corner	„	4 $\frac{1}{2}$	„	...
R 132	Elbows, Front, Square	„	6	„	...
R 133	„ „ Obtuse	R 142	Corner Plinths
R 134	„ Side, Square	R 143	Side „
R 135	„ „ Obtuse	R 144	Branch Pieces, single
					R 145	„ „ double
R 136	Corner Bends	R 146	Union Sockets
R 137	Front Offsets	...	3-in. proj.	...	R 148	Small Plain Projecting Ears cast on 1 $\frac{1}{2}$ to 2-in. proj. to body
„	„	...	4 $\frac{1}{2}$ & 6-in. proj.	...	R 149	Small Orna. Projecting Ears cast on 1 $\frac{1}{2}$ to 2-in. proj. to body
„	„	...	9-in. proj.	...	R 149a	Large Square Projecting Ears, cast on 1 $\frac{1}{2}$ to 2-in. proj. to body
„	„	12	„	...	R 149b	Flat Ears, cast on full depth of Socket either Plain or Beaded
„	„	15	„	...	R 147	Angle Ears, cast on
„	„	18	„	...				
„	„	21	„	...				
„	„	24	„	...				

PARAMOUNT

H.R. GUTTERS AND CONNECTIONS



R 170

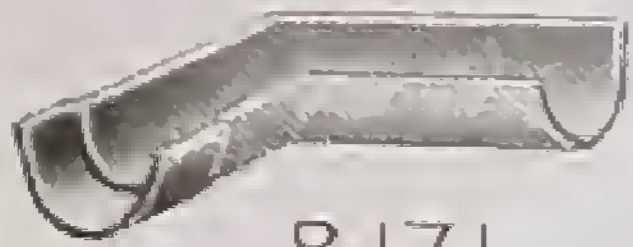

R 171

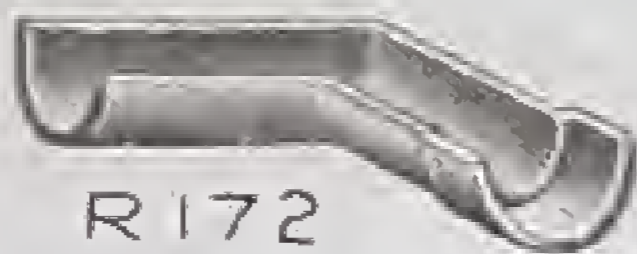

R 172



R 173

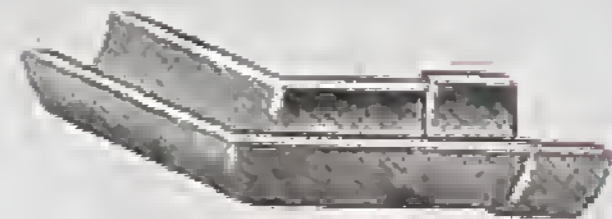

R 174



R 175

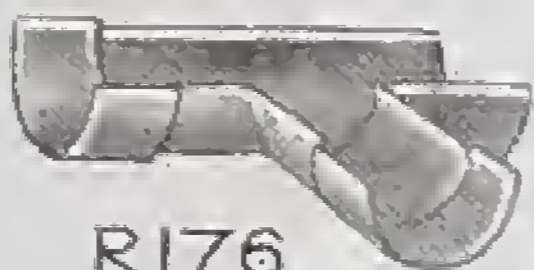

R 176



R 177



R 178



R 179



R 180



R 181



R 182



R 184



R 185



R 186

R 170 H.R. GUTTER, in 6 ft. lengths. Short lengths as available at time of delivery.
 Sizes 3 3½ 4 4½ 5 6 in.

STANDARD LIST OF CONNECTIONS

R 171	Angles, Square, Right-hand ...	R 180/1	Stop Ends ...
R 172	" " Left-hand ...		Drops, loose or cast on... ..
R 173	" Obtuse 135° Left-hand ...	R 182	Facia Brackets, cast Light ...
R 174	" " Right-hand ...	R 184	Wrought-Iron Gutter Brackets, to drive ...
R 175	Nozzle Pieces ...	R 185	Wrought-iron Gutter Brackets, to screw ...
R 176	Tee Pieces ...	R 186	Gutter Bolts and Nuts ...
R 177	End Pieces with Drop Spigot end ...	R 187	Drop Gratings, cast ...
R 178	" " " Faucet end ...		
R 179	Union Clips ...		

R 190 BEADED H.R. GUTTER, in 2, 3, 4 and 6-ft. lengths.
 Sizes 3 3½ 4 4½ 5 6 in.

STANDARD LIST OF CONNECTIONS

R 191	Angles, Ordinary Pattern	R 195	Angles, D.B.M.S. Pattern ...
R 192	Nozzles, Ordinary Pattern ...	R 196	Nozzles, D.B.M.S. Pattern ...
R 193	Tee Pieces, Ordinary Pattern...	R 197	Tee Pieces, D.B.M.S. Pattern

**PARAMOUNT
O.G. GUTTERS AND CONNECTIONS**

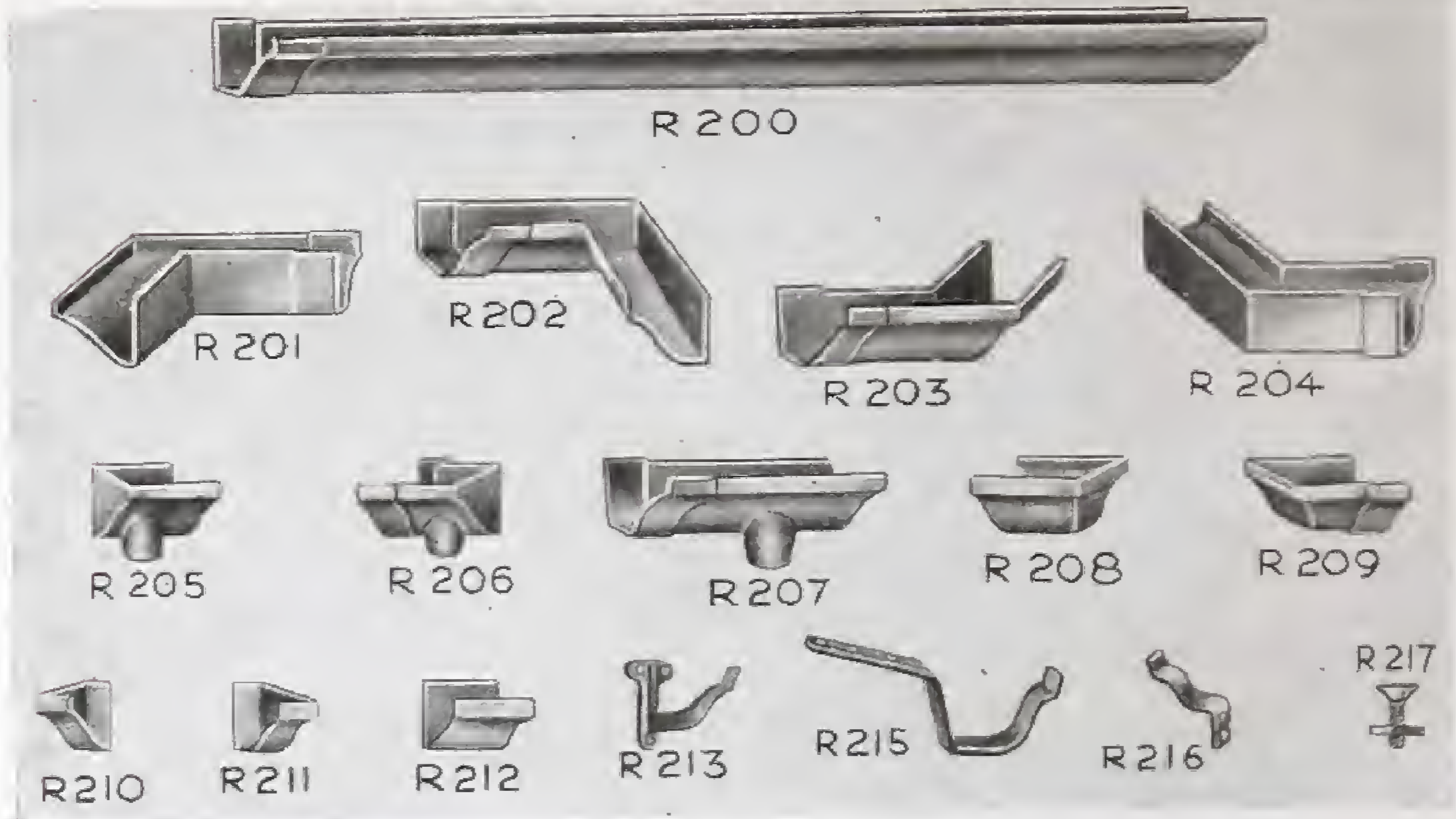

R 200 O.G. GUTTER, in 6-ft. lengths. Short lengths as available at time of delivery.

Sizes 3 3½ 4 4½ 5 6 in.

STANDARD LIST OF CONNECTIONS.

R 201	Angle Square, External	...	R208/9	Return Stop Ends	...
R 202	Angle Square, Internal	...	R210/1	Stop Ends	...
R 203	Angle Obtuse 135° External	...		Drops, loose or cast on	...
R 204	Angle Obtuse 135° Internal	...	R 212	Union Clips	...
R 205	Stop Ends, with Drop Spigot end	...	R 213	Fascia Brackets, cast Light	...
R 206	Stop Ends, with Drop Faucet end	...		Weight per dozen not exceeding (lbs.)	...
R 207	Nozzle Pieces	...	R 215	Gutter Brackets, to screw (W.I.)	...
			R 216	Fascia Brackets	...
			R 217	Gutter Bolts and Nuts	...

R 218 LOOSE DROPS TO SCREW ON FLAT-BOTTOMED GUTTERS

Sizes 2 2½ 3 3½ 4 4½ 5 6 in. dia.

“PARAMOUNT” is our Registered Trade Mark.

**PARAMOUNT
PLAIN AND ORNAMENTAL GUTTERS**

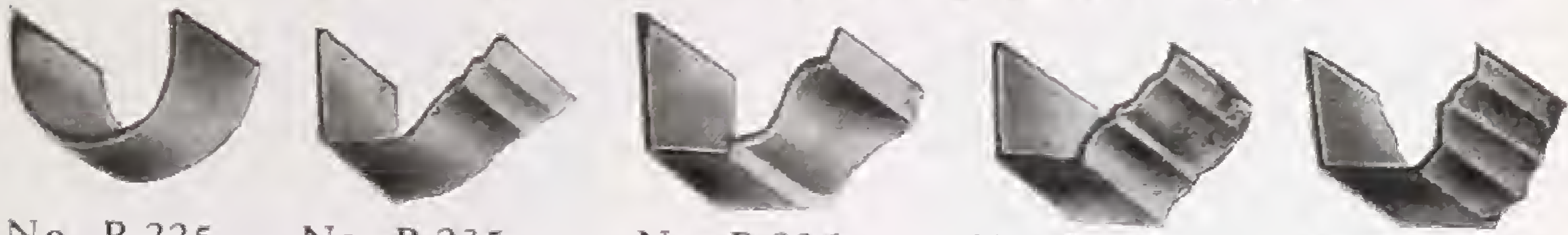

No. R 225 No. R 235 (Old No. 13) No. R 236 (Old No. 14) No. R 237 (Old No. 15) No. R 238 (Old No. 16)

No. R 225 Deep H.R. Gutters, painted. Sizes : 4 x 3 4 1/2 x 3 4 1/2 x 3 1/2 5 x 4 in.

No. R 235 Notts. O.G. Gutter, painted. Sizes : 4, 4 1/2, 5, 6 in.

No. R 236 }
No. R 237 } Sizes : 3 1/2 x 2 4 x 3 4 1/2 x 3 1/2 5 x 4 6 x 4 6 x 4 1/2 7 x 4 in.
No. R 238 }

Shorts up to 2 ft. as 1 yard. Over 2 ft. to 4 ft. as 1 1/2 yards.
Over 4 ft. as 2 yards.

**ORNAMENTAL GUTTER CONNECTIONS
THESE CAN BE SUPPLIED TO SUIT ANY GUTTER
SHOWN IN CATALOGUE**



No. R 250
External Angle

No. R 260
Union Clip

No. R 251
Internal Angle



No. R 256
Return
Stop End.

No. R 258
Flat
Stop End

No. R 252
Projecting
Nozzle Piece

No. R 257
Return
Stop End

No. R 259
Flat
Stop End



No. R 254
Drop Cast
on Corner

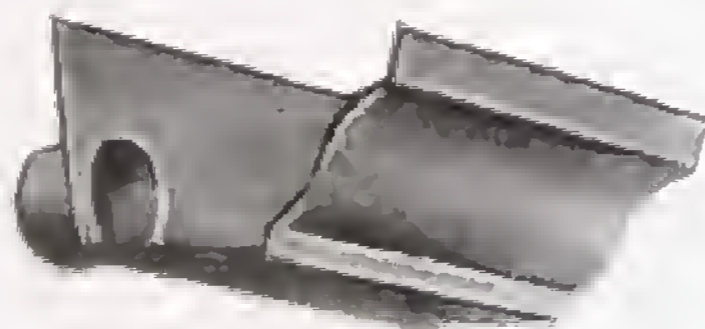

No. R 255
Drop Cast
on Back

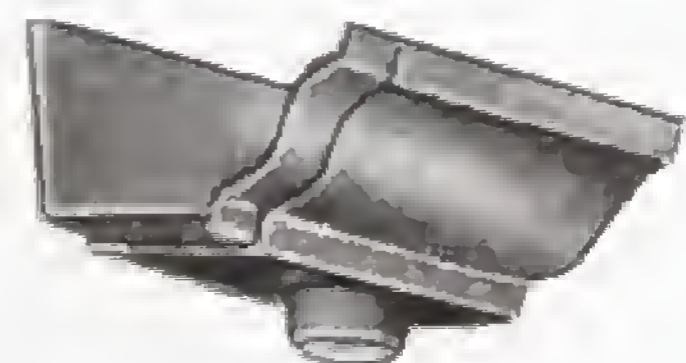

No. R 253
Nozzle Piece

Nozzles and Angles, Square and Obtuse, 135°, charged as 1 yard of Gutter.
Stop Ends, charged as one-third yard each.
Ornamental Stop Ends charged as half-yard each.



No. R 243

No. R 244

No. R 245

Sizes : 5 x 4 6 x 4 7 x 4 8 x 5 in.

No. R 243 Box Gutters, painted. Sizes 4 x 3 extra.

No. R 244 Valley Gutters, painted

No. R 245 Boundary Wall Gutters

Quotations against Specifications

PARAMOUNT RAIN WATER HEADS



No. R 834



No. R 835



No. R 830



No. R 652



No. R 615



No. R 832



No. R 810



No. R 833



No. R 656



No. R 813



No. R 837

PARAMOUNT RAIN WATER HEADS

No.	Wide In.	Proj. In.	High In.	Out- let In.	No.	Wide In.	Proj. In.	High In.	Out- let In.
R 834	14	7 $\frac{3}{4}$	7	up to 6	R 385	18	7 $\frac{1}{4}$	6 $\frac{1}{4}$	up to 4
	14 $\frac{1}{2}$	7	6 $\frac{1}{4}$	5					
	16	6	6	4					
	18	6	6	4	R 615	9 $\frac{3}{8}$	6 $\frac{1}{8}$	7 $\frac{1}{2}$	1 $\frac{1}{2}$
	18	12	8	6		9 $\frac{3}{8}$	6 $\frac{1}{8}$	7 $\frac{1}{2}$	2
	20	7	7	5		10 $\frac{1}{4}$	7 $\frac{1}{4}$	8	2 $\frac{1}{2}$
	22	8	8	6		10 $\frac{1}{2}$	7 $\frac{1}{2}$	8	3
	25 $\frac{1}{2}$	13 $\frac{1}{2}$	12	6		12	8 $\frac{3}{8}$	9 $\frac{1}{4}$	3 $\frac{1}{2}$
	35	13 $\frac{1}{2}$	12	6		12	8 $\frac{3}{4}$	9 $\frac{1}{4}$	4
						13	9 $\frac{3}{4}$	10	5
R 830	10	7 $\frac{1}{4}$	10	up to 4		15	10 $\frac{3}{4}$	11	6
	10 $\frac{1}{4}$	7 $\frac{1}{4}$	9 $\frac{3}{4}$	3 × 3					
	12 $\frac{1}{2}$	7 $\frac{3}{4}$	12	4 × 3	R 810	13 $\frac{1}{2}$	8 $\frac{3}{4}$	12	5 × 4
Angle	7 $\frac{1}{4}$	10 $\frac{1}{4}$	10	4	Angle	9 $\frac{3}{4}$ sq.	13 $\frac{3}{4}$	12	4 × 4
R 832	8 $\frac{1}{2}$	6	14 $\frac{1}{2}$	3 $\frac{1}{2}$					
R 833	12	6 $\frac{3}{4}$	6	up to 4	R 656	13	7	7 $\frac{3}{4}$	Up to 6
	13 $\frac{1}{2}$	9	10	6					
	14 $\frac{1}{2}$	7	6 $\frac{1}{2}$	5					
	17 $\frac{1}{2}$	9 $\frac{1}{2}$	10	6					
	20 $\frac{1}{4}$	9 $\frac{1}{4}$	10	6	R 652	10	7 $\frac{3}{4}$	10	up to 4
	24	9	10	6					
	31 $\frac{3}{4}$	9	10	6					
R 813	12	6 $\frac{3}{4}$	6	up to 6	R 837	12	5 $\frac{1}{4}$	5	Up to 3
	16 $\frac{1}{4}$	9	6	6					

Outlet:—Round, all sizes up to and including 4 in. Square or Rectangular, all sizes up to and including 4 × 4 in.

● The heights given are exclusive of drop, and widths exclusive of ears. Square or rectangular drops can be cast on rectangular heads to suit requirements.

**PARAMOUNT
WROUGHT-IRON GUTTER BRACKETS**



No. R 676
To screw
1 in. to 5 in.
Black or
Galvd.



No. R 769
To screw to fascia
1 in. to 5 in.
Black or Galvd.



No. R 770
To drive.

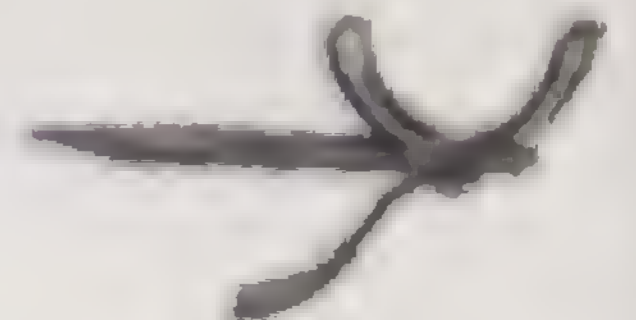

No. R 771
Spat,
with stay, to drive



No. R 775
Adjustable
To Drive.



No. R 778
For side fixing.
To screw to spat.



No. R 774
To screw to
spat.



No. R 779
For side fixing.
To screw to spat.



No. R 780



No. R 781



No. R 782



No. R 783

Made to suit all sizes and shapes of Gutters.



No. R 758
Steel
Pipe
Nails
1/2 to 6 in.



No. R 761
Gutter
Screws
Galvanized.
1/2, 1 1/2 in.



No. R 762
Gutter
Bolts
and Nuts
1/2, 1 1/2, 1 3/4 in.



No. R 760
Wrought
Iron Pipe
Hooks
1 to 6 in.



No. R 764
Iron
Projecting
Bobbin
1, 1 1/2, 2, 3 in.



No. R 765
Wood
Projecting
Bobbin
1, 1 1/2, 2, 3 in.

**PARAMOUNT
CAST-IRON SANITARY CONNECTIONS**

For 3½ and 4 in. Soil Pipes, L.C.C. and 3⅞ in. to take Earthenware Pipe.

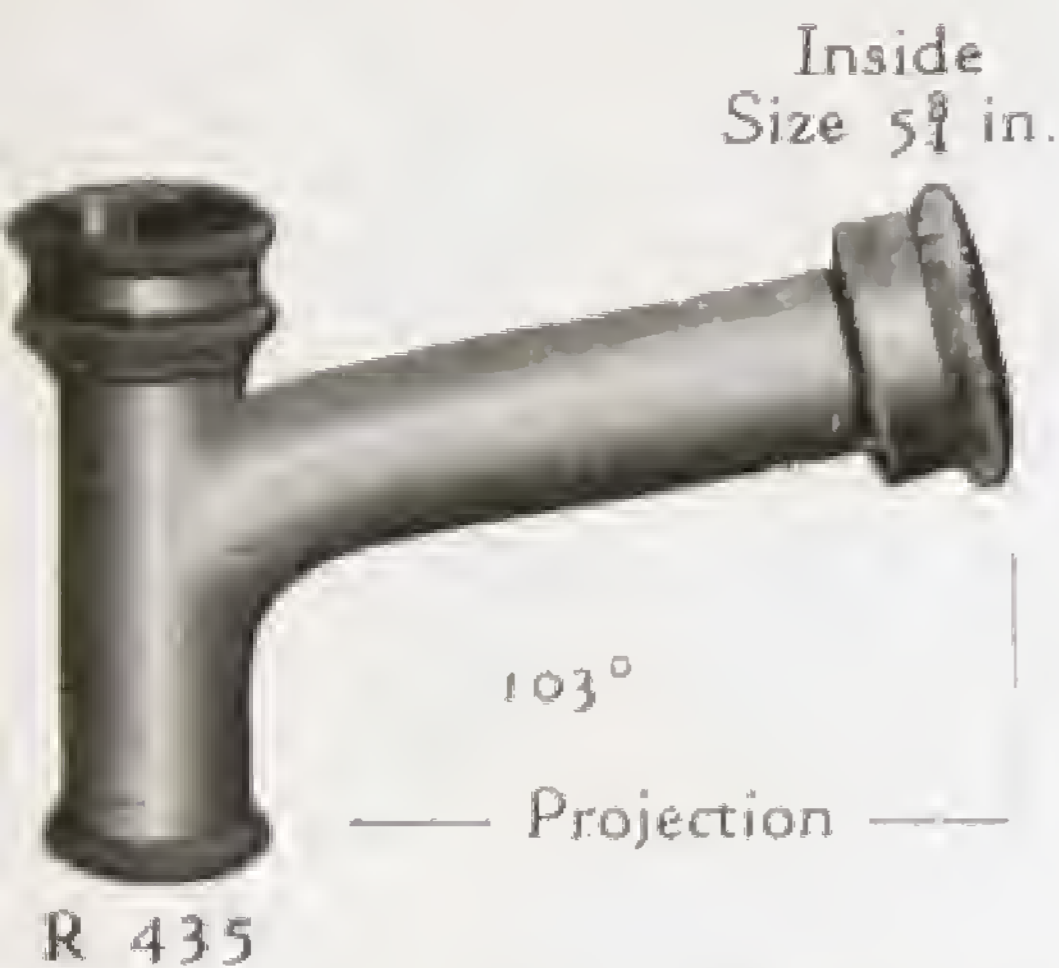

“P” TRAP BRANCH PIECE

Inside Size 5⅞ in.



CONNECTING PIPE



“S” TRAP BRANCH PIECE

Inside Size 5⅞ in.



LONG BEND

STANDARD SIZES

R 435	P Branch	}	6, 9, 12, 15, 17, 18, 21, 24 in. proj.
R 436	S Branch		
R 437	Connecting Pipe		

Extra for Anti-Siphon Branch, Cast on

R 439 Long Bends (inside sizes) :—

0 × 10 12 × 12 14 × 14 15 × 15 16 × 16 16 × 14 17 × 17 20 × 20 22 × 22 in.

Stocked COATED, GALVANIZED, or GLASS-ENAMELLED to Order.

BAXENDALE & CO. LTD.

PARAMOUNT SOIL PIPES AND CONNECTIONS
L.C.C. $\frac{1}{2}$ and $\frac{3}{4}$ -in. Metal



DRICES and APPLICATION for CAST IRON UNDERGROUND DRAIN PIPES

MILLER STREET · MANCHESTER

HAIR FELT SHEETS AND DAMP COURSE
CANVASBACKED HAIR FELT



No. L 454

For Flat and Gull Waist Pipes, Cylinders, Boilers, etc.
 Supplied ready for use, has a strip of Canvas on one side, which laps over the edge of the preceding roll, thus making a complete joint of very good appearance.

In Rolls 24 ft long x 4 ft. or 5 ft. wide.

Made in Stockrooms commencing at No. 1 to No. 10.

No. L 454 - 1/2 IN. HAIR FELT

In long lengths. In Rolls 24 ft long by 4 ft and 5 ft wide.

Made in Stockrooms commencing at No. 1 to No. 10.

No. L 457 - 1/4 IN. HAIR FELT

In Rolls 24 ft x 4 ft.

For covering Boilers, Cylinders, Steam Pipes, etc.

1/4
 1/2
 3/4
 1
 1 1/4
 1 1/2
 1 3/4
 2
 2 1/4
 2 1/2
 2 3/4
 3
 3 1/4
 3 1/2
 3 3/4
 4
 4 1/4
 4 1/2
 4 3/4
 5
 5 1/4
 5 1/2
 5 3/4
 6
 6 1/4
 6 1/2
 6 3/4
 7
 7 1/4
 7 1/2
 7 3/4
 8
 8 1/4
 8 1/2
 8 3/4
 9
 9 1/4
 9 1/2
 9 3/4
 10

1/4	1/2	3/4	1	1 1/4	1 1/2	1 3/4	2
1/4	1/2	3/4	1	1 1/4	1 1/2	1 3/4	2

Prices on application.
 Canvas joint on a Roll.

DAMP COURSE

BRANDED PURE BITUMEN DAMP COURSE for GRAVE

In rolls of 24 ft long.

24 x 12 1/2 14 18 24 inches wide.

BRANDED PURE BITUMEN DAMP COURSE

In rolls of 24 ft long.

24 x 12 1/2 14 18 24 inches wide.



The great remedy for Damp Walls is BUTEX, see page 147.

SEMI-ROTARY WING PUMPS

Maximum suction lift with a sound foot valve,
20 ft.

- B 2750—Double Acting, iron, brass fitted, steel spindle.
- B 2751—Double Acting, brass, steel spindle.
- B 2748—Double Acting, gun metal, steel spindle.
- B 2747—Double Acting, all iron, steel spindle. For destructive fluids.
- B 2752—Quadruple Acting, iron, brass fitted, steel spindle.
- B 2753—Quadruple Acting, brass, steel spindle.
- B 2749—Quadruple Acting, gun-metal, steel spindle.

Unless the Suction Pipe is fitted with a Foot Valve we cannot be responsible for the satisfactory working of Semi-Rotary Pumps.

Capacities per hour given are approximate only, and calculated with a 3 ft. Suction and Delivery.



Size No. ..	0	1	2	3	4	5	6	7	8	
Diam. of suction and delivery ..	$\frac{1}{2}$	$\frac{3}{4}$	1	1 $\frac{1}{4}$	1 $\frac{1}{2}$	1 $\frac{3}{4}$	2	2	2	in.
Cap. per hour, double acting	240	420	450	570	870	960	1,320	1,560	2,310	galls.
Cap. per hour, quadruple acting	—	495	615	930	1,200	1,440	1,860	2,100	2,760	„

No. B 2741



No. B 2742



HAND DIAPHRAGM PUMPS

- B 2741.—Cast-iron painted Diaphragm Lift Pump, with side inlet screwed for tube.
- B 2742.—Cast-iron painted Diaphragm Lift and Force Pump, with brass unions, one handle

Dia. of Suction Pipe or Hose for B 2741	2	2 $\frac{1}{2}$	3	4	in.
Dia. of Suction and Delivery Pipes or Hose for B 2742	2	2 $\frac{1}{2}$	3	—	„

Fittings for Above

- Brass half-hose unions for Fig. B 2741 and 2 $\frac{1}{2}$ in. and 3 in. size Fig. B 2742 Pumps.
- Brass iron to hose unions for 2 in. size Fig. B 2742 pumps.
- 3 or 4 ply internal spiral wired suction hose. 3 or 4 ply delivery hose.
- Wrought iron clips for securing hose to unions.
- Cast-iron footvalve and strainer with shank ribbed for hose.
- Cast-iron footvalve and strainer screwed for tube.



No. B 4600

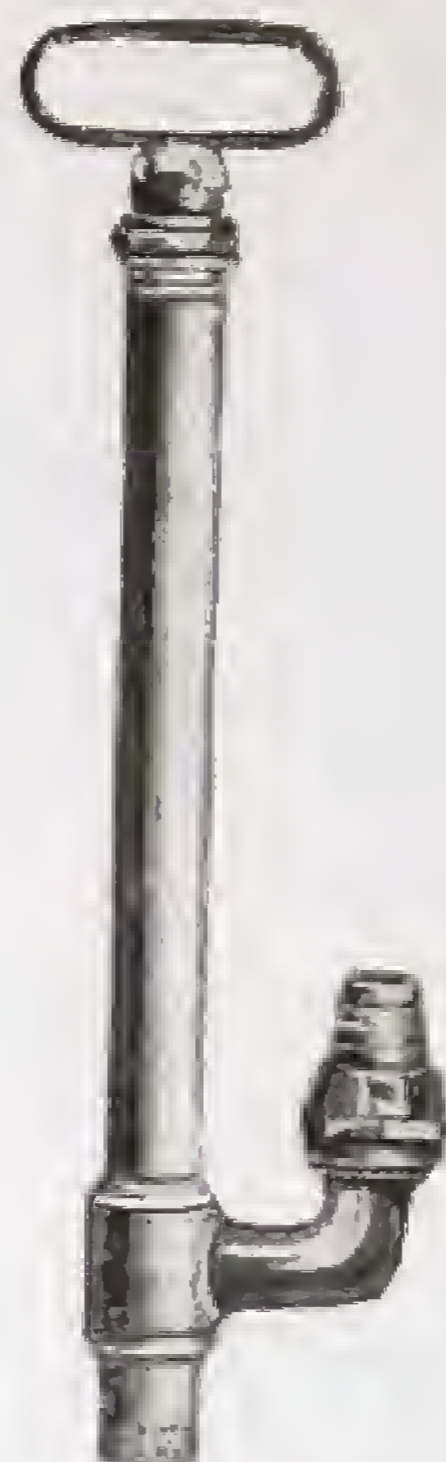

No. B 4602

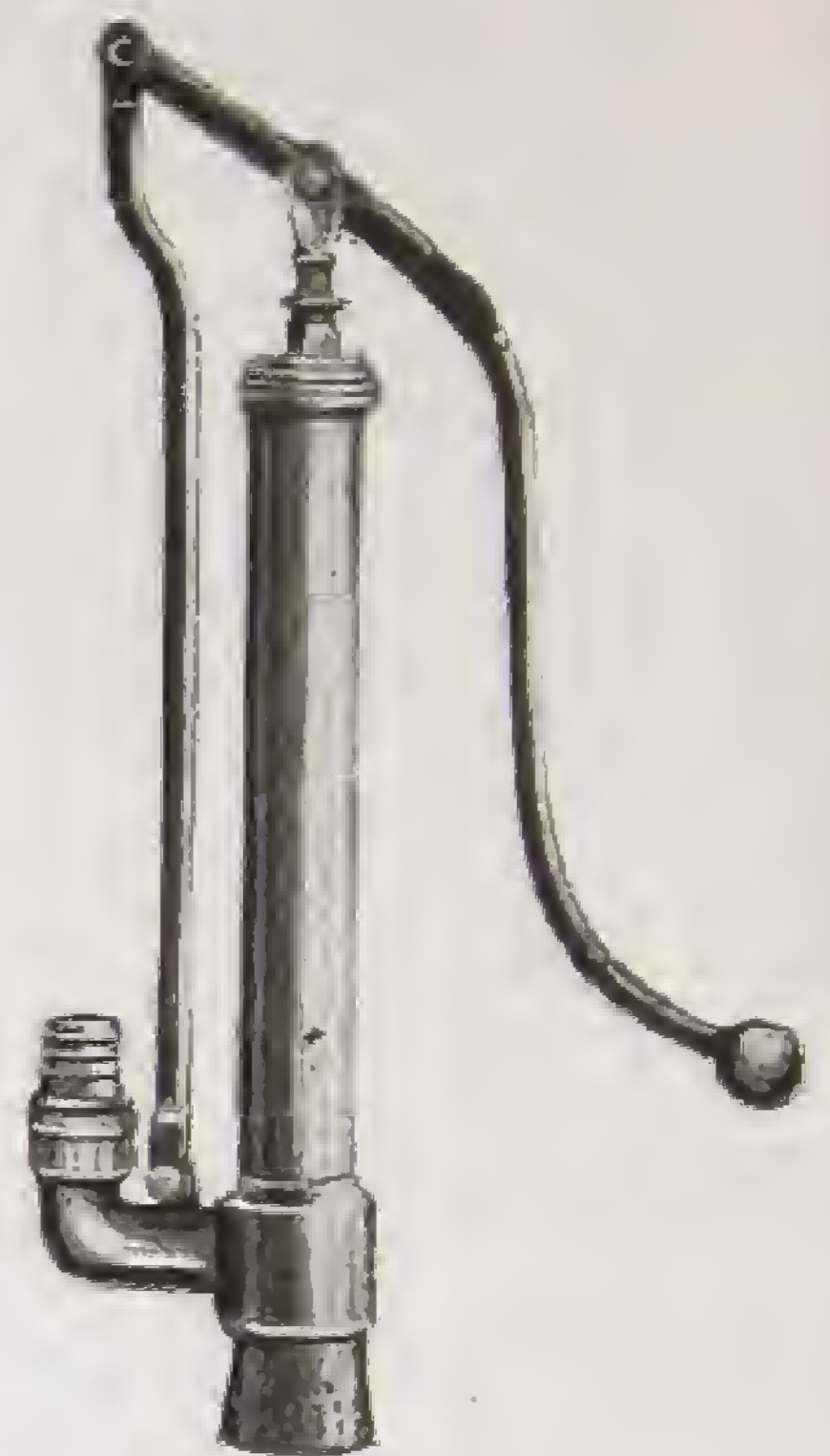

No. B 4601

PLUMBERS' BRASS FORCE PUMPS

No. B 4600. With Stuffing Box and Tail Pipe ; $1\frac{1}{4}$ in. hose connection.
Extra for leather hose, as illustrated.

No. B 4601. With Iron handle and $1\frac{1}{4}$ in. hose connection.

No. B 4602. With Brass Plunger.



No. B 2761

HYDRAULIC TEST PUMPS

For Pressures up to 1,050 lb. per sq. inch.

Suitable for Proving Boilers, Cisterns, Pipes,
Cocks, Castings, etc.

The pump is single acting and is mounted upon a wrought iron tank. It is fitted with pressure gauge and shut off and release valves, by means of which the apparatus being tested may be kept under pressure and the return flow of liquid to the tank may be controlled. The outlet of the pump is screwed 1 in. gas thread, and is fitted with a cap and liner to take $\frac{3}{4}$ in. hose, the hose being secured by Jubilee hose clips.

No. 1 Size. Is for pressures up to 750 lbs. per sq. in. with $1\frac{3}{16}$ in. dia. ram. The pump body is of special iron suitable for high pressures, the plunger is of bronze, the valves and seatings are of gunmetal, the handle is of wrought iron and a pressure gauge is supplied, also a short length of steel suction pipe.

No. 2 Size. Is for pressures up to 1,050 lbs. per sq. in. with 1 in. dia. ram and pump body of high pressure gunmetal.

A standard 6 ft. length of $\frac{3}{4}$ in. best rubber armoured delivery hose, with brass outlet connection screwed for $\frac{3}{4}$ in. gas, can be supplied at an extra price.

If required, a galvanized tank can be supplied instead of the wrought iron one included, at an extra cost.

STUART PISTON PUMP

No. B 2746

with $\frac{1}{2}$ h.p. A/C. motor, capacity 240 g.p.h. working at 70 ft. head.

SPECIFICATION

This pump is capable of delivering to a height of 175 feet including pipe friction and suction lift not exceeding 25 feet.

Bore and Stroke : $1\frac{1}{2}$ in. \times $1\frac{5}{8}$ in.

Speed : 240 r.p.m.

Pump Barrel cast-iron with renewable brass liner. Main Bearings of ball type well spaced and conservatively loaded.

Electric Motor runs at 1,425 r.p.m.

Suitable Footvalve and Strainer Extra.

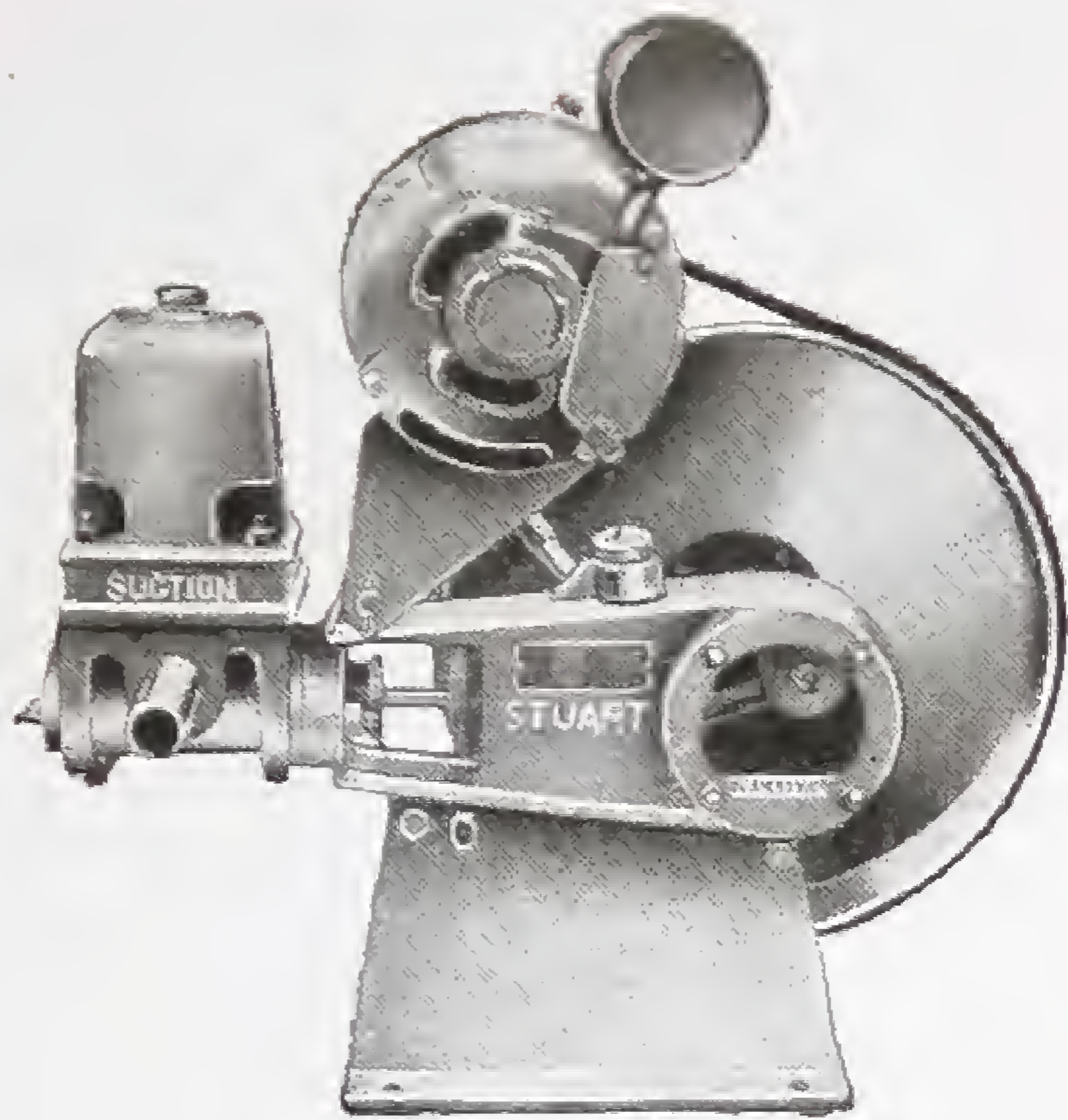

No. B 6290 ELECTRIC SUMP PUMP

With automatic float switch for cellar and bilge pumping.

SPECIFICATION

The pump is electrically-driven and runs on ball bearings; supplied for any standard A.C. single phase or D.C. voltage from 12 v. upwards. The pump is rigidly suspended from the motor by a brass tube which encases the spindle driving the rotor. The entrance of the spindle into the pump casing is sealed by a patent pump gland. Impeller and underwater parts are all made of non-rusting material. A cylindrical water strainer surrounds the orifice of the pump with delivery outlet for $\frac{3}{4}$ in. hose.

Delivery in g.p.h. when pumping to height of:

5 ft.	10 ft.	15 ft.	20 ft.
320	260	220	160 g.p.h.

Extras :

- Automatic Float Switch—
- Single or Double pole
- D.C. Float Switch.

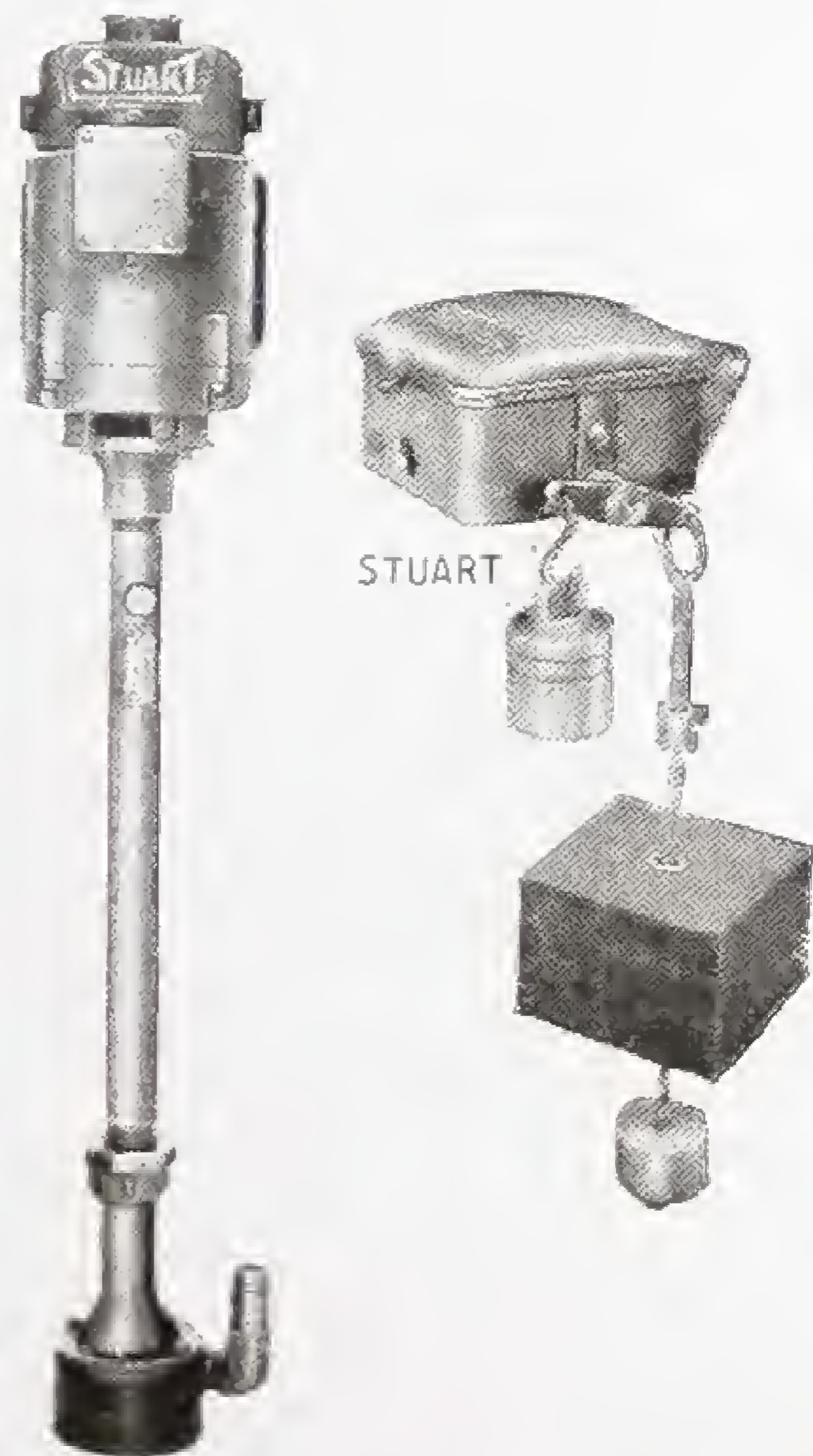



CENTRIFUGAL PUMP

No. B 2765

Suitable for Fountains, Science Laboratories, Advertising Displays, Water Supply on Yachts and all purposes where a constant flow of liquid at low cost is required.

SPECIFICATION

Ball-bearing series wound motor. The impeller on the extended motor spindle is the shrouded type, and there is no end thrust. Speed 4,000 r.p.m. Connections are for rubber hose — this provides easy means of connection — screwed connections would involve too great a strain on a small pump. Pump outlet may be vertical or horizontal. Water Seal : — The Stuart Pump Gland. Lubrication : — The ball-bearings of the motor are packed with grease.

Pattern No.	10	12
Size of Connections...	$\frac{1}{2}$	1 in.
Overall Length	8 $\frac{1}{2}$	10 $\frac{1}{2}$ in.
Width between bolt holes C to C	3	4 in.
Overall Height	5	5 $\frac{3}{4}$ in.

Footvalve and Strainer Extra.

Full Directions sent out with every pump.

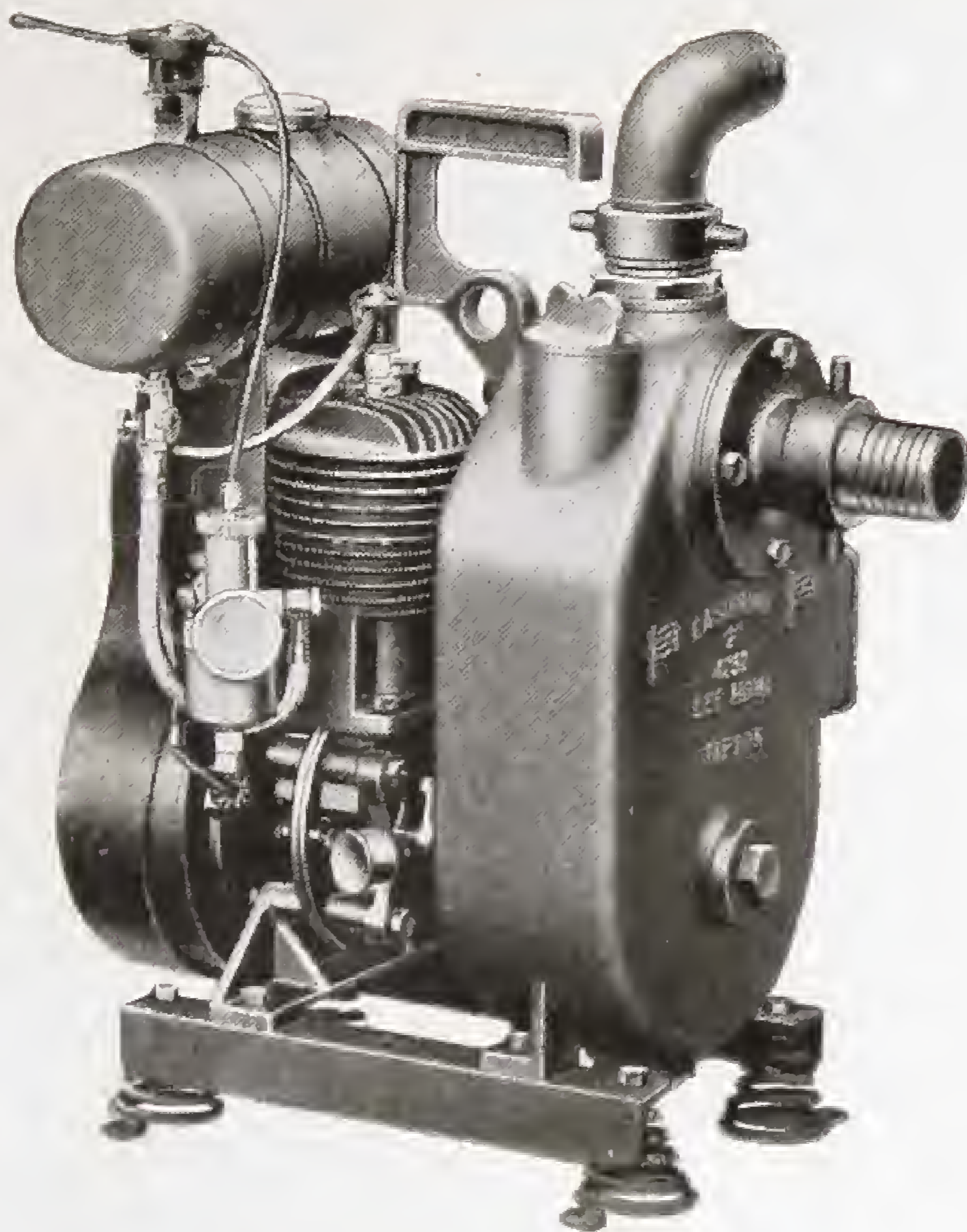

No. AG 4252E. 1½ in. Size.
With 80 c.c. J.A.P. Two-stroke Petrol Engine.

No. AG 4252E

'EASIPRIME' SELF-PRIMING PETROL DRIVEN CENTRIFUGAL PUMPS

These handy light-weight pumps have been specially designed for contractors' work where portability is essential. They can also be used extensively for agricultural purposes, including the pumping of liquid manure and will pass solids up to 3 in. in diameter.

The pump will readily self-prime from any lift up to 25-feet providing the casing is full of water when starting up.

A rubber flap valve prevents the water in the casing from siphoning down the suction hose. The pump casing is made of aluminium and is mounted on a corresponding spigot on the engine to ensure perfect alignment. The impeller is made of gunmetal and is of the single inlet, open vaned type suitable for dealing with dirty or silty water without undue wear.

No footvalve is necessary but a strainer is recommended and is included. The pump is mounted on four resilient springs, therefore making a strictly level foundation unnecessary.

Size and Description	Weight
1½ in. size with 80 c.c. J.A.P. Two-stroke Petrol Engine	63 lb.
1½ in. size with 98 c.c. J.A.P. Four-stroke Petrol or Paraffin Engine	72 lb.
2 in. size with 147 c.c. Villiers Two-stroke Petrol Engine	79 lb.
2 in. size with 208 c.c. Villiers Four-stroke Petrol or Paraffin Engine	107 lb.
3 in. size with 256 c.c. Villiers Four-stroke Petrol Engine	156 lb.
3 in. size with 256 c.c. Villiers Four-stroke Paraffin Engine	150 lb.

SIGMUND *Thermopak*

No. B 2767

THERMOPAK

1 in. to 4 in. branch diameter.

This central heating accelerator offers a new standard of efficiency and reliability. It is of precision construction, glandless, super-silent, and designed to fit inexpensively into a pipe layout.

Special features are Low Running Cost, Low Installation Cost, Low Resistance, Simple Mechanism. No Supports Required; Water Lubricated, Trouble-free Heat Distribution, Direct Mounting, and No Maintenance.

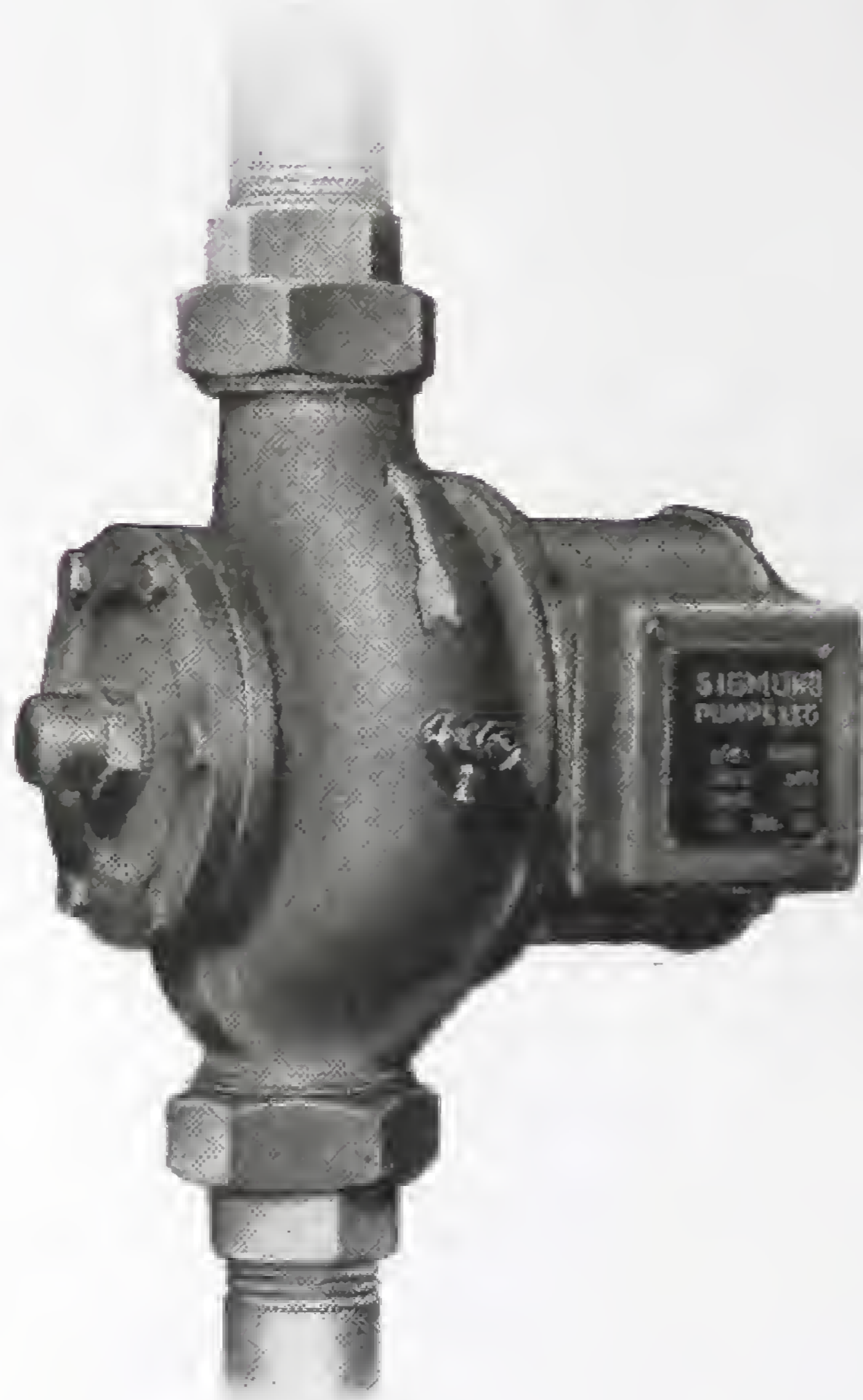

We can quote for Accelerators of any size and type against specifications. Descriptive Booklets sent on request.

Type	Pipe Connection	Branches	
		BSP	
		Inlet	Outlet
CR 1	Screwed	in. 1	in. 1
CR 2	Screwed	1 1/4	1 1/4
CR 3	Flanged	1 1/2	1 1/2
CR 4	Flanged	2	2
CA 1	Screwed	1 1/4	1 1/4
CA 2	Flanged	2	2
CA 3	Flanged	2 1/2	2 1/2
CA 4	Flanged	3	3

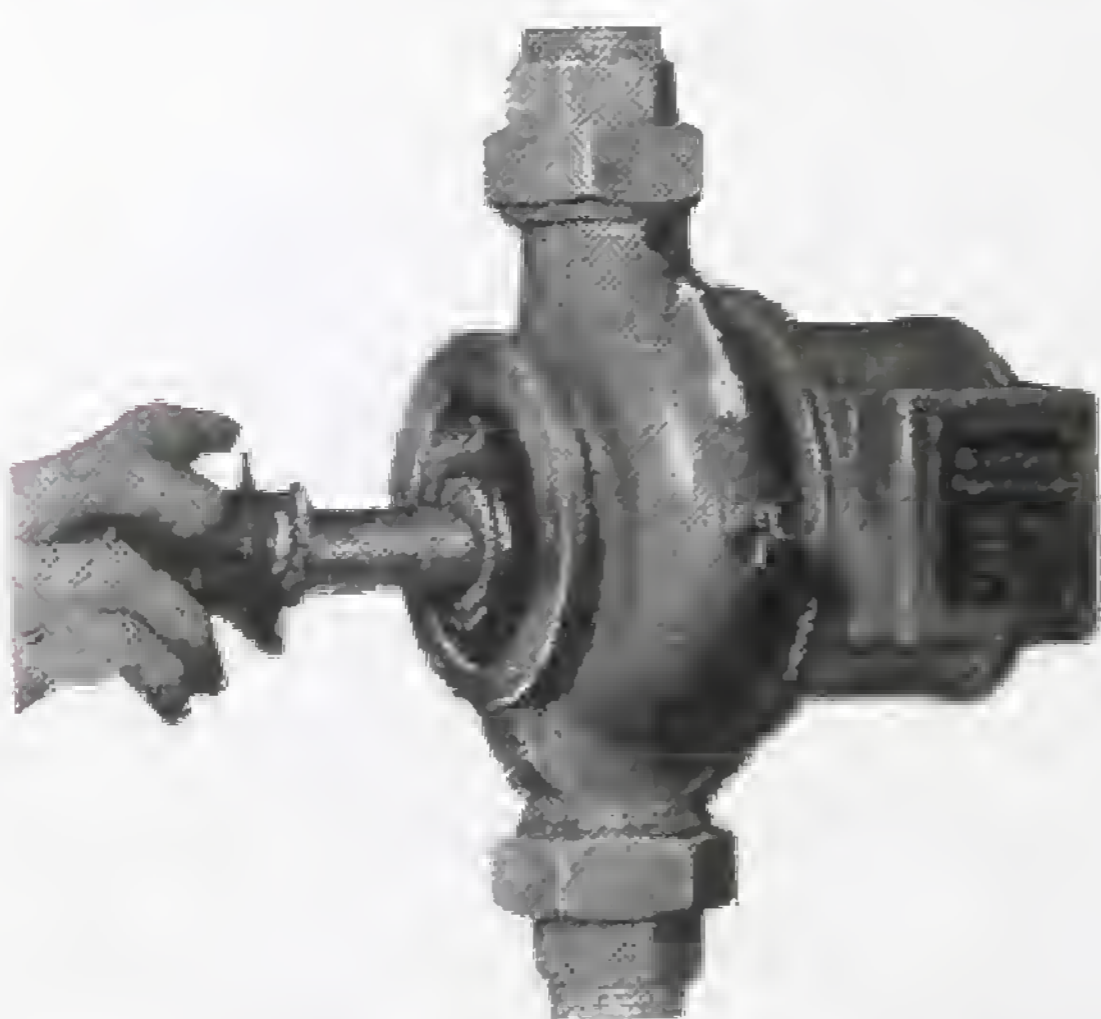

Complete rotating element can be quickly withdrawn.

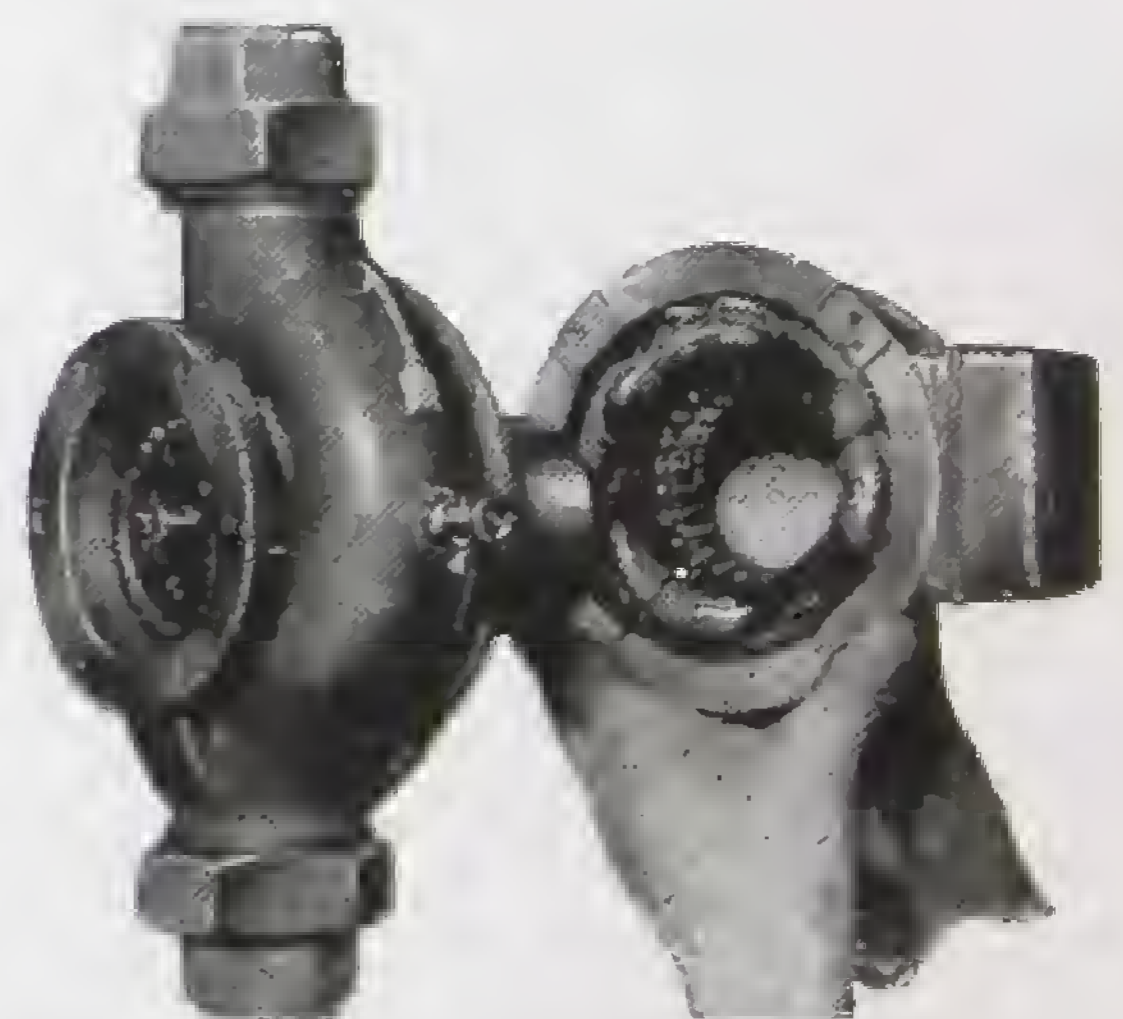

Electrical unit easily accessible.

LUCAS

OIL-O-MATIC

Low pressure burner

For Central Heating Boilers

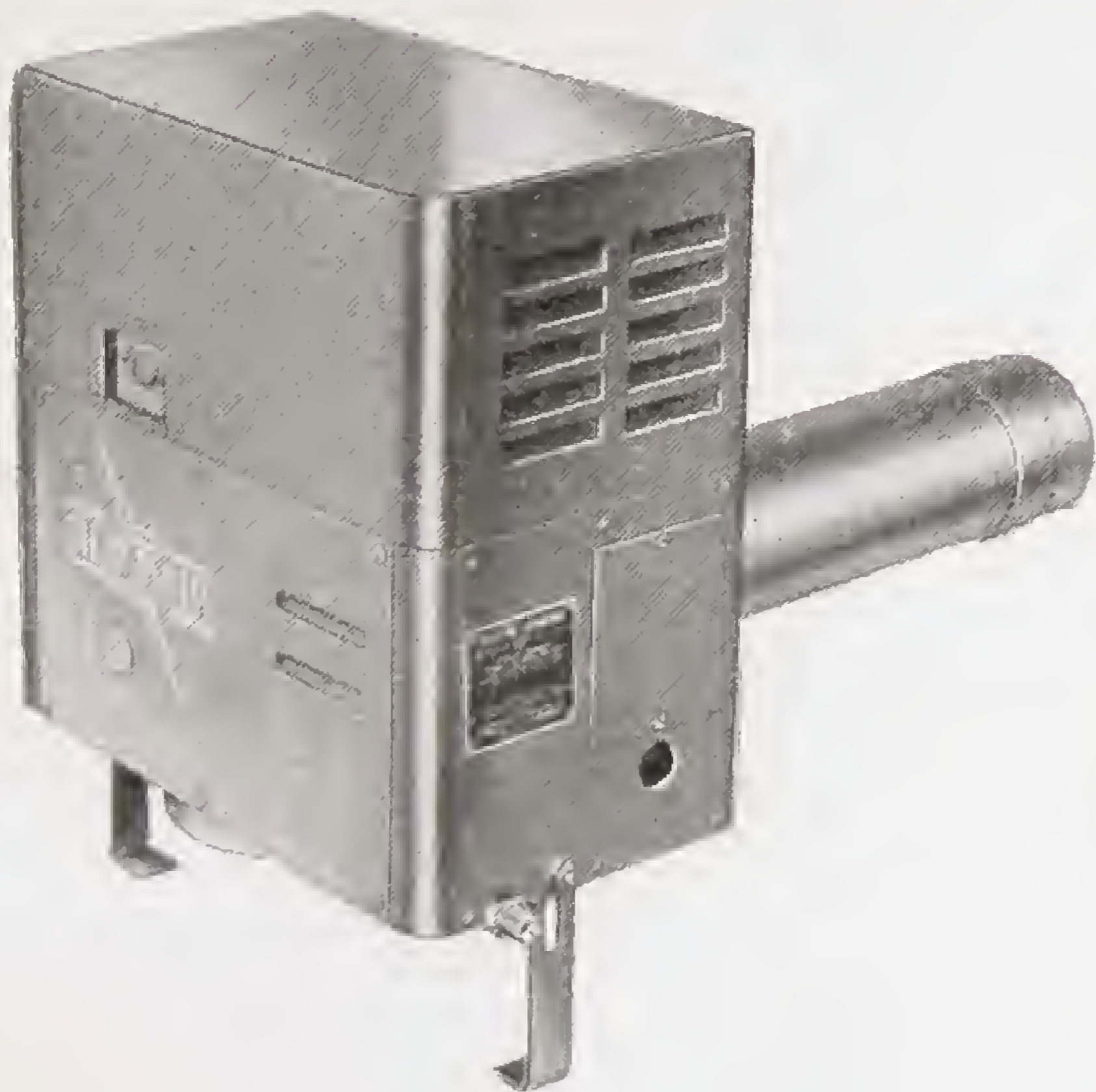

A compact low pressure unit using domestic fuel oil, designed for use with boilers requiring a burner with a maximum heat output up to 205,700 B.T.U. per hour.

It is simple, quiet, and automatic in operation: designed to eliminate service and maintenance work because the unit is automatically lubricated and employs a burner of the self-cleaning type.

This unit comprises essentially an air pump and

fan driven by an electric motor, oil-container, oil supply valve, oil-burner nozzle, and automatic auxiliary and air controls.

When the unit is switched off, air pressure in the container is dissipated through the pressure regulator, air pump, and air line to the nozzle to provide a clean shut-off, any oil in the nozzle or airline on shut-down being siphoned back to the container: this eliminates oil carbonization in the nozzle by reflected heat from the combustion chamber after shut-down.

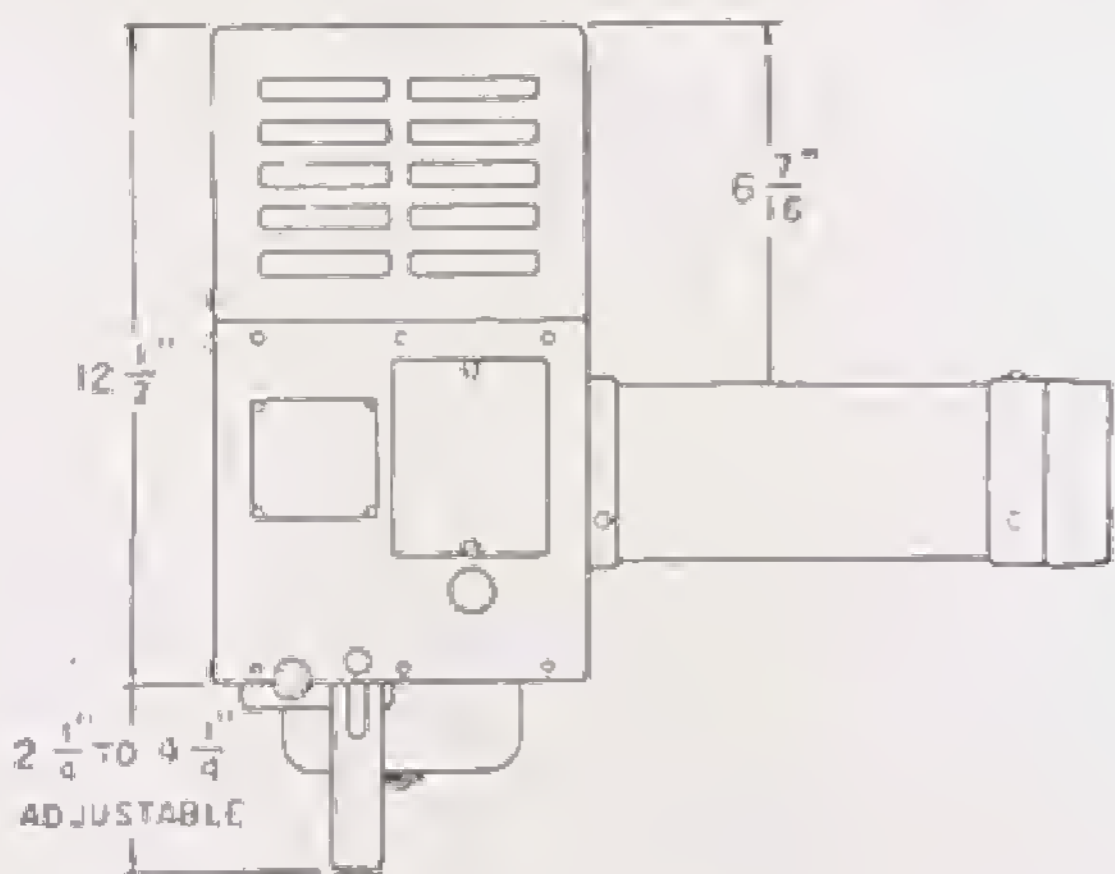

SIDE VIEW

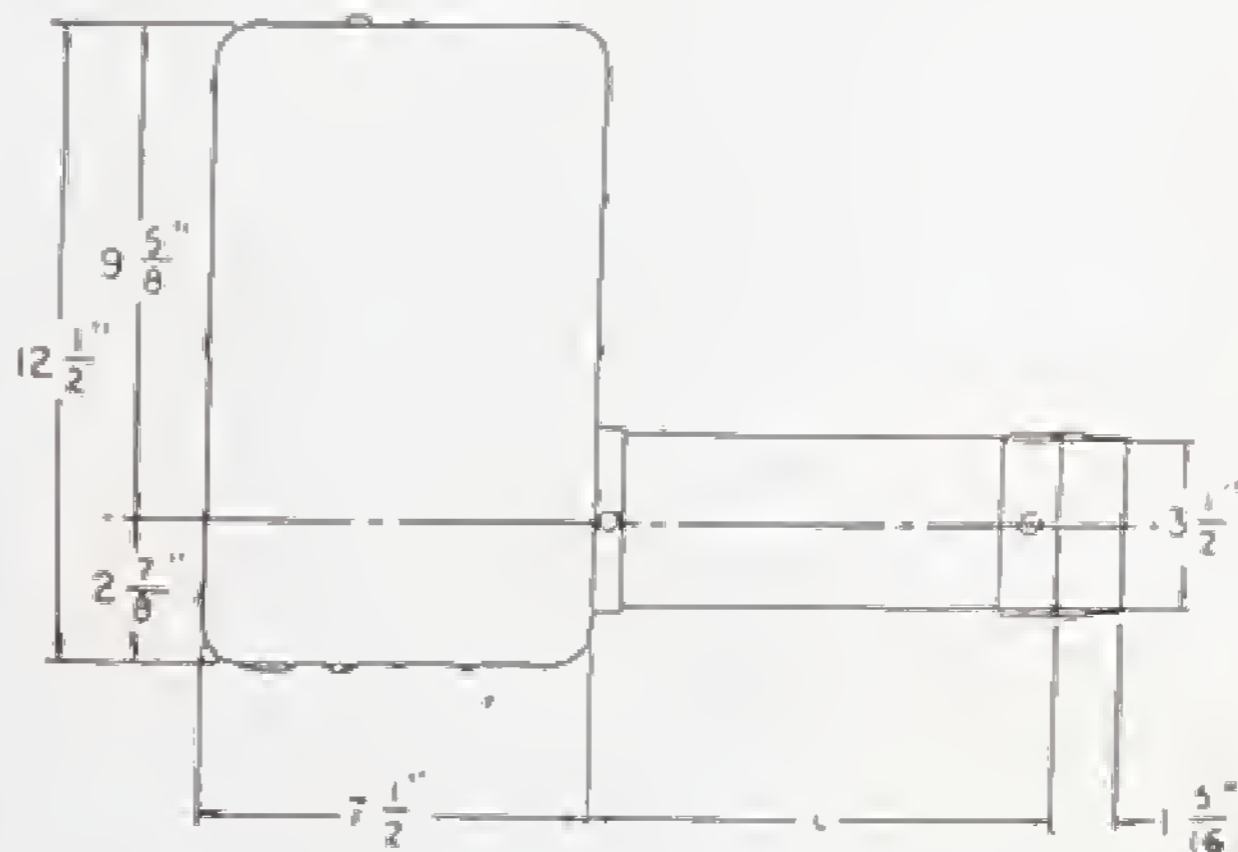

PLAN VIEW

FURTHER DETAILS AND ILLUSTRATIONS WILL BE SENT ON REQUEST.

BEESTON ROBIN HOOD SECTIONAL BOILERS

(For capacities, etc., see next page.)



Major.	Senior.	C Pattern.	New F Pattern.	General.	Junior.
--------	---------	------------	----------------	----------	---------

General and Junior Boilers can be supplied with Horizontal Pattern Doors.

We do not recommend boilers to be worked to their full capacity; a size larger than actually required should always be provided.

When Robin Hood Boilers are supplied for Oil Fuel or Automatic Stokers, without fire bars, an allowance is made for omission of bars.

ROBIN HOOD SECTIONAL BOILERS

Ratings

No. of Sections	JUNIOR Rating sq. ft.	GENERAL Rating sq. ft.	MONA Rating sq. ft.	NEW F PATTERN Rating sq. ft.
3	350	—	—	—
4	465	765	—	—
5	585	940	880	1,295
6	675	1,105	1,080	1,550
7	815	1,315	1,275	1,805
8	940	1,490	1,470	2,065
9	—	1,700	1,665	2,320
10	—	1,870	1,865	2,575
11	—	—	—	2,830
12	—	—	—	3,090

No. of Sections	C PATTERN Rating sq. ft.	SENIOR Rating sq. ft.	MAJOR Rating sq. ft.
5	1,685	—	—
6	2,025	3,060	4,205
7	2,365	3,600	4,950
8	2,705	4,150	5,695
9	3,045	4,700	6,440
10	3,390	5,240	7,175
11	3,730	5,800	7,980
12	4,070	6,330	8,665
13	4,410	6,900	9,405
14	4,750	7,420	10,150
15	—	—	10,900
16	—	—	11,635

The Mona Robin Hood Boiler has the smoke flue at the front.

Nos. 3B and 4B Juniors and Nos 4H and 5H Generals can be supplied with front smoke flue, if specially ordered.

The following Boilers are for Oil Fuel or Automatic Stoker and are not recommended for hand firing: Nos. 11 and 12FN; Nos. 13 and 14CN; Nos. 13 and 14N Senior and Nos. 13 to 16MN Major.

IDEAL BRITANNIA BOILERS

For Water—Hand-Firing



No. 2, with Jacket.
With Damper Regulator.



No. 3, without Jacket.
With Damper Regulator.

Details on next page.

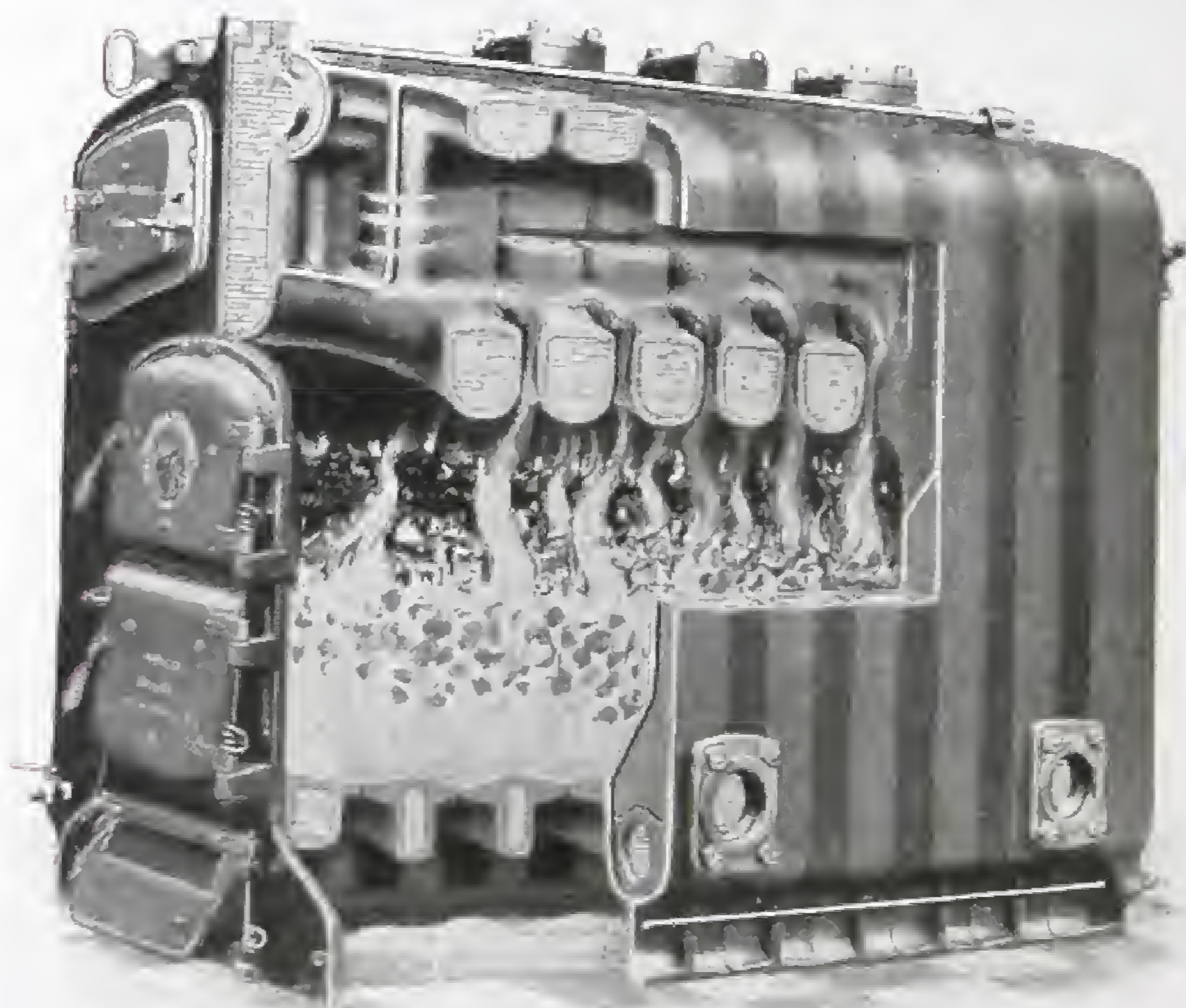

No. 4.
Cut. view.

IDEAL BRITANNIA BOILERS

For Water, Hand-Firing

No.	Ratings		Dimensions in			Flow and †Return Con- nections in.
	Direct Radiation sq. ft.	Lineal feet of 4 in. Pipe	Height to top of Flow Outlet	Width face to face of returns	Length	
24K	995	860	} 50 $\frac{1}{8}$	} 34 $\frac{7}{8}$	23 $\frac{1}{8}$	2-4
25K	1,250	1,080			29 $\frac{1}{8}$	2-4
26K	1,505	1,300			35 $\frac{1}{8}$	2-4
27K	1,760	1,520			41 $\frac{1}{8}$	3-4
28K	2,015	1,740			47 $\frac{1}{8}$	3-4
29K	2,270	1,960			53 $\frac{1}{8}$	3-4
35K	1,950	1,695	} 58 $\frac{13}{16}$	} 44	34 $\frac{3}{16}$	2-4
36K	2,365	2,050			41 $\frac{3}{16}$	2-4
37K	2,780	2,405			48 $\frac{3}{16}$	2-4
38K	3,195	2,760			55 $\frac{3}{16}$	3-4
39K	3,610	3,115			62 $\frac{3}{16}$	3-4
310K	4,025	3,470			69 $\frac{3}{16}$	3-4
311K	4,440	3,825			76 $\frac{3}{16}$	3-4
47K	3,905	3,370	} 67 $\frac{7}{8}$	} 54 $\frac{1}{2}$	48 $\frac{3}{16}$	2-4
48K	4,485	3,875			55 $\frac{3}{16}$	2-4
49K	5,065	4,380			62 $\frac{3}{16}$	3-4
410K	5,645	4,885			69 $\frac{3}{16}$	3-4
411K	6,225	5,390			76 $\frac{3}{16}$	4-4
412K	6,805	5,895			83 $\frac{3}{16}$	4-4
413K	7,385	6,400			90 $\frac{3}{16}$	4-4
414K	7,965	6,905			97 $\frac{3}{16}$	4-4

Insulating Galvanised Steel Jackets are available as an extra, when ordering, state position of connections.

Jacket and doors can be supplied in vitreous enamel finish; prices on application.

Jacket can be fitted after pipe connections have been made.

† No. 2 Britannia.—On special order, two 3-in. flanged return connections on face of back section can be provided. Distance from floor to centre 8 $\frac{7}{16}$ in.; centre to centre, 24 $\frac{5}{8}$ in.

No. 3 Britannia.—5-in. flanged flow and return connections can be supplied in place of the above. Two 4-in. flanged return connections on face of back section can be provided. Distance from floor to centre, 9 $\frac{3}{8}$ in.; centre to centre, 33 in.

No. 4 Britannia.—5-in. and 6-in. flanged flow and return connections can be supplied in place of above. For 6-in. connections an adapter is used, increasing height or width of boiler, 4 in.

Two 4-in. flanged return connections on face of back section can be provided. Height from floor to centre, 9 $\frac{3}{8}$ in.; centre to centre, 43 $\frac{1}{4}$ in.

Stoking Tools and Draw-off Cocks extra.

Diameter of Socket Smoke Outlet.—Nos. 24-29K, 8 in.; Nos. 35-38K, 10 in.; Nos. 39-311K, 12 in.; Nos. 47-411K, 12 in.; Nos. 412-414K, 14 in.

IDEAL BRITANNIA BOILER

For Water, Hand-Firing.

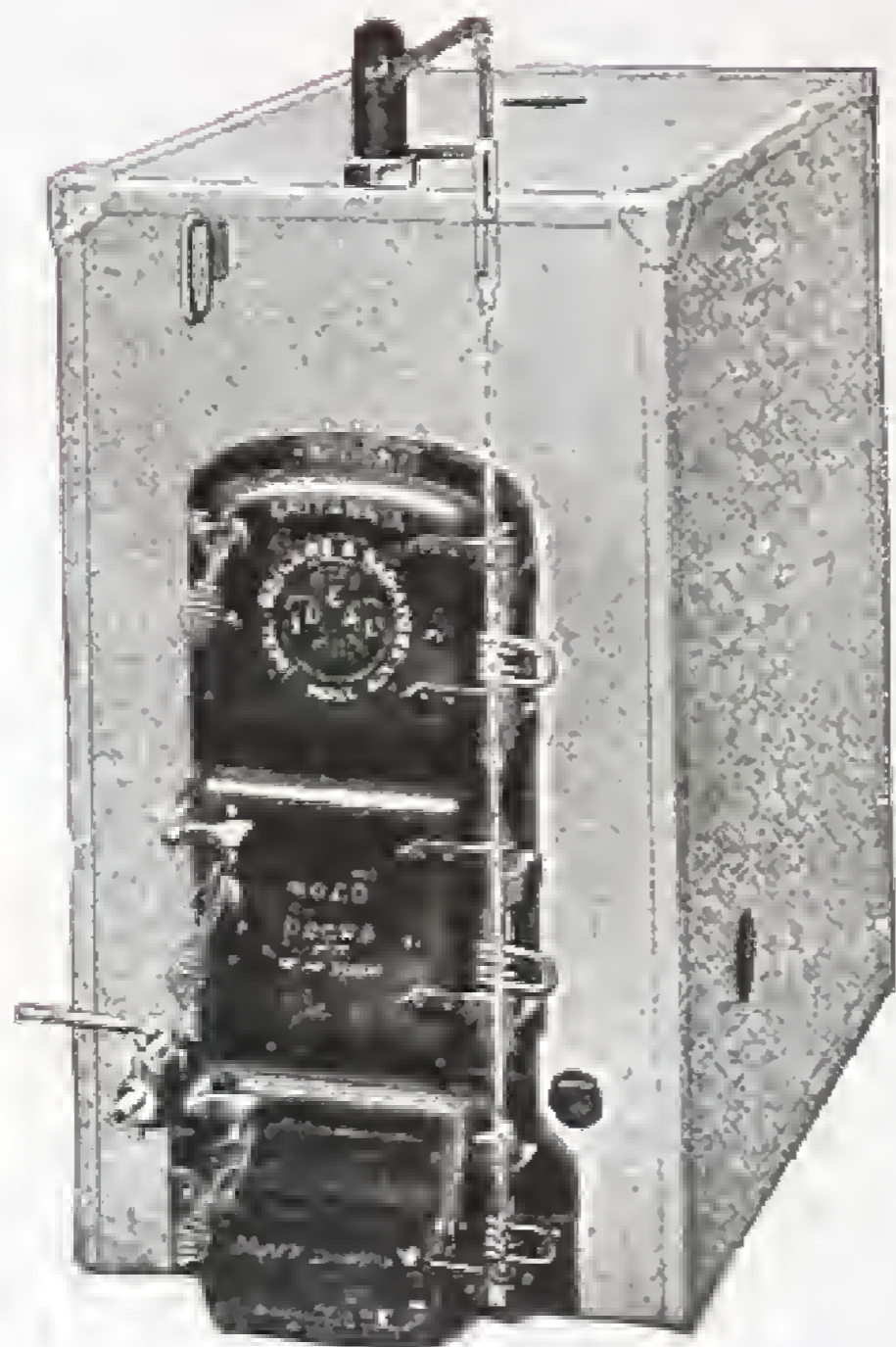

No. 0-K, with Insulating Jacket.
With Damper Regulator.



No. 0-KF, with Front Smokehood
— Without Jacket.

● *Details on next page.*



No. 1-K, with Insulating Jacket.
With Damper Regulator.



No. 1-KF, with Front Smokehood.
Without Jacket.

BAXENDALE & CO. LTD.

IDEAL BRITANNIA BOILER

For Water, Hand-Firing

No.	Heating Surface sq. ft.	Ratings		
		B.T.U. per hour	Direct Radiation sq. ft.	Lineal Feet of 4 in. Pipe
03K	9'0	40,000	245	215
04K	11'5	51,000	315	275
05K	14'0	62,000	385	335
06K	16'5	73,000	455	395
07K	19'0	84,000	525	455
14K	21'0	93,000	580	500
15K	26'5	117,000	730	630
16K	32'0	141,000	880	760
17K	37'5	165,000	1,030	890
18K	43'0	189,000	1,180	1,020

No.	No. of Sections	Height to top of Flow Outlet in.	Width of Boiler in.	Depth of Boiler in.	Diameter of Smoke Outlet in.	Tappings	
						Flow Outlets at top	Returns at Bottom either side
						No. and Diam. in in.	
03K	3	33	18 $\frac{3}{8}$	17 $\frac{1}{16}$	6	1-2	1-2
04K	4	33	18 $\frac{3}{8}$	23 $\frac{1}{16}$	6	1-2	1-2
05K	5	33	18 $\frac{3}{8}$	29 $\frac{1}{16}$	6	2-2	2-2
06K	6	33	18 $\frac{3}{8}$	35 $\frac{1}{16}$	6	2-2	2-2
07K	7	33	18 $\frac{3}{8}$	41 $\frac{1}{16}$	6	2-2	2-2
14K	4	39 $\frac{3}{4}$	24 $\frac{1}{16}$	23 $\frac{1}{16}$	8	1-3	1-3
15K	5	39 $\frac{3}{4}$	24 $\frac{1}{16}$	29 $\frac{1}{16}$	8	1-3	1-3
16K	6	39 $\frac{3}{4}$	24 $\frac{1}{16}$	35 $\frac{1}{16}$	8	1-3	1-3
17K	7	39 $\frac{3}{4}$	24 $\frac{1}{16}$	41 $\frac{1}{16}$	8	2-3	2-3
18K	8	39 $\frac{3}{4}$	24 $\frac{1}{16}$	47 $\frac{1}{16}$	8	2-3	2-3

* Jacket and doors can be supplied in vitreous enamel finish ; prices on application.
Jacket can be fitted after pipe connections have been made.

Extras : Draw-off Cock, $\frac{3}{4}$ in. No. 802 Ideal Damper Regulator.

When automatic regulation is not required, a sliding ashpit door can be supplied in place of the hinged pattern illustrated, if specified on order.

Grate Bars : Grill pattern.

Insulating Galvanized Steel Jackets are available as an extra, when Ordering state position of Connections.

If boiler is required with smokehood at front, add the letter F to Fig. Nos. thus : 03KF, 14KF, etc.

When fitted with smokehood at front, the height from floor to top of smoke outlet is, No. 0-K Series 37 $\frac{1}{16}$ in. ; No. 1-K Series 40 $\frac{1}{16}$ in.

LANCASTER · LEEDS · BLACKPOOL

BAXENDALE & CO. LTD.

BEESTON DOMESTIC BOILERS

For Hot Water Supply



Size	Outside measurements overall			Dia. of Smoke Pipe in.	B.T.U. per hour for Hot Water Supply	Capacity—Gals. per hour			
	H. in.	W. in.	D. in.			60° to 100°	60° to 130°	60° to 212°	
Open Type	WOF	20	18½	17¾	4	20,000	50	29	13
	OOF	23½	18½	18	4	23,500	59	34	15
	AOF	26¾	18½	18	4	28,500	71	41	19
	BOF	26¾	18	21½	4	37,500	94	54	25
	COF	26¾	19	25½	4½	55,000	133	76	35
	DOF	31½	23½	26¾	5	76,000	189	108	50
	TWOF	25	18½	18	5	20,000	50	29	13
	TOOF	26½	18½	18	5	20,000	50	29	13
Closed Type	PX	30	14½	14	4	35,750	81	46	21
	OX	32	16½	15¾	4½	47,650	108	62	28
	AX	34¾	18¾	17¾	4½	60,500	133	76	35
	CX	35	18	20½	5	82,500	189	108	50
	DX	40	21¾	21½	5	104,500	227	130	60
	EX	43	24¾	25	5	137,500	312	179	82
	FX	47 ⅞	24¾	27	6	170,500	388	222	102
	HX	48 ⅞	27¾	30	6	203,500	462	264	122

Extras : Ashpan, Tray with Feet, Polished Top, Nickel or Chromium-plated Top.

Polished Top is included in price of TWOF, OOF, TOOF. AOF and Standard WOF is supplied with black top.

All Beeston Open Fire Domestic Boilers can be supplied with Porcelain Enamel Finish.

Rustless (Bower-Barffed) Firepots Available to Special Order.

MILLER STREET · MANCHESTER

ROBIN HOOD ROYAL BOILERS



Royal Open Fire.

No. 1 Royal.

No. 2 Royal with Jacket,

RATINGS

No.	Heating Surface sq. ft.	To heat feet of 4 in. Pipe	To heat sq. ft. of Radiation	Heating Power British Thermal Units	Water Capacity Gallons	Smoke Pipe Size in.
3 ROF	8	210	240	38,400	6 $\frac{1}{2}$	5
4 ROF	10·9	283	327	52,300	7 $\frac{1}{2}$	5
5 ROF	13·2	342	396	63,360	8 $\frac{1}{2}$	5
6 ROF	15·5	402	465	74,400	9 $\frac{3}{4}$	5
3 RI	11 $\frac{1}{4}$	270	310	49,500	8	5
4 RI	14 $\frac{1}{4}$	340	390	62,700	9	5
5 RI	17 $\frac{1}{4}$	410	475	75,900	10	5
6 RI	20 $\frac{1}{4}$	480	560	89,100	11	5
32 RN	13 $\frac{2}{3}$	325	375	60,000	9 $\frac{1}{4}$	6
42 RN	18	425	495	79,000	10 $\frac{1}{2}$	6
52 RN	22 $\frac{1}{3}$	530	615	98,000	11 $\frac{3}{4}$	6
62 RN	26 $\frac{2}{3}$	630	735	117,000	13	6
72 RN	31	735	850	136,000	14 $\frac{1}{2}$	6

Jacket with or without Asbestos, Grey Enamel Finish, including Doors, Smoke Flue and Base.

ROF and No. 1—Firegrate—in two halves.

No. 2—Firegrate—Grill Pattern.

Boilers are available with galvanised jackets—with or without asbestos linings.

Boilers supplied with enamel jackets are without asbestos lining.

Jackets must be fitted before pipe connections are made.

Rocking Firegrate to special order.

Top-smoke outlet supplied unless otherwise ordered.

BAKENDALE & CO. LTD.

IDEAL NEO-CLASSIC BOILERS

For Heating and Indirect Hot Water Supply

Nos. 1A and 2A Series

No.	B.T.U. per hour	Rating	
		Direct Radiation sq. ft.	Heating Surface B.T.U. per hour
NC11A	11,000	145	4,500
NC14A	14,000	195	5,700
NC17A	17,000	245	6,900
NC20A	20,000	295	8,100
NC23A	23,000	345	9,300
NC26A	26,000	395	10,500
NC29A	29,000	445	11,700
NC32A	32,000	495	12,900
NC35A	35,000	545	14,100
NC38A	38,000	595	15,300
NC41A	41,000	645	16,500

No.	Number of Sections	Height in feet of Fire Chute	Width in in.	No. Flues including Smoke Laid	Thickness of Smoke Chute in in.	Tappings	
						Flow Chutes in feet	Return in feet
NC11A	1	34 1/2	11 1/2	11	4	1-2	1-2
NC14A	2	34 1/2	11 1/2	14	4	1-2	1-2
NC17A	3	34 1/2	11 1/2	17	4	1-2	1-2
NC20A	4	34 1/2	11 1/2	20	4	1-2	1-2
NC23A	5	34 1/2	11 1/2	23	4	1-2	1-2
NC26A	6	34 1/2	11 1/2	26	4	1-2	1-2
NC29A	7	34 1/2	11 1/2	29	4	1-2	1-2
NC32A	8	31	10 1/2	32	5	1-4	1-4
NC35A	9	31	10 1/2	35	5	1-4	1-4
NC38A	10	31	10 1/2	38	5	1-4	1-4
NC41A	11	31	10 1/2	41	5	1-4	1-4
NC44A	12	31	10 1/2	44	5	1-4	1-4

Available in Hot Water, Dry Matter or Crown, Muffle and Flue. Crown Flue, Girth Flue.

¹ Boiler extends up to 40 feet. ² Without Jacket

A Jacketing Cover, supported by a Detachable Lower Flue Stand through the Chimney Dues can be supplied in order for the No. 1A Series.

James Jackson Tools - Chimney Repairs - 100 Cook - 1 Unit No. Spring Street, Leeds.

Supplied with Vertical or Horizontal Installation.

MILLER STREET - MANCHESTER

IDEAL NEO-CLASSIC BOILERS

For Heating and Indirect Hot Water Supply



No. 1A Series



Without jacket, and with rocking grate lever in position.

Cream mottle vitreous enamelled jacket ; other parts as shown in black vitreous enamel.



No. 2A Series

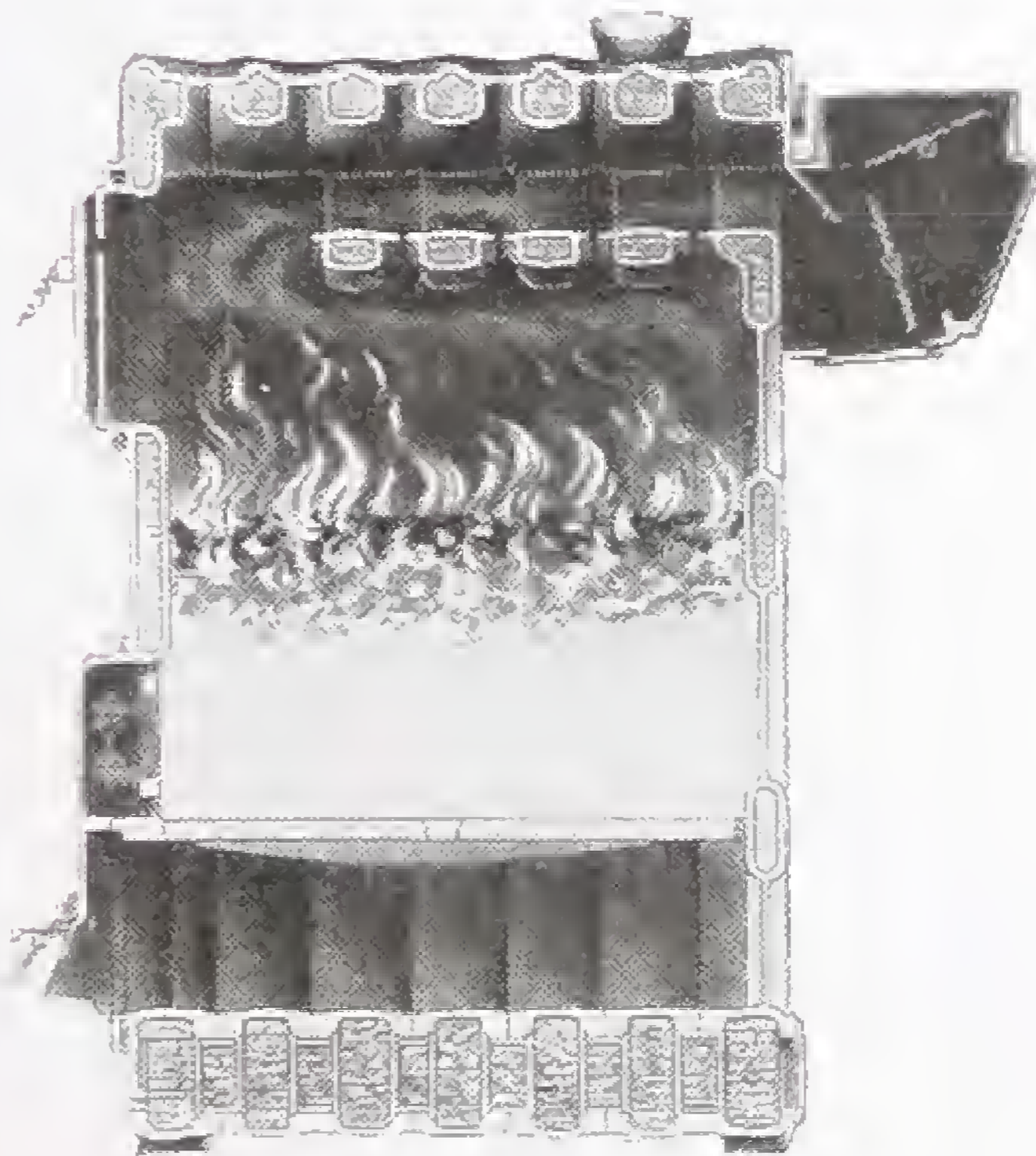

Sectional view, showing flue travel and waterways.

Cream mottle vitreous enamelled jacket ; other parts as shown in black vitreous enamel.

BAXENDALE & CO. LTD.

BEESTON BOILERS FOR GARAGES, GREENHOUSES, Etc.



Not Suitable for Domestic Supply.

This series of boilers has proved very popular, and many thousands have been sold. They are strong and durable, and boilers sold over thirty years ago are still working quite satisfactorily. Suitable for motor garages, greenhouses, etc. With smoke outlet at the front, the body of the boiler can be fixed inside the building and stoked from the outside. It can also be supplied with smoke outlet at the top. When properly banked up, the Beeston Boiler will easily burn through the night without attention.

Size	Outside measurements of Boiler			Inside measurements of Firebox			Position of Smoke Outlet and diam.	To heat sq. ft. direct Radiation	To heat feet of 4 in. Pipe
	H. in.	W. in.	D. in.	H. in.	W. in.	D. in.			
OB	21	15½	13½	14½	8	9	Front 4	50	25
OA	21	15½	13½	14½	8	9	Top 4	50	25
A	24	15	15	16½	10½	12	Front 4½	100	40
AA	24	15	15	16½	10½	12	Top 4½	100	40
*A1	24	15	15	16½	10½	12	Front 4½	120	60
*A2	24	15	15	16½	10½	12	Top 4½	120	60
A3	27	15	15½	19½	10½	12½	Front 4½	160	90
A4	27	15	15½	19½	10½	12½	Top 4½	160	90
B1	27	16	19	16½	11	16½	Front 5	190	130
B2	27	17½	20½	16½	12½	16½	Top 5	190	130
C	31	17	20	20	11	17	Front 5	230	200
C2	31	17	20	20	11	17	Top 5	230	200
D	36½	20	20	24	14	18	Front 5	290	280
D2	36½	20	20	24	14	18	Top 5	290	280

* These boilers are same size as A and AA patterns, but with waterway back extended to level of firebars. B1, B2, C, C2, D and D2 patterns have part waterway front. The ratings in square feet radiation apply to boilers used for house heating; the column showing 4-in. pipe is for greenhouse and garage boilers.

MILLER STREET · MANCHESTER

IDEAL DOMESTIC BOILERS

For Hot Water Supply



No. 14D. With Baseplate and Damper Regulator. No. 15D. Cut View. With Baseplate

No.	Hot Water Supply only			Heating only		
	B.T.U. per hour	** Gallons per hour			B.T.U. per hour	Direct Radiation Sq. ft.
		40°-120°	40°-140°	40°-160°		
14D	99,000	123	99	82	34,800	215
15D	132,000	165	132	110	53,500	335

Rustless (Bower Barffed) firepots available to special order.

When automatic regulator is required a No. 802 Ideal Damper regulator is provided. Stoking Tools and Baseplate are available as extras.

No.	Diameter of Boiler Baseplate in.	*Height to Top of Smoke Outlet in.	Diameter of Smoke Outlet in.	*Height to Centre of Flow in.	*Height to Centre of Return in.	Tapping Flow and Return in.
14D	25½	48	4½†	35¼	9¼	2-2
15D	28	51 7/16	6	38½	9½	2-2

* Including Baseplate (No. 14D, 2½ in.; No. 15D, 2½ in.).

** Gallons per hour at any temperature can readily be determined by dividing the B.T.U. rating by the temperature rise multiplied by 10.

Smokepipe and Elbows should not be less than size of smoke outlet.

Where independent cast-iron chimney is used, 6-in. is minimum size.

4½-in. by 6-in. Adapter for making 6-in. flue connection extra.

BAXENDALE & CO. LTD.

THE NEW BEANCO CAST-IRON INDEPENDENT BOILER



Size No.	Body	Total Height	Approx. Heating Power in 4-in. Pipes	Size of Flue Outlet
	in.	ft. in.	ft.	in.
1	8 x 12	2 8½	40	4
2	12 x 12	3 0½	60	5
3	16 x 12	3 4½	80	5

The body sizes are dimensions of Cylindrical Shell not including Top and Bottom Castings.
 The body is made in sections, so that any section can be replaced without necessitating a new Boiler.
 All boilers are tapped for ½ in. Draw-off. The size of Flow and Return Connections are for No. 1 size ½ in. Screwed, and on Nos. 2 and 3 size ¾ in. Screwed.

THE MANCHESTER WELDED BOILER

Made from Best British Manufactured Mild Steel Boiler Plates.

Size No.	Dimensions	Approx. Heating Power in 4-in. Pipes	Size of Tapped Bores	Size of Flue Outlet
	in.	ft.	in.	in.
1	18 x 14 x 14	30	1½	5
2	24 x 14 x 14	110	1½	5
3	30 x 14 x 14	150	1½	5
4	40 x 16 x 14	160	1½	5
5	34 x 16 x 14	200	1½	5
6	40 x 16 x 14	250	1½	5
7	46 x 16 x 14	300	1½	5
8	40 x 20 x 16	300	2	6
9	34 x 20 x 16	350	2	6
10	40 x 20 x 16	400	2	6
11	46 x 20 x 16	450	2	6
12	38 x 26 x 20	550	2	7
13	40 x 26 x 20	650	2	7
14	46 x 26 x 20	750	2	7
15	40 x 30 x 20	900	2	7
16	48 x 30 x 20	1,000	2	7



This illustration shows Boiler fitted with Screwed Connections for Flow and Return at Right and Left-hand sides and Fig. 2 Pattern Top Draw-off Tap extra.

The measurements given above are exclusive of Top and Bottom Castings.

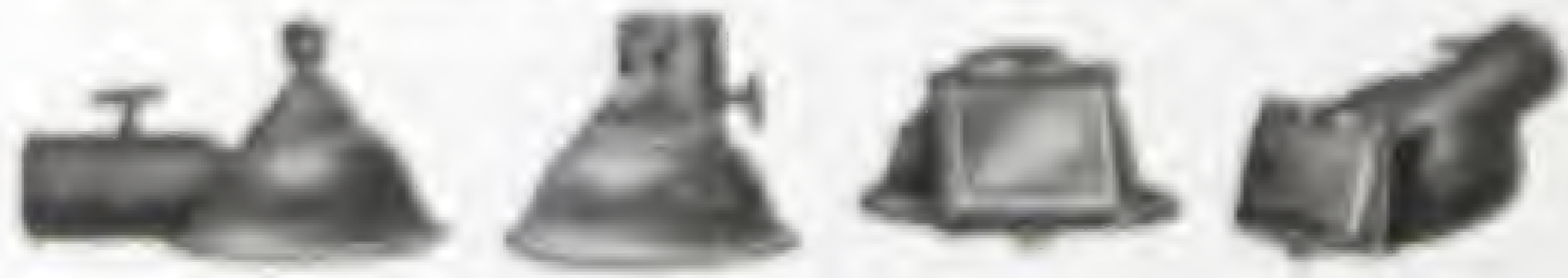

Fig. 1 Fig. 2 Fig. 3 Fig. 4

To save delay please specify which Pattern of Top is required, also size and position of Connections.

Unless otherwise ordered Manchester Boilers are supplied with Connections for Wrought-iron Tube.

The screw Connections can be placed at the back or sides as preferred. Sockets for Cast-iron Pipe can be supplied on these Boilers if specially ordered without extra charge. Boilers are prepared for Draw-off Tap. Tap extra.

MILLER STREET · MANCHESTER

THE CULTIVATUM BOILER

For Greenhouses, Garages, etc. All Boilers are fitted with Damper and are also provided with $\frac{1}{2}$ -in. hole for emptying.

No.	Height Overall	Boiler Body only		
		Height	Width	Depth
	in.	in.	in.	in.
1	22	20	16	10
2	27	25	16	10
3R	30	28	16	12
4	30 $\frac{1}{2}$	28	16	16 $\frac{1}{2}$

No.	Smoke Pipe Size	Heating Capacity in 4-in. Pipes
1	4	70
2	4 $\frac{1}{2}$	95
3R	4 $\frac{1}{2}$	135
4	5	175



Boilers in stock include as standard two 4-in. Expansion Joint Connections at back. Two 2-in. or 3-in. Connections, or two Screwed Holes, can be supplied if required at an extra cost. Socket connections can be substituted at an extra cost.



No. FA 302

HORTICULTURAL AND AGRICULTURAL THERMOMETERS

8 in. Zinc scale maximum and minimum registering Thermometer, Range 10/130° Fahr., mounted in White Japanned Iron Case with Magnet for Resetting Indices.

No. FA 303
PIPE LINE AND SURFACE THERMOMETERS

With a view both to conserving fuel and ensuring efficiency in operation, the use of a ROTOTHERM pipe line thermometer in any hot water or boiler system is indispensable. Two types are available for farm and dairy use. Both have a 2 $\frac{1}{2}$ in. dial, clear open scale and a choice of temperature ranges. One is for insertion in the pipe line with a fixed boss screwed for $\frac{1}{2}$ in. B.S.P., and is available in three standard $\frac{5}{16}$ in. diameter stem lengths of 1 $\frac{3}{4}$ in., 2 $\frac{1}{4}$ in. and 3 in., whilst the other is for external fitment (as shown) by means of a spring or jubilee clip to suit pipes of 1 in. to 6 $\frac{3}{4}$ in. outside diameter.

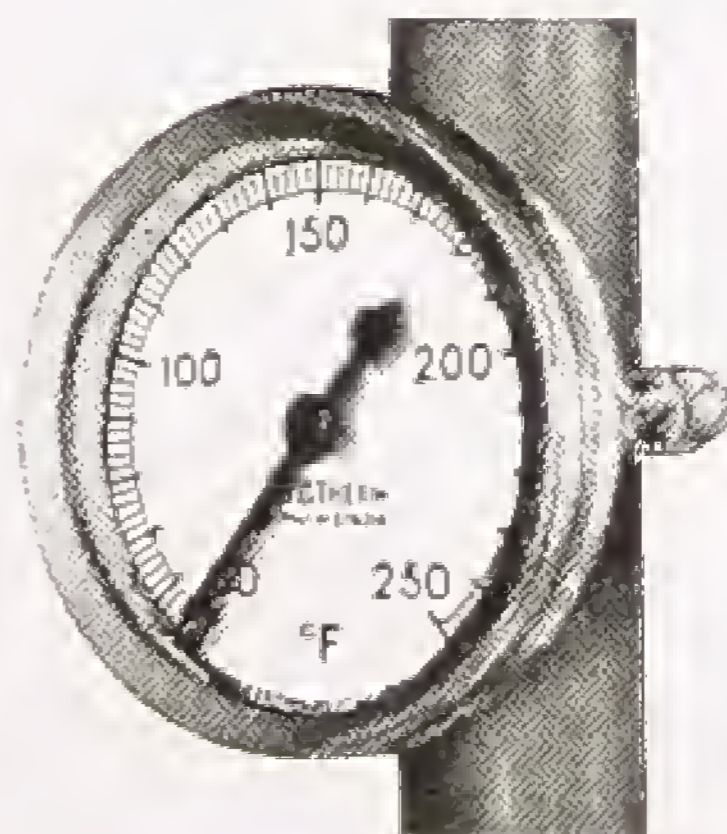

HEATING STOVES

SLOW COMBUSTION STOVE
No. H 3392

Complete with Reversible Nozzle and Loose Ashpan.
Maximum of Heat with a Minimum of Fuel.
Best Quality Sheet Steel Body.

Best Brick-lined throughout. Cast-iron Top and Bottom.

Size No.	0	1	2	3	4	5
Diameter	8	9	10	12	14	16 in.
Height	16	20	25	30	32	36 in.
Nozzle	3½	3½	3½	4	4	5 in.

Approximate Heating

Capacity	1,500	2,000	7,000	12,000	15,000	20,000
	cu. ft.					

Tray Fenders are extras, and are not supplied unless ordered.



THE "IMPROVED BOGIE"
No. H 67

Cast-iron, with sectional body, brick-lined fire chamber, hinged fire door, boiling opening, draw-out ashpan, sliding regulator and tray.

REVERSIBLE FLUE OUTLET TOP OR BACK

Size No.	Overall Width	Overall Height	Flue Nozzle	Average Heating Capacity cu. ft.
12	13½	19½	3½ in.	2,000

Standard Finish. White/Grey Bonamel Finish. Supplied plain or White/Grey Bonamel Finish. Other colours Tan, Terra Cotta, and Green. Combined draught regulator and cleaning door recommended for Bonamelled stoves to prevent damage by overheating.

THE "ROMESSE" STOVE
No. H 3395

Specially Suitable for Workshops.

No.	Approximate Heating Capacity cu. ft.	Height overall in.	Diameter of Body in.	Size of Pipe in.
0	6,000	27½	14	4
1	12,000	32	16	5
2	14,500	36	16	5
3	17,000	40	16	5
4	20,000	41	16	5
5	23,000	45	16	5
6	26,000	49½	16	5

Extras

Circular Galleries, 28 in. diameter (these Galleries are not available for No. 0 size).

Heavy Cast-iron Tray, 39½ in. diameter for sizes Nos. 1-6.

Smaller Cast-iron Tray for No. 0.



DIMPLEX PRESSED STEEL WATER RADIATORS

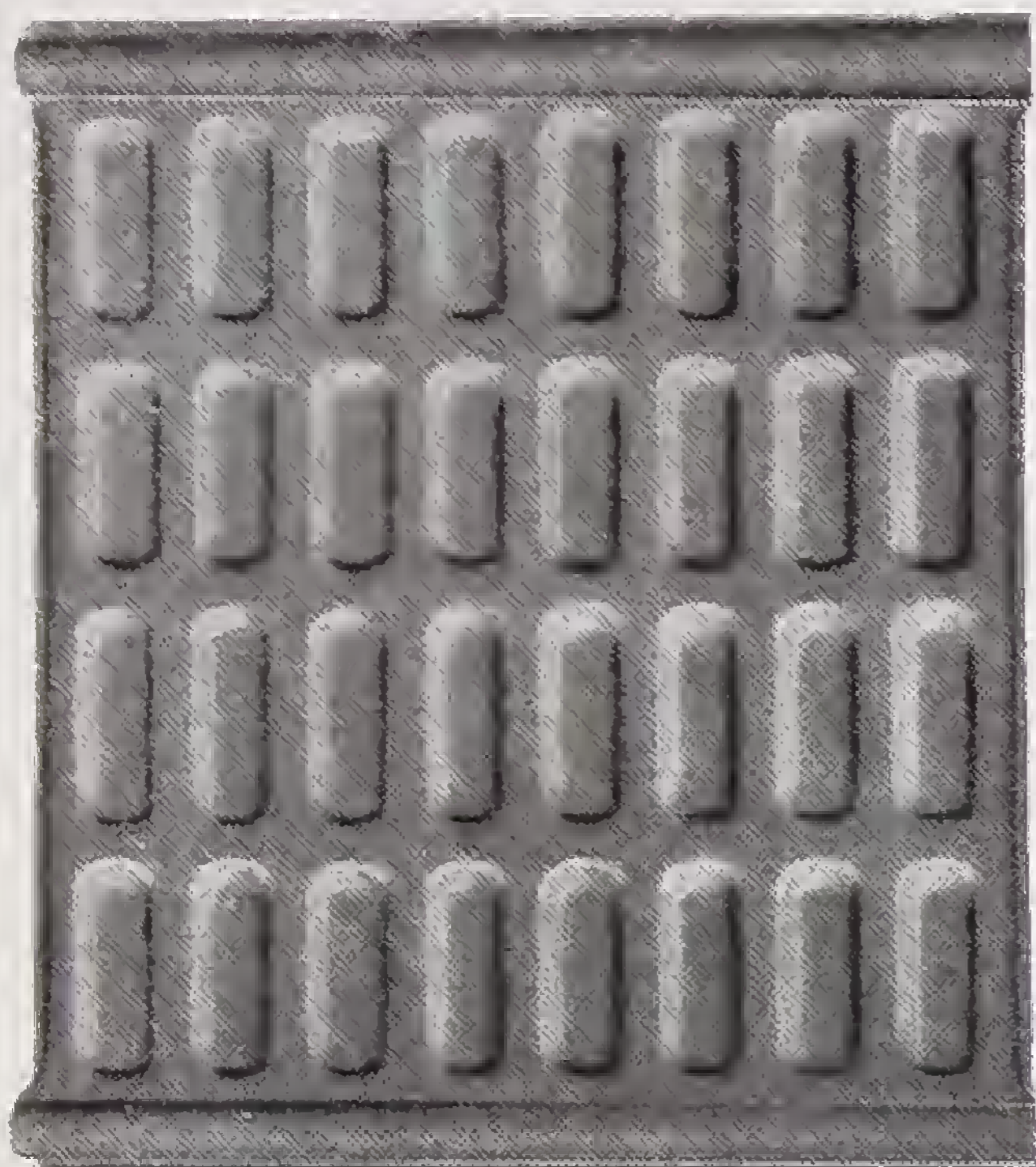

Dimplex Pressed Steel Water Radiators with their attractive yet unobtrusive styling harmonise with any decor, period or contemporary, and at the same time satisfy the most stringent demands for *balanced* space heating in varying situations. Whether for home, office, shop, club, hotel, school or for a host of other locations, Dimplex will provide comfort heating at its best and

their appearance will give constant pleasure.

MODELS

Model No.	No. of sections	Length (add 1" for Plug and Bushings)	Height	Heating surface sq. ft. (approx.)	Tappings B.S.P.
W.44	1	12"	26 ³ / ₈ "	5	1 ¹ / ₂ "
W.36	1	17 ¹ / ₄ "	20 ³ / ₄ "	6	1 ¹ / ₂ "
*W.38	1	22 ¹ / ₂ "	20 ³ / ₄ "	7 ¹ / ₂	2 ³ / ₄ "
*W.310	1	27 ¹ / ₂ "	20 ³ / ₄ "	10	3 ³ / ₄ "
*W.48	1	22 ¹ / ₂ "	26 ³ / ₈ "	10	4 ³ / ₄ "
*W.412	1	33 ¹ / ₄ "	26 ³ / ₈ "	15	4 ³ / ₄ "
*W.316	2	46"	20 ³ / ₄ "	15	4 ³ / ₄ "
*W.416	2	46"	26 ³ / ₈ "	20	4 ³ / ₄ "
*W.320	2	56 ³ / ₈ "	20 ³ / ₄ "	20	4 ³ / ₄ "
*W.424	2	67"	26 ³ / ₈ "	30	1"
W.330	3	83 ¹ / ₂ "	20 ³ / ₄ "	30	1"

*Top plates in all colours available for models asterisked.

COLOURS. Standard Finish—Light Bronze. To order: Gold, Cream, White, Sky Blue, Silver Grey, Eau-de-nil and Pink, at extra cost.

INSTALLATION

It is most important to note that Dimplex Water Radiators are only intended for use on an Indirect system, or in conjunction with a Calorifier. No guarantee can be given if they are connected direct to a domestic hot water system, in view of the varying properties of water and the different methods of installation.

IDEAL NEO-CLASSIC RADIATORS

For Water or Steam



For
Wrought
Iron Tube
and
Fittings
see pages
128 and 129



Suitable for steam pressures up to 20 lb. sq. in.

No. 2, width 24 in.

No. 4, width 51 in.

Pattern	Height in.	*Length per Section in.	Width at Feet in.	Floor to centre of top opening in.	Floor to centre of bottom opening in.	Heating surface per section sq. ft.
No. 2	30	2	24	28 1/2	2 1/2	1 1/2
	24			22 1/2		1
	18			16 1/2		1/2
No. 4	36	4 1/2	51	35	5 1/2	3 1/2
	30			29 1/2		2 1/2
	24	2		23 1/2	3 1/2	1 1/2
	18			17 1/2		1/2
No. 6	36	4 1/2	69	35	5 1/2	3 1/2
	30			29 1/2		2 1/2
	24	2		23 1/2	3 1/2	1 1/2
	18			17 1/2		1/2

* End sections 8 in. less. Add 2 in. to length of radiator for bushings and plugs.

Fitted with Ideal Vent Plug

Can be supplied without feet. Nos. 4 and 6 can be supplied with solid high legs to give 6 in. or 8 in. centres.

State in order if required for Steam.

IDEAL NEO-HOSPITAL RADIATORS

For Water or Steam



For
Radiator
Valves
and
Fittings

see pages
176 and 178



Suitable for steam pressures up to 20 lb. sq. in.

4-in. width.

5 1/2-in. width.

Pattern	Height in.	*Length per Section in.	Width at feet in.	Floor to centre of top opening in.	Floor to centre of bottom opening in.	Heating Surface per Section sq. ft.
4 inch	30	2	3	28 ⁵ / ₁₆	4	2 ¹ / ₁₆
	24			22 ⁵ / ₁₆		1
	18			16 ⁵ / ₁₆		1/2
5 1/2 inch	36	2 1/2	5 1/2	34 ⁵ / ₁₆	4	3 ¹ / ₁₆
	30			28 ⁵ / ₁₆		2 1/2
	24			22 ⁵ / ₁₆		2
	18			16 ⁵ / ₁₆		1 1/2
7 1/2 inch	40	2 1/2	7 1/2	34 ⁵ / ₁₆	4	4 ¹ / ₁₆
	30			28 ⁵ / ₁₆		3 ¹ / ₁₆
	24			22 ⁵ / ₁₆		2 1/2
	18			16 ⁵ / ₁₆		1 1/2

* End sections 1/2 in. less. Add 1 in. to length of radiator for bushings and plugs.

Fitted with Ideal Vent Plug.

Can be supplied without feet. The 5 1/2-in. and 7 1/2-in. widths can be supplied with solid high legs to give 6-in., 8-in., or 10-in. centres.

State on Order if Required for Steam.

BEESTON HOSPITAL RADIATORS

All plain surface with no dust receptacles.

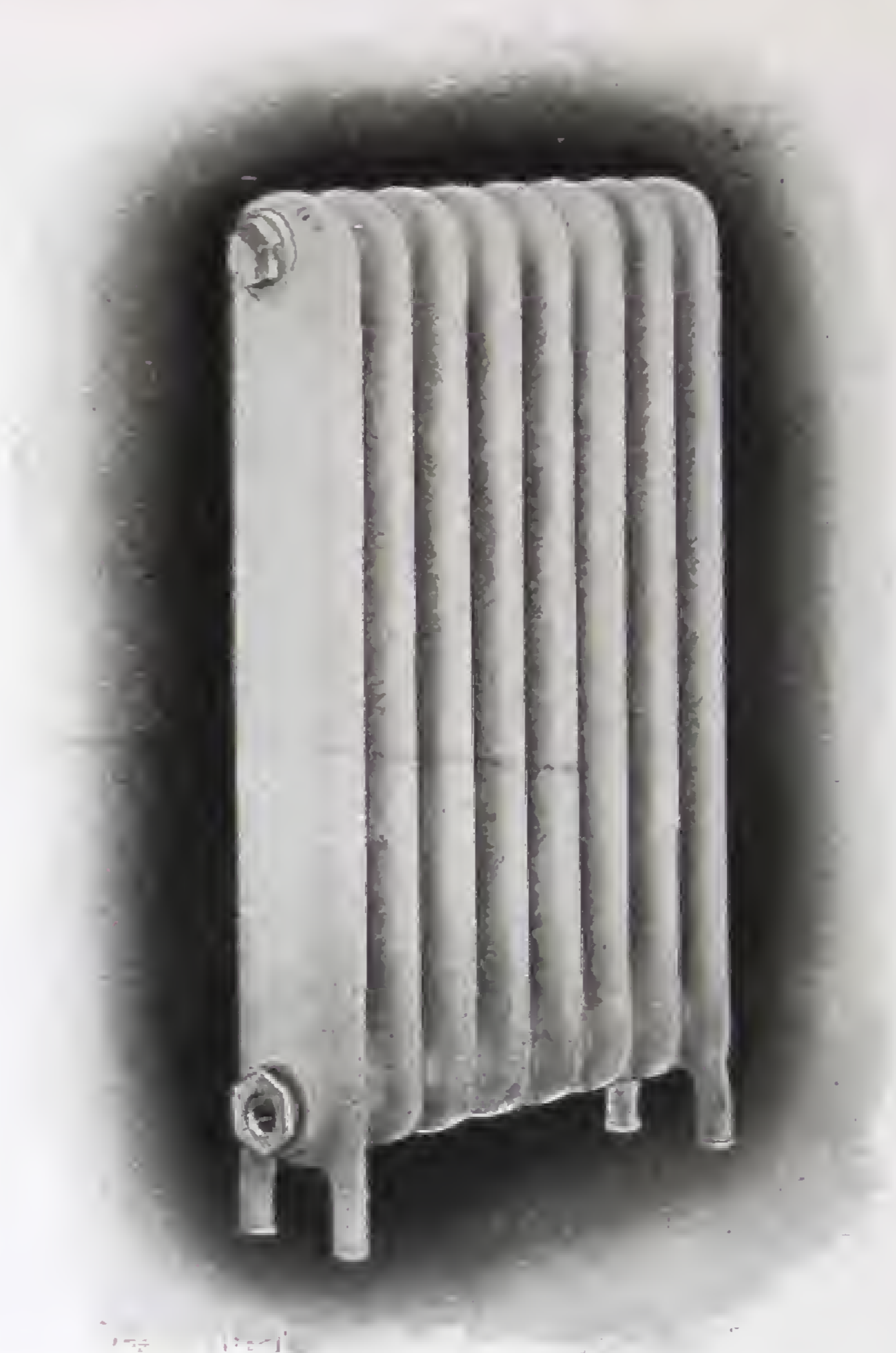

Space between sections = $1\frac{1}{4}$ in. for 5 in. and 7 in. wide; 1 in. for $3\frac{1}{2}$ in. wide.

For overall length of radiator, add 1 in. for bushings.

Pattern	Height	Length per Section	Width at Feet	Heating Surface per Section
	Inches	Inches	Inches	Sq. Feet
$3\frac{1}{2}$ in. wide	30	2	$3\frac{1}{2}$	$1\frac{3}{5}$
	24			$1\frac{1}{4}$
	18			1
5 in. wide	36	$2\frac{1}{4}$	5	$2\frac{3}{5}$
	30			$2\frac{1}{5}$
	24			$1\frac{3}{4}$
	18			$1\frac{2}{5}$
7 in. wide	36	$2\frac{1}{2}$	7	$3\frac{3}{5}$
	30			3
	24			$2\frac{1}{4}$
	18			$1\frac{3}{4}$

Can be supplied without feet, if so ordered.

Water Radiators are tapped for $\frac{1}{2}$ in. air cock, or can be fitted with CI airlet plug, free when so ordered.

BEESTON NEW ROYAL RADIATORS

Specially suitable for private house work, being light in appearance. Effective heating surface. Every part can be easily cleaned. All surfaces quite plain—no dust receptacles.



Pattern	Height	Length per Section	Width at Feet	Heating Surface per Section
	Inches	Inches	Inches	Sq. Feet
Two Column 3½ in. wide	30	2¼	3½	1⅔
	24			1⅓
	18			1
Three Column 5½ in. wide	36	2¼	5½	3
	30			2½
	24			2
	18			1½
Four Column 7½ in. wide	36	2¼	7½	3 ⁹ / ₁₀
	30			3 ¹ / ₅
	24			2 ³ / ₅
	18			1 ⁹ / ₁₀
Five Column 9½ in. wide	36	2¼	9½	5
	30			4 ¹ / ₁₀
	24			3 ¹ / ₅
	18			2 ² / ₅
	13			1 ³ / ₄

Water Radiators are tapped for ⅛ in. air cock, or can be fitted with CJ airlet plug, free, when so ordered.

Each section measures 2¼ in. from centre to centre.

For overall length of radiator, add 1 in. for bushings.

Made in any number of sections from 3 to 24.

Space between sections = 1¼ in.

Can be supplied without feet, if so ordered.

ROYAL WALL RADIATOR



2 Sections.

18 in., 24 in. and 30 in. high \times 2 $\frac{1}{4}$ in. wide, without feet. Each section 16 in. long. Heating surface per section, 18 in. high = 5 sq. feet ; 24 in. high = 6 $\frac{1}{2}$ sq. feet ; 30 in. high = 8 sq. feet.

Made in any number of sections from 1 to 10. Add 1 in. to length of each radiator for bushings.

BEESTON WALL RADIATOR

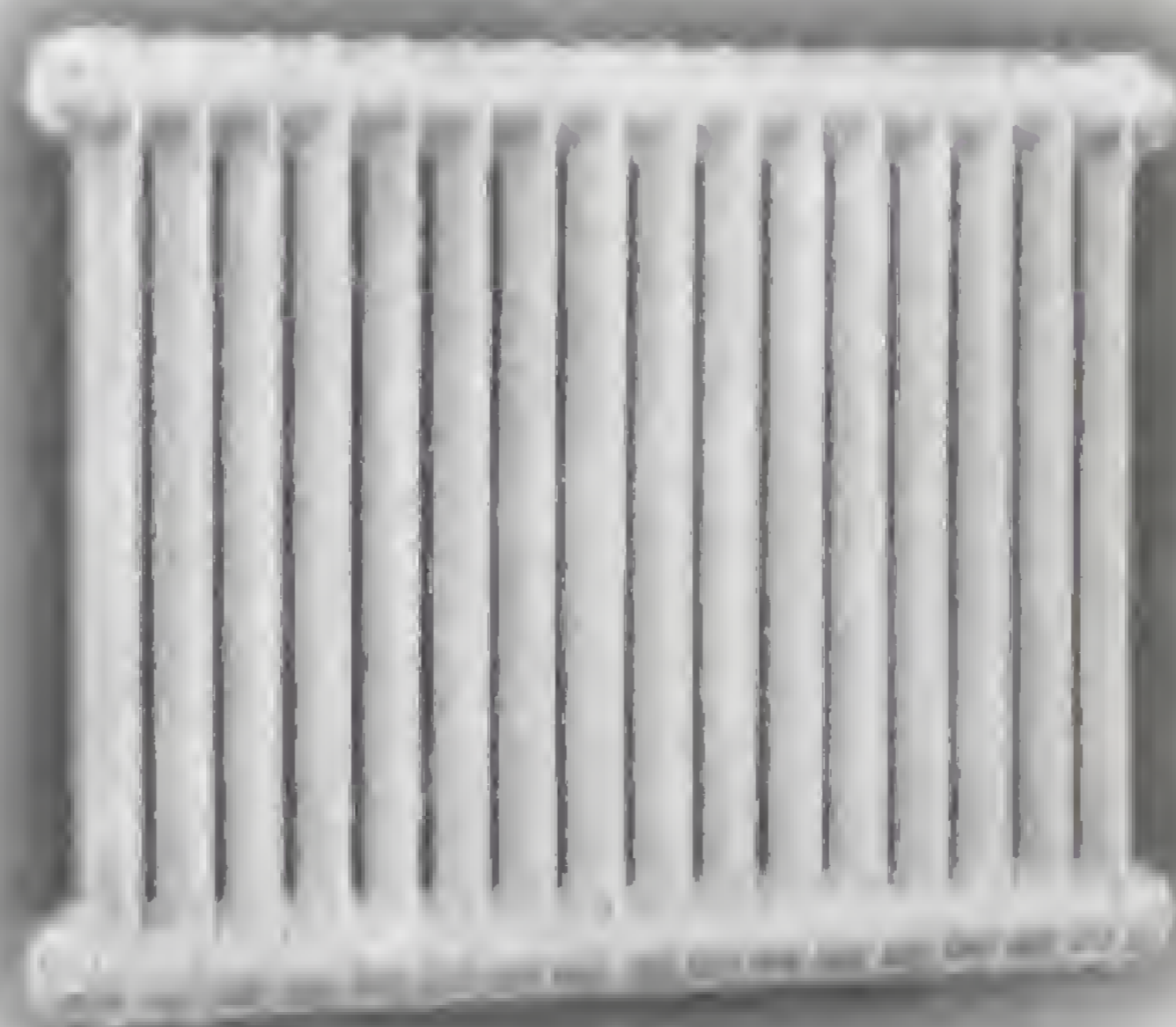

2 Sections.

14 $\frac{1}{2}$ in. and 22 $\frac{1}{2}$ in. high \times 2 $\frac{1}{2}$ in. wide, without feet. Length per section, 14 $\frac{1}{2}$ in. high = 22 $\frac{3}{8}$ in. ; 22 $\frac{1}{2}$ in. high = 14 $\frac{1}{8}$ in. Heating surface per section, 14 $\frac{1}{2}$ in. high = 8 sq. feet ; 22 $\frac{1}{2}$ in. high = 7 $\frac{1}{2}$ sq. feet.

Made in any number of sections from 1 to 10. Add 1 in. to length of each radiator for bushings.

Water Radiators are tapped for $\frac{1}{2}$ in. air cock, or can be fitted with CI airlet plug free when so ordered.

IDEAL CLASSIC WALL RADIATORS

For Water or Steam



Suitable for steam pressure up to 20 lb. sq. in.

Height	in.	30	24	18
*Length	"	16	16	16
Width	"	2	2	2
Heating Surface per section	sq. ft.	8 $\frac{1}{4}$	6 $\frac{2}{3}$	5

* Add 1 in. for bushings and plugs. When despatched in two or more pieces add $\frac{3}{4}$ in. for each hexagonal nipple.

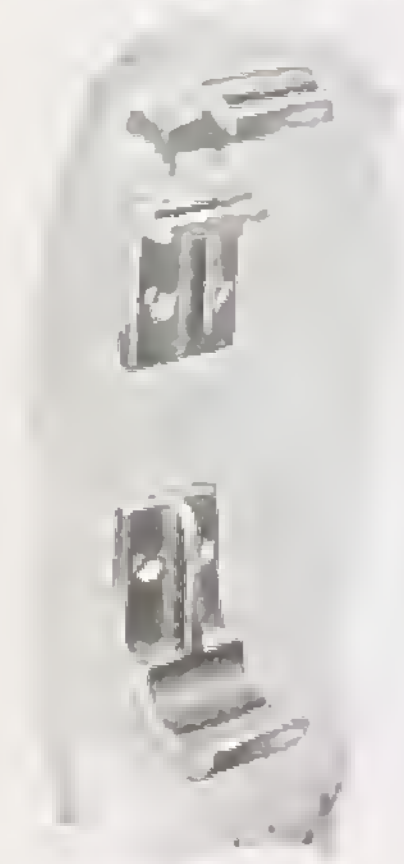

IDEAL CLASSIC WALL RADIATOR BRACKETS

Type "C" for wood screws.

Distance from wall to centre of tappings, 2 in.

IDEAL NEO-CLASSIC WINDOW RADIATORS

For Water or Steam



Height	13 in.
Width	13 $\frac{1}{8}$ in.
*Length per section	2 $\frac{1}{4}$ in.
Heating Surface, per section	2 $\frac{1}{2}$ sq. ft.

Fitted with Ideal Vent Plug

* End sections $\frac{1}{8}$ in. less.
Add 1 in. for bushings and plugs.

State on Order if Required for Steam.

HOT-WATER PIPES AND FITTINGS
With Sockets for Caulking.



1



BAXENDALE & CO. LTD.

HOT-WATER PIPES AND FITTINGS

With Sockets for Caulking.

(Illustrations on previous page)

No.	Size: 4 in.	1 in.	4 in.
1	Socket and Spigot Pipe, 1 ft. long		
		6 ft. long	
			2 ft. long
2	Socket and Spigot Elbow		
3	" " " " and Radius		
4	" " " " and Radius		
5	Double Socket Elbow		
6	" " " " and Radius		
7	" " " " and Radius		
8	" " " " and Radius		
12	Double Socket, Oblique Elbow		
13	Double Socket, Oblique Elbow, and Radius		
15	Socket and Spigot, Oblique Elbow		
16	Socket and Spigot, Oblique Elbow and Radius		

No.	Size: 4 in.	4 in.	4 in.
18	Diminishing Elbow, Socket and Spigot		
19	Diminishing Elbow, Socket and Spigot, and Radius		
20	Diminishing Elbow, Double Socket		
21	Diminishing Elbow, Double Socket and Radius		

No.	Size: 4 in.	4 in.	4 in.
22	Double Band Socket and Spigot, 4 in. pipe		
	Double Band Socket and Spigot, 4 in. pipe		

No.	Size: 4 in.	4 in.	4 in.
23	Double Band Socket and Spigot, 4 in. pipe		
25	5 Pipe, 2 Sockets, 4 in. pipe		
		5 in. pipe	
			4 in. pipe
30	Spigot, close		
31	" " open		
32	Three-way		
33	" Four-way		
35	" Spigot Outlet		
36	" Socket Outlet		
37	" Spigot Outlet, Three-way		
38	" Socket Outlet, Three-way		
39	" Spigot Outlet, Four-way		
40	" Socket Outlet, Four-way		
41	Blind Spigot		
41a	Blind Spigot, drilled and reamed, and run up to 4 in.		
42	Blind Socket		
42a	Blind Socket, drilled and reamed, and run up to 4 in.		
43	Stubby Collar		
44	Double Socket		
46	H Pipe close		
50	Branch Pipe, 2 Sockets, 1 Spigot		
51	" " 2 Sockets, 1 Socket		
52	" " 1 Socket		
53	" " Three-way		
54	Y Pipe		
57	Branch Y Pipe		

LIVERPOOL · EDINBURGH · DUBLIN

HOT-WATER PIPES AND FITTINGS
With Sockets for Caulking



BAXENDALE & CO. LTD.

HOT-WATER PIPES AND FITTINGS
With Expansion Joint Connections.



1 X



2 X



2 X



3 X



4 X



22 X

10 X



6 X

7 X



5 X

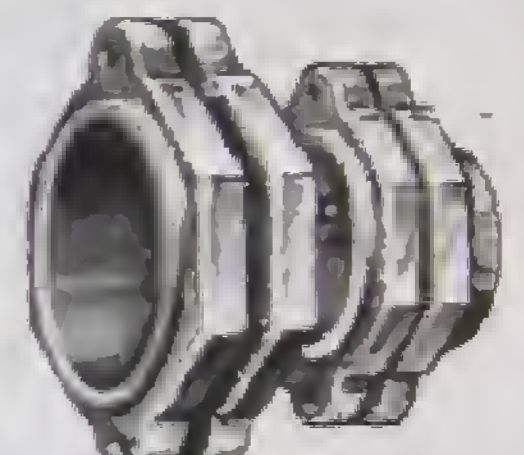

5 X X



11 X



12 X



13 X



16 X



18 X



20 X



20 X X

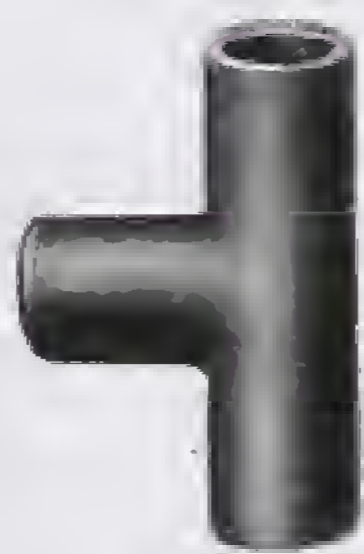

21 X



24 X



28 X



31 X



48 X



49 X



50 X



105 X

MILLER STREET · MANCHESTER

HOT-WATER PIPES AND FITTINGS

With Expansion Joint Connections

(Illustrations on previous page.)

Sizes : 2 in., 3 in., 4 in.

- 1x Expansion Pipe, 3 ft. long.
- " " 6 ft. long.
- " " 9 ft. long.

- 2x Expansion Joints complete with Rubber Rings and Bolts.

- 3x Inner Ring.

- 4x Flange.

- 5x Blank End Joint with Rubbers and Bolts.

- 5xa Blank End Joint Drilled and Tapped any size up to 2 in.

Sizes : 3 x 2 in., 4 x 2 in., 4 x 3 in.

- 5xx Diminishing Joint.

Sizes : 2 in., 3 in., 4 in.

- 6x Elbow, Ordinary.

- 7x " 2nd Radius.

- 10x " lengthened 9 in. at one end.

- 11x Elbow, Obtuse.

- 12x " Obtuse, outside.

- 13x Branch Pipe.

- 16x Double Bend, 4½ in. projection.

Double Bend, 7 in. projection.

Sizes : 2 in., 3 in., 4 in.

- 16x Double Bend, 9 in. projection.

- 18x H Pipe, close.

- 20x T Pipe.

- 20xx Branch T Pipe.

Sizes : 3 x 2 in., 4 x 2 in., 4 x 3 in.

- 21x T Pipe Diminishing.

Sizes : 2 in., 3 in., 4 in.

- 22x Y Pipe.

- 24x Siphon, close.

- 28x " Elbow.

- 31x " Outlet.

- 48x New Throttle Valve with Movable Iron Seat.

- 49x Improved Screw Diaphragm Valve.

- 50x Improved Screw Sluice Valve tested to 60 lb. per sq. in.

- 105x Expansion Box and Lid with flanges, rubbers, and bolts complete, 24 in. high x 8 in. wide x 6 in. deep, capacity, 4¼ gallons.

India Rubber Rings for Expansion Joints.

Bolts and Nuts for Expansion Joints.

THE RAYBURN BOILER

NEW (AUTOMATIC)

Domestic Hot Water and Radiators: When connected to a 30-gallon indirect cylinder the boiler can take care of up to 75 sq. ft. of radiation surface including unlagged piping.

When connected to cylinders larger than 30 gallons the amount of radiation surface is reduced proportionately, e.g., 40 gallons—up to 50 sq. ft.; 50 gallons—up to 75 sq. ft.

Domestic Hot Water only: The boiler is suitable for connection to cylinders of from 10 to 50 gallons capacity.

Radiators only: When used to heat radiators only, the boiler will take care of up to 175 sq. ft. of radiation surface including unlagged piping.

There is a lower burffed boiler for use in soft water areas.



Size: 18½ in. wide, 14 in. high and 24 in. back to front.

Cylinder Size	Fuel Capacity	Water Capacity	Tappings	Diameter of Feed Pipe
10-50 gallons	1 cu. ft.	3½ gallons	1½ to	4 in.

RAYBURN COOKER



Making One Appliance, One Fire, One Fuel do the Two Jobs of Cooking and Water Heating.

There are various models of the Rayburn. Each with differences in detail to meet the different needs of different households. You can have a Rayburn with or without a boiler, with one oven or two. All Rayburns have the same basic design which has proved such a tremendous success.

AUTO-ACE JUNIOR



a new Wellstood water heater with modern
thermostatic control

1. Domestic hot water rating. British Standard short period rating with refuelling not more than once in 2 hours is 26,000 B.Th.U's. per hour.
2. The water heater is suitable for a 35-40 gal. cylinder and one towel rail.

The Heater's capacity is as follows :

- 3 hot baths an hour, or
- 1 hot bath and 2 radiators.

Remember that this is the output *per hour* when the control is advanced.
When wanted, smaller output is supplied economically.

**WELLSTOOD INSULATED COOKER AND WATER
HEATER**

It offers a full range of cooking temperatures—
for boiling, frying, simmering, roasting,
baking and slow cooking—plus a constant
supply of hot water.

Ovens are on right hand only. Boiler tapplings
can be supplied on either hand.



BAXENDALE & CO. LTD.

IDEAL DOMESTIC BOILER

No. 0-DE

For Hot Water Supply



Water Contents	Height to top plate A	Height to centre of flow B	Height to centre of return C
galls. 2.7	in. 21½	in. 18	in. 14
Number and Size of *Tappings in cleanout cover at back		Clean out opening at back	
Flow	Return		
in. 1—½	in. 1—½	in. 1—8 (6)	

In Grey Mottle or Cream Enamel

* Boilers with Bower-buffed firepots supplied with 1-in. Flow and Return tappings unless otherwise ordered. Side tappings can be provided at extra charge (1½-in. R.H. or L.H.; Bower-buffed 1-in. R.H. or L.H.)

Ratings—Fuel Capacity 2.6 cu. ft. Hot Water Supply only: B.T.U. per hour, 20,000. Gallons per hour: 40°—120°, 25; 40°—140°, 20. Approx. Tank Size 25—30 galls.

IDEAL No. 1 "AUTOCRAT" DOMESTIC BOILER

Thermostatic Control supplied as standard with boiler. Operated by a small Control Knob positioned right-hand side of front panel.



Height, floor to top plate A	Height to centre of flow tapping B	Height to centre of return tapping C
in. 25½	in. 21½	in. 14½
*Tapping in cleanout cover at back		Clean-out opening at back
Flow	Return	
in. 1	in. 1	in. 1—8 (6)

* Boilers with Bower-buffed firepots supplied with 1 in. Flow and Return tappings unless otherwise ordered.

Hot Water Supply only: B.T.U. per hour, 25,000.

Gallons per hour 40°—120°, 31; 40°—140°, 25

Water Contents 2.7 galls. Fuel Capacity 2.6 cu. ft. Approx. tank size 30—40 galls.

Boiler is dispatched assembled ready for installation.

Finished in Black and Cream Vitreous Enamel, with jacket Cream Sauce Enamelled. The Set of Striking Tools consists of Shovel, Straight Slice Bar and a combined Racking Lever and Lifter.

MILLER STREET · MANCHESTER

HEATING STOVES



➤ **"VESPER II" STOVE**

Vitreous Enamelled Finish

Heating Capacity (approx.) 3,000 cu. ft.

Can be fitted with a back boiler for ordinary domestic requirements

"COURTIER" STOVE

R Design

No. 2R, 4R, 6R, 8R, 10R.

Average Heating Capacity (cu. ft.) 1,400, 2,400,
3,500 5,000, 6,500

No. 6R, 8R, 10R can be supplied with boilers



➤ **"ESSE" STOVE**

No. 450

Vitreous Enamelled Finish

Can also be supplied with boiler for domestic use

Average Heating Capacity 3,000 cu. ft.



SHEET GLASS

Sheet Glass can be supplied in stock sizes for cutting purposes, or in squares cut to customers' sizes ready for glazing.

Standard weights are: 18 oz., 24 oz., 26 oz. and 32 oz. to the square foot; but for special purposes, sheet glass may be obtained either thinner or thicker than the above. For instrument glasses, etc.: two thicknesses are available, i.e., 1.2-1.5 mm. and 1.5-1.8 mm., corresponding to 9-12 oz. and 12-15 oz. respectively. In the thicker substances, $\frac{3}{16}$ in. and $\frac{1}{4}$ in. are available.

In 26 oz. and 32 oz. weights, sizes up to 84 in. long or 48 in. wide are usually available from stock.

STOCK: In cases and crates containing 300 ft. of 18 oz., 200 ft. of 24 oz., 26 oz. and 32 oz., usually 62 in. \times 42 in.

CUT SIZES: We appreciate the importance of exact cutting, and take special precautions to ensure accuracy. This, combined with our exceptional motor delivery arrangements, provides an attractive service for our customers.

HORTICULTURAL GLASS

We hold large stocks of all the standard sizes in boxes containing 200 square feet. Other sizes and quantities can be arranged for at short notice,

COLOURED SHEET GLASS

Usual colours always in stock—Ruby, Blue, Green, Signal Green, in 15 oz. or 21 oz.

OPAL

Flashed opal on clear sheet and pot opal are available, 15 oz., 21 oz., 26 oz. and 32 oz. Can also be supplied in flashed opal on certain colours, or certain colours flashed on Pot Opal.

FLUTED SHEET

Available in 21 oz. in sheets or squares.



These walls glazed with Vitrolite in standard Ashlar Panels and fixed with Mastic can be seen in our Miller Street Warehouses.

VITROLITE GLASS

VITROLITE is an opaque glass having a natural fire-polished surface which is hard, non-absorbent and easily cleaned. It can be fixed with a minimum of labour to almost any surface which is strong enough to carry its weight. Made in a variety of brilliant colours, its use is desirable wherever a clean, hygienic, and permanent surface is required.

COLOURS. The following page gives a range of the most popular tints.

NOTE.—The exact shade cannot be guaranteed, and may be either lighter or darker as one melting always varies a little from another.

THICKNESS. All the colours shown are obtainable in $\frac{5}{16}$ -in. substance. Black and White only are also available in $\frac{7}{16}$ -in.

SIZES. Stock size sheets are manufactured in sizes 120 in./144 in. long and 50 in./60 in. wide. These can readily be cut to any desired size. For Wall-lining work, special Standard Ashlar sizes have been arranged.

(Continued on page 313)

LANCASTER · LEEDS · BLACKPOOL

VITROLITE GLASS

FOR WALL-LININGS, SHOP-FRONTS,
TABLE-TOPS, SHELVES, SPLASHBACKS, ETC.



PRIMROSE

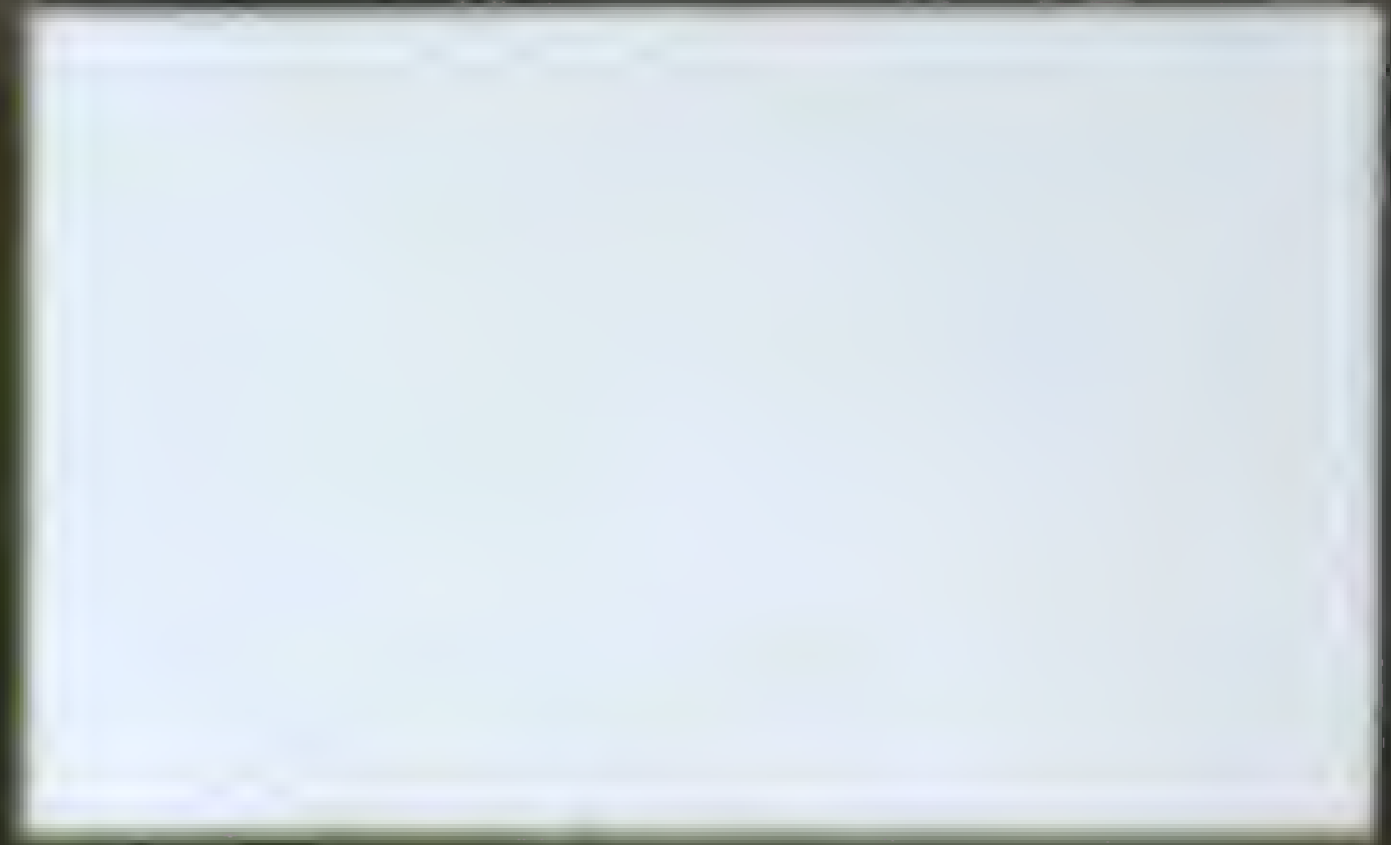

TURQUOISE



GREEN



IVORY



PEARL GREY



EGGSHELL



GREEN ADAM



CREAM

CAN ALSO BE SUPPLIED
IN BLACK OR WHITE

VITROLITE GLASS

SIZES (continued from page 311.)

These are prepared with accurate flat ground edges, forming a handy and economical method of using the glass. Sizes are 15 in. × 10 in., 15 in. × 15 in., 18 in. × 12 in., and 21 in. × 14 in.

FIXING. Vitrolite is easy, clean, and more rapid to fix than tiles. Surfaces to which the glass is to be fixed must be rendered non-absorbent by the use of a special Sealing Agent, and fixing is done with a special type of Mastic. Vitrolite can be cut to shape, drilled, bent, and worked in much the same way as ordinary glass; edges can be finished, and the surface can be matted or sandblasted for decorative effects. Full fixing information will be given on request.

A FEW USES. For Wall-Linings in bathrooms, lavatories, kitchens, larders, corridors, operating theatres, hairdressing saloons, cafes, restaurants, butchers' and fishmongers' shops, dairies, and for the exterior of buildings generally. For shelves, display fittings, shop window fixtures, table and counter tops, protective coverings for mantelboards, window bottoms, and finger plates. For decorative work on exterior of shops, cinemas and hotels, as fascias, name plates, pilasters and risers.

We shall be pleased to quote prices on receipt of a specification.

TRIPLEX (Regd.) SAFETY GLASS

TripleX Laminated Safety Glass. We have installed plant at our Works, and are able to offer customers TripleX Safety Glass from stock. In normal times replacements can be supplied at very short notice, and for ordinary sizes frequently while messenger waits. It can be cut, worked, and drilled like ordinary glass.

As a laminated Safety Glass, TripleX is the outstanding make, and we offer this in preference to cheaper productions with the utmost confidence.

The Manufacturers' guarantees are fully operative for all glass from our stocks.

TripleX Toughened Safety Glass is a plate glass treated to increase its strength and resistance to heat and fracture. This has to be manufactured specially to the required sizes, and can only be obtained some few days after receipt of order.

No drilling, cutting or after-process can be carried out after the glass is once made.

Both the above Glasses conform with the Road Transport Act definition of Safety Glass.

REEDED GLASSES

Figured Rolled Patterns average $\frac{1}{8}$ -in. thick, but some patterns obtainable $\frac{1}{16}$ -in. and $\frac{1}{4}$ -in. thick can be made by arrangement.



No. GL 313. MAJOR REEDED



No. GL 311. CROSS REEDED



No. GL 312. LUMINATING

Made in White only. *Illustrations show actual size of pattern.*

When ordering reeded glasses please state height and width, and say whether the reeds are to be horizontal or vertical. If the reeds in adjacent squares are to line up, this should also be stated.

REEDED GLASSES

Figured Rolled Patterns average $\frac{1}{8}$ in. thick.

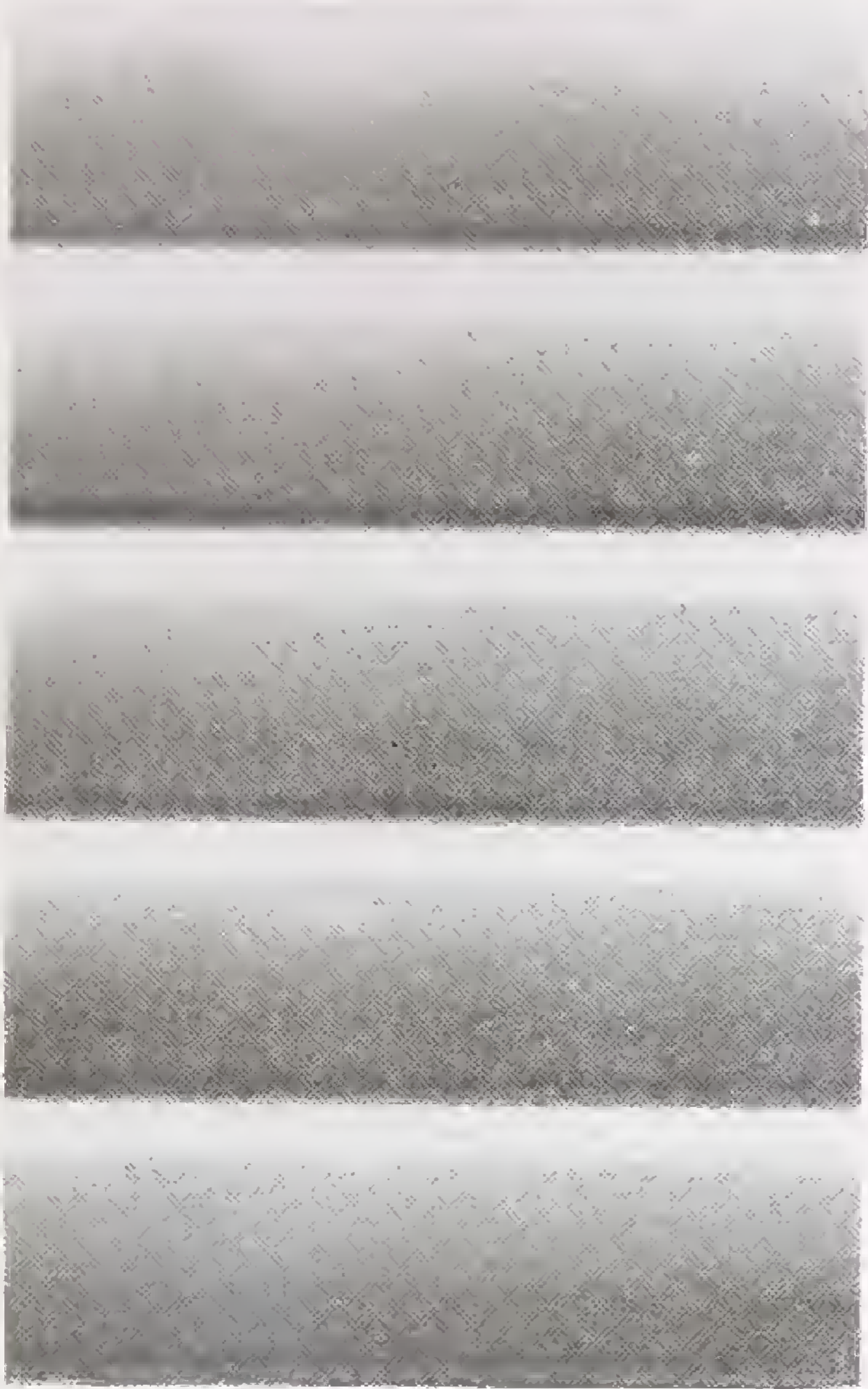

No. GL 307. NARROW REEDED



No. GL 308. BROAD REEDED

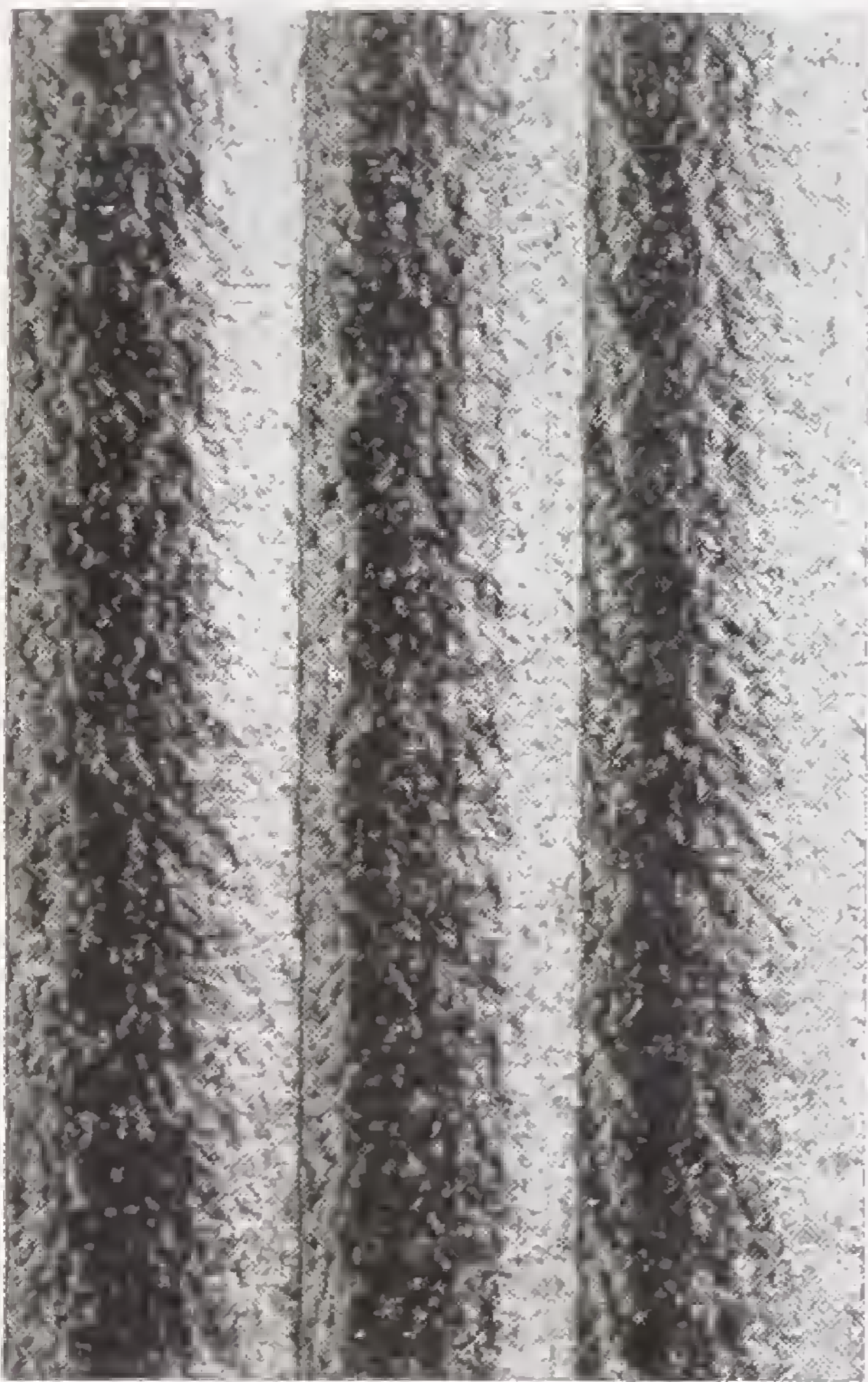

No. GL 309. NARROW REEDLYTE

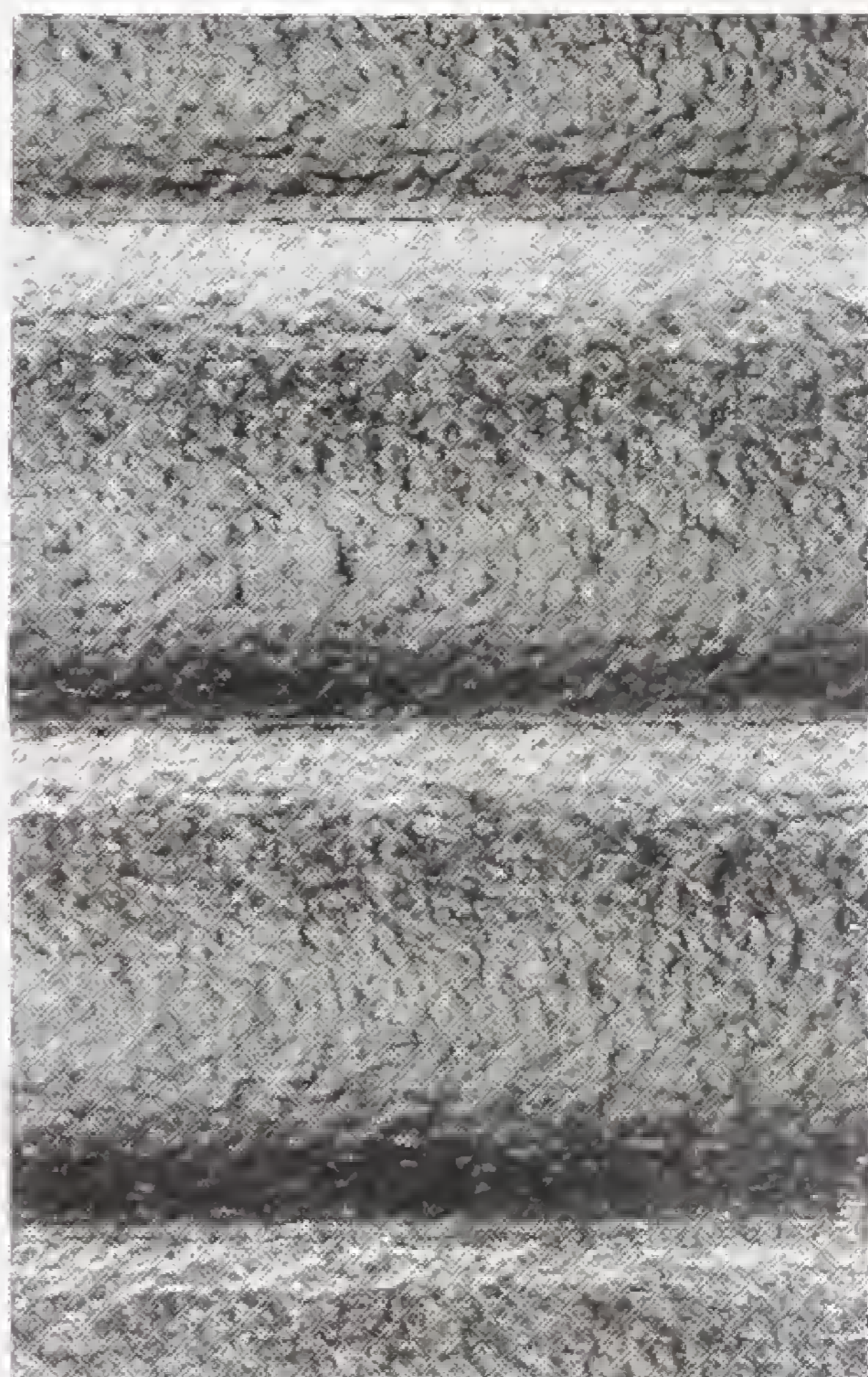

No. GL 310. BROAD REEDLYTE

Made in White. *Illustrations show actual size of pattern.*

When ordering reeded glasses please state height and width, and say whether the reeds are to be horizontal or vertical. If the reeds in adjacent squares are to line up, this should also be stated.

CATHEDRAL GLASS

The following illustrations give some idea of the more popular Cathedrals. There are, however, a number of other types not so heavily marked, and which do not allow of illustration, but which are carried in stock.



No. GL 85. WATERWITE



GL 315 ROUGH CATHEDRAL



GL 104 No. 2. HAMMERED



GL 316 RIMPLED

Illustrations show actual size of pattern.

Cathedrals average rather less than $\frac{1}{8}$ -in. thick.
Made in White, Green, Pink, Blue and Yellow.

FIGURED ROLLED GLASS

Figured Rolled Patterns average $\frac{1}{8}$ in. thick, but for special purposes $\frac{3}{16}$ in. and $\frac{1}{4}$ in. thick can be made by arrangement

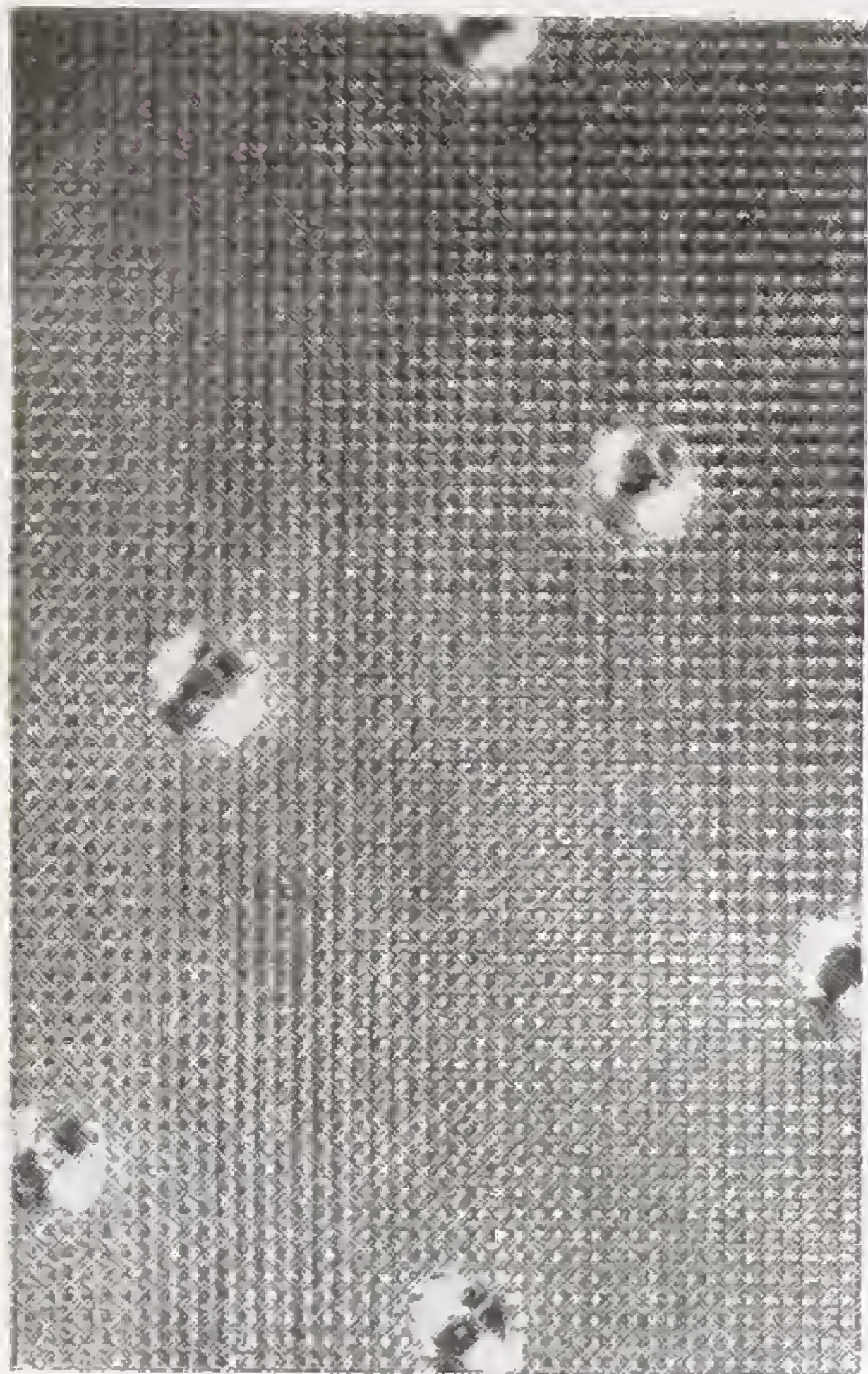

No. GL 303. SPOTLYTE

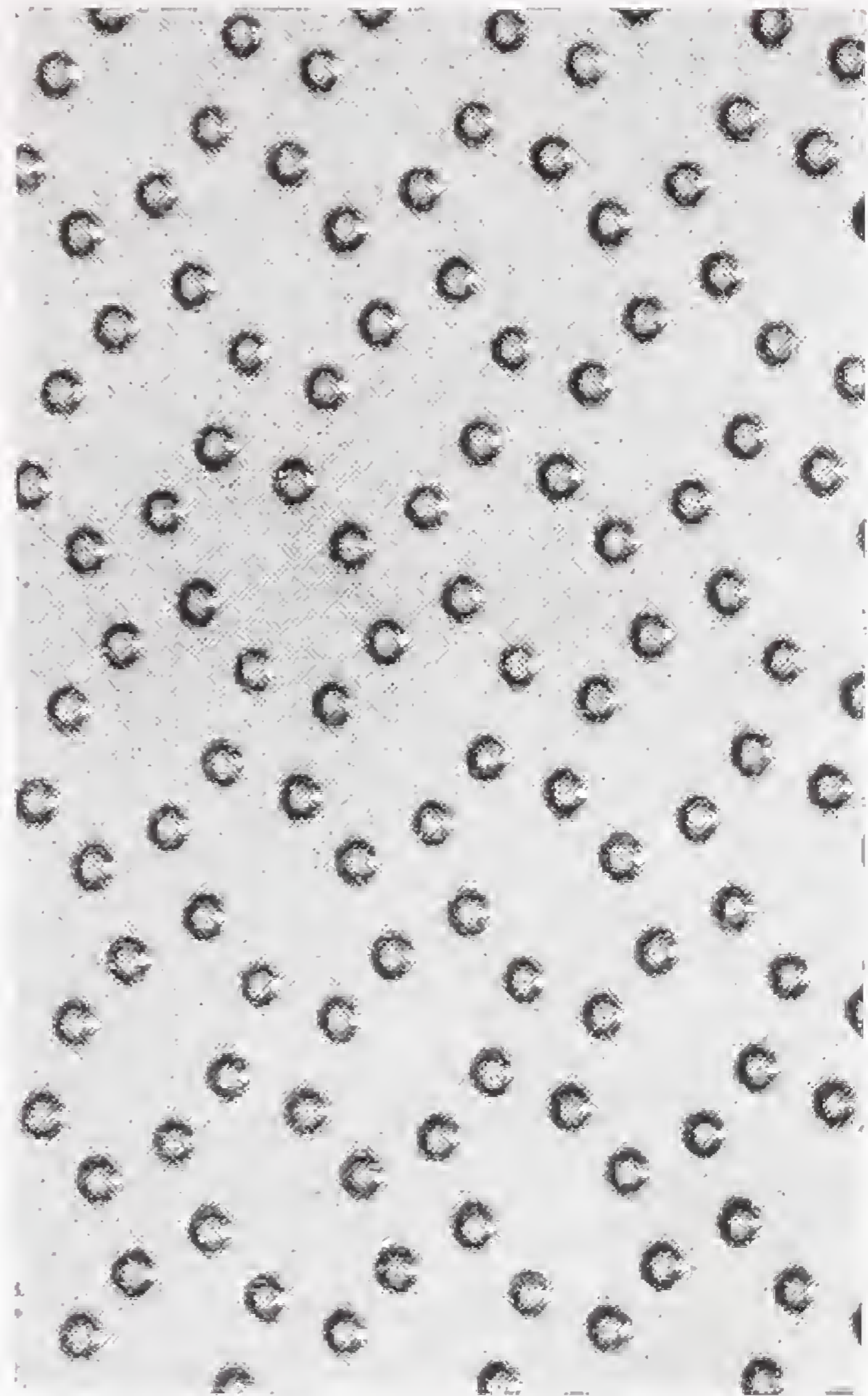

No. GL 304. FESTIVAL

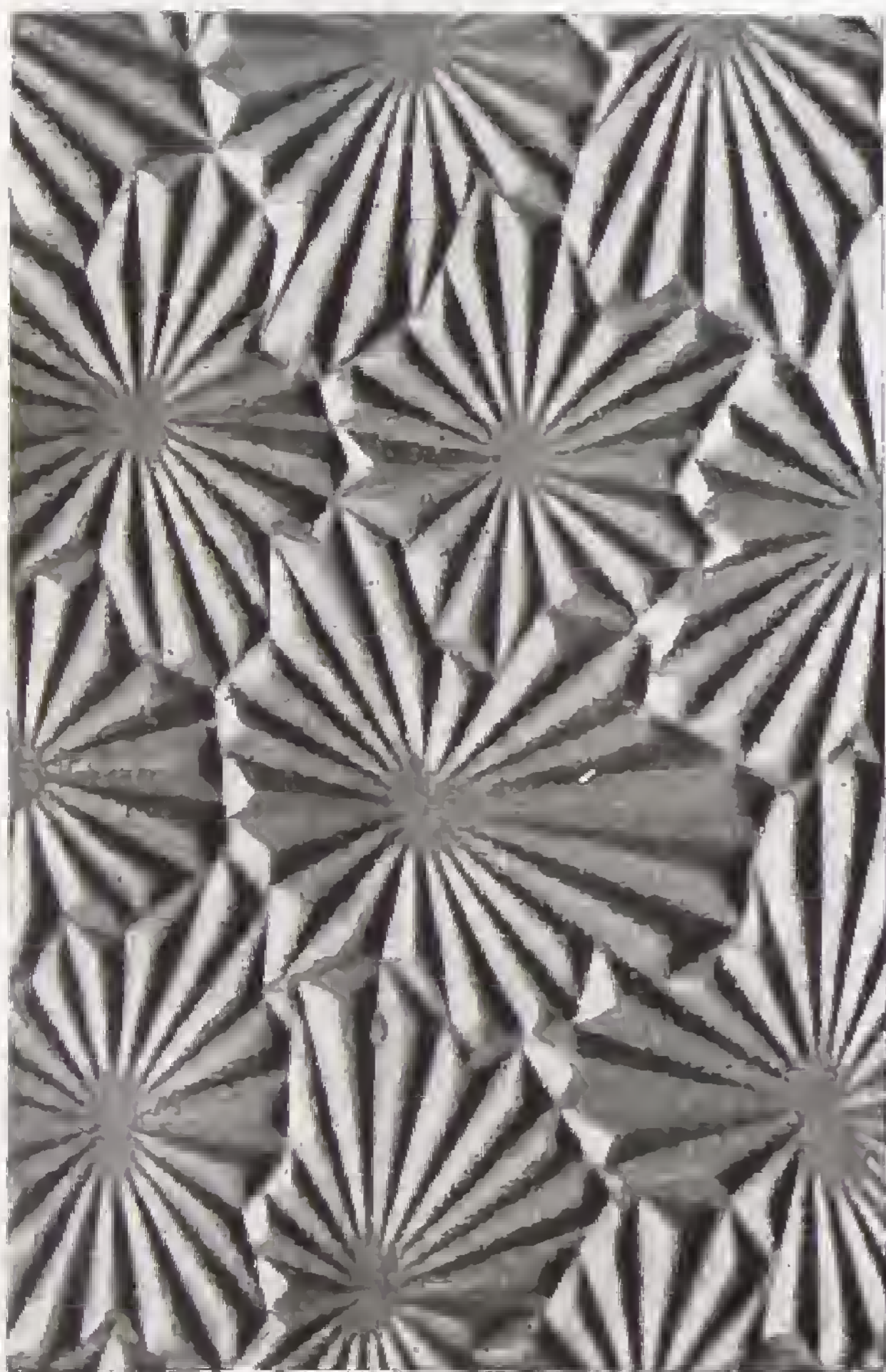

No. GL 115. MURANESE



No. GL 317. SMALL FLEMISH

Made in White. *Illustrations show actual size of pattern.*

Many patterns can be obtained in Green, Pink, Blue, and Yellow.

FIGURED ROLLED GLASS

Figured Rolled Patterns average $\frac{1}{8}$ in. thick, but for special purposes $\frac{3}{16}$ in. and $\frac{1}{4}$ in. thick can be made by arrangement.



No. GL 103. LARGE FLEMISH
Can also be supplied in small pattern.



No. GL 305. MERSEY

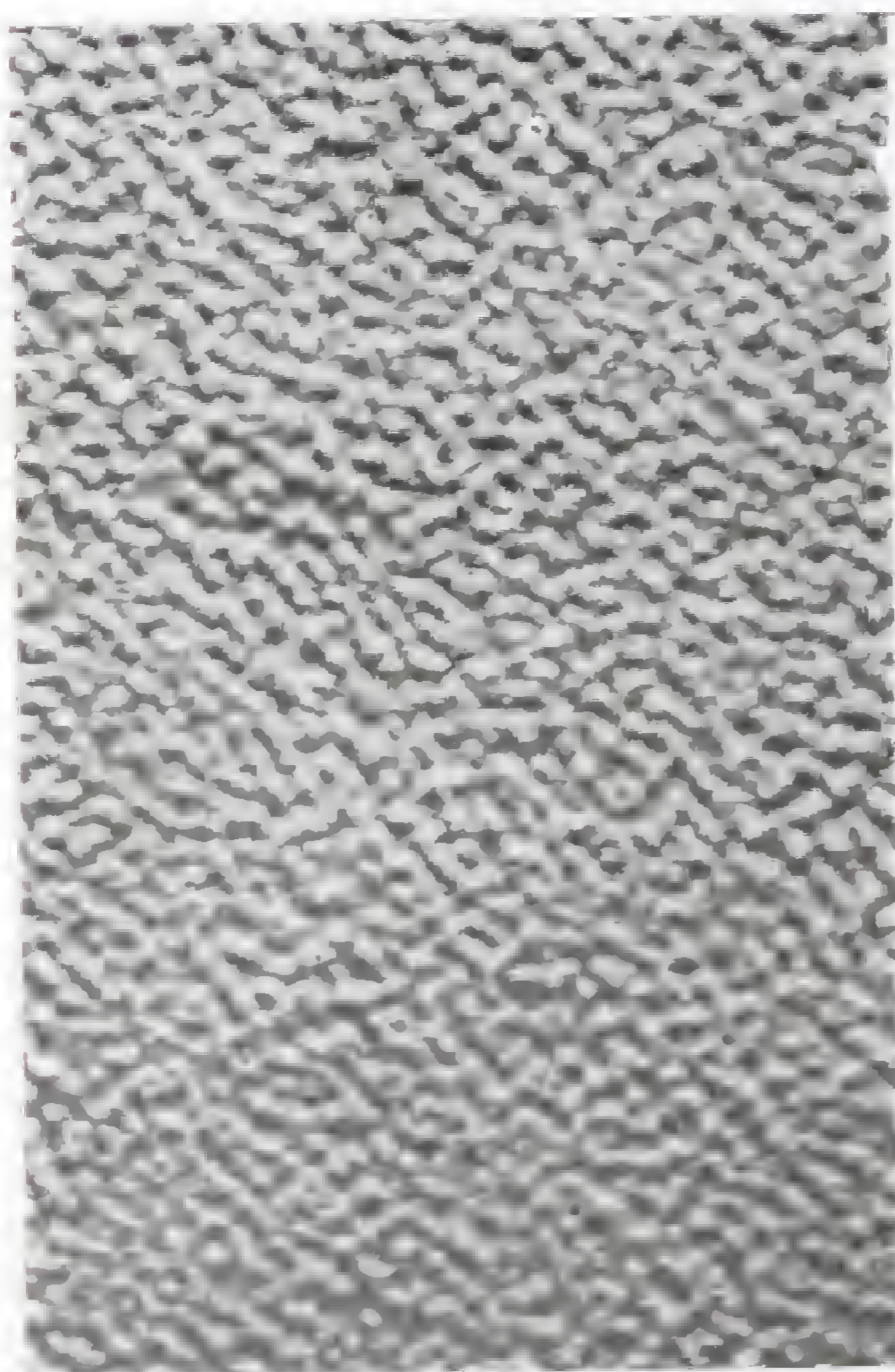

No. GL 105. STIPPOLYTE



No. GL 306. ARGENT

Made in White. For Argent see Note on page 314 about height and width
Many patterns can be obtained in Green, Pink, Blue, and Yellow.

FIGURED ROLLED GLASS

Figured Rolled Patterns average $\frac{1}{8}$ -in. thick, but for special purposes $\frac{3}{16}$ -in. and $\frac{1}{4}$ -in. thick can be made by arrangement.



No. GL 301. PINSTRIPE

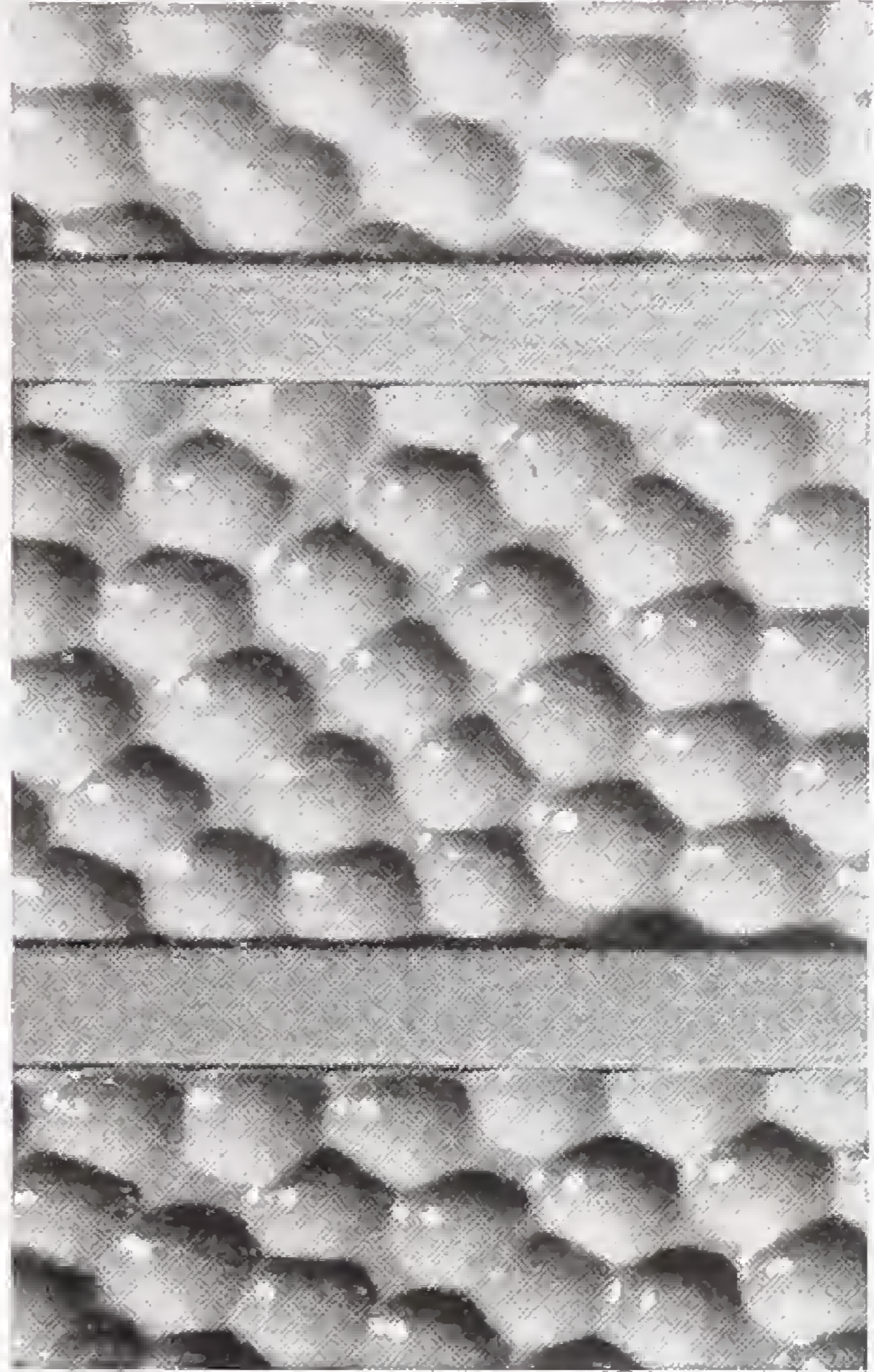

No. GL 302. HAMMERSTRIPE



No. GL 123. LARGE ARCTIC



No. GL 89. SMALL ARCTIC

Illustrations show actual size of pattern.

Made in White. For Pinstripe and Hammerstripe see Note on page 315 about height and width.

FIGURED ROLLED GLASS

Figured Rolled Patterns average $\frac{1}{8}$ -in. thick, but for special purposes $\frac{3}{16}$ -in. and $\frac{1}{4}$ -in. thick can be made by arrangement.

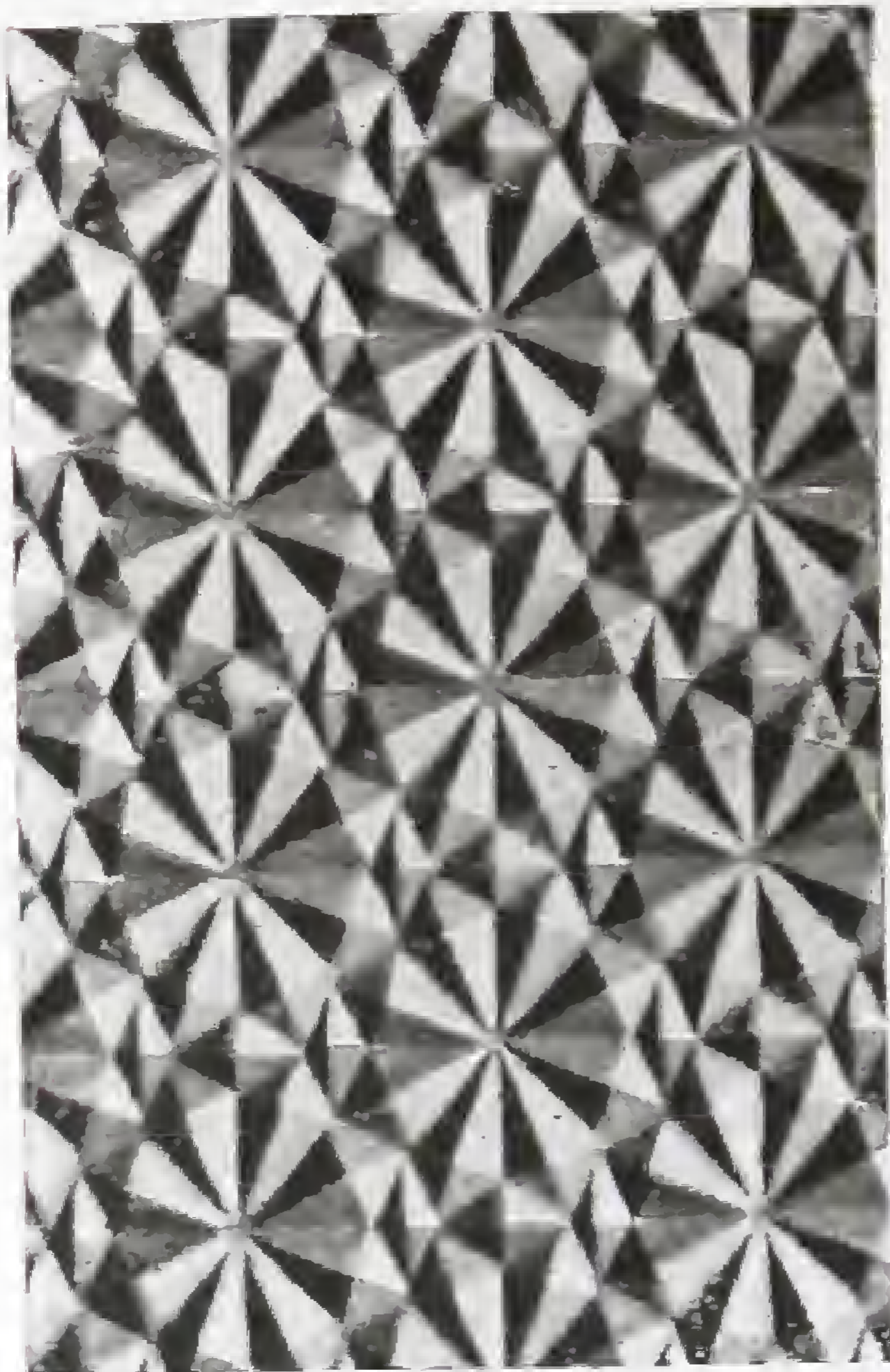

No. GL 128. KALEIDOSCOPE

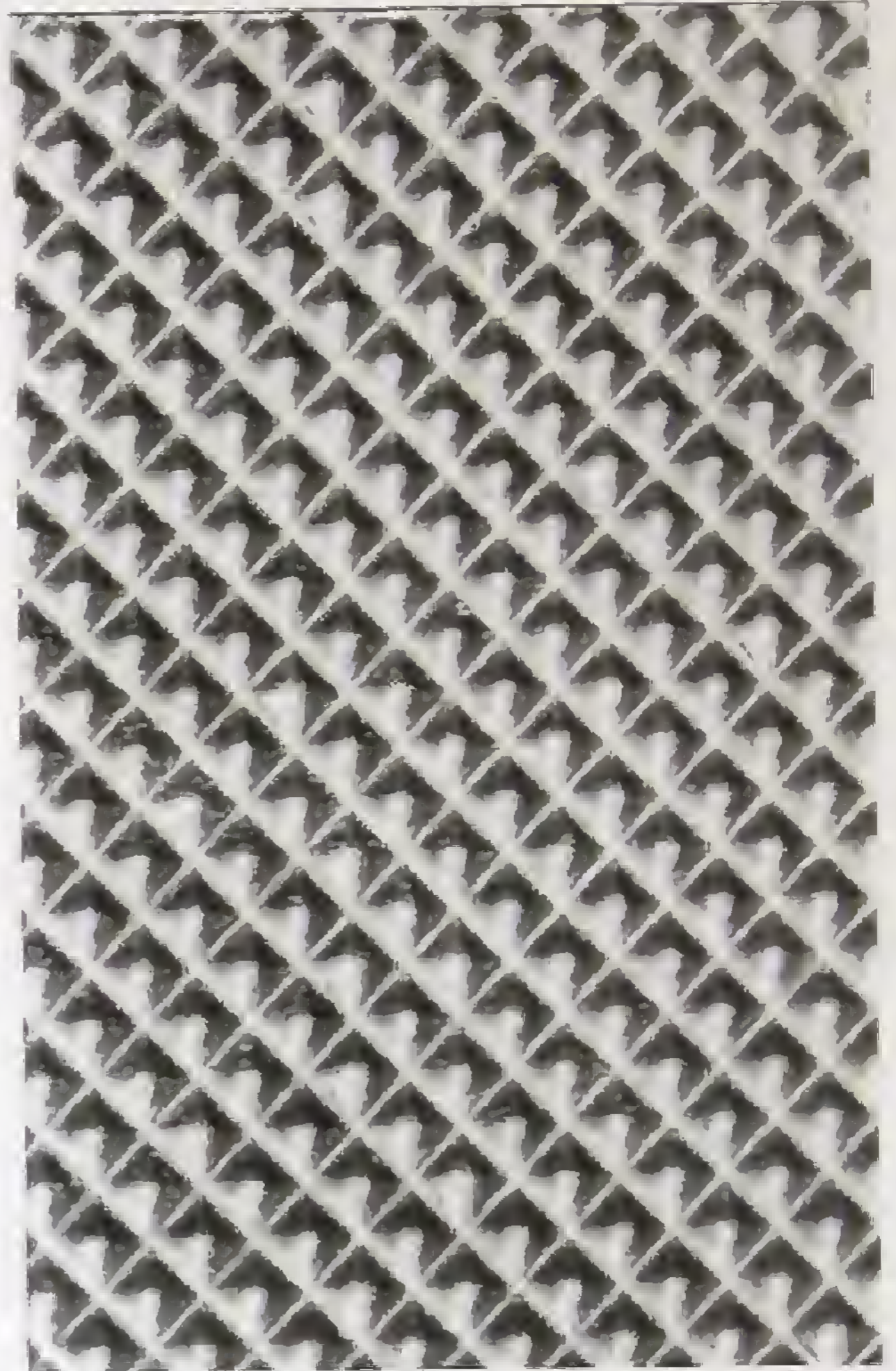

No. GL 300. BOREALIS



No. GL 319. SPARKEL

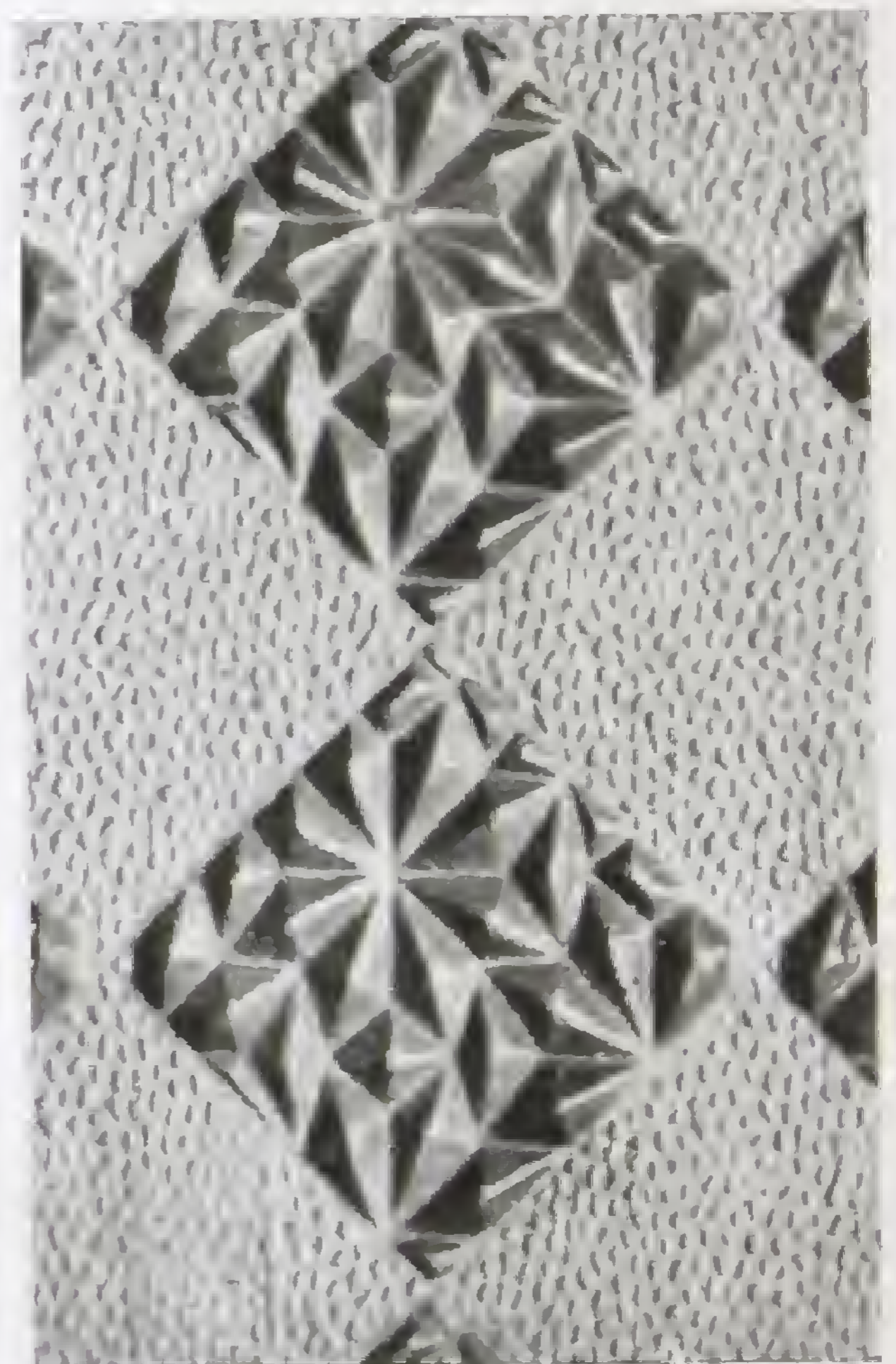

No. GL 93. AMAZON

Made in White. *Illustrations show actual size of pattern.*
Many patterns can be obtained in Green, Pink, Blue and Yellow.

FIGURED ROLLED GLASS

Figured Rolled Patterns average $\frac{1}{8}$ -in. thick, but for special purposes $\frac{3}{16}$ -in. and $\frac{1}{4}$ -in. thick can be made by arrangement.



No. GL 124 JAPANESE



No. GL 90. PINHEAD MOROCCO

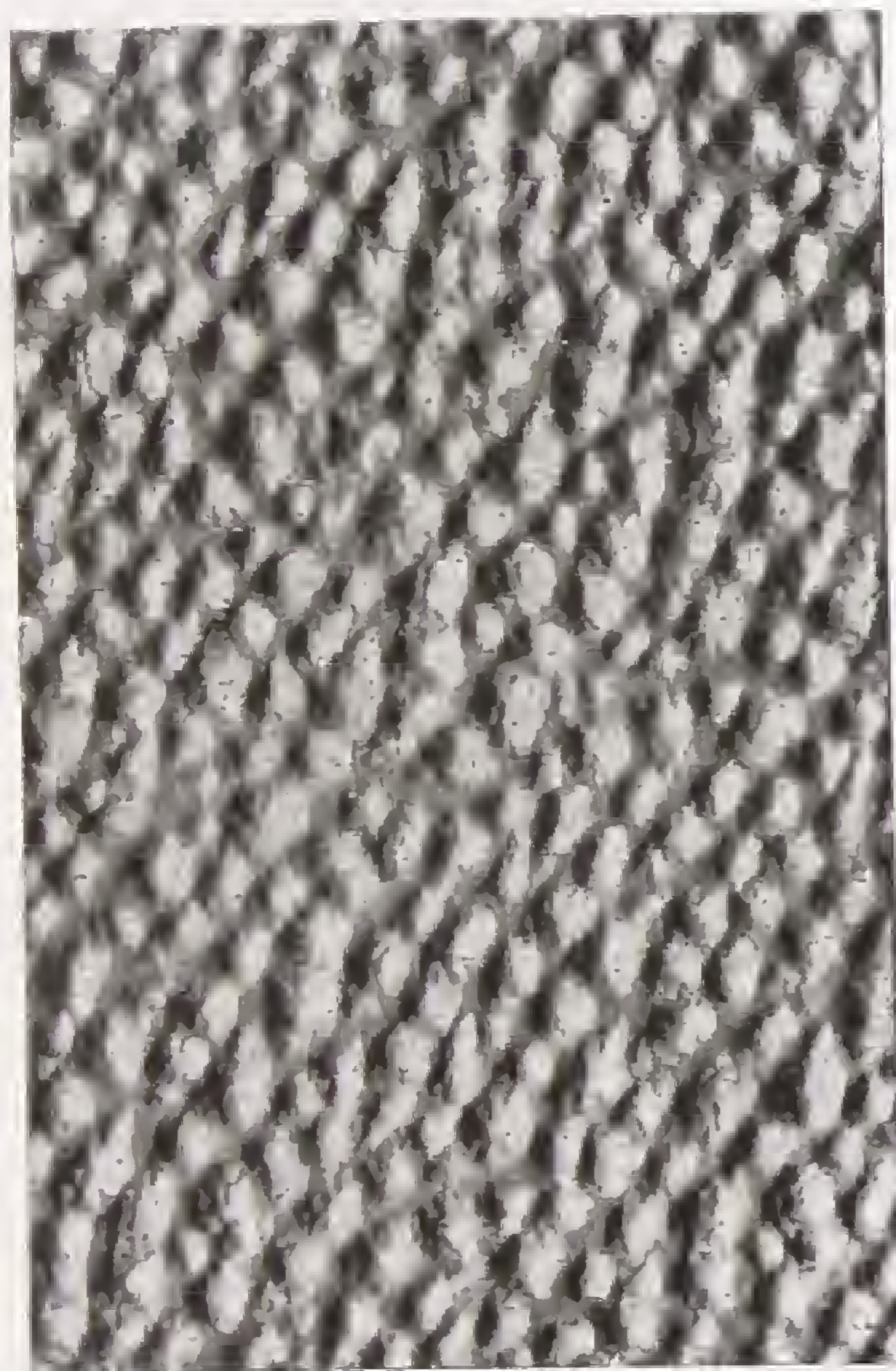

No. GL 125. SMALL MOROCCO

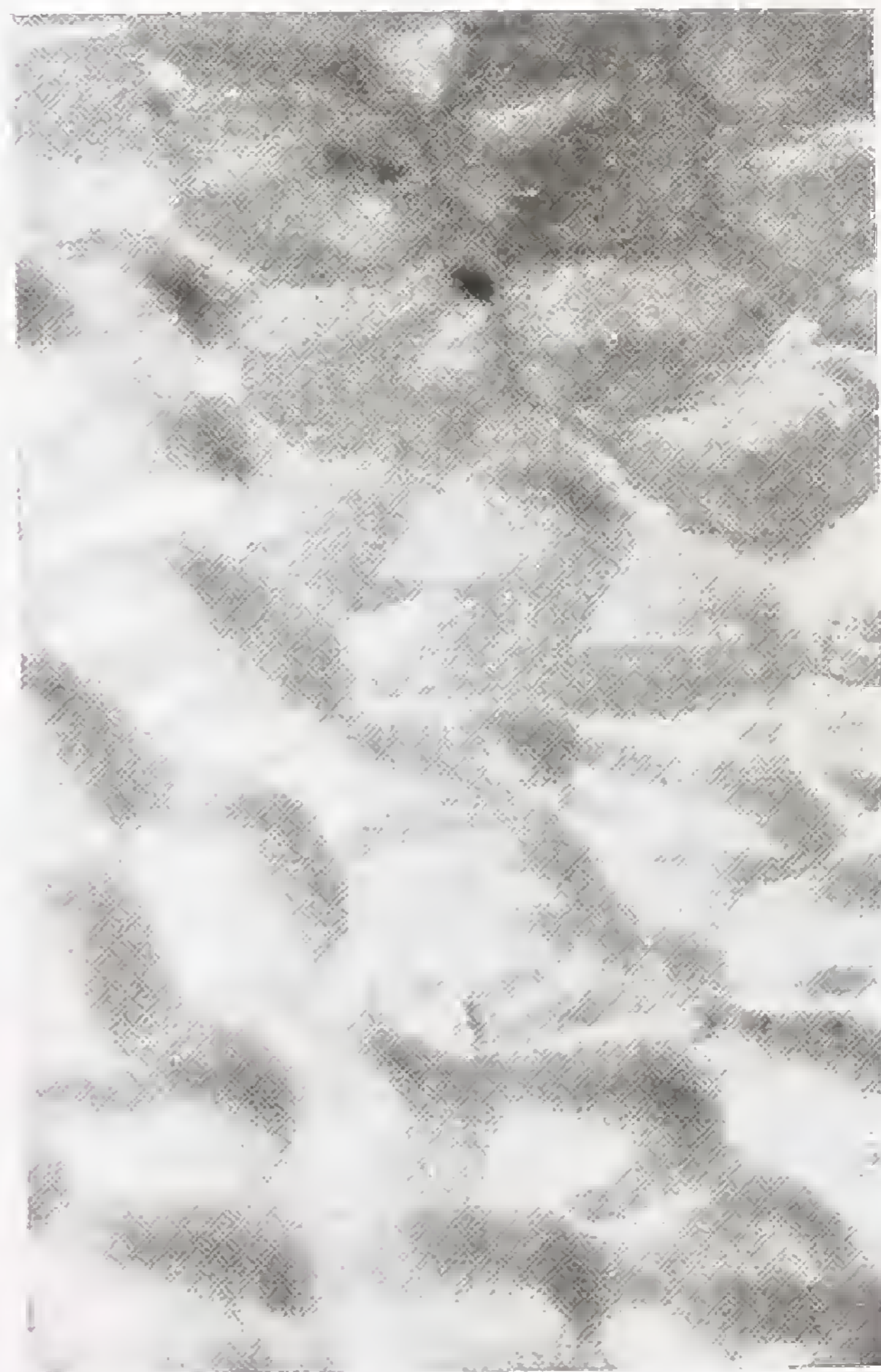

No. GL 318. GLASGOW HAMMERED

Made in White. *Illustrations show actual size of pattern.*
 Many patterns can be obtained in Green, Pink, Blue and Yellow.

ROLLED, ROUGH CAST, AND WIRED GLASS

PLAIN ROLLED, also known as **HARTLEY'S ROLLED** is manufactured in $\frac{1}{8}$ in.

ROUGH CAST DOUBLE ROLLED, also known as **CAST** or as **ROUGH PLATE**, is made in $\frac{3}{16}$ in., $\frac{1}{2}$ in., and $\frac{3}{8}$ in. substances.

Ordinary limits of size are 144 in. in length and 44 in. in width, but sizes can be manufactured up to 156 in. long, 146 x 48 in. at extra rates.



**GL 75
WIRED CAST**

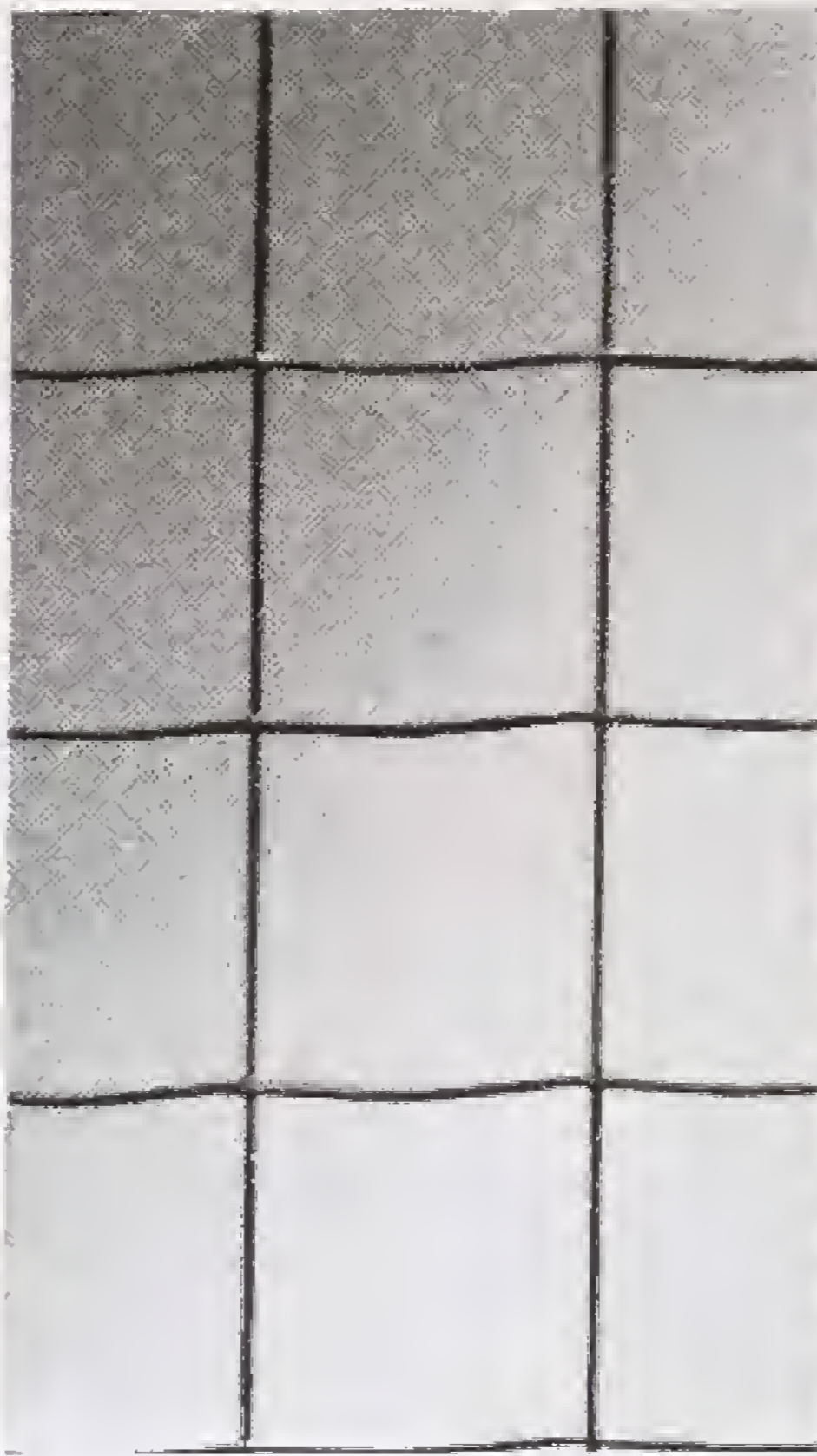

**GL 78
GEORGIAN WIRED
POLISHED**

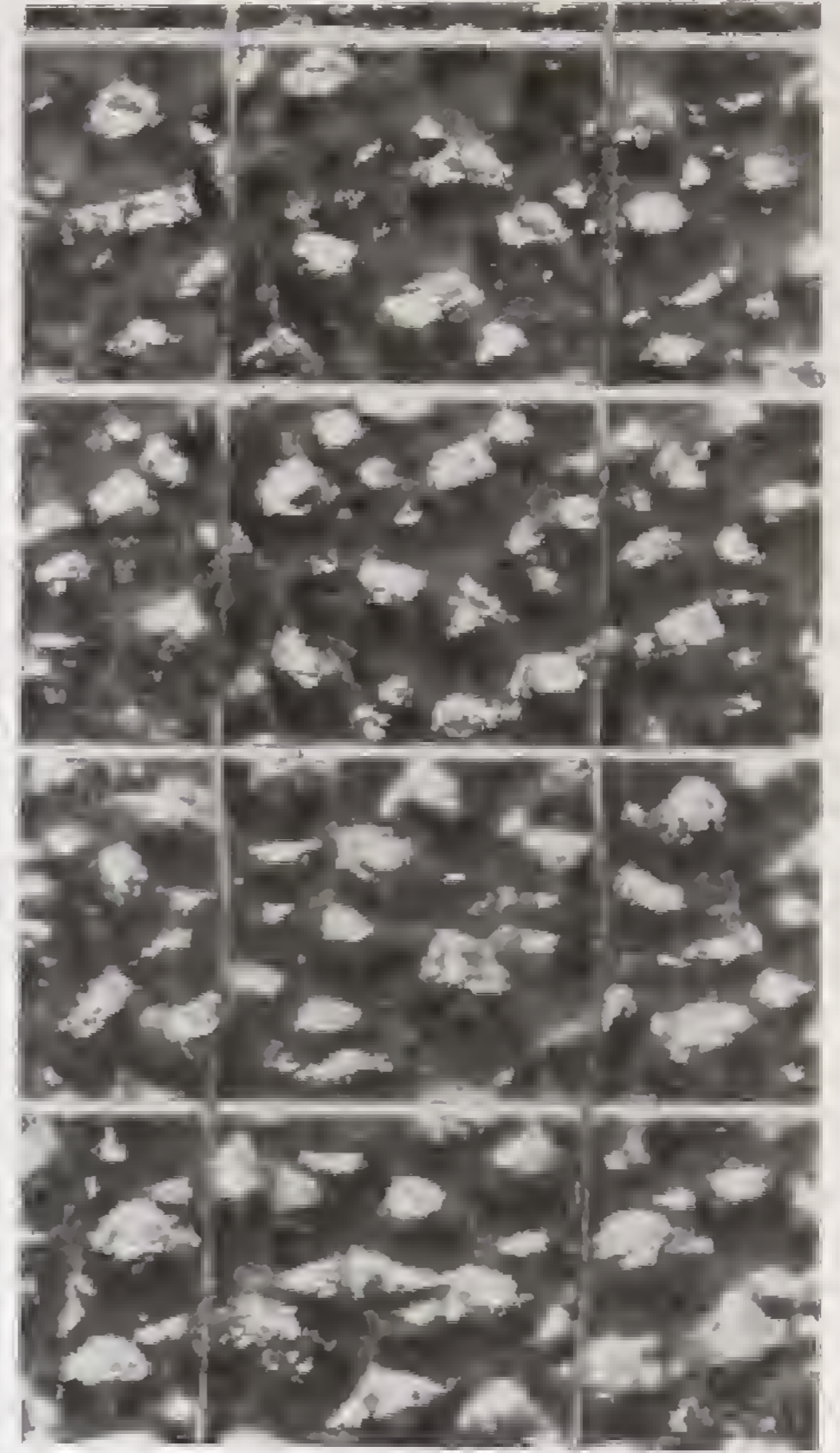

**GL 77
GEORGIAN WIRED
ROUGH CAST**

WIRED GLASS, as its name implies, consists of a sheet of glass having wire netting embedded in its centre. The wire being hermetically sealed up in the glass is protected from rust or corrosion and is practically everlasting.

WIRED CAST, and **GEORGIAN WIRED ROUGH CAST** are only manufactured in $\frac{1}{2}$ in. substance.

The ordinary hexagon mesh will always be supplied unless Georgian is specified.

Available sizes :

Wired Cast, 132 in. long 40 in. wide, or at extra rates 148 in. long 50 in. wide.

Georgian Wired Cast, 132 in. long 40 in. wide extreme, or at extra rates 148 in. long.



GL 79 PRISMATIC GLASS

Placed flush with the outside wall it takes up all the light that strikes the window opening, thus illuminating with a well-diffused natural light the parts of the room farthest from the window.

Glazes like Ordinary Glass with Flutes inside.

$\frac{1}{2}$ in. thick. In White only.

For Dark Cellars and Basements it more than repays its original cost in the saving of artificial light alone.

Made in Three Varieties, thus :—

Near Light, Middle Light, and Far Light.

When ordering please state which measurement is height and which is width.

MUROGLASS Coloured opaque glass is now available for wall cladding.

GLASS VENTILATORS AND PAYHOLES

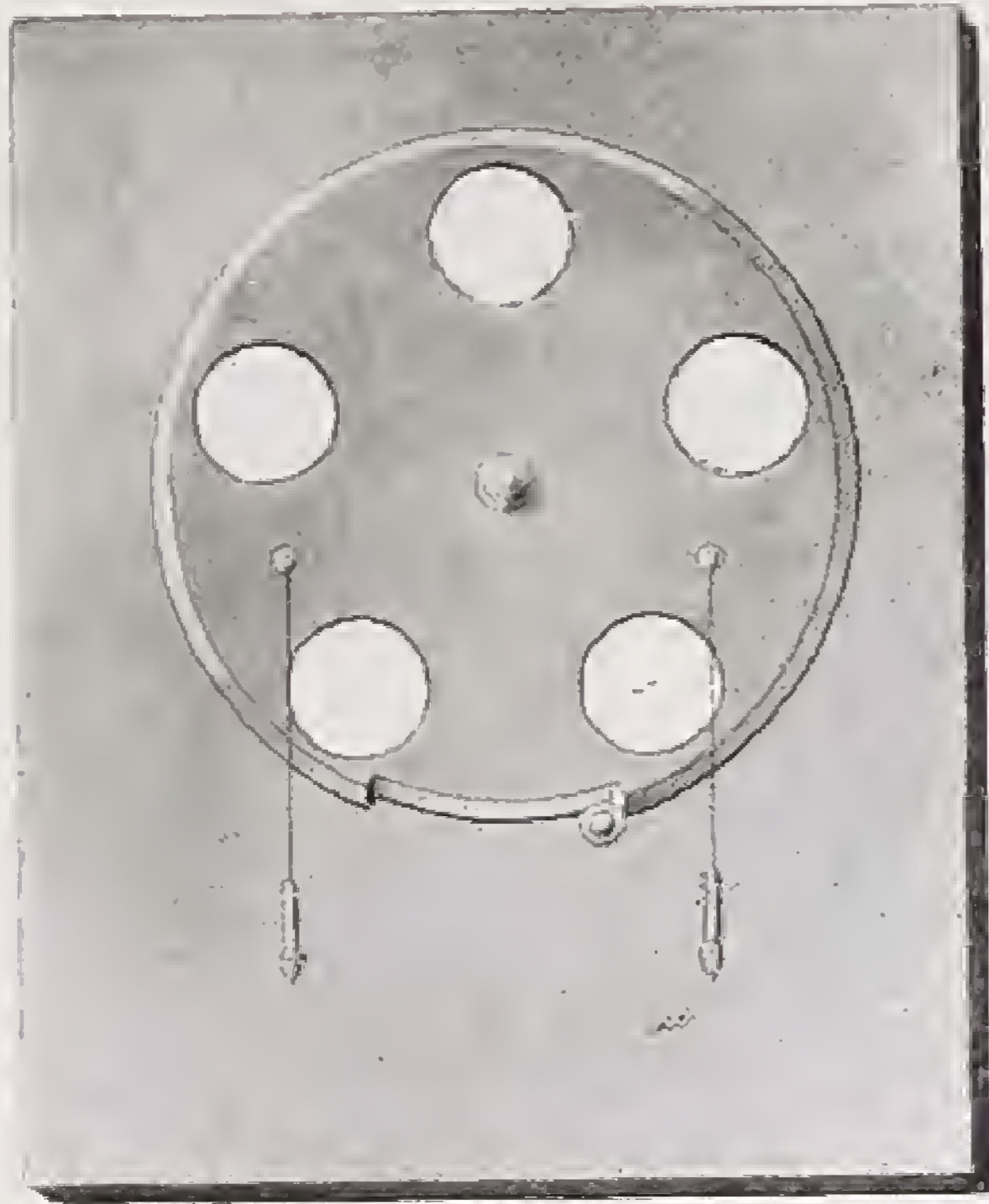

No. GL 172
**CIRCULAR GLASS
VENTILATOR**

Complete with cords

By a slight turn of the circular glass it is either open or shut.



No. GL 190
PAY HOLE

Edges Rounded and Polished.
Any Lettering to Order.

In ordering Circular Glass Ventilators please state description of glass required, HEIGHT and WIDTH in Rebates, and, if the circles are desired in any particular position.

Any size of glass may be fitted with these ventilators.

No. GL 170
**LOUVRE GLASS
VENTILATOR**

Brass Frame Green Bronze Lacq.
Finish.

Ventilators and Pay Holes may also be made in Obscured, Ornamental, or Embossed Glass, to Order.

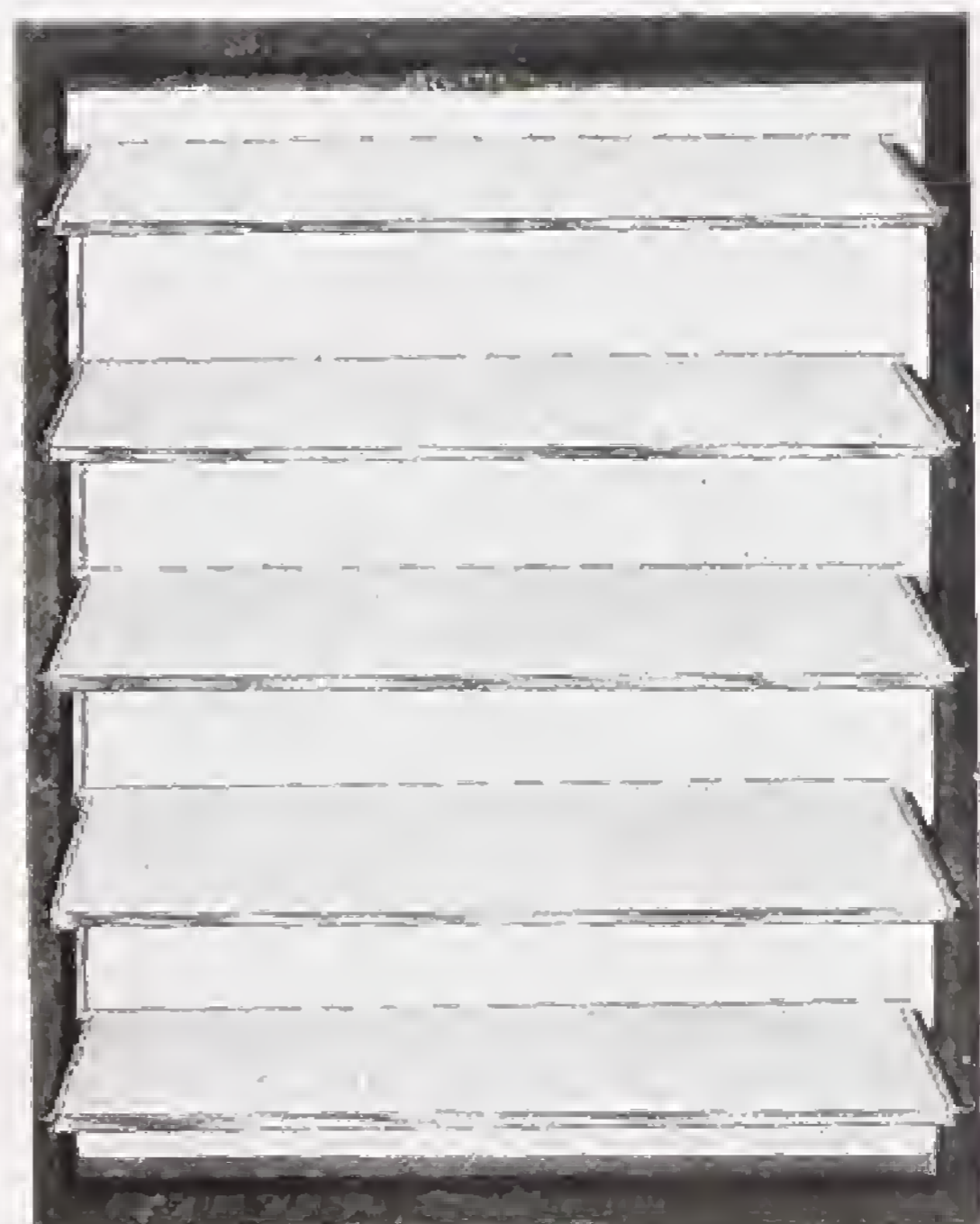

BEVELLED GLASS



No. GL 151
Bevel to
Feather Edge

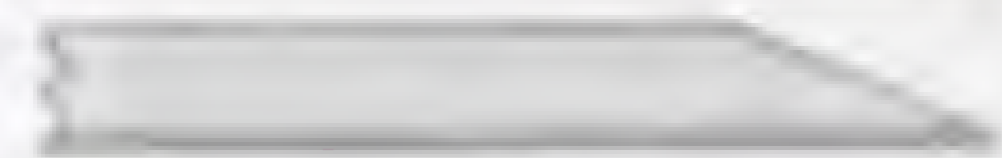

No. GL 156
Double Bevel

Section



No. GL 152
Ordinary Bevel

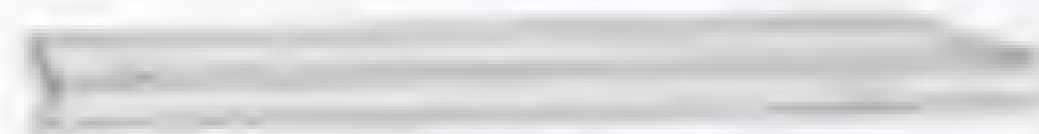

No. GL 171
Cross Bevel

Section



No. GL 153
Half-Nipped
Bevel

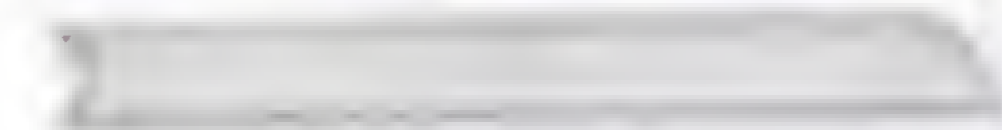

No. GL 158
Rounded and
Polished Edges

Section

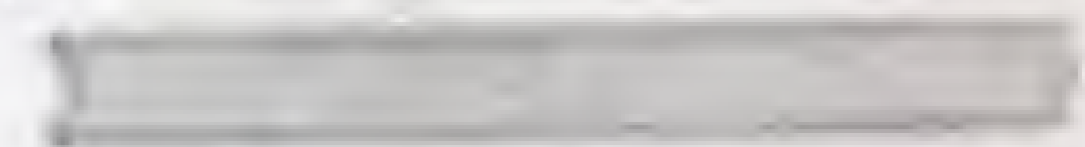

No. GL 154
Flat
Polished Edge

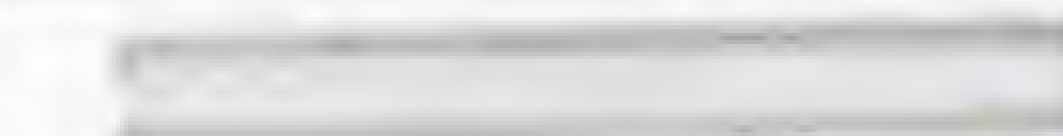

No. GL 159
Rounded Edge
and Hole
Drilled

Section

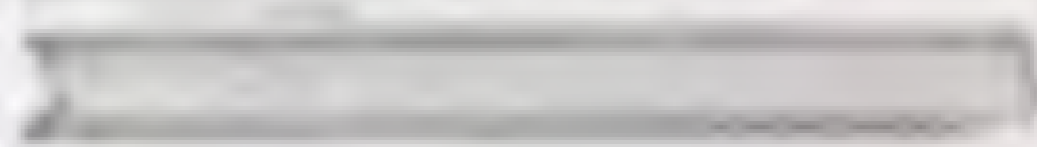

No. GL 155
Bevel and
Beaded



No. GL 162
Scalloped
Bevel

Section



For descriptions see following page

BEVELLED GLASS



(Illustrations on previous page)

ANY size of Plate may have Bevelled Edges, and the bevelling may be any desired width. It is usually $\frac{1}{4}$ in., $\frac{3}{8}$ in., $\frac{1}{2}$ in., $\frac{5}{8}$ in., $\frac{3}{4}$ in., $\frac{7}{8}$ in., 1 in., $1\frac{1}{4}$ in., $1\frac{1}{2}$ in., $1\frac{3}{4}$ in. or 2 in.

In Ordinary Bevelling the edge is mitred off until the edge is left about $\frac{1}{8}$ in. thick or more, according to the thickness of the glass before bevelling, and the edge is left slightly rough as it comes from the diamond in cutting.

When required, the bevelling may be carried out at a more acute angle, leaving a much narrower edge, and giving a greater raised effect to the glass, at a higher cost.

Where the edge of the glass is not fixed into rebates, but shows to the sight, it is necessary either to "bevel to feather edge"—in which but a very narrow edge is left—or else the edge is ground flat upon the wheel, and, if necessary, afterwards polished.

In "Arrising" the sharp edges only are ground off, as shown in Section GL. 159.

For Shelves, the edges are usually rounded and polished. They may also be arrised or polished flat.



HOLES may be drilled any size, and holes of special shape may be Sandblast Drilled.

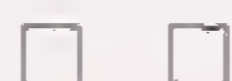

Cross Bevel or Scalloped Bevel or "Bevelled and Beaded" are very suitable for Mirrors and Ornamental Glasses.

BAXENDALE & CO. LTD.

T & W IDE'S
DIAGRAMS OF
CURVES FOR
BENDING
PLATE GLASS

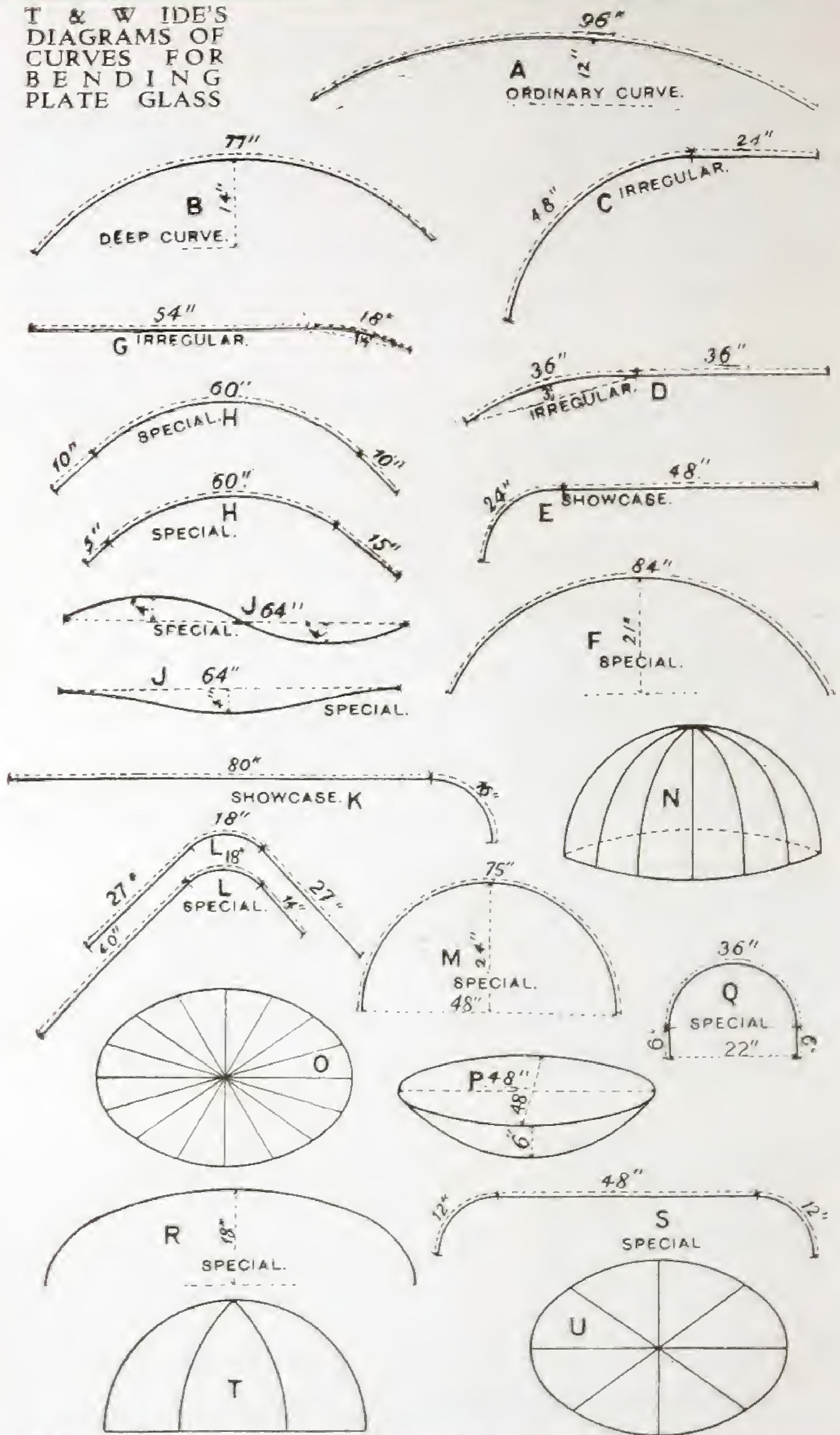

When asking for prices please send template or scale drawing. See next page.

MILLER STREET · MANCHESTER

**EXPLANATION OF GLASS BENDING CURVES
AND DIAGRAMS**

Illustrations on previous page.

- A.—Curves are those which are bent to a given radius one way of the pane only, which applies to the whole length or width of the pane, and not to one part only. The depth of bend not to exceed one-eighth of the length of the bent side of pane. Example, length of the bent side of pane, 26 in., depth of bend not above 2½ in.
- B.—Curves are those which are bent more than one-eighth but not to exceed the quarter of a circle, or about 1 in 15. Example, plate 72 in., bend 1½ in.
- C.—For the same curve as B, but a part flat, the flat part not to exceed one-third. Example, plate 74 in., bend 1½ in., flat 24 in.
- D.—For flat curves, with one part flat, the depth of the bent part not to exceed 1 in 12 and the flat part one-half. Example, plate 72 in., bend 20 in., depth 1 in., flat 18 in.
- E.—For curves, the bent part not less than a 6 in. radius, and not to exceed the quarter of a circle, with flat part, the flat part to exceed one-third, but not to exceed two-thirds. Example, plate 72 in., bend 24 in., flat 48 in.
- F.—Curves are those which are bent beyond the quarter of the circle but not to exceed 1 in 4. Example, plate 84 in., depth 2½ in.
- G.—Curves similar to D, the depth of bent part not to exceed 1 in 12, and the flat to exceed one-half, but not to exceed three-fourths. Example, plate 72 in., bend 18 in., depth 1½ in., flat 54 in.
- H.—For angular curves, etc.—Flat parts on each side, the centres not to exceed the quarter of a circle, and the flat parts one-fourth of the sides bent. Example, plate 80 in., bend 80 in., flat 10 in. each side, or about 1/10th one side and 1/20th the other.
- I.—For CG curves, depth not to exceed 1 in 16. Example, plate 84 in., depth 4 in.
- K.—Similar to H, with flat part to exceed two-thirds, but not to exceed 8/10ths. Example, plate 90 in., bend 26 in., flat 80 in.
- L.—For angle curves (radius not less than 6 in.) the centres not to exceed the quarter circle and the flats to exceed one-fourth, but not to exceed three-fourths. Example, plate 74 in., bend 18 in., flat 27 in. each side, or about 1/4 in. on one side and 2/10 in. on the other.
- M.—Curves are those which are bent beyond 1 in 4, but not to exceed the half circle (diameter not less than 12 in.). Example, plate 72 in., depth 2½ in., 24 in.
- N.—Curves are for double bends for circular lamp lights, where the openings are not less than 12.
- O.—Curves are for oval light openings, not less than 16.
- P.—Curves are for circles for domes, depth not to exceed 1 in 8. Example, diameter of circle after bend, 48 in., depth 6 in.
- Q.—Curves are those beyond the half circle, with equal straight parts on each side, the flat not to exceed one-fourth, and diameter not less than 12 in. Example, plate 48 in., bend 18 in., flat part 6 in. each side, diameter about 21 in.
- R.—Curves are for ellipses not less than 12 in. diameter, or 6 in. depth of bend.
- S.—Curves not to exceed the quarter of a circle at each side (depth of bend not less than 6 in.) the bent part not less than one-third, and the flat not more than two-thirds. Example, plate 72 in., bend 18 in. each side, centre flat 48 in.
- T.—Curves similar to N but the number of openings less than 12, but not less than 6.
- U.—Curves similar to Q but the number of openings less than 10, but not less than 5.

For plates larger than 26 in. in length, 12 in. in bend, 10 in. curve, or greater depths than 24 in. and difficult curves not mentioned, special prices.

On account of expansion and contraction the curves cannot be guaranteed exact, edges straight, flat parts flat, or not too alike; and with the largest size, deep, double, and difficult bends, the edges are liable to be chafed, and the surface bowed and obscured, but our great experience enables us generally to execute satisfactory bends for all practical purposes, and a fair average, according to the size and curve is guaranteed.

BAXENDALE & CO. LTD.

PLATE GLASS



Plate Glass is one of our specialities. From our very large stocks we give prompt motor deliveries direct on to the job.

Our motors are of a type specially designed for the transport of glass unpacked, and enable us to deliver over a wide area without delay, thus saving customers' time and labour in boarding up windows, handling and returning packages.

THIN AND EXTRA THIN POLISHED PLATE

Can be obtained for special purposes.

THICK POLISH PLATE for Ships' Portholes, and Process Printing Frames and **THICK ROUGH CAST** for Pavement Lights is carried in stock.

GLASS BLOCKS

Standard range of "Insulite" hollow Glass Blocks is carried in stock P.B.2 $5\frac{3}{4}$ in. high \times $5\frac{3}{4}$ in. wide \times $3\frac{7}{8}$ in. thick. P.B.32 $7\frac{1}{4}$ in. high \times $7\frac{3}{4}$ in. wide \times $3\frac{7}{8}$ in. thick.

FULL DESCRIPTIVE LEAFLET SENT ON REQUEST

MILLER STREET · MANCHESTER

PLATE GLASS**WIRED POLISHED PLATE**

with Hexagon mesh or Electrically Welded square mesh wire inserted is obtainable in sizes up to 98 in. × 48 in.

COLOURED PLATE GLASS

Transparent Polished Plate can now be obtained in a variety of tints for decorative purposes and is suitable for Embossing, Silvering, or other embellishment.

OPAL PLATE

Opaque Black with a ground and polished surface, can be obtained in a large range of sizes in the following thickness: $\frac{5}{16}$ in.

ARMOUR PLATE

A specially toughened Plate Glass which is extremely strong, and resists fracture from impact, torsion, or heat, to a great degree. Obtainable in a variety of sizes up to a maximum of 80 in. × 68 in. This cannot be cut or worked once it is made up to required sizes.

THERMOLUX

A laminated type of Glass embodying an interlayer of Glass Silk. Useful for many commercial and scientific purposes owing to its special properties of perfect and even light diffusion, resistance to shattering, and its special acoustic properties.

WORK ON GLASS

We carry out at our Glass Works every type of work on the surface or on the edges of glass, including polished plate, coloured plate, plain and coloured opaque glass, etc.

SURFACE WORK includes Silvering, Gilding, Embossing, Engraving, Brilliant Cutting, Sandblasting, or combinations of the above.

EDGEWORK includes Bevelling, Grinding, Smoothing and Polishing of edges, Mitre Bevelling for Frameless Shop Fronts, Showcases, etc.

Glass is now used for an infinite variety of special purposes such as wall-lining, decorative and lighting schemes, covering of furniture or valuable fabrics, etc., and we shall be glad to work out Architects' plans and suggestions for any special need.

ADVERTISING SIGNS, ETC.



Shop Fronts with raised or incised lettering on facias—including Glass or Vitrolite for Fascias, Transoms, Stall Risers, and Pilasters.



No. D.G. 481
Glass, Vitrolite or Plastic
Hanging Signs.

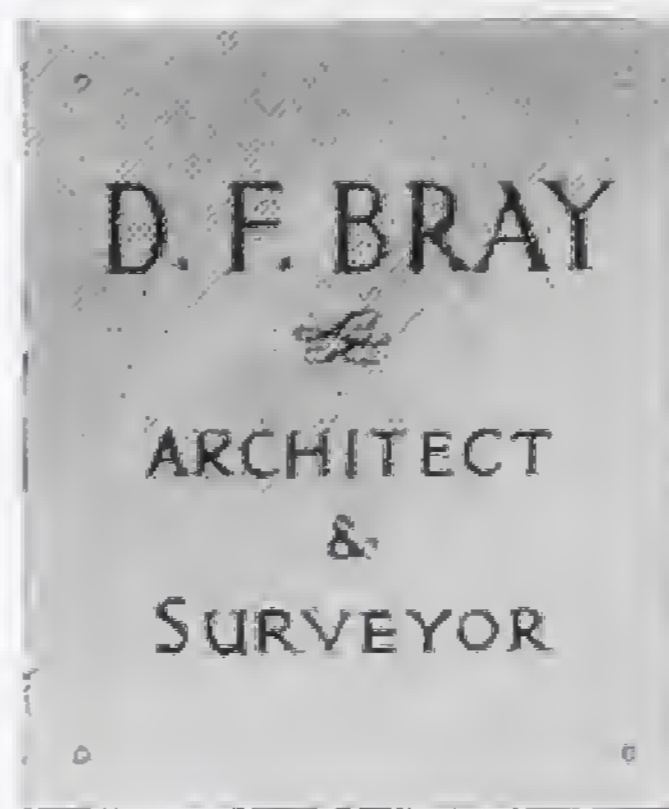

No. D.G. 483
Vitrolite or Glass Name
Plates with sandblasted
lettering.



No. D.G. 482
Decorative Door Panels
with sandblasted designs.



No. D.G. 484
Brewers' Tablets — on
Vitrolite or Glass with
sandblasted lettering, etc.

A coloured drawing of any fascia can be supplied for your customers' approval.



No. D.G. 486
Plate Glass Name Plates,
bevelled and silvered.

EMBOSSSED AND BRILLIANT CUT GLASS



No. D.G. 476
Embossed plate with stipple embossed gold letters.



No. D.G. 477
Embossed and brilliant cut.

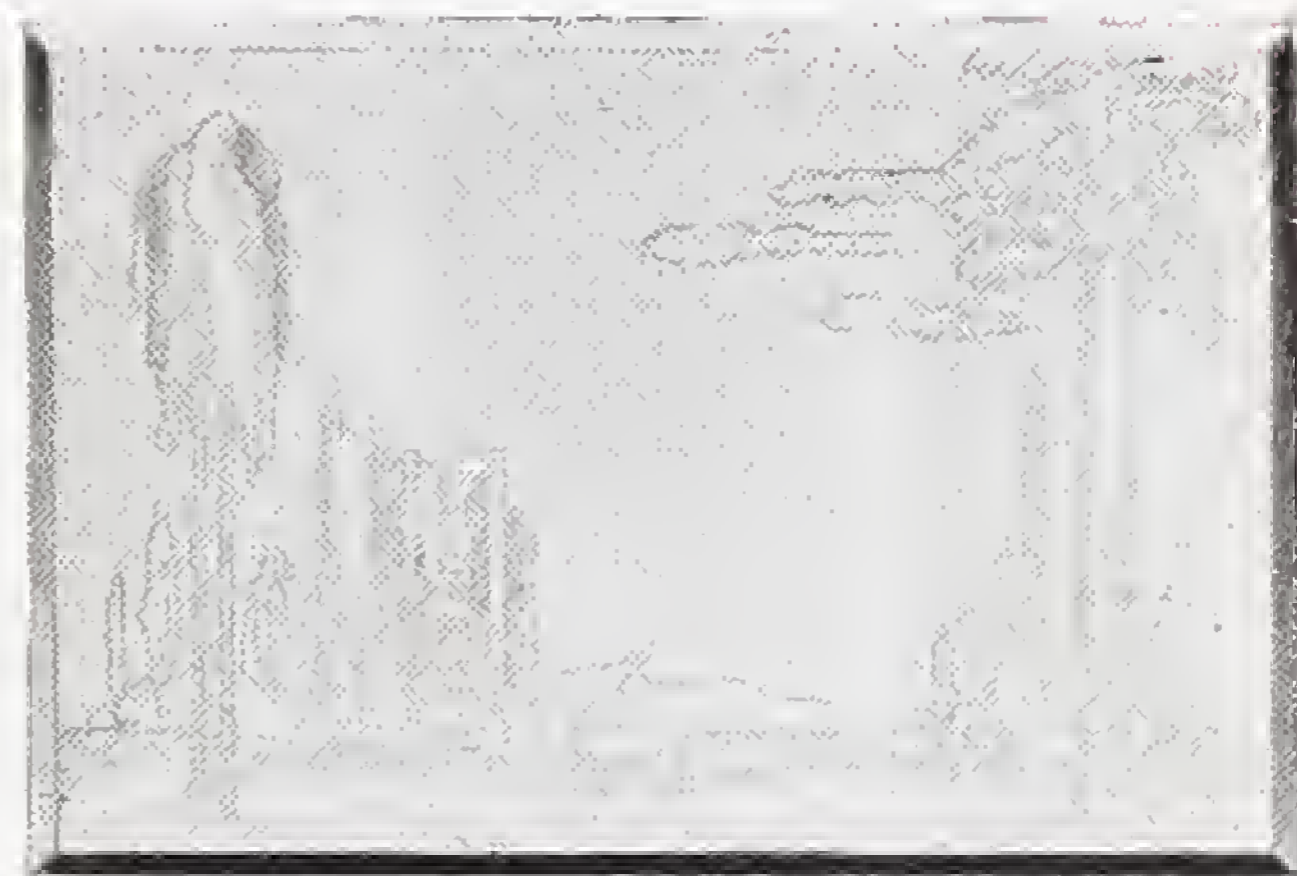

No. D.G. 478
Acid embossed pictorial design for partitions or mirrors.



No. D.G. 480
Brilliant cut embossed and bevelled.

We shall be pleased to submit special designs to suit customers' requirements on receipt of full particulars.



No. D.G. 479
Brilliant cut and bevelled door panel.

LETTERS, SIGNS AND LABELS



No. D.G. 487

No. D.G. 488

No. D.G. 489

No. D.G. 490

Plastic (built-up and moulded) Stainless Steel, Bronze, Bronze and Vitreous Enamel
Wood and Copper Letters for all Signs



No. D.G. 491

Embossed, silver and black Plate Glass Door Number



No. D.G. 492

Door Numbers in Bronze, Plastic, Iron, Chrome, Brass and Aluminium.

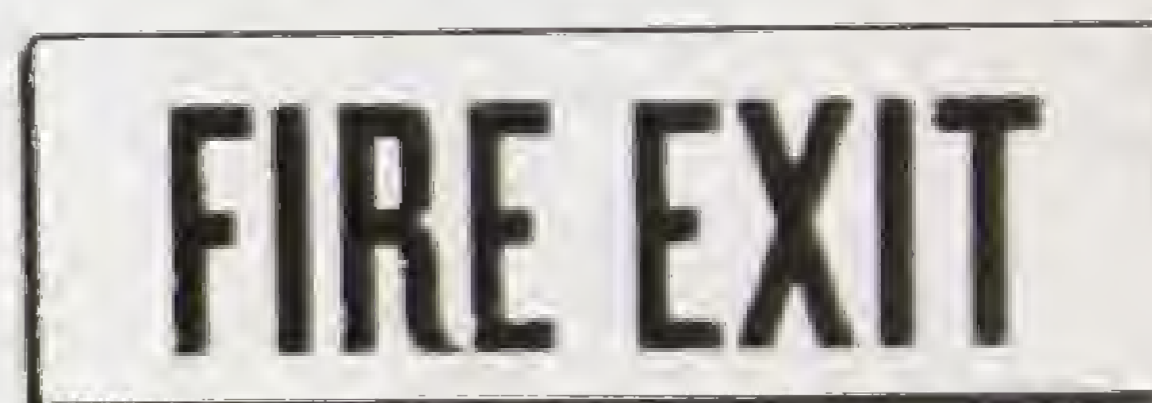

No. D.G. 493
Vitreous Enamel on Iron.



No. D.G. 494
Cast Bronze or Aluminium.

These illustrations show only a few of our many designs.

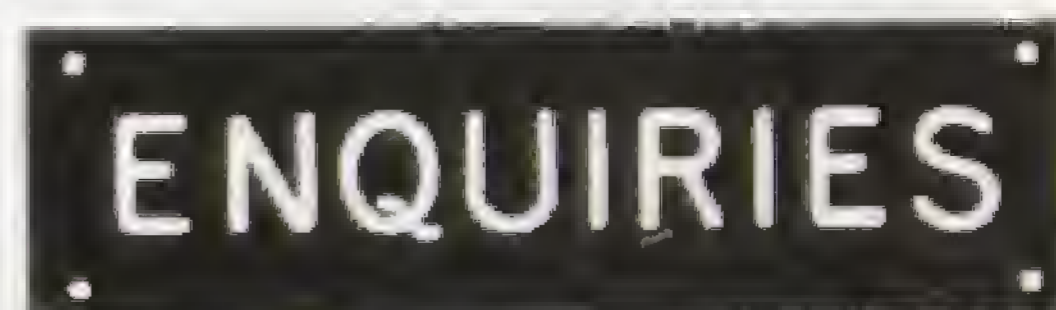

No. D.G. 495
Bronze Plastic.



No. D.G. 499
Unit signs (with loose letter).



No. D.G. 498
Bronze, Plastic or Glass Push and Pull Plates.



No. D.G. 496
Bronze and Vitreous Enamel.



No. D.G. 497
Copper Repousse.

ADVERTISING LAMPS
For Electric Light

No. V 987. W.I. BRACKET
 $\frac{1}{2}$ in. Arm. 18 in. projection.
Bracket only

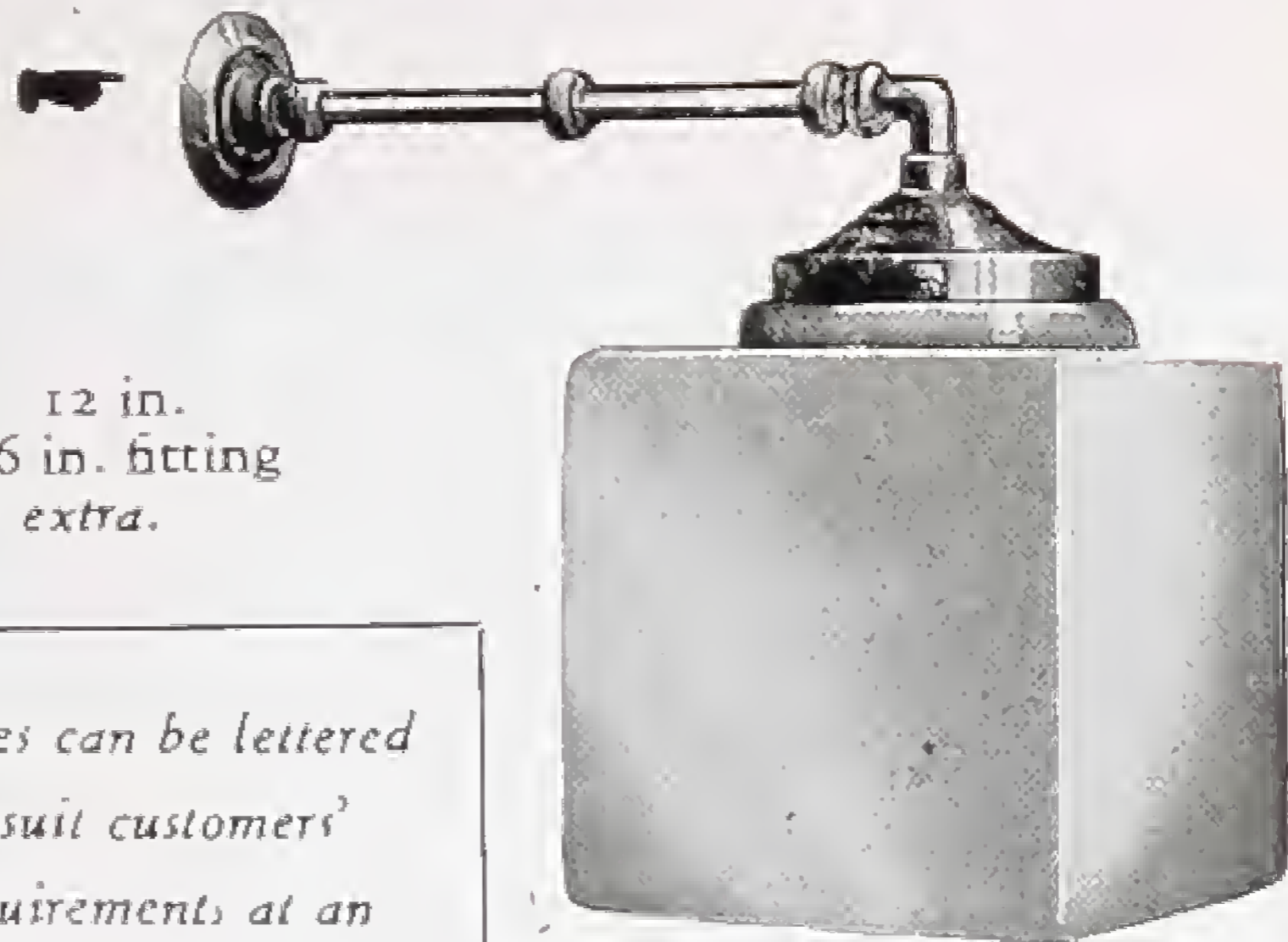

No. V 920
OPAL CASED GLOBES

6	8	10	12 in.
4	4	5	6 in. fitting

Globe Gallery *extra.*

*Globes can be lettered
to suit customers'
requirements at an
extra charge.*



Nos. V 970
and
V 940

No. V 970
W.I. BRACKET
WITH WALL
STAY

$\frac{1}{2}$ in. Arm.
18 in. projection.
Bracket only

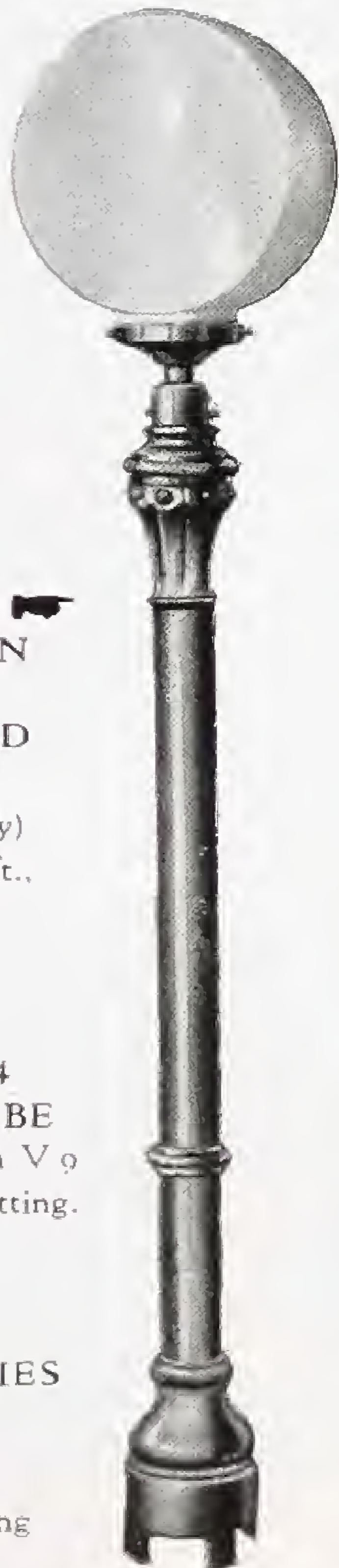

No. V 940
12 in. OPAL CASED GLOBE
Square shape.
9 x 7 in. panels, $7\frac{1}{2}$ in. fitting.
Globe Gallery *extra.*
(Lettering *extra.*)

No. V 9
CAST-IRON
LAMP
STANDARD
Painted.
(Standard only)
4 ft. 6 in., 5 ft.,
5 ft. 6 in.

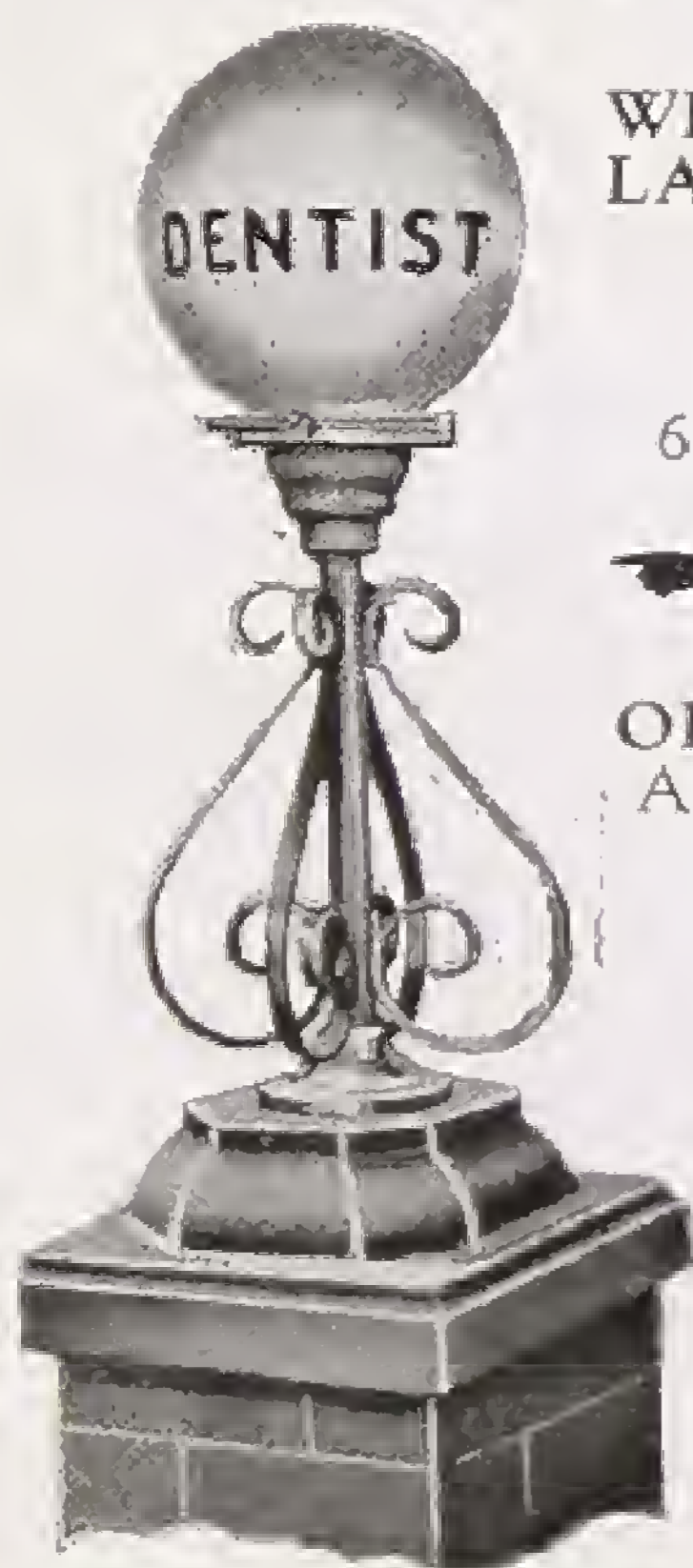

No. V 913
WROUGHT IRON
LAMP STANDARD
15-in. high, with
4-way Scroll and
Cast-iron Gallery.
6-in. fitting. Painted.
Standard only

No. V 931
OPAL BALL GLOBE
As illustrated on V 913
Globe only.
12 in.
(Lettering *extra.*)

No. V 954
OPAL GLOBE
As illustrated on V 9
16 in. 6 in. fitting.

CAST-IRON GLOBE GALLERIES
Also Supplied
With or Without Globe Rest

$3\frac{1}{2}$ 4 5 6 8 in. fitting

LEADED LIGHTS

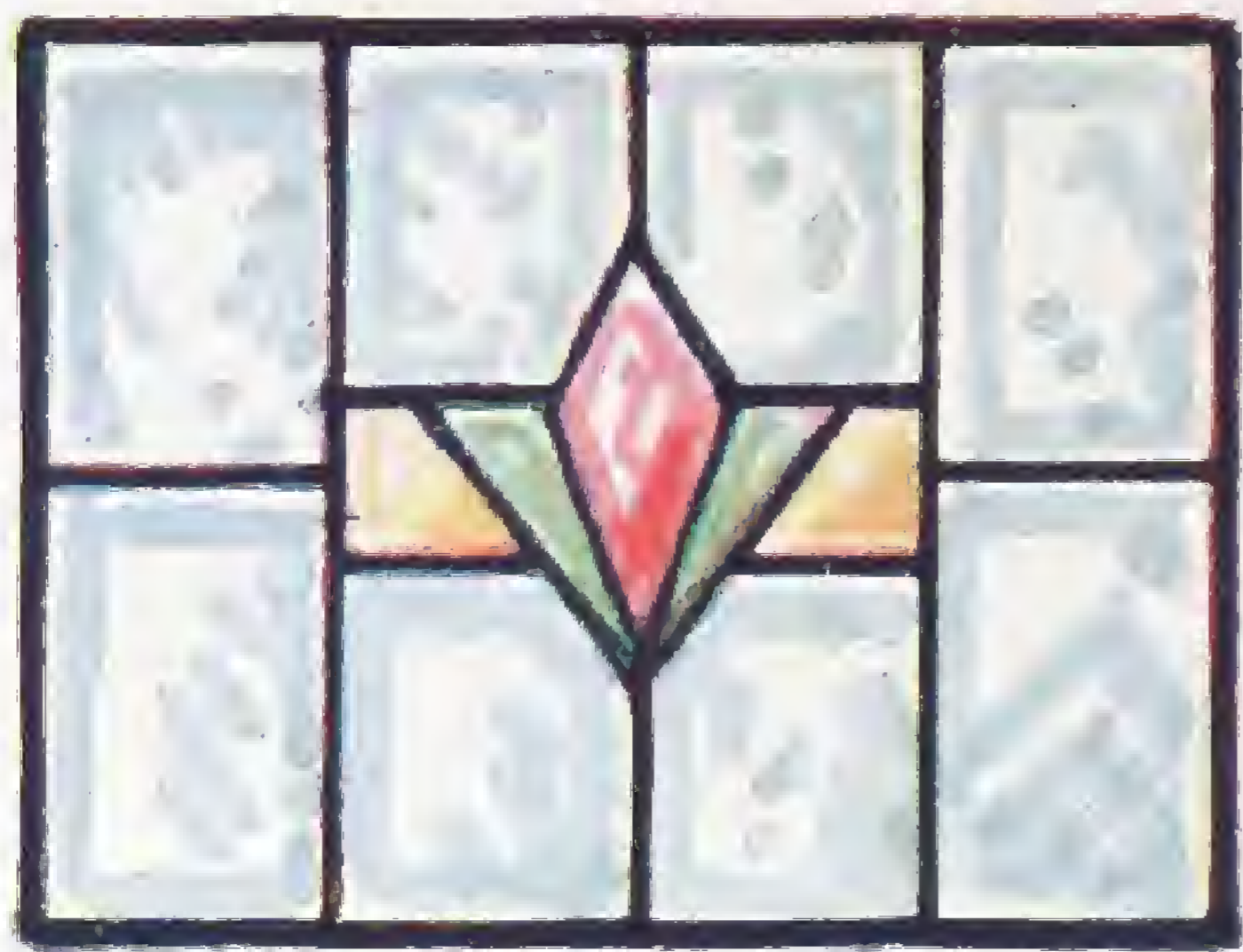

DG. 21



DG. 22

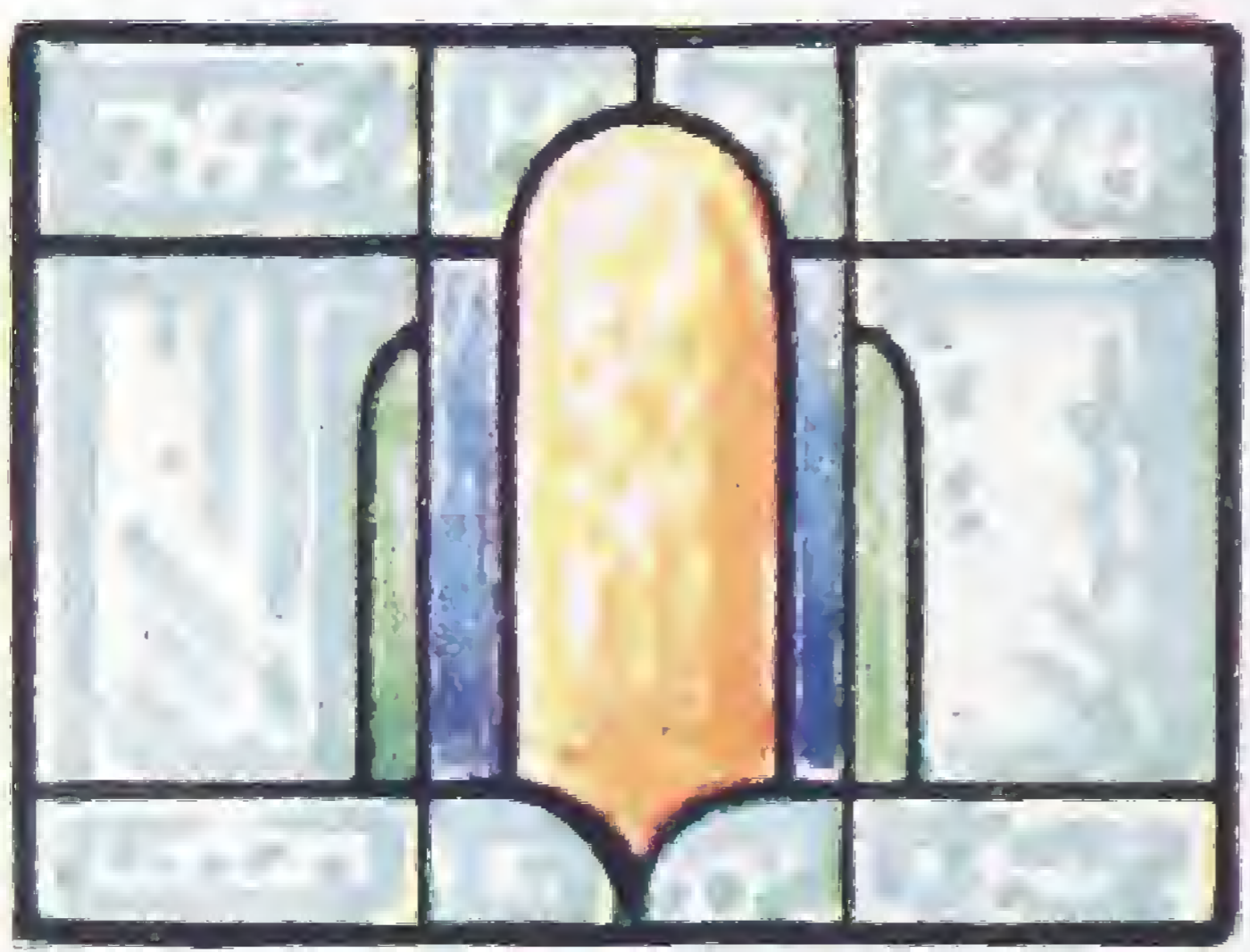

DG. 23



DG. 24.

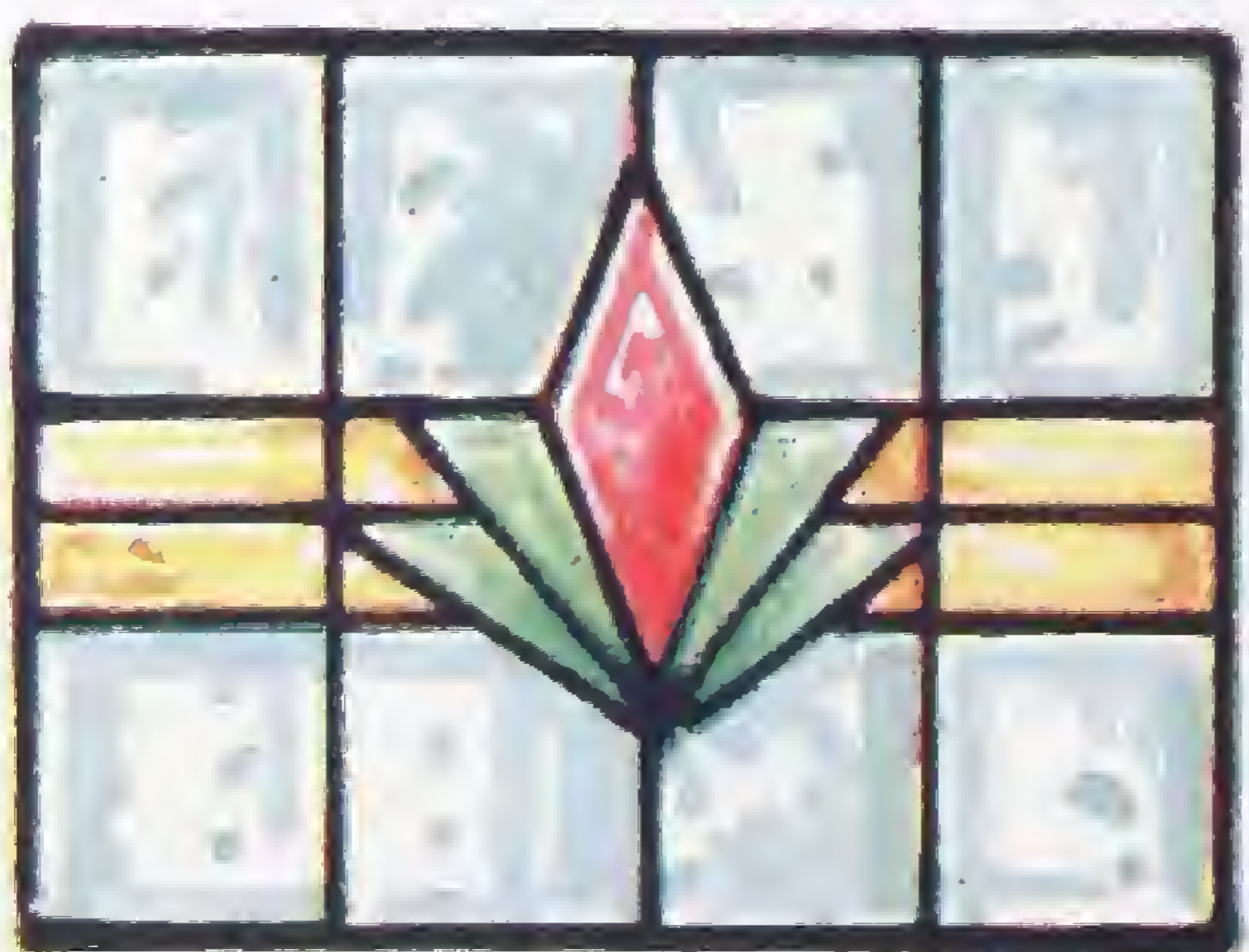

DG. 25



DG. 26

LEADED LIGHTS



DG. 27

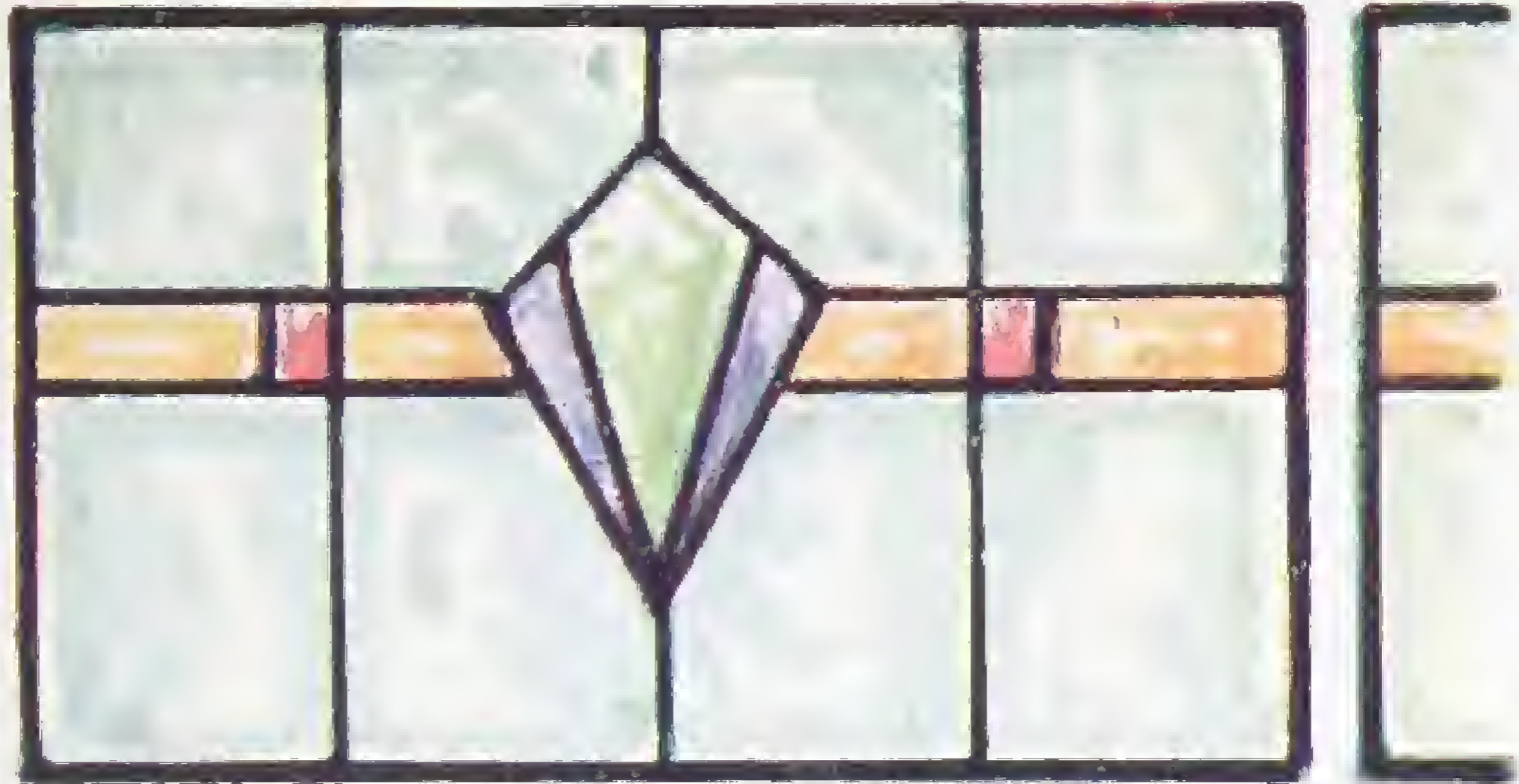

DG. 28

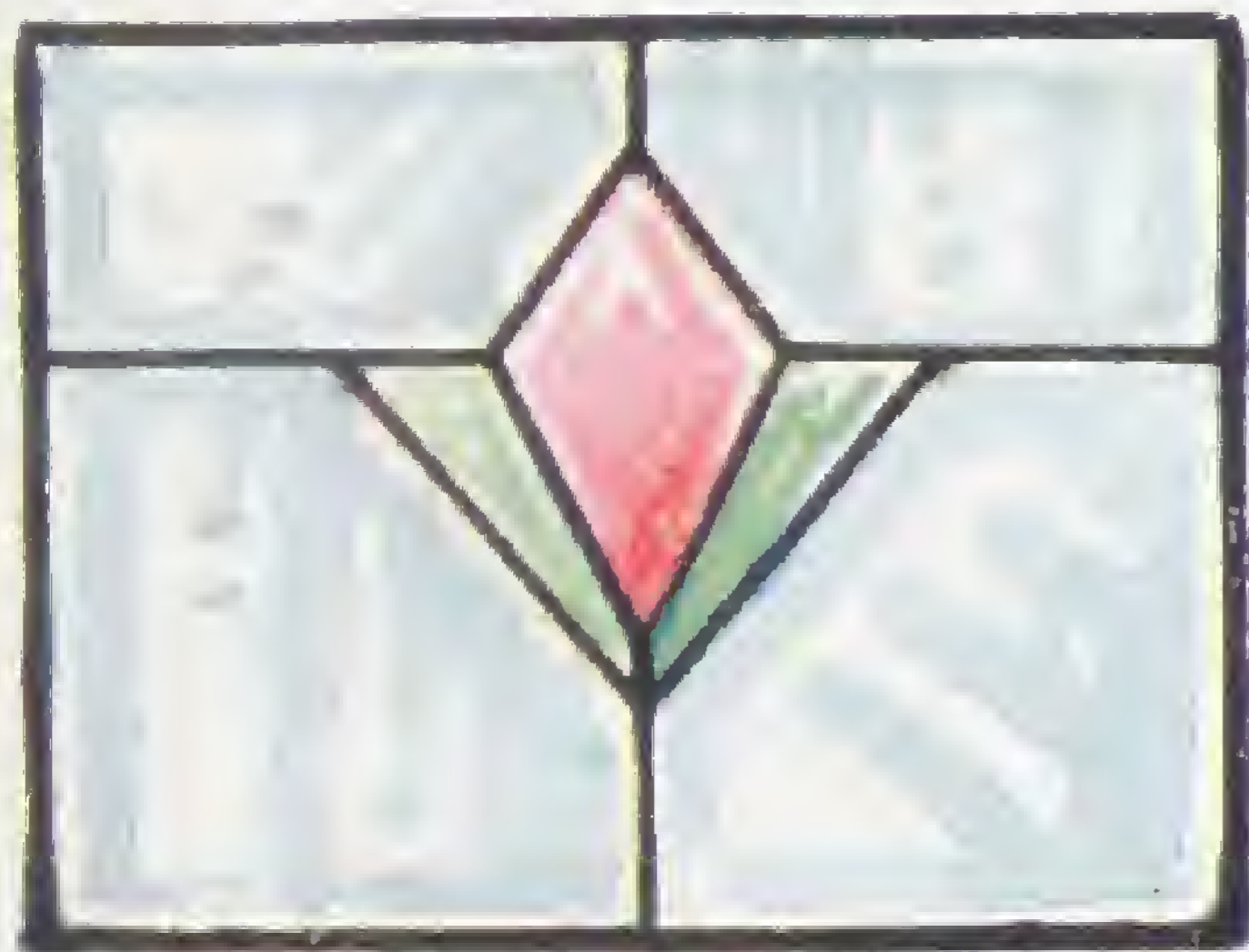

DG. 29

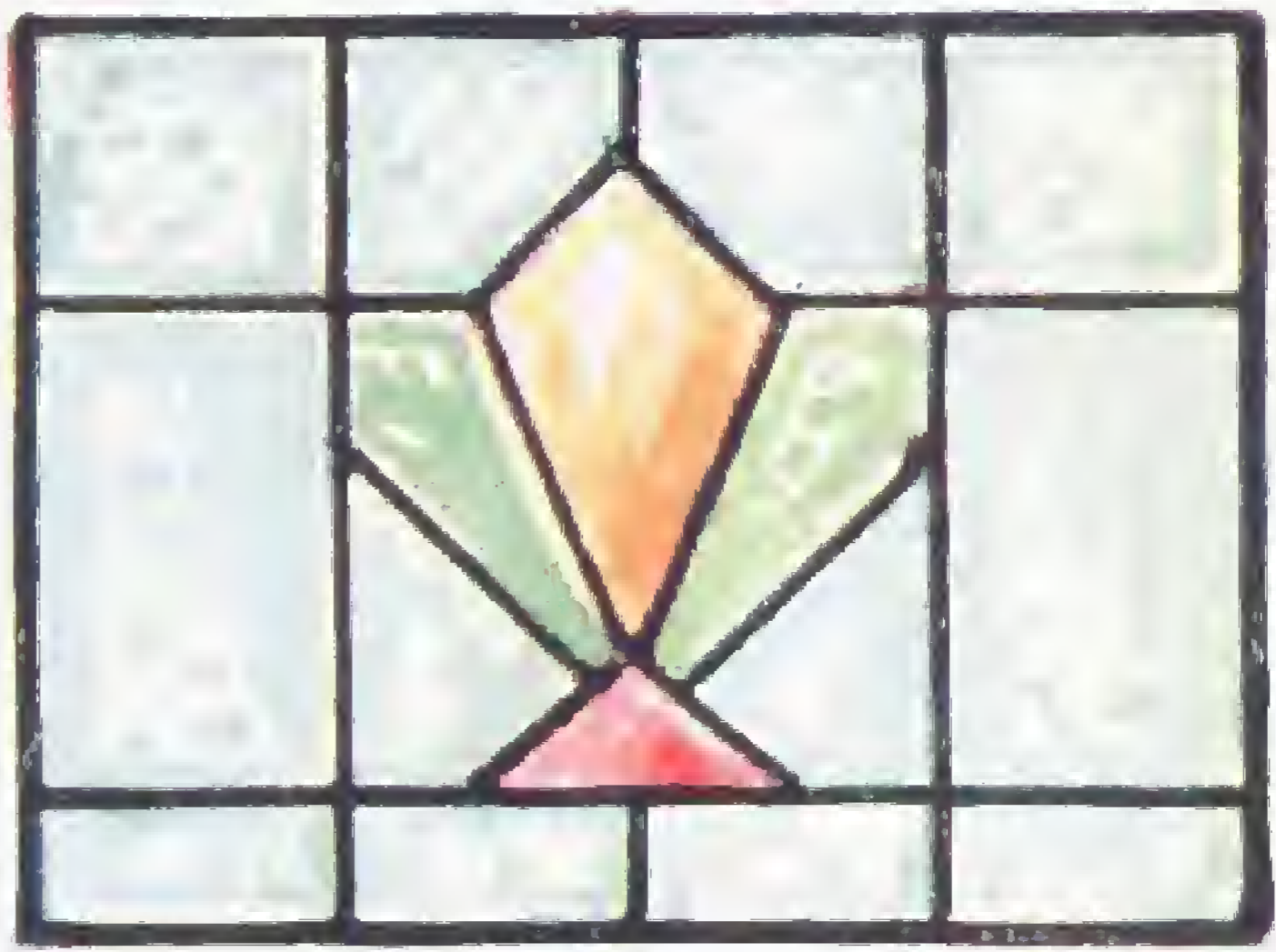

DG. 30

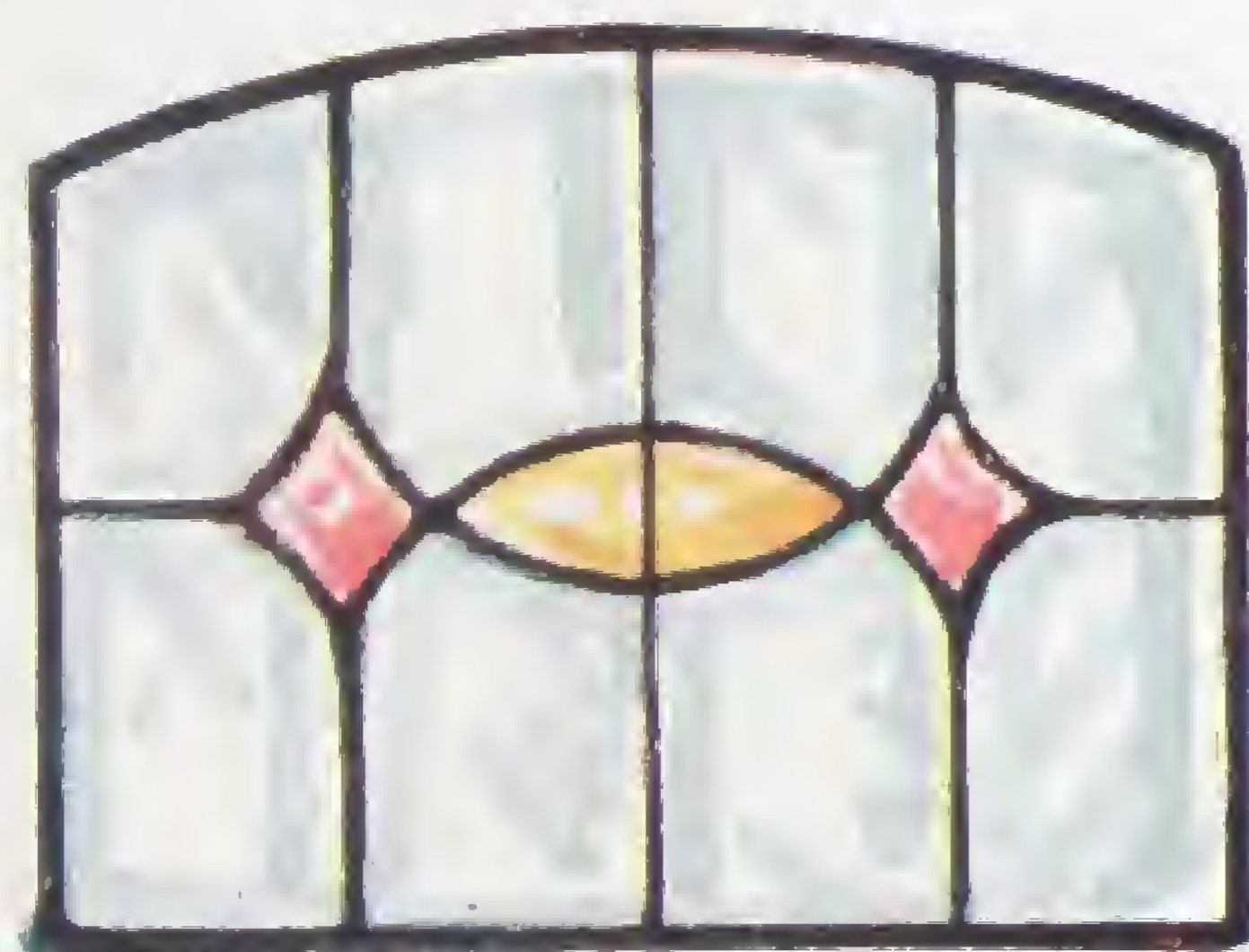

DG. 31



DG. 32

LEADED LIGHTS

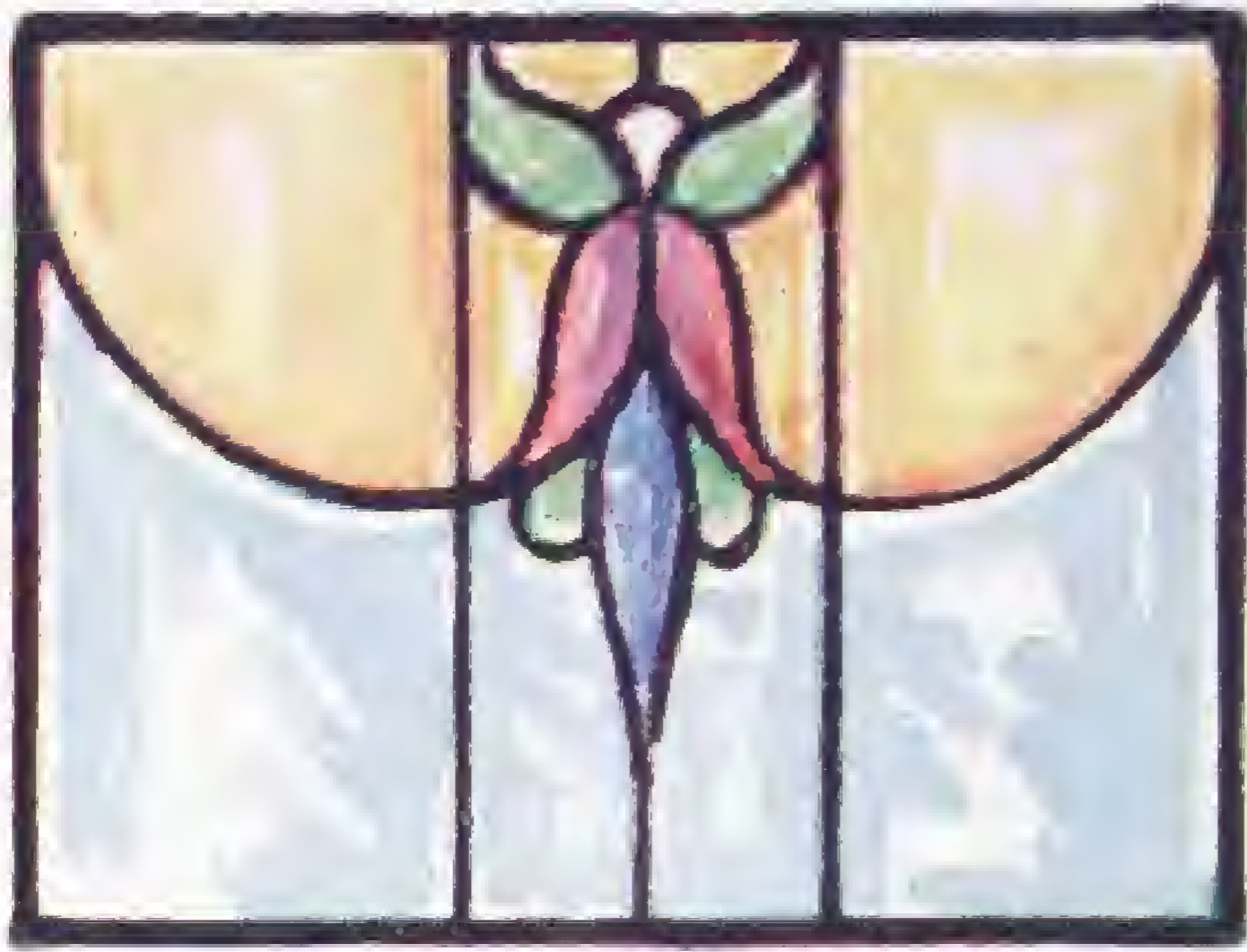

DG. 33



DG. 34

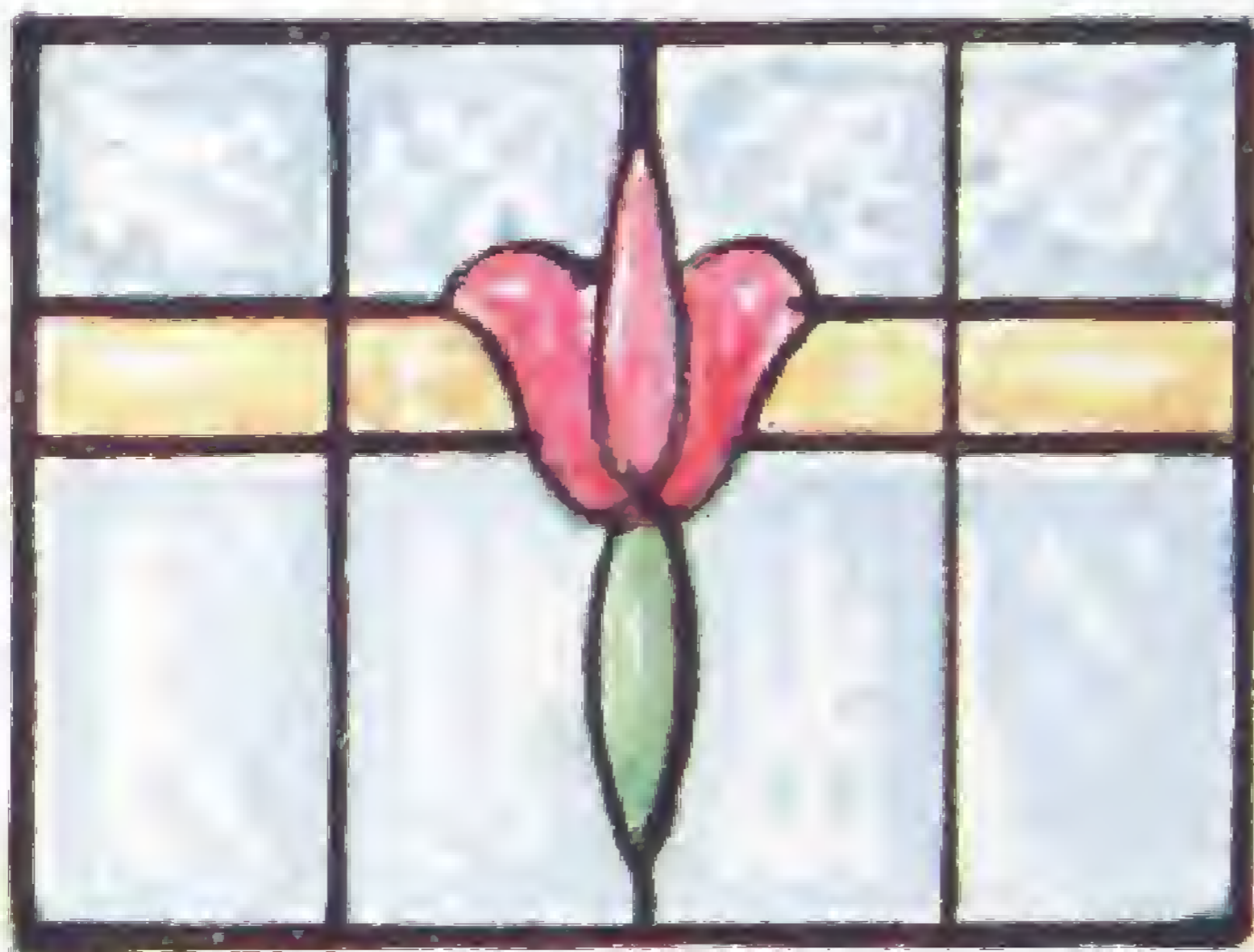

DG. 35

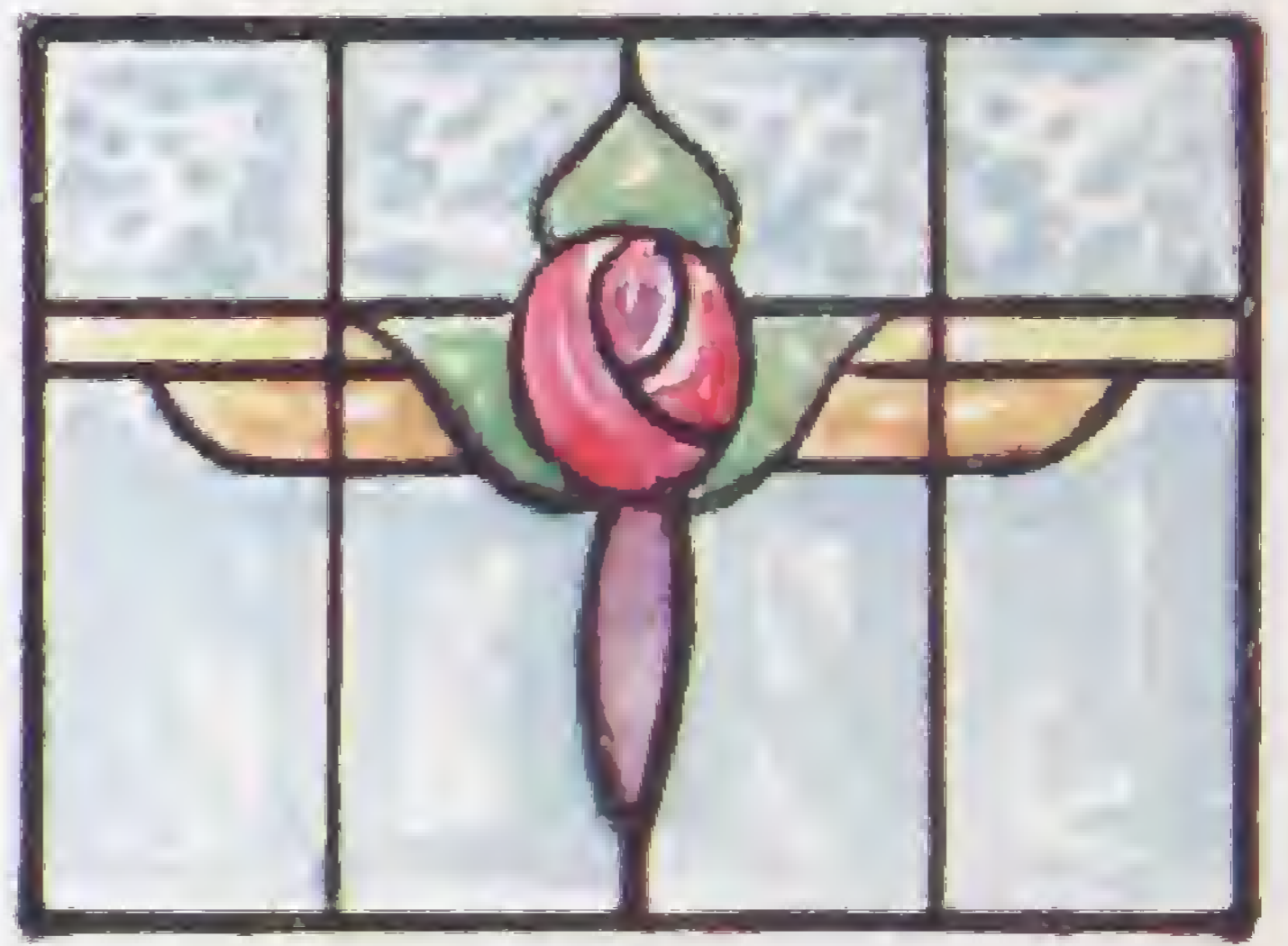

DG. 36

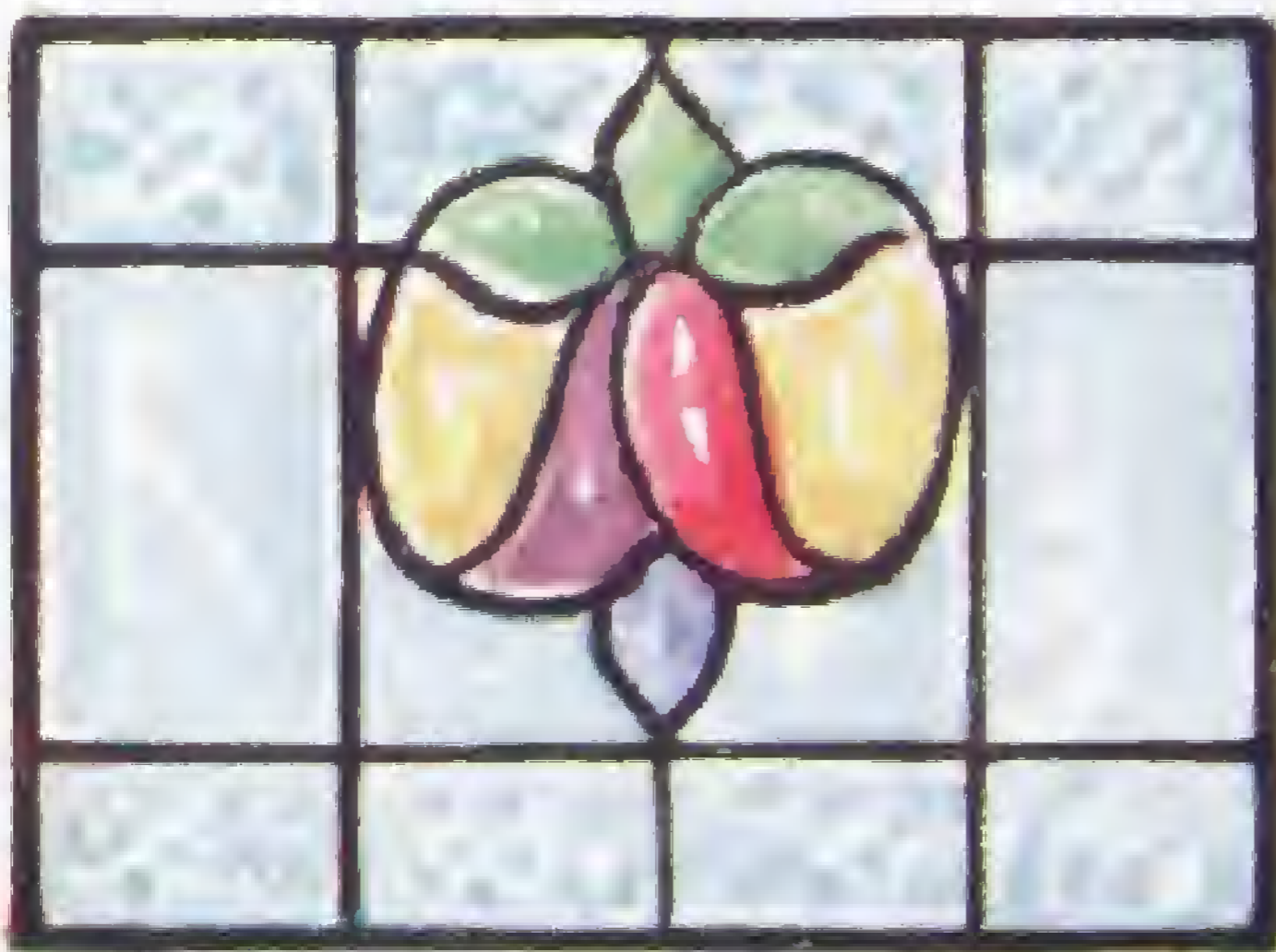

DG. 37



DG. 38

LEADED LIGHTS



DG. 39



DG. 40



DG. 41



DG. 42

"BAXINOL" SUPER GLOSS FINISH PAINT

For Outside and Inside.



A Durable Finishing Paint ready for use, giving a lasting high Gloss.

Having good body and covering power, it flows out easily and smoothly under the brush, and because of the reduced number of coats required it CUTS DOWN THE LABOUR BILL, besides effecting a saving of material, thus ensuring a considerable economy in cost but giving first-class results.

Is hard wearing and gives excellent protection against corrosion. No Varnish is needed for "BAXINOL" SUPER GLOSS FINISH PAINT, and one coat produces better results than one coat of Paint and one of Varnish.

Made in White, Black, and 18 Standard Shades, but any colour can be supplied.

"BEANCO" GENUINE WHITE LEAD LIQUID PAINT

For Inside and Outside Use. Suitable for all classes of work.

Made from
GENUINE ENGLISH
WHITE LEAD
AND GENUINE LINSEED OIL
WITH BEST PATENT DRIERS

It is carefully prepared by special machinery, and it will be found absolutely Reliable and Durable.



Made in Flat, Gloss, and Semi-Gloss.

Packed in $\frac{1}{2}$ gallon tins.



**“BEANCO”
FINEST READY MIXED PAINT**

No. P 579

For Inside and Outside Use.
Mixed Ready for Use.

These Paints are made of the Highest Grade Materials, and are recommended for Uniformity, Covering Power, and Durability.

Supplied in 16 tints.

Packed in $\frac{1}{2}$ pint to $\frac{1}{2}$ gallon Lever-top Tins.

“BEANCO” ALUMINIUM PAINT
No. P 580

Made from Pure Aluminium Powder. Will stand more heat than any ordinary paint or enamel, will not blister, or peel off. Has immense covering power.

“BEANCO” WHITE ENAMEL
No. P 581

For Interior and Exterior Use.

“BEANCO” White Enamel is of excellent quality and gives a finish equal to porcelain tiling.

“BEANCO” White Enamel is a free-flowing Enamel which will not crack. It can be used anywhere and in any position. It is Snow White in appearance, and has no blue tint; dries with a perfectly smooth, hard, and brilliant surface of extreme durability. Economical in Use.

“BEANCO” White Enamel has a covering capacity of about 80 square yards per gallon over a properly prepared surface.

“BEANCO” WHITE ENAMEL (For Baths)
In $\frac{1}{2}$ pint and 1 pint tins.



**RATCLIFFE'S
OIL SCUMBLES**

For figure and brush graining, glazing, etc.

Rich permanent and strong Colours.

Do not require expensive grounds.

They work easier, streak better, and go farther than any Graining Colours.

Once the ground colour is dry, work can be scumbled and varnished the same day
No waiting for drying.

In 1 lb. and $\frac{1}{2}$ lb. tins.

Rosewood, Mahogany and Green

Light Oak, Satinwood, Medium Oak, Pitch Pine, Dark Brown, Antique Oak, Fumed Oak, Bog Oak, Walnut, Jacobean Oak, Old Oak, Zebra-wood, Black and Grey.

Water Scumbles also available in same colours.

DRY COLOURS

For all Purposes :—Distemping, Scenic requirements, Tinting, Blending, Mixing, etc.
Also for Cement mixtures and general contracting

COLOURS, in OIL, TURPS and WATER

All the standard colours and shades can be supplied and many of the specialities for graining purposes.

Particular attention is paid to fine grinding.

WHITE LEAD

White Lead sold under our brand "BEANCO" is Double Ground. Beside being noted for its Fineness of Texture in the paste form, it is superior in colour, and has Greater Covering Power than ordinary ground White Lead.

"BEANCO" WHITE LEAD IS STACK-CORRODED, AND ENGLISH.

FINEST DRYERS (Paste)

Liquid (Turpentine)

FINE COLOURS in Collapsible Tubes

FOR HIGH-CLASS DECORATING. GROUND IN OIL.

HOW FAR PAINTS WILL SPREAD

An Authority on paints, after making a series of carefully-conducted experiments gives the following figures, which represent the number of square feet covered by 10 lbs. of paint of the usual consistency, applied evenly with a brush.

ON WOOD	First	Second	ON METAL	sq. ft.
	Coat	Coat		
	sq. ft.	sq. ft.		
Red Lead	112	152	Red Lead	477
White Lead	211	314	White Lead	648
Oxide of Zinc	278	451	Oxide of Zinc	1,114
Red Oxide	451	540	Red Oxide	870
Raw Linseed Oil			Raw Linseed Oil	
(no pigment)	756	872	(no pigment)	1,417
Boiled Linseed Oil			Boiled Linseed Oil	
(no pigment)	411	540	(no pigment)	1,396

GOLD LEAF, Etc.

For Carvers, Gilders, Sign Writers, Decorators, etc.

P 710—Best deep English Gold Leaf. Loose.

P 711—Best deep English Gold Leaf. Transferred on to tissue paper, for sign writers' and decorators' use.

BEANCO POWDERED DISTEMPER FOR WALLS AND CEILINGS

No. P 730

An economical and cheap Powdered Distemper requiring mixing with water only.

Packed in convenient form for handing out with the minimum of trouble for retailing purposes, or for small jobs, where the correct quantity can be given without waste.

20 Artistic Shades.

Packets of approx. 3 lb.



ARDURO WATER PAINT

(Regd.)

WASHABLE, ECONOMICAL, DURABLE,
ARTISTIC AND SANITARY

ARDURO has been proved, after many years, to be the premier Water Paint.

It is made up in paste form and is readily mixed with cold water. After application, Arduro dries perfectly flat, giving a rich decorative and artistic effect which is greatly appreciated by architects and decorators.

ARDURO will not rub off as do most distempers.

ARDURO is not a distemper. It acts as a disinfectant. It can be varnished. It has many advantages over similar preparations, giving perfection of surface with great durability. It is easily applied.

Directions for applying.—It will be necessary to remove all old size, whitening or limewash materials, thus securing a clean ground before using Arduro. In preparing Arduro the following proportions will be sufficient to mix it to a working consistency:—One pint of water per 7 lbs. of Arduro or half-pint of water per 4 lbs. If more water than above is added, the washable properties are reduced, and the work may not come out solid.

Repairs in plaster, where needed, should be executed with a mixture of plaster and body-colour Arduro to shade of walls, or on new work to finishing coat. After the first coat, touch up with the solid material. Where repairs have been executed previously by plasterer, these should be touched up after first coat with flat colour of the finishing shade.

Nos. 215, 218, and 220 are not lime-resisting, and should not be used on new plaster.

ARDURO LIQUID

A special preparation used as a petrifying agent with Arduro body colour, especially for outside work, curing the suction of porous surfaces. It is colourless, and therefore will not alter the tint of the paint. Supplied in a specially concentrated form to arrest decay in brick and stone.



VARNISHES, Etc.

All thoroughly matured, carefully tested, and reliable.

P 617

"BEANCO" ALL-PURPOSE FINE COPAL VARNISH

For Outside and Inside Use

Dries thoroughly hard, with a first-class gloss which is lasting and durable. Guaranteed to stand rain and damp without blooming. Not affected by frost and will withstand the hottest sun without cracking.

In gallon, $\frac{1}{2}$ gallon and quart tins.

P 618

PAL-AM-VAR

Pale-Amber-Varnish

Pure Gum Free from Resin.

Pale in colour and of good lustre. Hard-wearing, and dries in a few hours.

In two qualities for INSIDE or OUTSIDE.



SPIRIT VARNISHES, STAINS, POLISHES, Etc.

P 632—White Hard Spirit Varnish.

P 633—Brown Hard Spirit Varnish.

P 634—French Polish.

P 635—White Polish.

P 636—Transparent Polish.

P 637—Button Polish.

P 638—Patent Glaze, for finishing.

P 640—Shellac Varnish.

P 641—Spirit Stains, for Staining Wood.
(Flat or Varnish)

P 643—Coffin Varnish. A quick drying Varnish.

P 645—Methylated Spirits, and Finish.



POLISHERS' SUNDRIES

Dry Raw Sienna

Dry Burnt Sienna

Dry Vandyke Brown
(Powdered and Crystals)

Bichromate of Potash

Polishing Rags

Gum Benzoin

Orange Shellac

White Shellac

Button Shellac

Spirit Aniline Stains in all colours

Mahogany Crystals

Wood Filler

Glues

Gum Sandrac

Sand Paper

WOOD STAINS, ANILINE CRYSTALS and DYES

P 650—In powder, in Mahogany, Oak, Walnut, Rosewood, and Ebony.

PAINTERS' SUNDRIES

SPONGES

No. P 932

Large stocks in all grades and in sizes suitable for all work, i.e., for Painters, Motors, Carriage Builders, etc.

CHAMOIS LEATHERS

No. IR 5900

Carefully selected, best quality.
Full Range of Sizes Stocked.

SOAPS

Carbolic Soap (bars), Household Soap, Pale (in bars), Soft Soap (pale Amber), in $\frac{1}{2}$ cwt. net weight drums, Concentrated Liquid Soap.

PUMICE STONE, Etc.

Lump Pumice, selected pieces for Painters, Coachbuilders, etc.
Artificial Pumice Blocks in various grades.
Pumice Powder.

GLASS PAPER AND EMERY CLOTH

Glass Paper and Glass Cloth.

No. 0 to F2, M2—S2, $2\frac{1}{2}$ —3.

Emery Cloth 00 to $1\frac{1}{2}$, 2 to 3.

WATERPROOF FLINT PAPER

Perfectly waterproof—can be soaked in water indefinitely—the back is finished so as to give a good grip to the hand and not slip when wetted.

In sheets 9 in. by 11 in.

EMERY POWDER, in all Grades.



OIL DRUMS

No. P 861

Safe Economic Clean

Made of terne coated steel. Designed for the storage of oil for all purposes, especially for use in connection with Heaters and Cookers.

Fitted with filling bung, with brass ring and leather washer at top, and $\frac{1}{2}$ in. tap fitted at bottom.

An economical container for general household use ; keeps oil free from dust and dirt, and provides a quick and easy means of filling lamps and stoves.

5 gallon size :

17 in. high \times 10 $\frac{1}{2}$ in. diameter

10 gallon size :

20 $\frac{1}{2}$ in. high \times 13 $\frac{1}{2}$ in. diameter



**BEANCO GENUINE LINSEED OIL PUTTY
MADE FROM BEST WHITING AND
PURE LINSEED OIL.**

Special attention is given to the manufacture of this, and any quantity, small or large can be supplied. We can also make up to order or specification any special mixture or colour to suit customers' requirements for any purpose.

In 1 cwt., $\frac{1}{2}$ cwt., and $\frac{1}{4}$ cwt. kegs,
and smaller quantities as required.

"BEANCOLITE"

(Trade)

PRESERVATIVE WOOD STAIN

Prevents Decay, Dry Rot, and Fungoid Growths in all Timber.

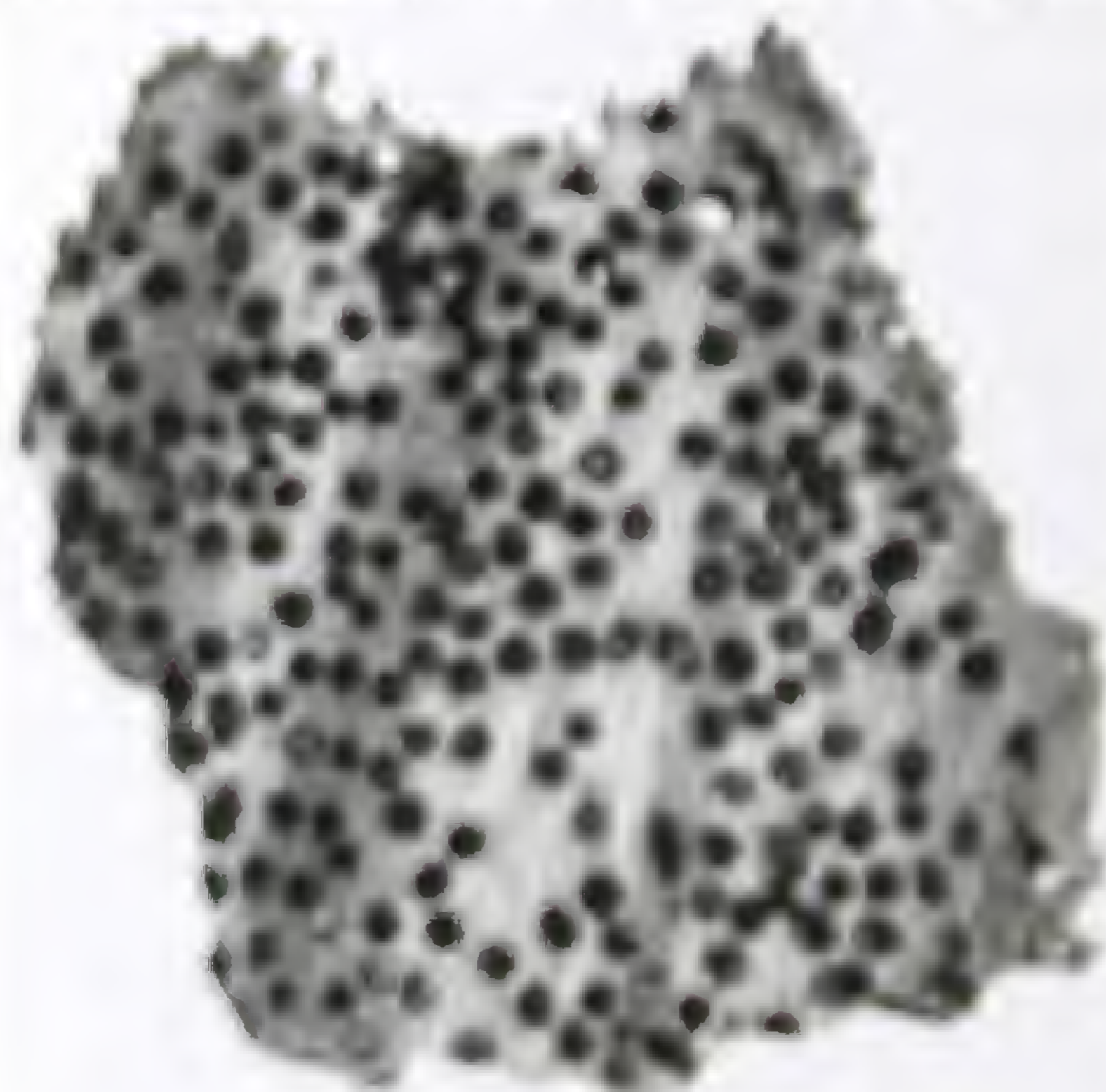

*An untreated piece of wood
shows its actual characteristics.*

Invaluable for the Preservation of Beams, Posts, Joists, Headings, Sills, etc., and Wooden Portions of every kind; also for Wood Paving Blocks, etc.

Woodwork impregnated with Beancolite is effectually preserved against the effects of **Dampness** and Exposure and is also protected against the ravages of insects.

Specially recommended for timber used externally or partly underground.

Beancolite makes it possible to secure Artistic effect, with Absence of decay. The beautiful nut-brown stain secures the one, and the disinfectant preservative element, the other.

Method of Application. Apply by brush liberally to secure absorption of as much of the preparation as possible. If applied hot greater penetration is secured. Where possible immersion or better still.

CUPRINOL

SOME OF ITS MANY USES

The following list gives a general indication of the uses of the various grades of Cuprinol :—

Boat-building.—Green for Timber (or Oak or Clear).

Building Construction.—Green for Timber (or Oak or Clear).

Canvas.—Texaprufe or Proofer No. 3.

Deck Chair Canvas.—Texaprufe.

Dry Rot.—Green for Timber.

Fences.—Brown for Timber (Heavy Duty).

Fishing Nets and Lines.—Green or B.C. Green for Fishing Nets.

Floor boards.—Cuprinol Oak or Clear or Cuprinol Wood Dyes.

Forcing Frames.—Green for Timber.

Garden Nets.—Texaprufe.

Gate Posts.—Brown (Heavy Duty).

Garden Furniture.—Oak or Clear for Timber.

Glasshouses.—Green—this may be painted if required.

Joinery.—Green or Clear for Timber.

Portable Buildings.—Brown (Heavy Duty). If the wood-work is to be painted use Standard Timber Grade.

Ropes.—Texaprufe or Proofer No. 3.

Seedboxes.—Green for Timber.

Shop Blinds.—Texaprufe Clear.

Sports Nets.—Texaprufe.

Tarpaulins.—Texaprufe or Proofer No. 3.

Woodworm in Furniture or Structural timbers.—Cuprinol Woodworm Killer.

Yacht Sails.—Texaprufe.

"RENTONIL"

Timber Fluid: "A" for polished woodwork
 "B" for untreated beams, doors, etc. "C"
 for use when wood is treated (quick-drying).
 Also for surfaces already painted. Surfaces can
 be treated or polished soon after treatment.



You can't keep Dry-Bre. You cannot afford to ignore Dry-Bre. You don't buy bags or the like any more. Large-scale structural repairs need not be temporary. There is an answer: Rentonil Dry-Bre Fluid—immediate, permanent, non-flammable, almost instantaneous and on occasion permanent, a brilliant effective answer Dry-Bre. What that and other things make. Also all woodwork a permanent treat-ment with Rentonil Dry-Bre Fluid without delay.

OIL CABINETS

The Cabinet is made of Flashed Sheet with
 Galvanized Iron Interior, and Enamelled
 Bright Steel.
 It stands up, and is UNSTOPPABLE, and being
 so is suitable for a kitchen, bar, or shop.
 There is never any leakage with Cabinets.
 Cabinets come in Two
 and sometimes even back into the Cabinet.
 What a Cabinet the latest one is, is a
 permanent, permanent, and the latest
 solution. The use of Cabinets means
 cleanliness and freedom from all dirt.
 The saving of leakage for the use of a
 Cabinet will pay for it in a short time, and
 also prevent all danger.



No. P 800
 Cabinet Open

Capacity Imperial Gallons	Height inches (including lid)	Diameter
4 gallons	24 1/2	14 1/2
6 "	27 1/2	16 1/2
8 "	30 1/2	18 1/2
10 "	33 1/2	20 1/2
12 "	36 1/2	22 1/2
14 "	39 1/2	24 1/2
16 "	42 1/2	26 1/2
18 "	45 1/2	28 1/2
20 "	48 1/2	30 1/2



BETEX DAMP WALL PREPARATION

Betex is clean, harmless, and has no deleterious action whatever. In exposed positions especially, the weather conditions—wind, rain, frost, and sun—are continuously playing their part in disintegrating the material of which the property is built.

The appearance of the building, whether brick, stone or concrete, is not altered. Betex soaks into the porous surface, remains there as an invisible barrier to moisture, acting as a binding material, thus preventing deterioration or decay.

BETEX should be applied when the weather is dry, and the surface to be treated should be as dry and absorbent as possible to get the most successful result. We recommend two applications.

IN TWO HOURS IT WILL BE FOUND THAT NO MOISTURE WILL ADHERE TO THE SURFACE SO TREATED. Throw some clean water against it and observe the result! We have tested the same surface **MANY YEARS** after application and the same effect remains.

How to Use

BETEX is applied by means of a paint brush. All brickwork, stone, or cement, should be brushed perfectly clean with a wire or other stiff brush, and the liquid applied liberally, taking care to see that every spot is treated. **IT IS OF NO USE FOR WOOD.**

TAMAC PLASTIC FIRE CEMENT

For building or setting and repairing the fire-brick work of Fireplaces, Ranges, Stoves, Ovens, etc.

Withstands high temperatures without crumbling or contracting.

Ready for Use.

In tins from 1 lb. to kegs of 1 cwt.

PURIMACHOS FIRE CEMENT also stocked.



BAXENDALE & CO. LTD.



MILLER STREET · MANCHESTER

SEELASTIK

“Seelastik’s” unusual properties as a Sealing, Bedding and Caulking Compound have been known for years to the building trade.

“Seelastick” seals the joint between any two dry and clean surfaces—wood to brick, glass to metal, metal to brick, etc. It gives a lasting, flexible seal that is resistant to weather, heat, moisture, dust and is non-toxic.

HOW “SEELASTIK” IS APPLIED

“Seelastik” is not only an unusual compound, but it is packed and applied in an unusual manner—it comes to you packed in “Cellophane” cartridges which are loaded into the Expandite Hand or Air Pressure Guns, and the seal is applied just where it is needed. A quick, clean and economical method.

Two different size nozzles are supplied with each gun, but to meet the needs of the many various applications, a range of nozzles is available.

WHY “SEELASTIK” IS SPECIFIED

Mortar, cement and putty are three traditional materials with which joints are filled in building construction, but, because they set hard they should only be used for rigid or structural joints. There are a multitude of other joints—joints which move—in building construction, and it is essential that these joints are satisfactorily sealed against water seepage. A suitable compound to seal joints of this kind must possess a number of apparently incompatible, yet very essential properties:—

It must be soft enough to retain its elasticity, yet form a surface skin dry enough to take paint.

It must adhere tenaciously to many different surfaces, yet be easily applied.

It must stand extremes of temperature, neither going brittle in cold weather, nor slumping in hot.

It must not stain the most absorbent surface, nor discolour paint.

“Seelastick” possesses all these properties.

BAXENDALE & CO. LTD.

SECOMASTIC

A non-hardening, zinc coloured waterproof mastic for all joints in buildings where movement through variation of temperature is likely.

Applied from a cartridge by a special gun.

Also accepted in water.



WET WEATHER PAINTING

NEW zinc and asphaltic varnishes can be used provided with
GALVANOLITE Rapid
(wet surface grade)

The introduction of this new grade of GALVANOLITE which contains special ingredients enables its application to be carried out regardless of weather conditions. It can be applied even wet or during rainfalls and can be relied upon to give the extra lasting protection so often contained in the standard grade of GALVANOLITE.



MILLER STREET - MANCHESTER

TILUMA
FOR REFIXING TILES TO FIREPLACE SURROUNDS,
HEARTHES, CURBS, ETC.

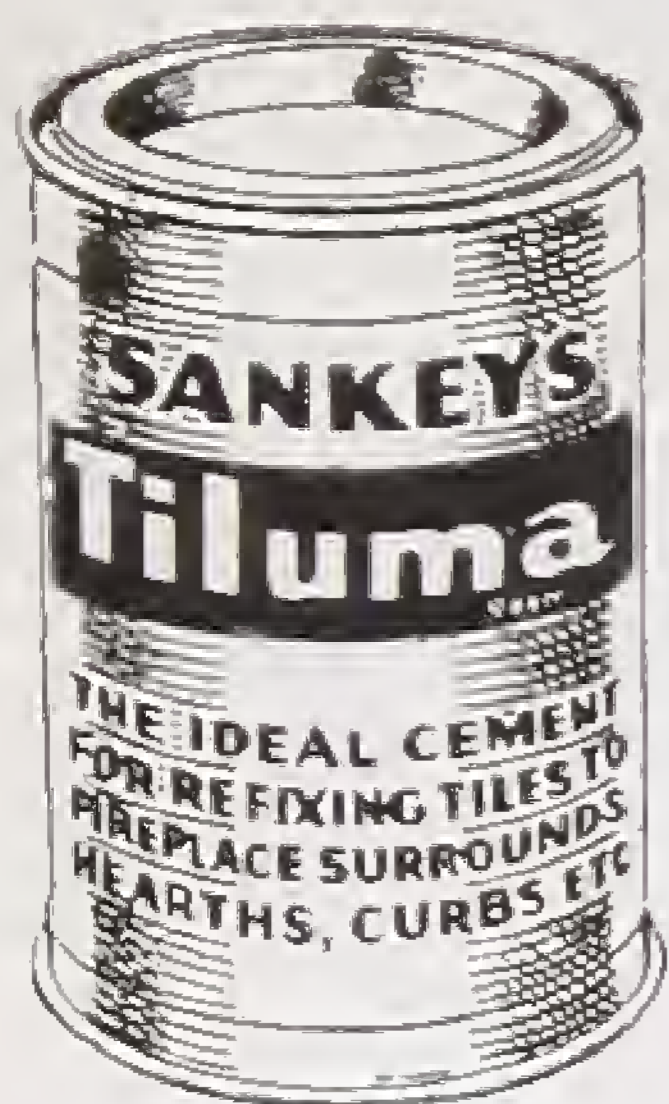

Stir the contents of tin well. Brush away all dirt and old loose cement from the tile and surface of the surround or hearth. Be sure that both surfaces are dry.

Spread Tiluma thinly and evenly on both the tile and its seating. Press firmly into position. Wipe off immediately and cleanly any excess cement at joints and any smears on the surfaces of the tiles. Broken tiles can similarly be refixed.

Always replace the lid on tin immediately, when Tiluma will remain unaffected and ready for future use. Store in a cool place.

"BOSS" WHITE
The Perfect Jointing Compound

For Acetylene,
 Benzol and
 Petrol Gas.
 For Superheated
 and Saturated
 Steam at
 All Pressures.

Contains no Lead.

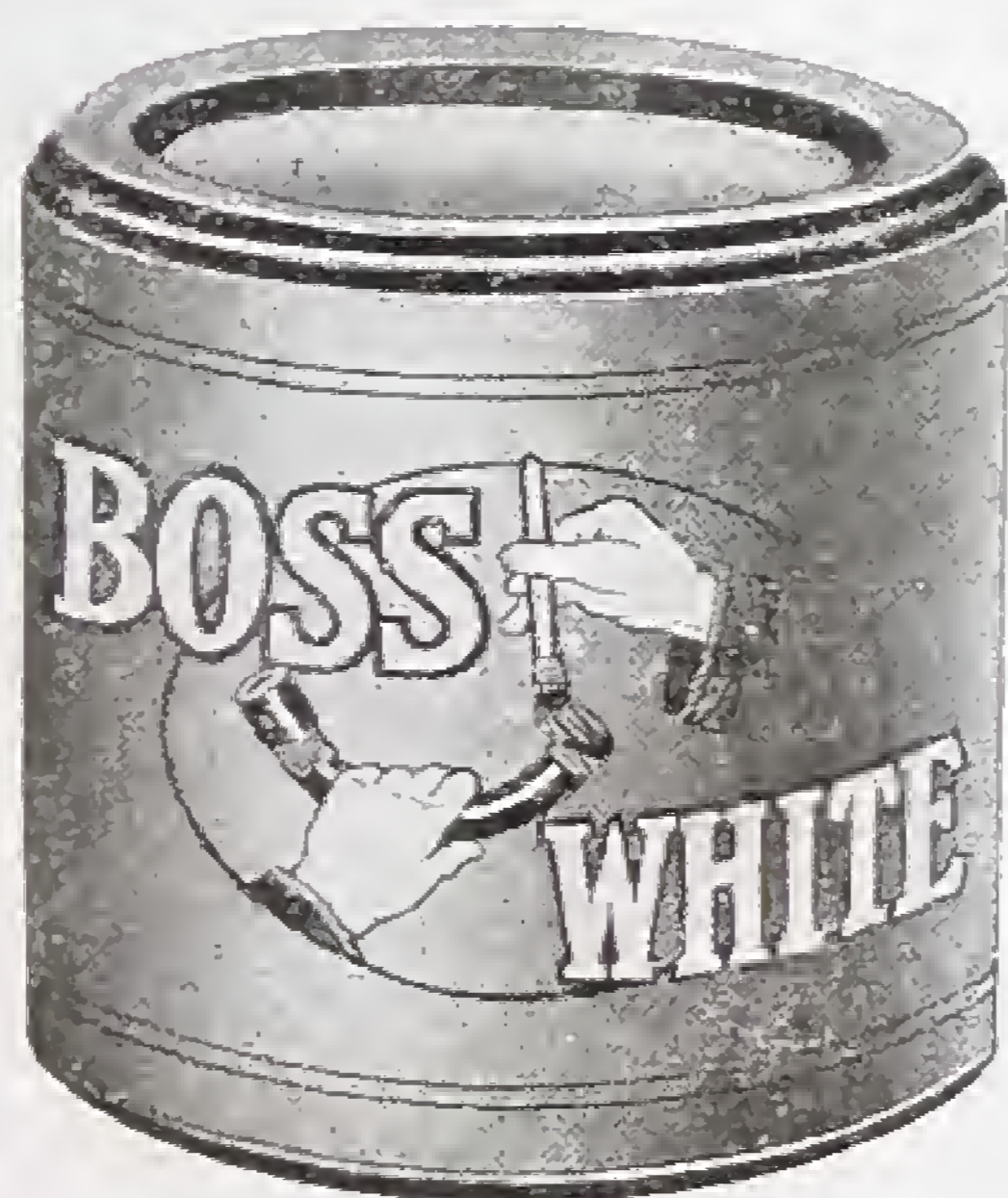

For Hot and
 Cold Water
 Piping.
 For Screwed
 Copper Piping
 and for All
 Purposes.

Non-poisonous.

"BOSS" White is particularly adapted to DOMESTIC HOT and COLD WATER requirements owing to its cleanliness. As its name implies it is a white compound and hence there is no dirty marking on the house decorations, etc. by the hands of the workman. It makes a strong lasting joint while its use facilitates the unscrewing at any time when required for additions and alterations. When copper pipe is used "BOSS" White is invaluable. The joints do not require cleaning down after making as is the case with black compound; this enables the workman to complete his work in less time.

PASTE POWDER



POLYCELL is a water soluble, soluble adhesive which can be used to glue the most porous fabrics used in book binding.

Polycell is used widely in gold leaf work for immediate use. It won't crack or stain or stain the surface. It is clear, odourless, kind on your hands and will not go mouldy or sour.

IT SIMPLY DOES NOT STAIN

Polycell is absolutely neutral—free of alkalies and acid, it will not discolor the most delicate paper, nor affect lacquer and gold leaf. Neither will it stain fingers, furniture or clothes.

IT WILL NOT SHOW AT THE JOINS

You can use Polycell freely at the edges of the paper. Any surplus can be lightly brushed away leaving you with a perfect, invisible join.

POLYFLIX is a famous cellulose product, easily mixed with water to form a thick, smooth paste. It can easily be brushed on any wall or ceiling surface with a common brush. When dry it forms a strong paper-like film, that protects, repels, and keeps stains away which will make any wallpaper look its best.



POLYLINA fills up small hair cracks in wood. It insulates small holes in masonry and makes an insulating barrier against water, noise, heat, dust from old paper and similar impurities harmful to new paper. When dry it results in further saving on finishing costs. It greatly reduces the cost of finishing and lining edges even with the most difficult wallpapers. According to the *Handbook of Application*, POLYLINA forms a thin plastic, it insulates in solution and brush and has the correct kind of insulating qualities for wood and iron.

Mixing paste by adding 1 lb. of water to 1 lb. of powder and the opposite. Before applying with the brush or trowel stir paste and keep warm. With a common brush or trowel brush, brush on evenly and gradually. A rough wall needs a thicker solution, smooth plaster and masonry a thinner and thinner solution.

PAPER-HANGERS' REQUISITES

No. P 536

FOLDING PASTE TABLE

Made from selected Whitewood. Will not warp. Folds up with space inside for tools.

Width, 22 in. open, 11 in. closed.

Length, 6 ft.

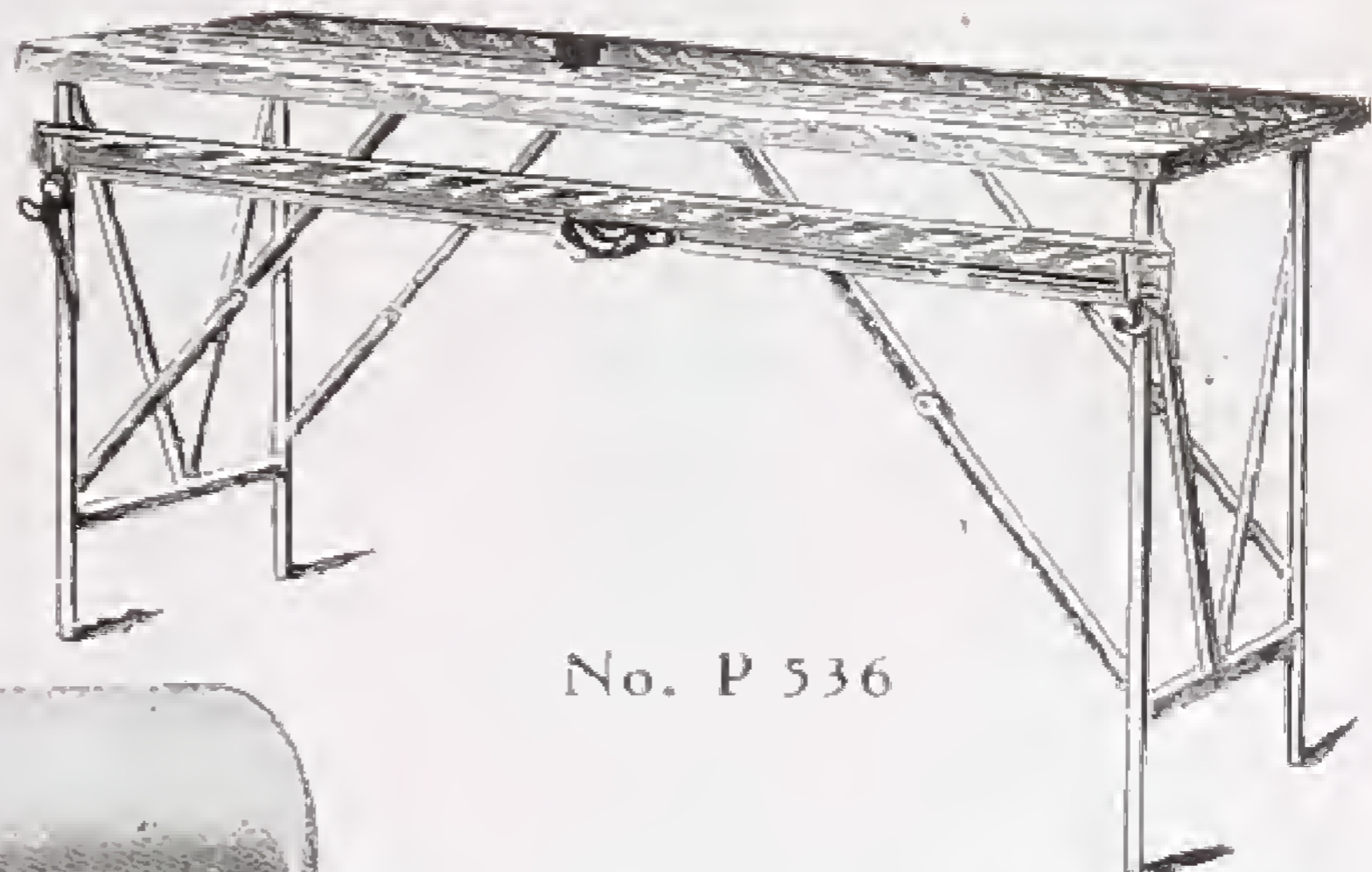

No. P 536

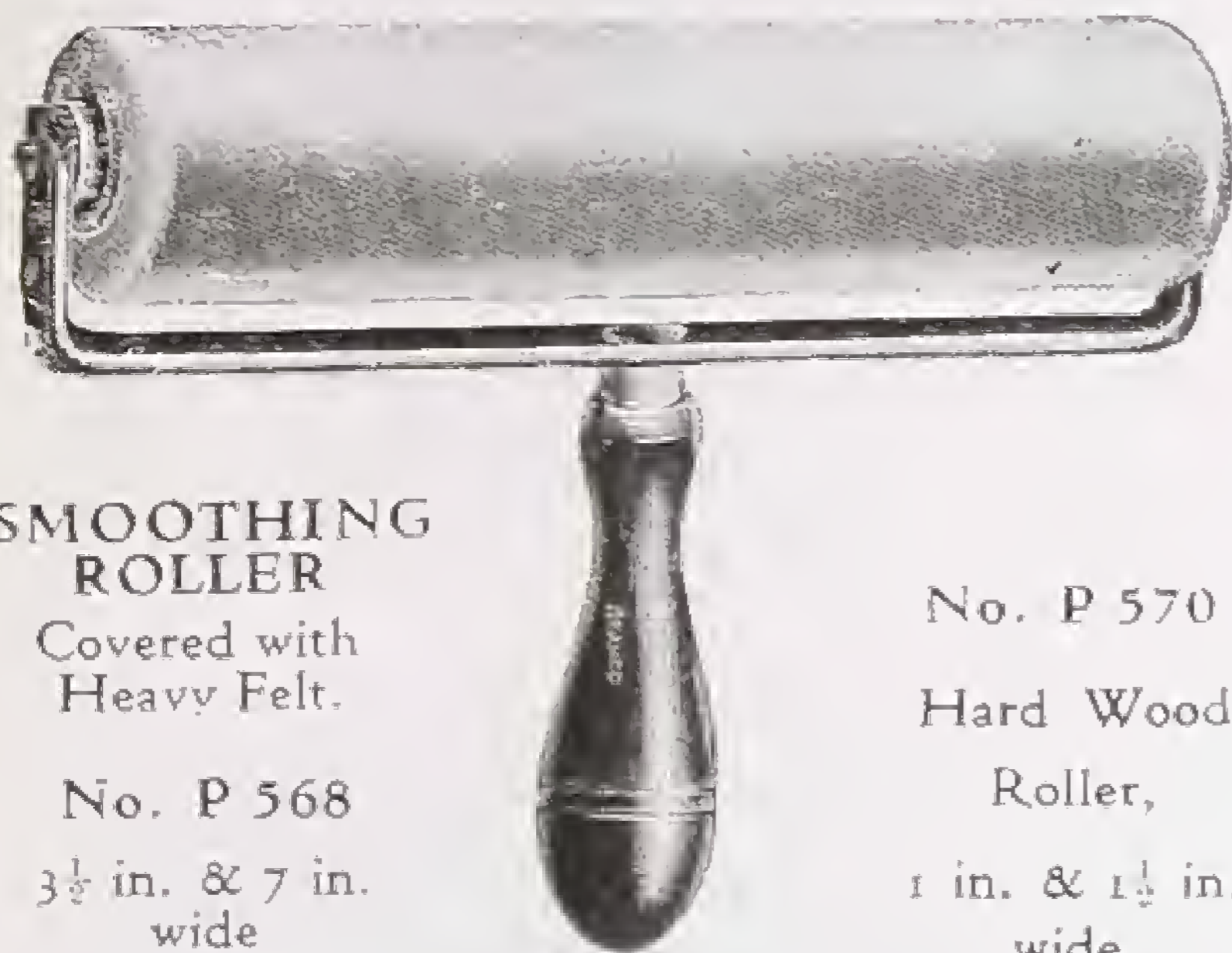

SMOOTHING ROLLER

Covered with Heavy Felt.

No. P 568

3½ in. & 7 in. wide

No. P 570

Hard Wood Roller,

1 in. & 1½ in. wide.

SEAM ROLLERS

No. P 556

2 in. wide, hard rubber.

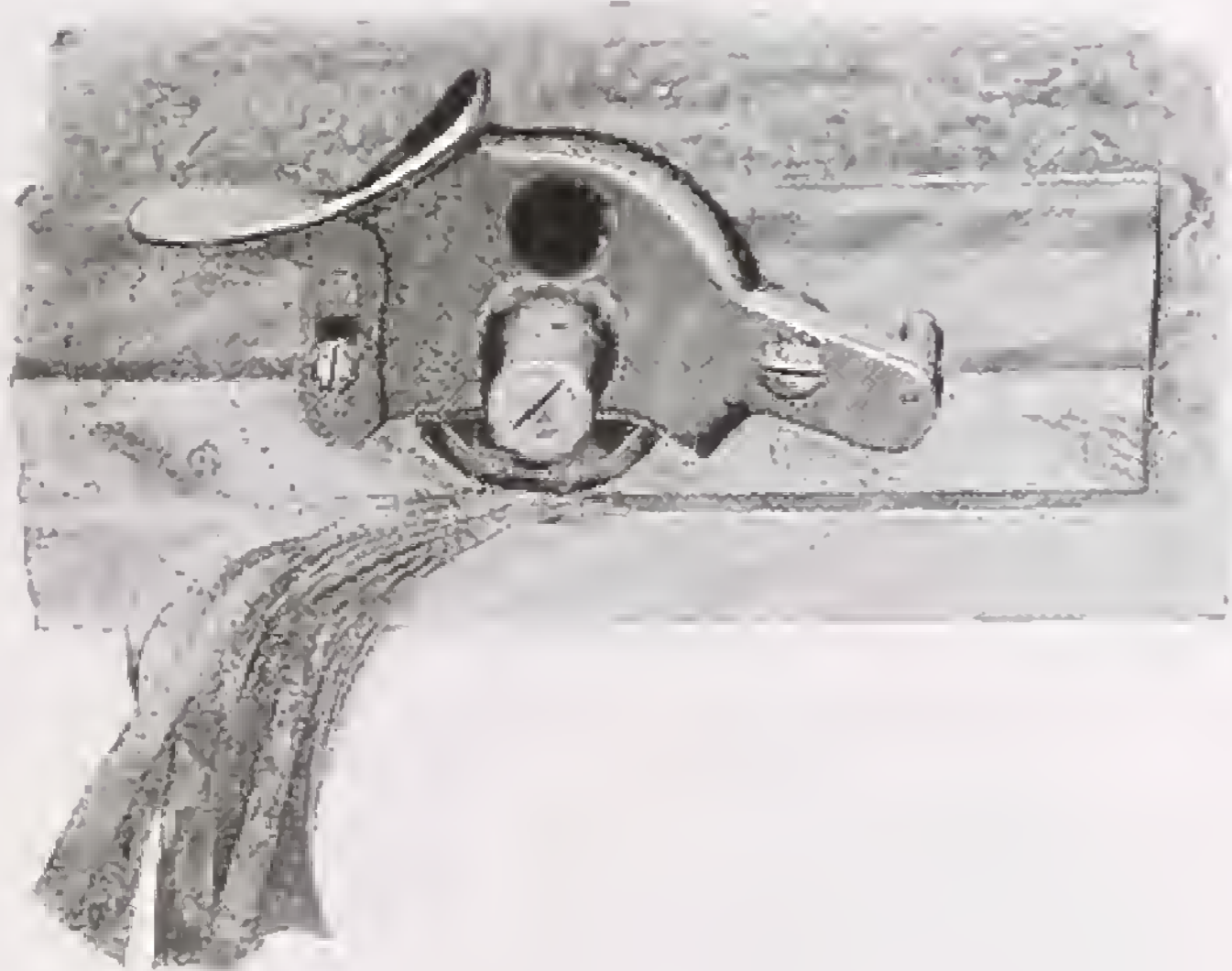

**No. WP 540
RIDGELY WALLPAPER TRIMMER**

Parts are interchangeable, and worn parts can be replaced.

Length of Straight Edge: 6 ft., 7 ft.

**No. IR 2837
PAPER-HANGERS' SCISSORS**

10 11 12 in.

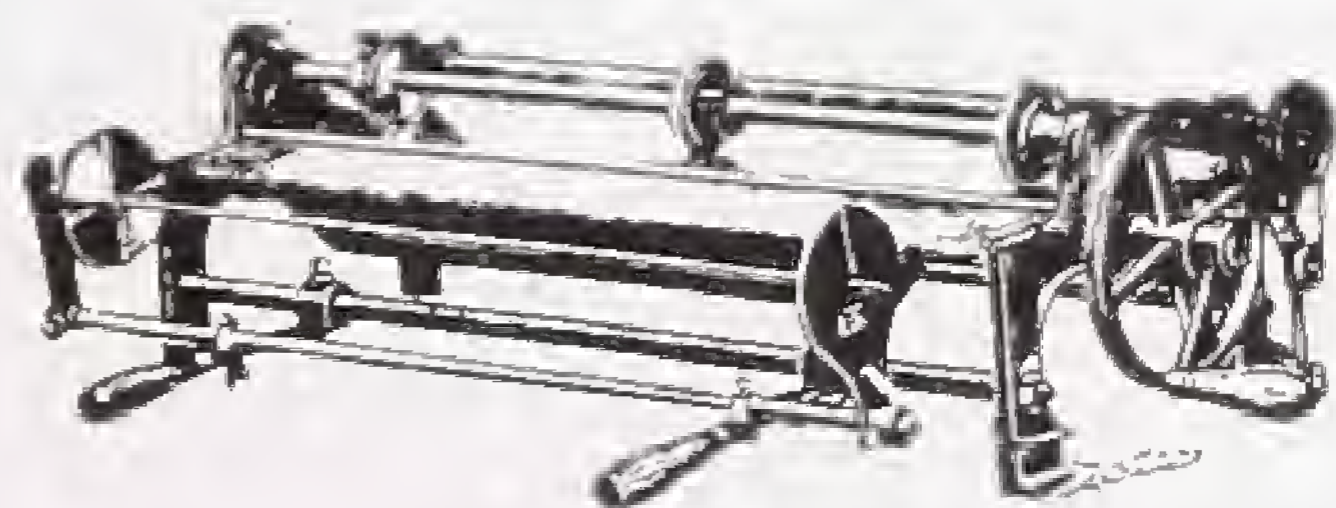

No. WP 541

THE EMPIRE TRIMMING MACHINE

For all widths of Wallpapers up to 22 in.

Pattern A. Unwinds, trims both edges, or one only, or one fine and one rough, and rewinds the roll at one operation in 40 seconds.

Pattern B. Carries all the improvements described for A and is made 8 in. wider. It will trim any width of paper from 18 in. (or narrower) up to 30 in.

BRUSHES



No. P 106



No. P 107



No. P 110



No. P 126



No. P 128

P 106. SASH TOOL Metal Head. Size Nos. 4 5 6 7 8 9 10 11
 P 107. SASH TOOL Metal Head. Size Nos. 4 5 6 7 8 9 10 11
 P 110. GEMINI BRUSH Case Edge. Copper Wire Head. Size Nos. 4 5 6 7 8 9 10 11
 P 126. FLAT VARNISH BRUSH Rubber Set Metal Head. Bevelled. Three-Piece Handle. Size Nos. 4 5 6 7 8 9 10 11 12 13 14 15 16 17 18 19 20
 P 128. FLAT VARNISH BRUSH Rubber Set Metal Head. Bevelled. Bevelled. Four-Piece Handle. Size Nos. 4 5 6 7 8 9 10 11 12 13 14 15 16 17 18 19 20



No. P 146
FLAT KAISHIME BRUSH
 Copper Head. Bevelled. Four-Piece Handle.
 Size Nos. 4 5 6 7 8 9 10 11 12 13 14 15 16 17 18 19 20



No. P 148
FLAT WALL BRUSH
 Copper Head. Bevelled. Four-Piece Handle.
 Size Nos. 4 5 6 7 8 9 10 11 12 13 14 15 16 17 18 19 20



No. P 154
ROUND NAILED TURK'S HEAD
 Leather Head. For White-work. Measure of one of head. Size of round work.



No. P 144
FLAT WALL BRUSH
 Fine Elm Handle. Leather Head. Laminated Tapered. Size Nos. 4 5 6 7 8 9 10 11 12 13 14 15 16 17 18 19 20

BRUSHES



No. P 411. FITCH

In Tin, Polished Handle. Hog Hair.
Flat or Round.

P 411	Sizes	4	6	8	10
P 413	Sizes	$\frac{1}{4}$	$\frac{1}{2}$	$\frac{3}{4}$	in. wide

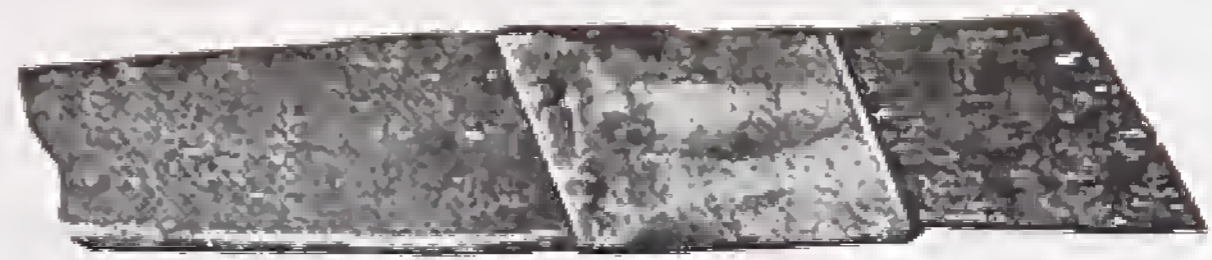

No. P 413. LINING FITCH

Wood Handle. Hog Hair.



No. P 377

STENCILLING BRUSH

Metal Bound. Stiff Black Bristles.

Sizes 8 10 12 14 16



No. P 381

GLUE BRUSH

Metal Bound with Wire Bridle.

Sizes 8 10 12 14 16 18



No. P 374

PAPER-HANGING BRUSH

Pure Bristle. Size 9 in.



No. P 379. JAMB DUSTER

with Whitewood Handle

Size 4 in.

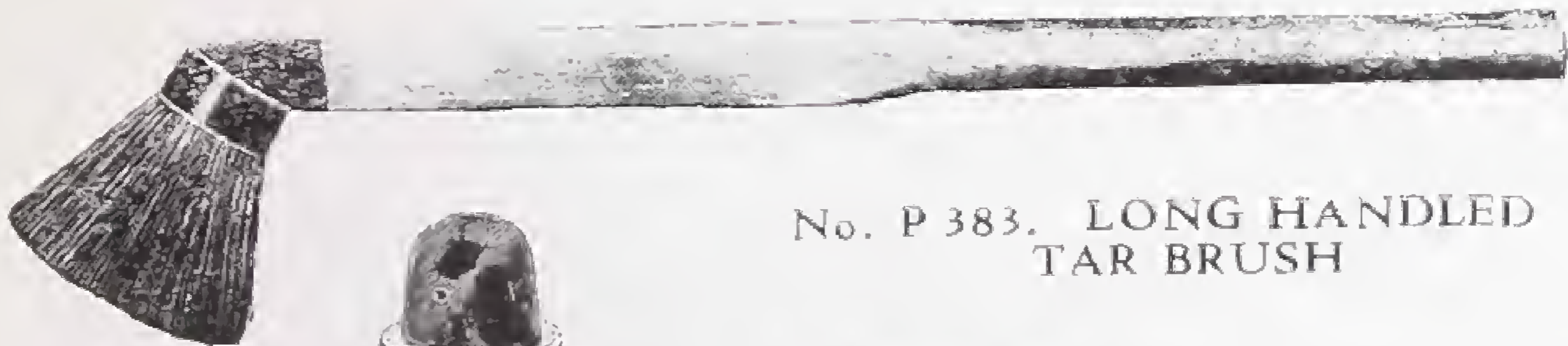

No. P 383. LONG HANDLED
TAR BRUSH



No. P 385

TURK'S HEAD TAR BRUSH



No. P 387. SHORT HANDLED
TAR BRUSH



No. P 407

GILDER'S MOP

Wood Handle. Camel Hair
Sizes Nos. 4 to 10.

SPONTEX SPONGES



"Spontex" sponges don't clog—they absorb and discharge liquids freely and copiously.

"Spontex" sponges are not affected by mild acids and alkalis providing they are rinsed and squeezed out after use.

SPONTEX

This name is your guarantee that you have top quality, and the best and most economical DECORATORS' SPONGE.

VARNISH or PAINT BRUSH
Pure Bristle
Shaped Handle. 1/2 in. to 4 in.

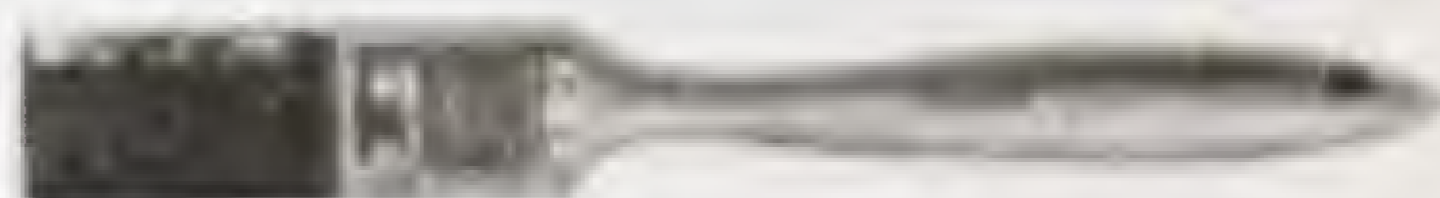

"LOTI" BEST QUALITY GLOSS PAINT BRUSH

Thicker than above.



Pure Bristle.
1 in. to 4 in.



CREVICE or
RADIATOR
BRUSH

1/2 in. wide
(pure bristle)



Illustrating the many types and makes of good quality Paint Brushes available from our stock.

PAINTERS' AND GLAZIERS' TOOLS

No. P 492
PUTTY KNIFE BRASS BOLSTER
 1, 1½, 2 inch wide blade



No. P 496
PAINT SCRAPER
 Riveted Handle.
 Blade 2½, 3, 4 in. wide

No. P 500
PUTTY KNIFE
 Clipt Point. Flexible
 Ebony Handle.



Blade 1½ in. wide

No. M 202
HACKING KNIFE
 Strong. 4½ in. Blade.
 Best Quality. Three Rivets.

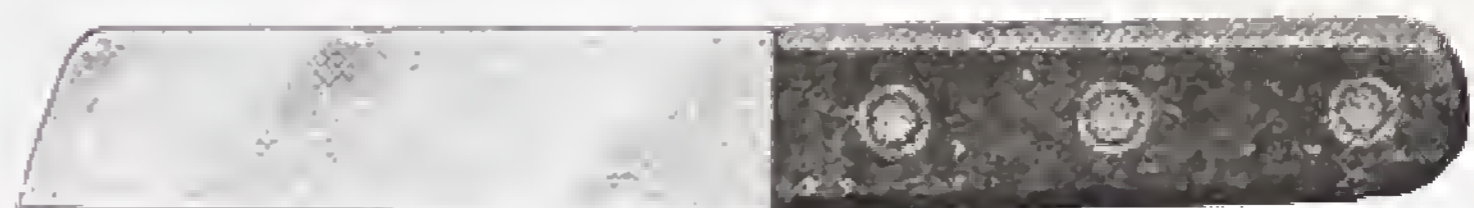

GRAINING COMBS

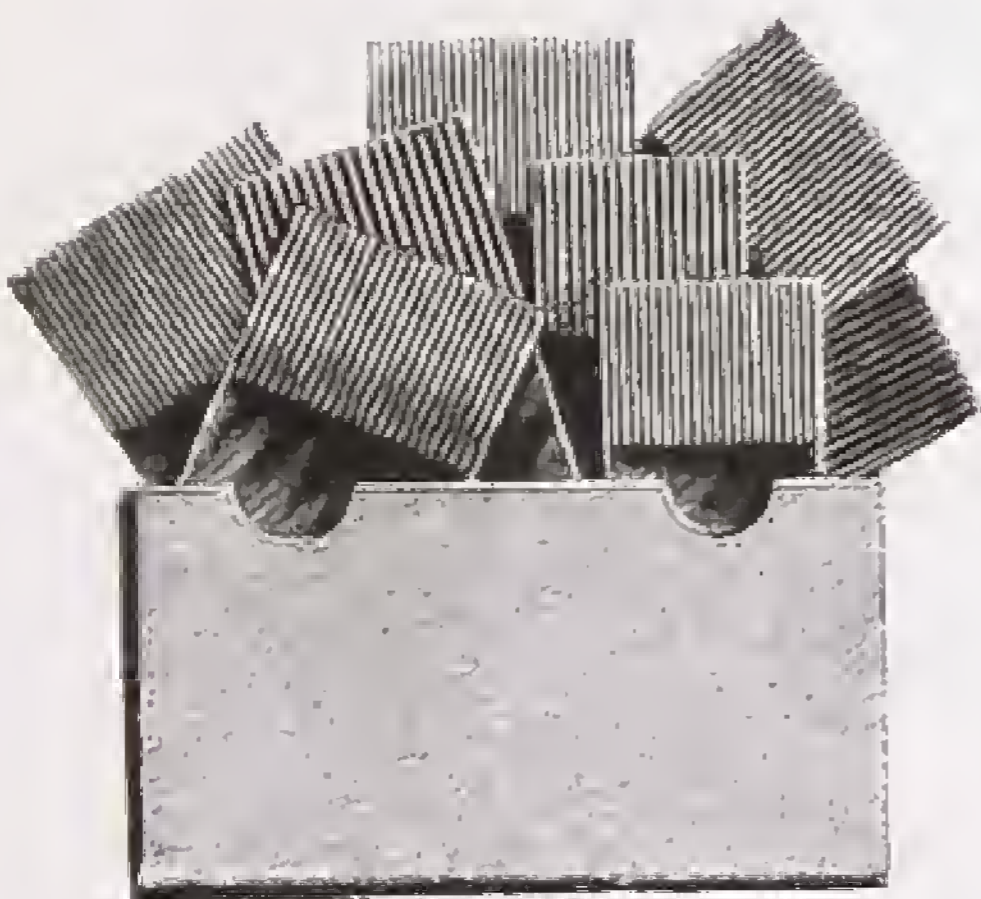

No. P 450
STEEL GRAINING COMBS
 30 assorted in Tin Case.
 Coarse, Medium, Fine or Graduated.

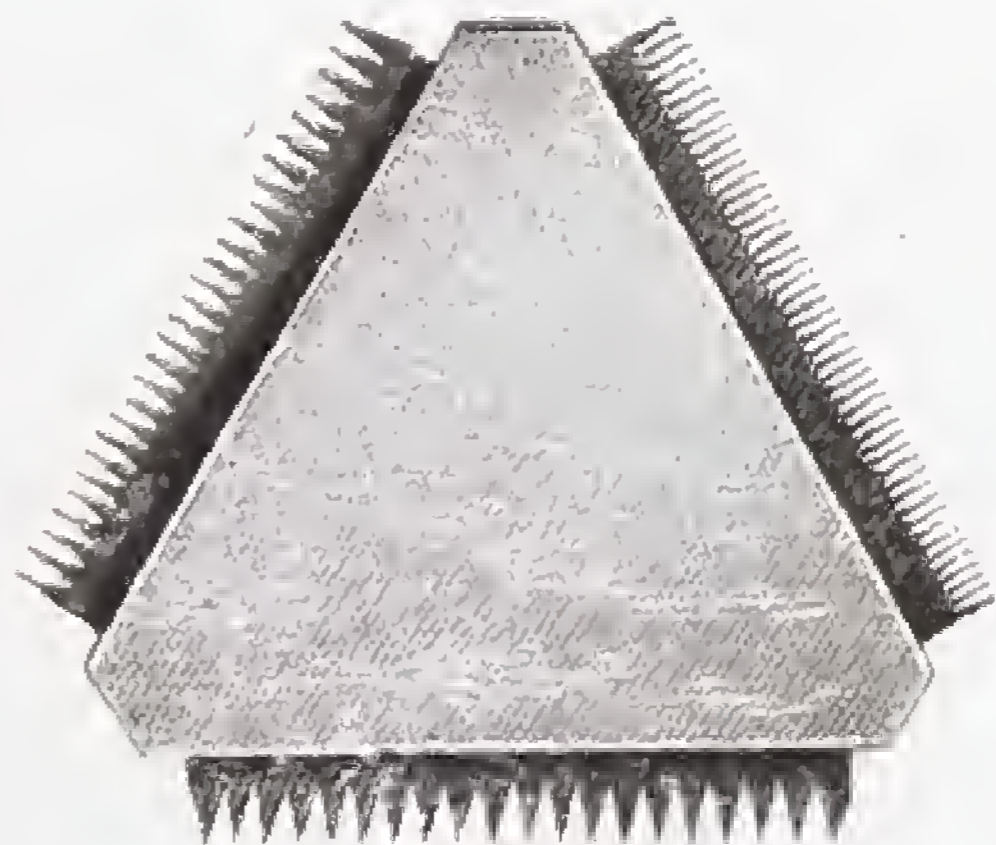

No. P 441
FLEXIBLE GRAINING COMB
 (India-rubber.) Triangular Shape
 Fine, Medium and Coarse Teeth
 All one Tool.

BAXENDALE & CO. LTD.

GLAZIERS' DIAMONDS, ETC.



No. GL 221

ORDINARY SHEET GLASS DIAMOND

Qualities	—	A ₁	A ₂	A ₃	A ₄
Qualities	—	B ₁	B ₂	B ₃	B ₄

Tools
are shown on
pages 366-386

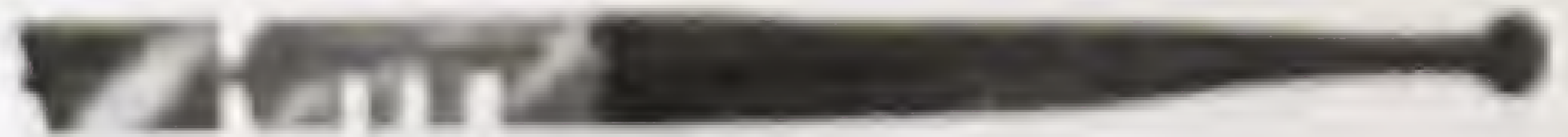

No. GL 222

GLAZIERS' DIAMOND WITH RACK

A compact Glazier's Diamond with the advantage of a Rack combined.

Qualities	—	A ₁	A ₂	B ₁	B ₂
-----------	---	----------------	----------------	----------------	----------------

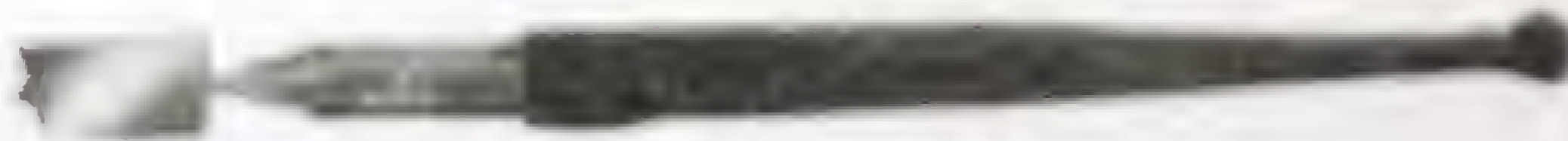

No. GL 223

POLISHED PLATE GLASS DIAMOND

Qualities	—	A ₁	A ₂	B ₁	B ₂
-----------	---	----------------	----------------	----------------	----------------



No. GL 224
SURE CUT

The wheel keeps the Diamond sharp on the cut. Made to all Grades of Ordinary Diamonds.



No. M 1411
GLASS CUTTER
Best Quality
One Wheel,
also single wheel

No. M 1413A
(U.S.A. Made)
One Wheel.



No. M 1226
PLATE GLASS PLIERS

Size — 7 in.



No. GL 227
GLAZIERS' CUTTING
LATHS, AND T SQUARES

Best Quality — Best Tipped
Divided into Inches and Eighths

No. GL 218
GLASS
CIRCLE
CUTTER



LOY FOR 1001 REPAIR JOBS

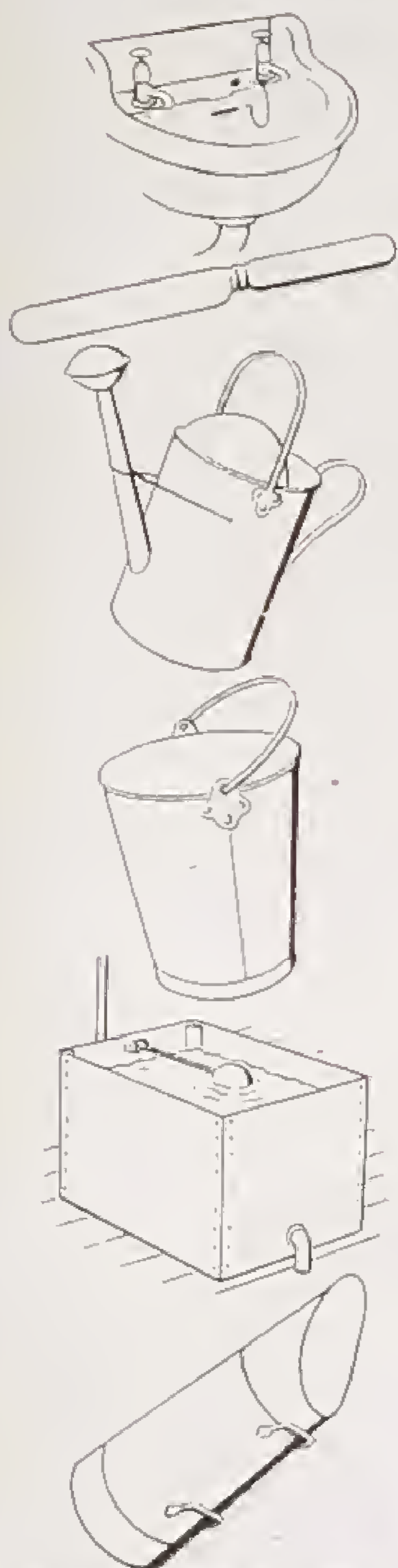

Mends holes, dents and leaks in metals

Adheres permanently—will not shrink, chip or peel.

Completely hygienic—will not affect food.

Withstands boiling water—is petrol and oil proof.

Can be filed, drilled or sawn.

Equally effective on wood, glass, canvas, plastic, etc.

Will outlast the part repaired.

Apply Loy Metal like putty—fills dents, holes, etc. Sets metal hard. Can be filed or sanded. Takes paint or cellulose.

LOY SHEETING.

For bridging gaps. Re-inforces weak rusted metals before applying Loy Metal. Self-adhesive.

LOY SOLVENT

Thins Loy Metal and also softens Loy Sheeting before applying. Cleans surface to be repaired.

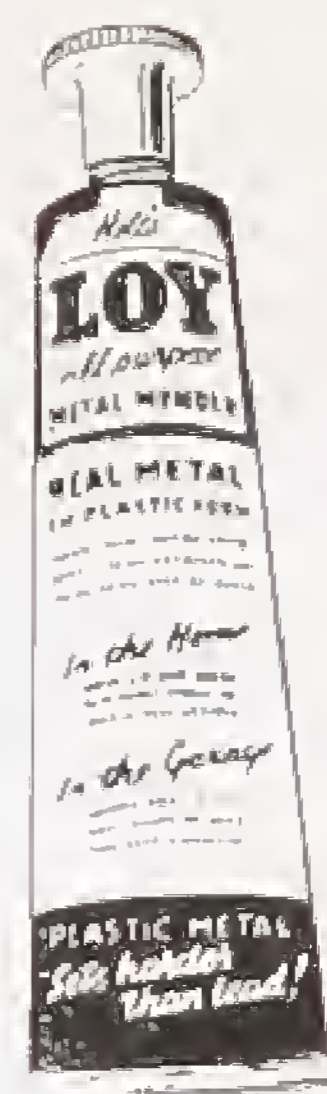

Holt's Domestic **HOLTWELD**

A permanent repair for leaks and cracks in radiators, tanks, boilers, pipes, etc.

A 60 minute repair—just pour it in. Does not clog water—only cracks are affected. Withstands high temperatures and water pressures. No dismantling.

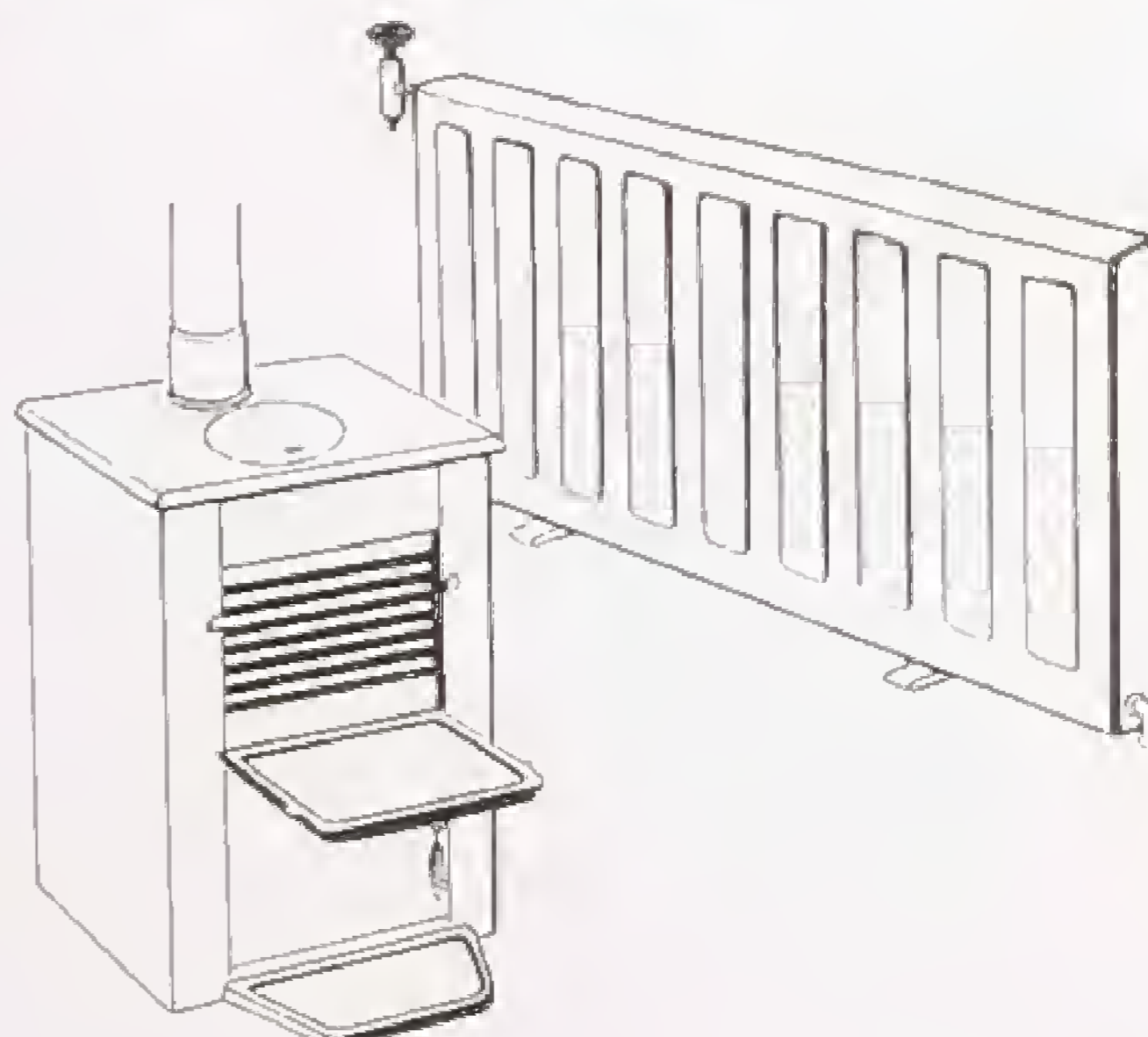

**THE SMALLEST GENUINE "MAX SIEVERT" SWEDISH
BLOW-LAMPS FOR USE WITH PETROL**

$\frac{1}{2}$ pint



No. P 881

$\frac{1}{2}$ pint



No. P 882

For the tradesman—plumber, electrician, painter, builder, etc., there is nothing to compare with the standard $\frac{3}{4}$ pint capacity (petrol) lamp or the 1 pint size fitted with powerful pump in handle.



No. P 875

*Other Types
of blow-lamps,
of British
manufacture,
also
available
from stock*



No. P 876



No. P 155

For those who prefer a petrol lamp with an inclined burner, the original one shown fulfils this need. Holding $\frac{3}{4}$ pint petrol it is a convenient size and weight for most jobs.

Complete list sent on application

**THE GENUINE ORIGINAL "MAX SIEVERT" SWEDISH
BLOW LAMPS (PARAFFIN)**

Possesses a number of improvements not to be found in any other Petroleum Blow Lamp. The Burner is of a non-carbonising type and has double the life, and the Brass Air Pump, of an improved design forms part of the handle, and works perpendicularly.

	Nos.	P 885	P 886
Capacity	...	1	$\frac{1}{2}$ pint



No. P 885

For works use in brazing. Stands really hard wear. Powerful flame of 9 in. to 12 in. according to size of lamp.

Capacity from $1\frac{1}{2}$ pints to 7 pints of paraffin.

No. P 891

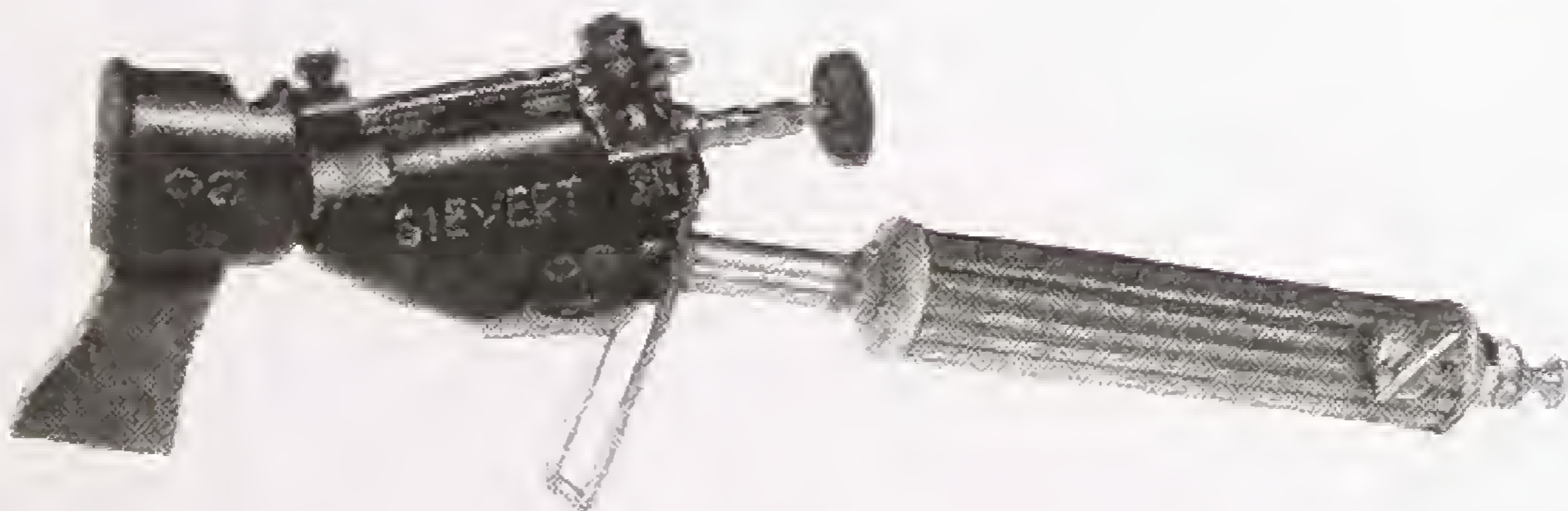
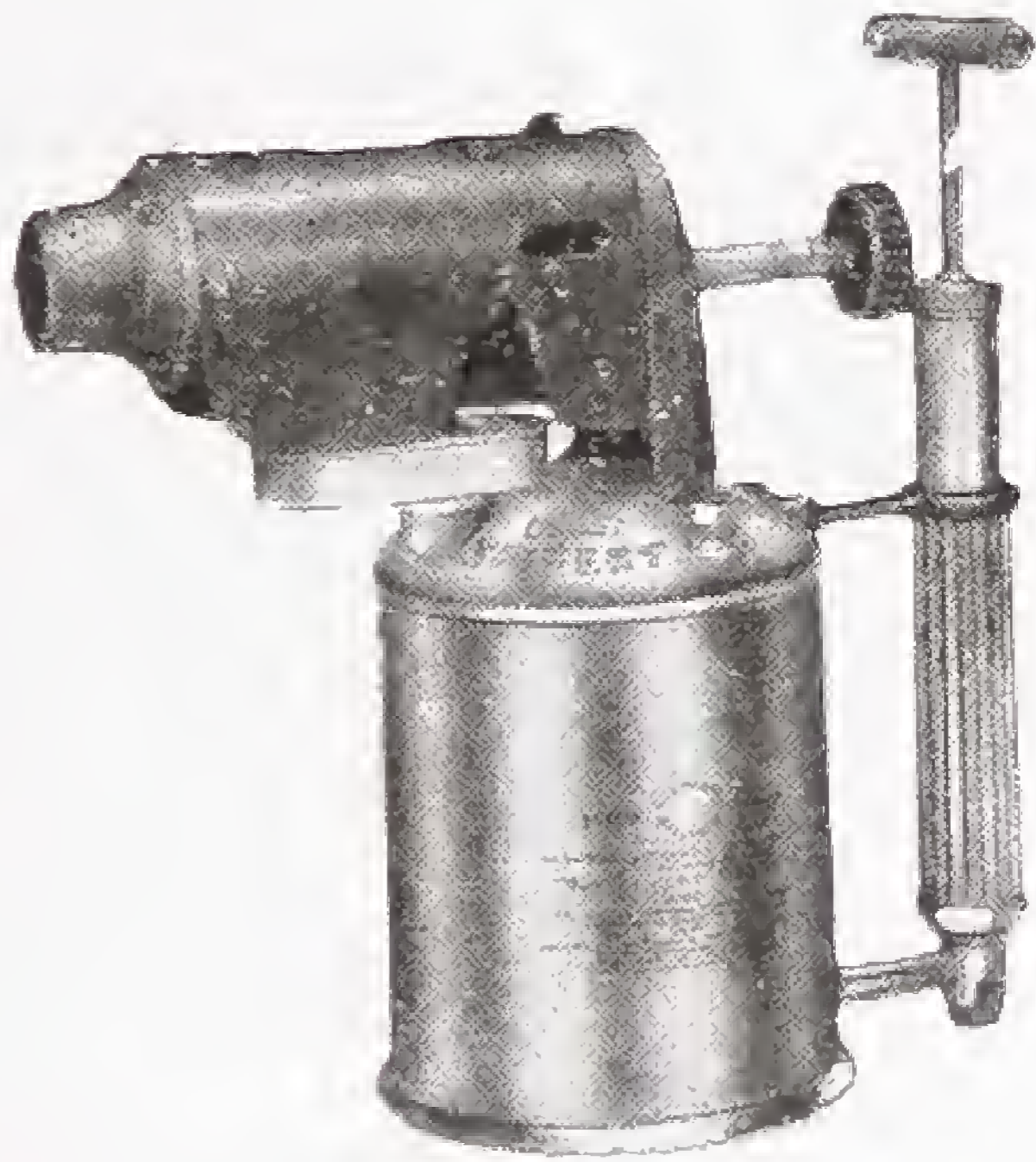

No. P 905

SOLDERING BUTTS (FOR PETROL)

Still used largely for roof work or where it is impossible or undesirable to use an Electric butt.

FURNACE PANS



RUSTLESS FURNACE PANS

No. R 100

8	10	12	14	16	18 Gallons
20	25	30	35	40	45 ..

Larger Sizes also supplied.

BUILDERS' AND CONTRACTORS' PLANT

of every description quoted for on application.

STREET FIRE GRATES AND BASKETS



STREET FIRE GRATE

No. H 1000

STREET FIRE GRATE

No. H 1001

(With Bridge and Pin Hook)
12, 13, 15, 18 and 21 in. dia.

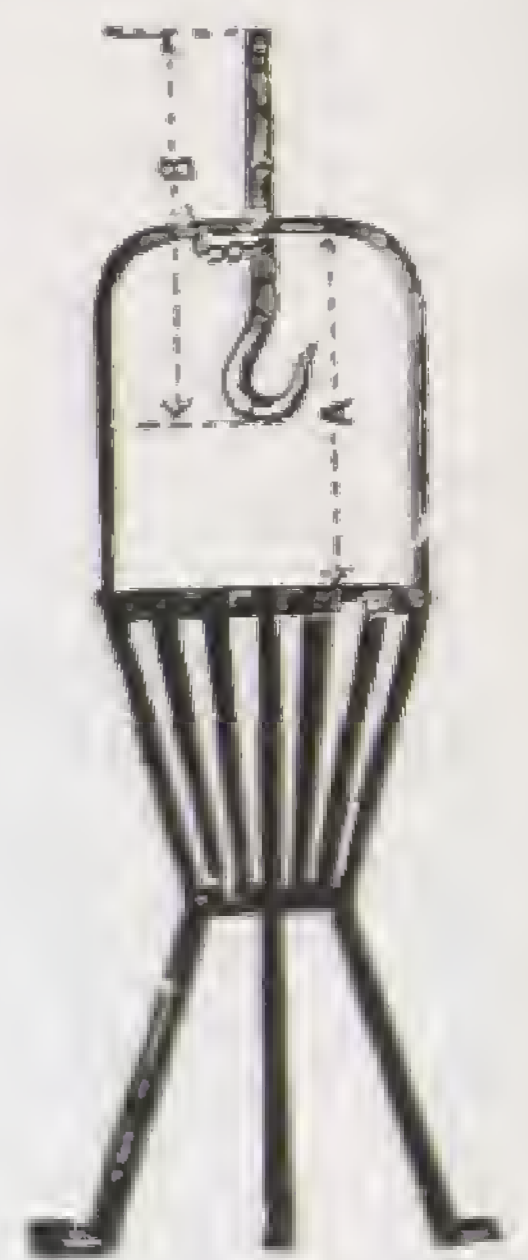

FIRE BASKET

No. H 1003

(With Bridge and Pin Hook)

$\frac{1}{2}$ in. Plate.

STREET FIRE BASKET

No. H 1004

(With Bridge and Screw Hook)

$\frac{1}{2}$ in. Plate.

12, 14, 16, 18 and 20 in. dia.

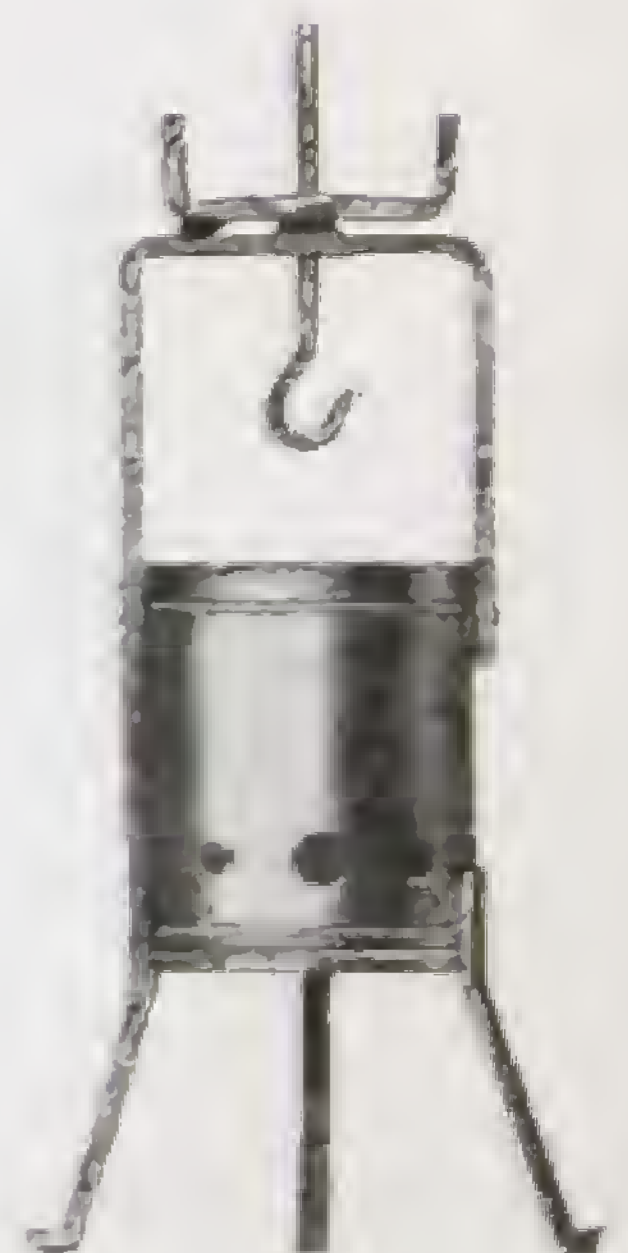
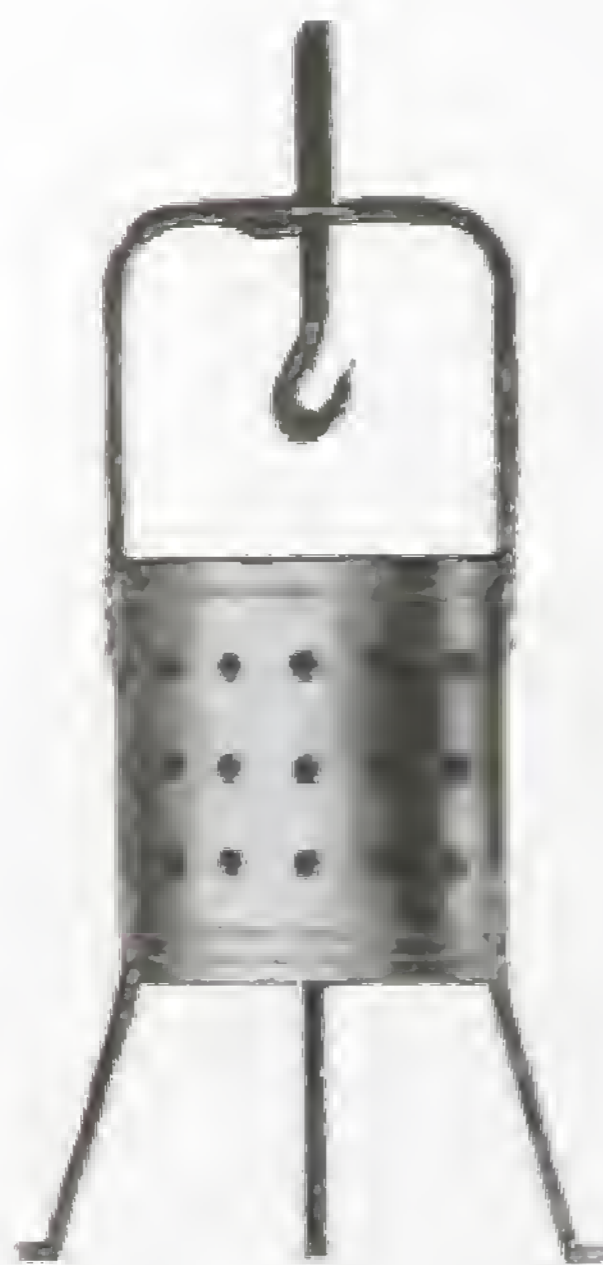

DRAIN RODS, FITTINGS, ETC.



In Sets 30, 39, 51, 60, 69, 81, 90, 99, 111, 120 feet

DRAIN CLEANING APPARATUS

No. B 1950

Rattan canes, 3-ft. long fitted with brass screws, double worm screw, brass clearing wheel, 4-in. rubber plunger, drop scraper and straps.

No. B 1943 DRAIN CLEANING APPARATUS

As above but canes and fittings supplied with Ideal lockfast joints.
In Sets 30, 39, 51, 60, 69, 81, 90, 99, 111, 120 feet

CHIMNEY SWEEPING APPARATUS

No. B 1944

Rattan canes 3-ft. long, fitted with brass screws and 18-in. dia. 4-row bass head and straps.

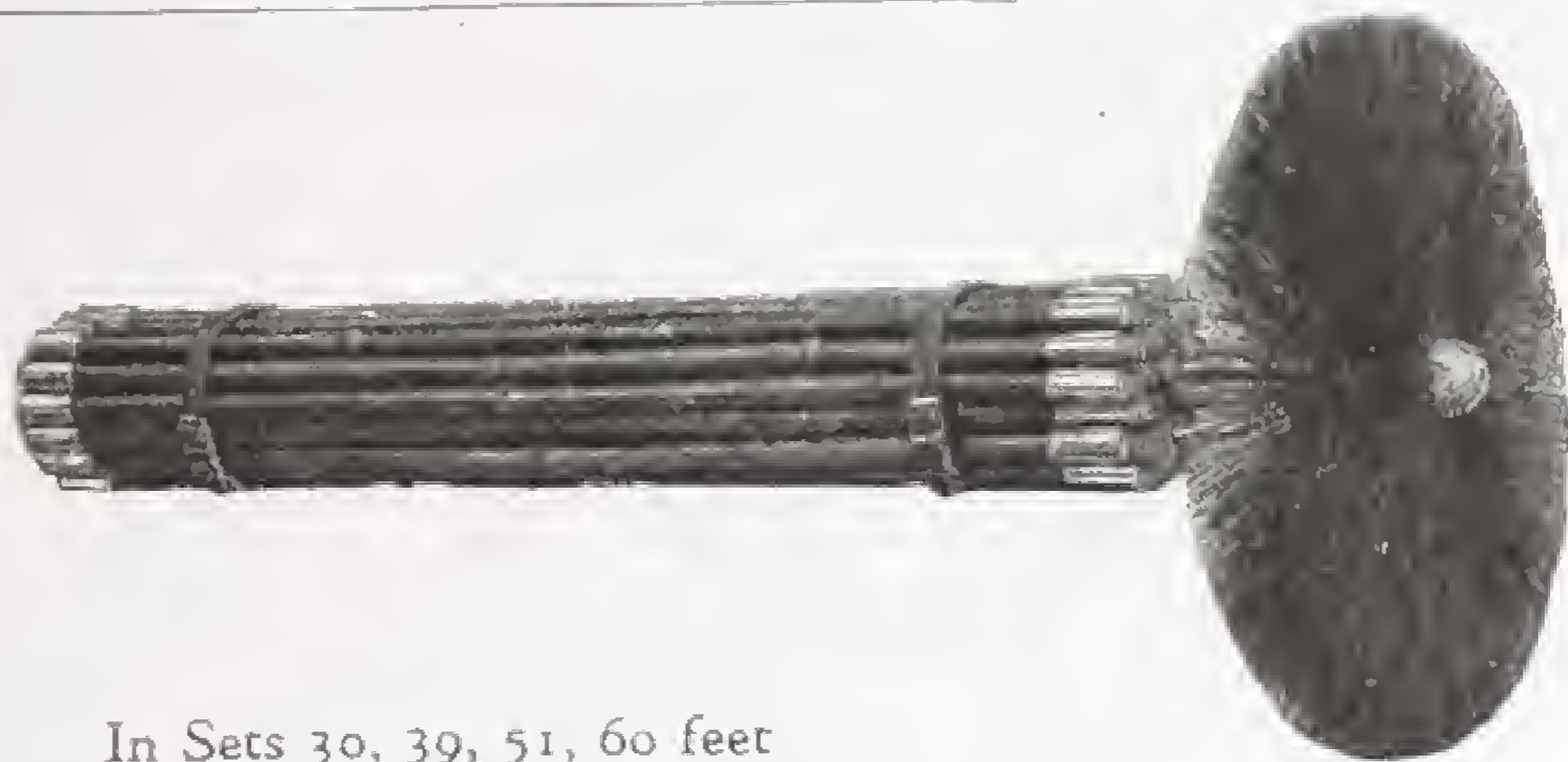

In Sets 30, 39, 51, 60 feet

Drain Rods can also be supplied separately.



No. B 1953



No. B 1954



No. B 1955



No. B 1952



No. B 1957



No. B 1958



No. B 1960



No. B 1956

FITTINGS FOR DRAIN CLEANING APPARATUS

- B 1952. Double worm screw.
- B 1953. Rubber plunger, 4 in.
6 in.
- B 1954. Brass clearing wheel.
- B 1955. Drop scraper, 4 in.
- B 1956. Spring hook.
- B 1957. Revolving roller.

- B 1958. Bass drain brush.
4 in. diam.
6 in. "
7 to 9 in. diam.
- Sweeps' brush (as illustration) B 1944
18 in. diam., 4 row.
- B 1960. Gun metal wheel.

DRAIN CLEANING APPARATUS

No. B 6293

**WASTE WATER PIPE
CLEANSER**

For Bathroom and Kitchen, etc.,
 $\frac{1}{2}$ in. diameter.

6 9 12 feet



No. B 6291

**DRAIN CLEANING WIRE
OUTFITS**



Made from good Spring Steel very strong and durable yet easy to operate. Will go round very acute bends in pipes, etc., and quickly opens up choked drains.

With 6 ft. \times $\frac{11}{16}$ in. Spring and 3 in. Brush.

4 in. Brushes extra.

Extra lengths of Spring extra.

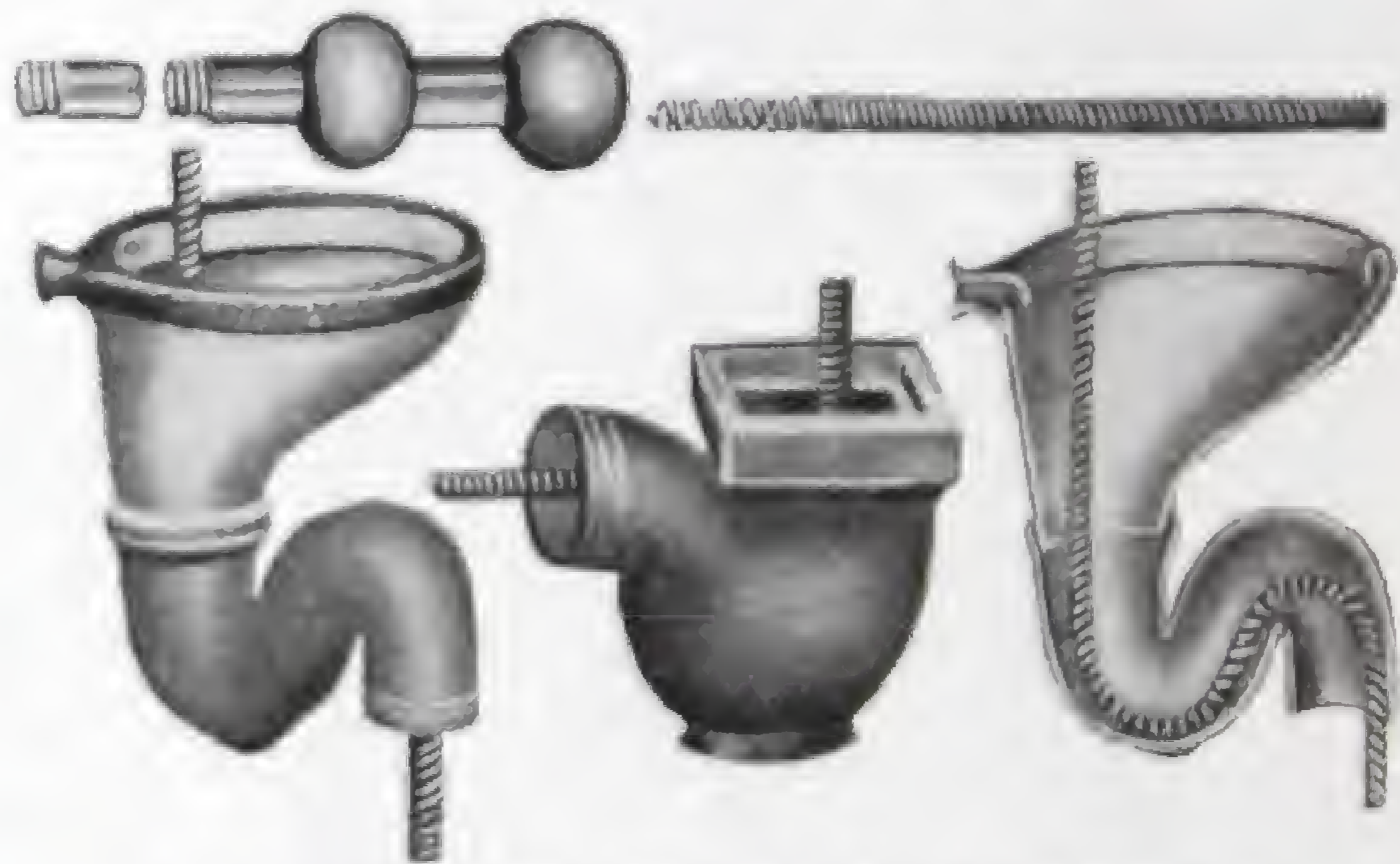

No. B, 6292. THE FERRET DRAIN CLEANER

Rods are made of steel wire with Lock-fast flexible Joints which cannot break, or become loose in the drain.
A Siphon can be cleared through the air inlet, by attaching the Ferret to ordinary cane rods, or by a special joint provided for the purpose.
The handle is attachable to the Ferret by means of a screw to enable the user to twist the rods, at the same time applying pressure.
Sets 6 ft. long in two lengths, with handle and joints.

DRAIN STOPPERS, PLUNGERS, ETC.

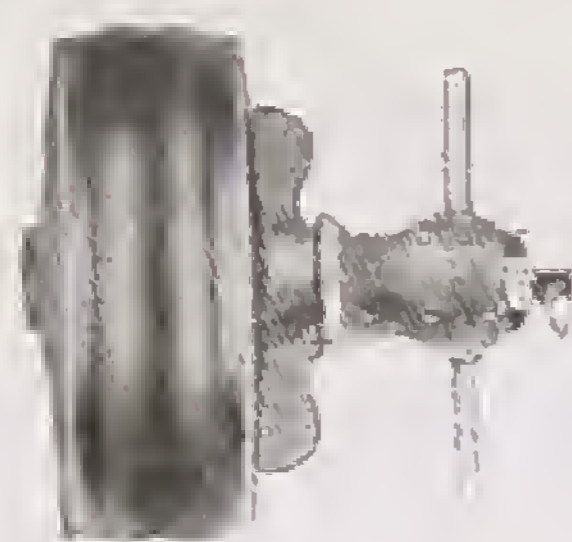

No. B 1961
EXPANDING DRAIN
STOPPER WITH $\frac{1}{2}$ -in.
CENTRE OUTLET

This stopper consists of two plates of metal between which a special rubber ring is fixed by means of grooves in the plates. It is screwed up by handle or key which causes the rubber to extend sufficiently to plug any pipe according to the size of the stopper used.

Standard sizes : 4 in., 6 in., 9 in., 12 in. dia.

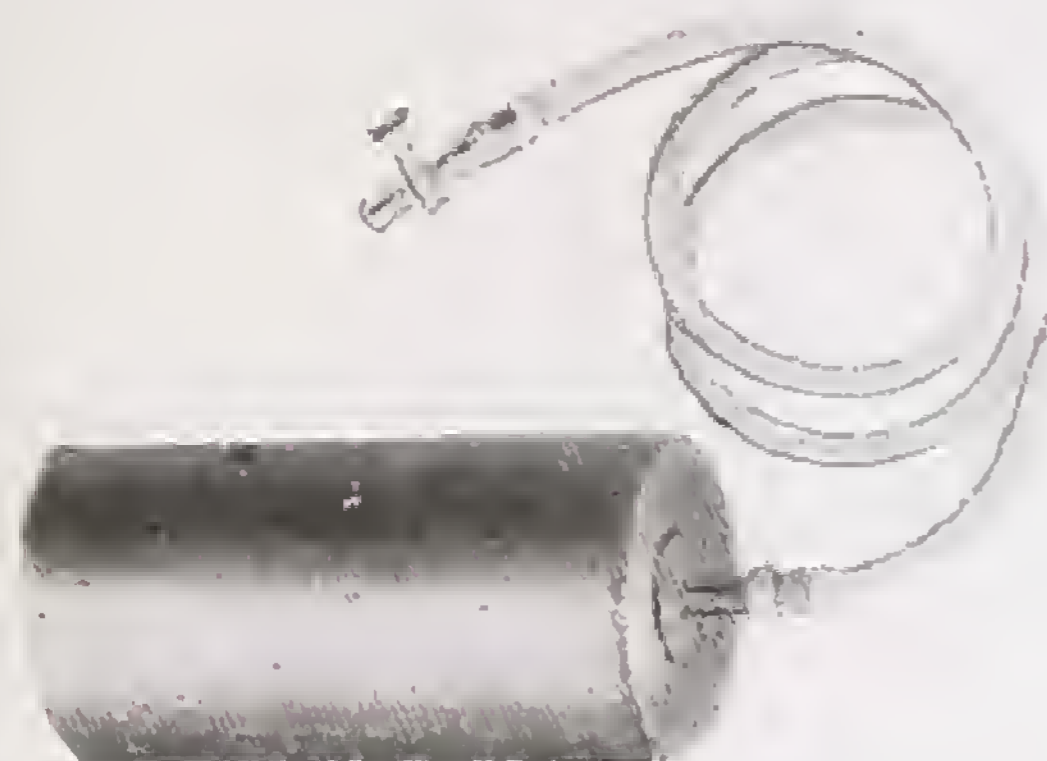

No. B 1965
CYLINDRICAL AIR BAG
STOPPER

Standard Size with 4 ft. 6 in. length of rubber tube and heavy brass cock screwed $\frac{1}{4}$ in. gas.

Sizes 4 in., 5 in., 6 in., 9 in., 12 in. dia.

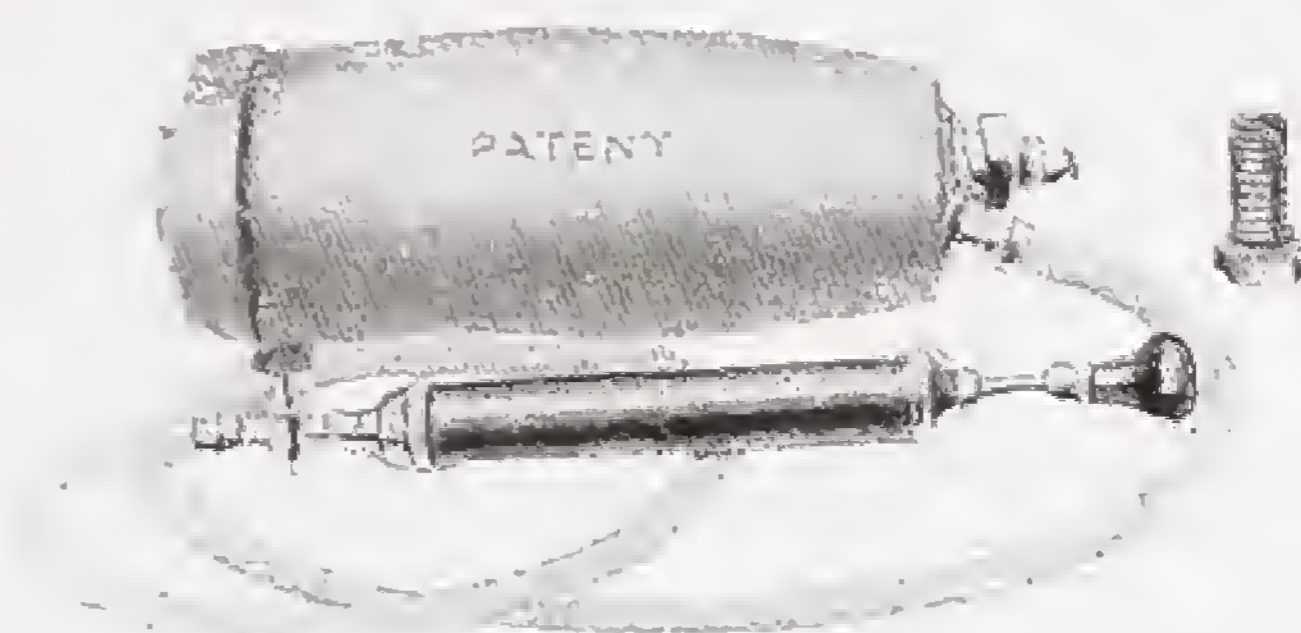

No. B 1963
FLEXIBLE BAG PIPE
STOPPER

With 1 in. bore wired rubber tube through centre and union for connecting to drain testing machine.

Complete with 4 ft. 6 in. air tube and cock.

Standard sizes 4 in. and 6 in. dia. only.

The illustration also shows a pump for inflating bag stoppers of very heavy construction, easy to operate.



No. B 1971
COOPER'S PLUNGER
Size, $5\frac{1}{2}$ in. diam.

With 24 in. fixed wooden handle ; for 4 in. drains, sinks, lavatories, or baths.



No. B 1967
INDIA-RUBBER FORCE CUPS
Small 3-in. cup, $5\frac{3}{4}$ -in. long overall
Medium $4\frac{1}{4}$ -in. cup, $12\frac{1}{2}$ -in. long overall
Large $5\frac{5}{8}$ -in. cup, 20-in. long overall

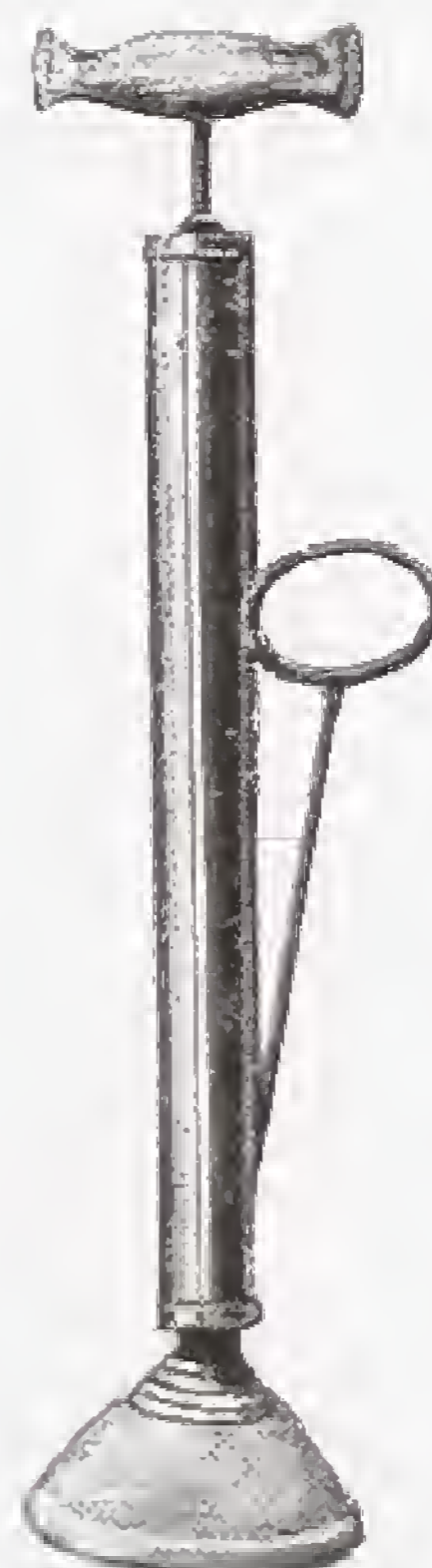

No. B 1972
THE TYPHOON
FORCE PUMP

TOOLS

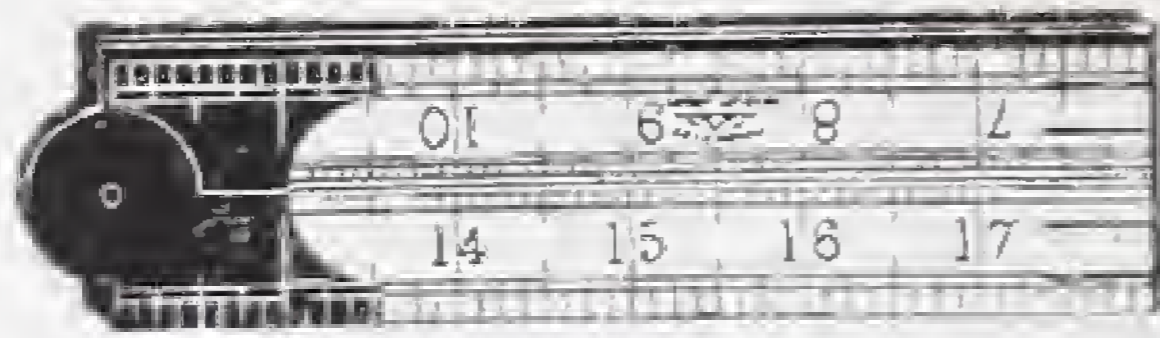

No. M 1435
2-Ft. FOUR-FOLD BOXWOOD
RULE, ARCH JOINT

1½ in. wide, marked in inches,
8ths, 16ths, 10ths, and 12ths.

No. M 1436 3 ft., as above

No. M 1433

Similar but 1 in. wide. 2 ft., 3 ft.

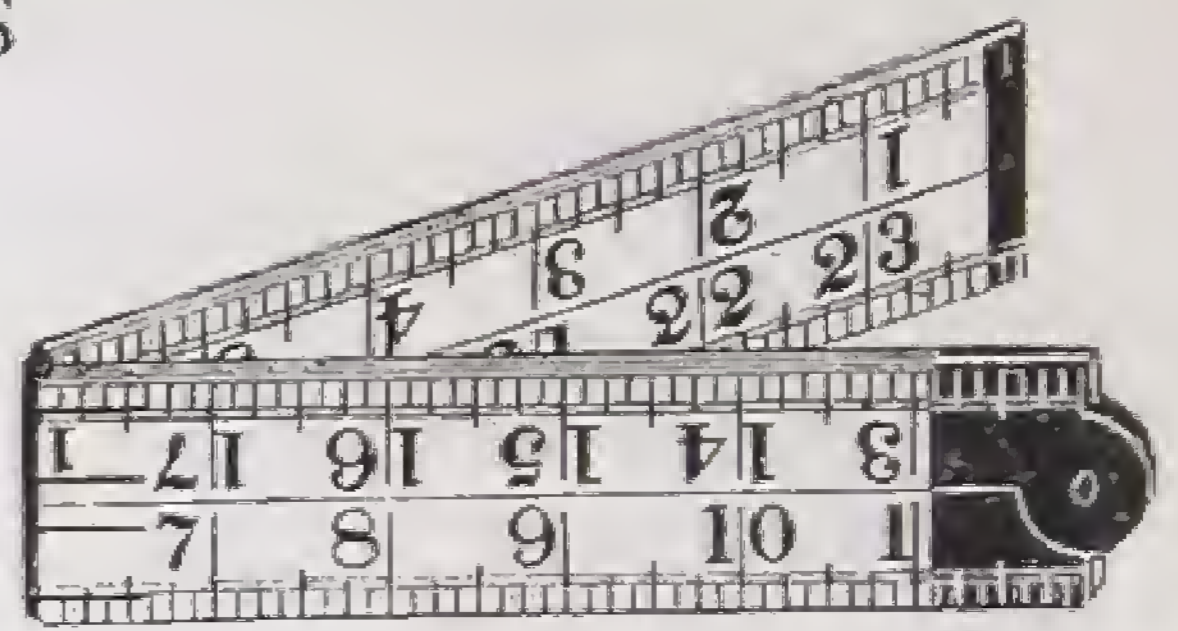

No. M 1441
2-Ft. FOUR-FOLD BOXWOOD
BLIND MAN'S RULE

1½ in. wide, deeply marked in.
8ths and 16ths.

No. M 1442 3 ft., as above

**2-FOOT
STEEL RULE**

No. M 1443
Also supplied
with Brass Tips

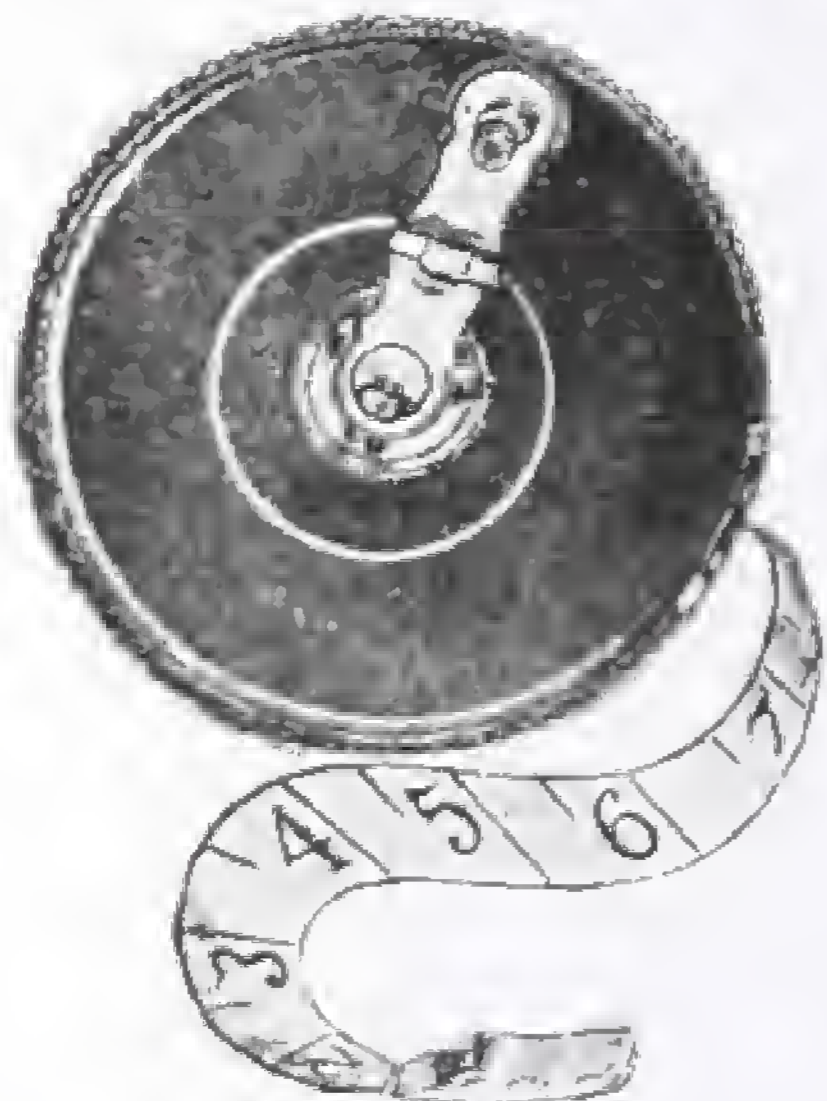
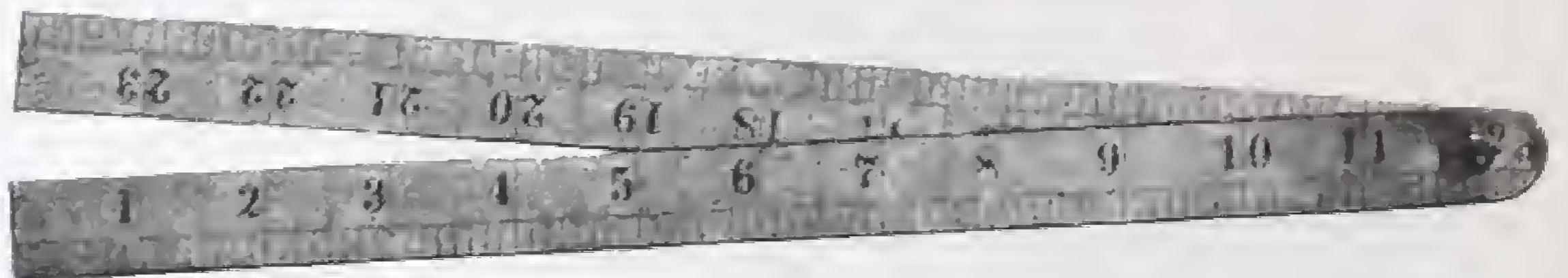

No. M1456
SPIRIT LEVEL

Selected Hardwood.

No. M 1460
NARROW ROSEWOOD
PLUMB AND LEVEL
With Tapered Ends.
Brass Plated and Tipped.
Sizes 6 9 12 in.

METALLIC WIRED TAPE
Marked in Feet (in half-inches) and Links.

No. M 1450
Ordinary Quality, ½ in. wide. Folding handle
Lengths ... 33 50 66 100 feet

No. M 1453
Best Quality, ⅝ in. wide. Flush handle.
Lengths ... 33 50 66 100 feet



Sizes 6 8 10 12 in.

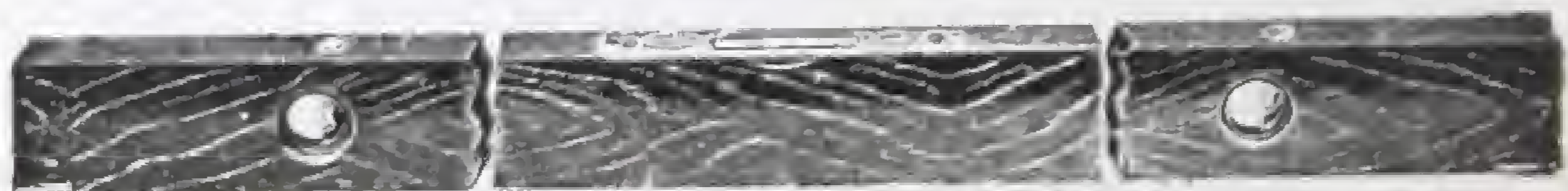

No. M 1792
BUILDERS' LEVEL
Non-adjustable.

Both obtainable in sizes 36, 42, 48 in.

No. M 1793
BUILDERS' LEVEL
Adjustable.

TOOLS

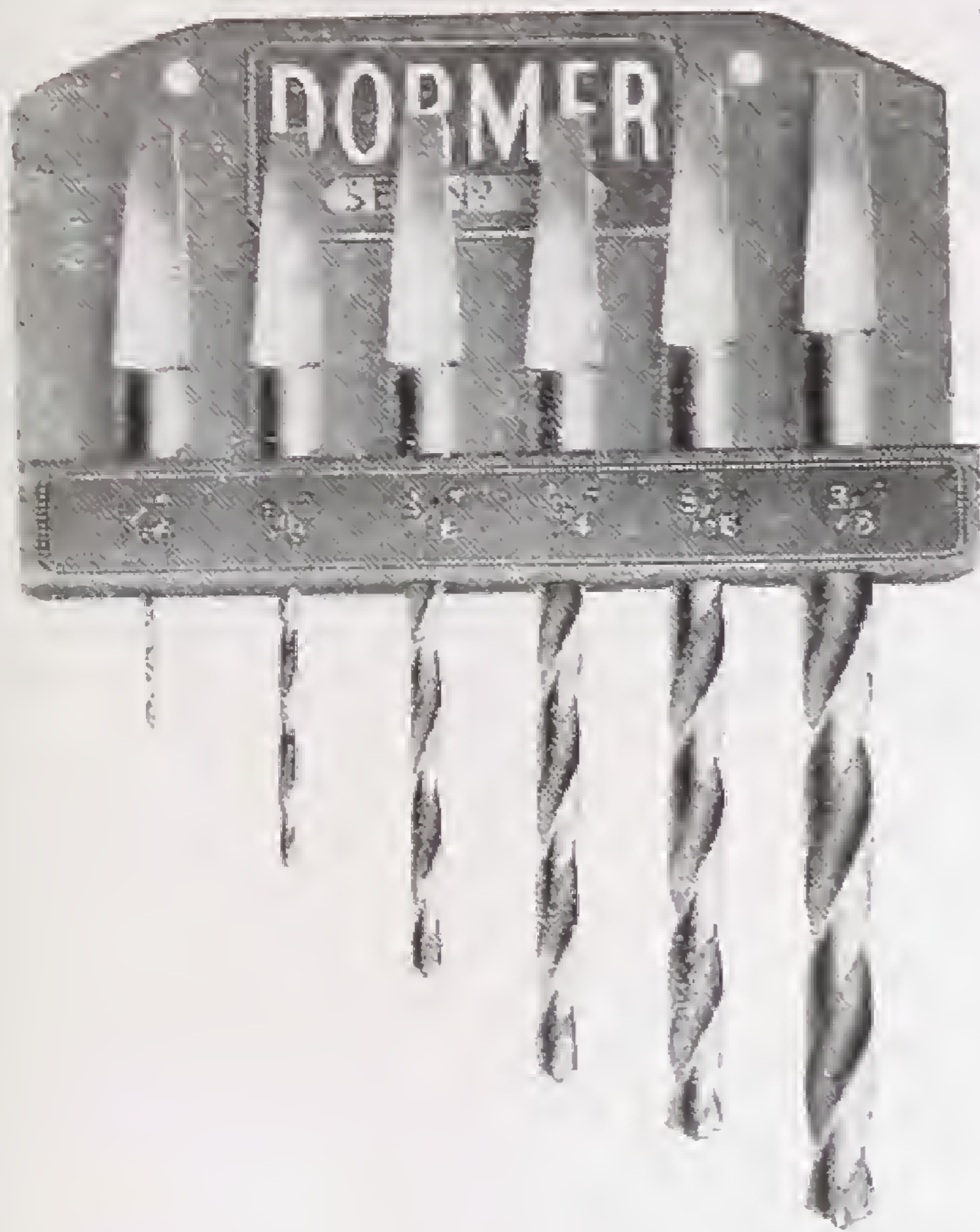

**DORMER DRILLS
IN SETS
COMPLETE WITH
DURAL WALL BRACKET**

Set No.	Range of Sizes Inches	No. of Tools
34	1/16—3/8 by 16ths	6



**No. M 1695
JENNINGS
PATTERN**

Sizes 1/4, 5/16, 3/8, 7/16,
1/2, 9/16, 5/8, 3/4, 7/8, 1,
1 1/4 in.



**No. M 1693
CENTRE BIT**

Cast Steel
Sizes 1/4, 5/16, 3/8, 7/16,
1/2, 9/16, 5/8, 3/4, 7/8, 1, 1 1/4 in.

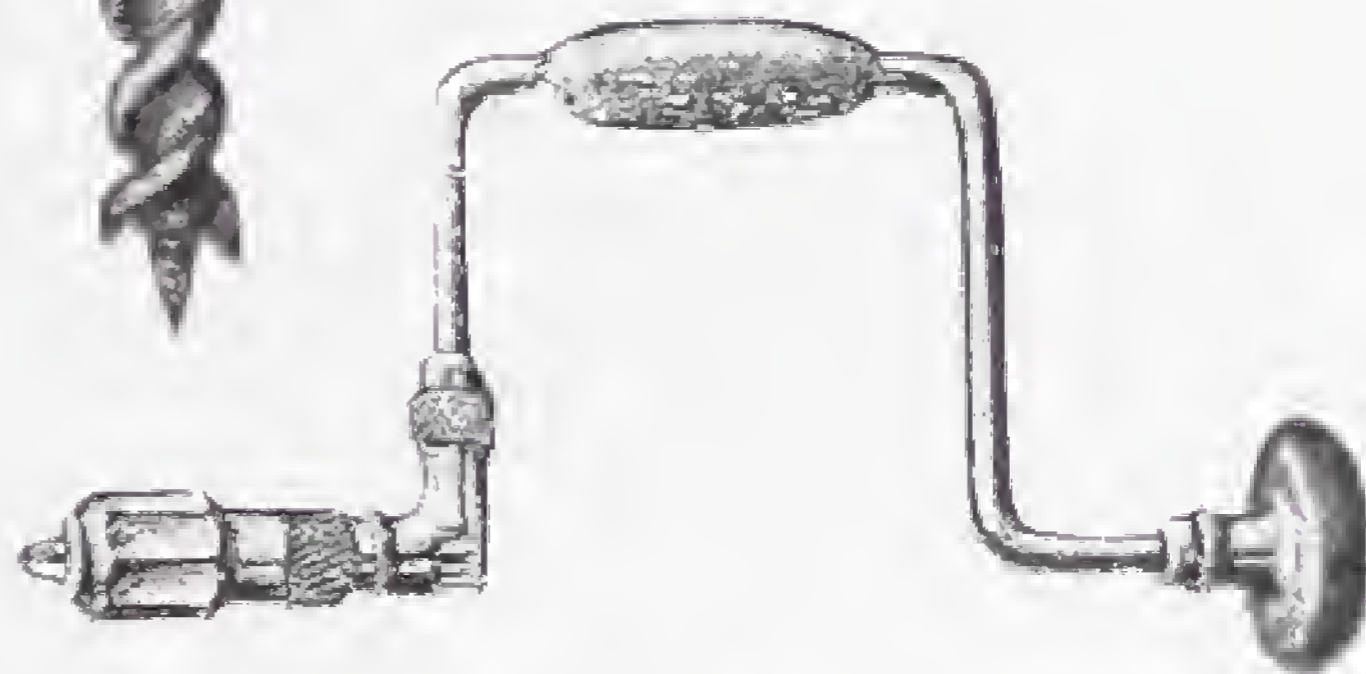

**No. M 1350
BEST BALL-BEARING RATCHET
BRACE**

Bright Fin. 6, 8, 10 in. Sweep

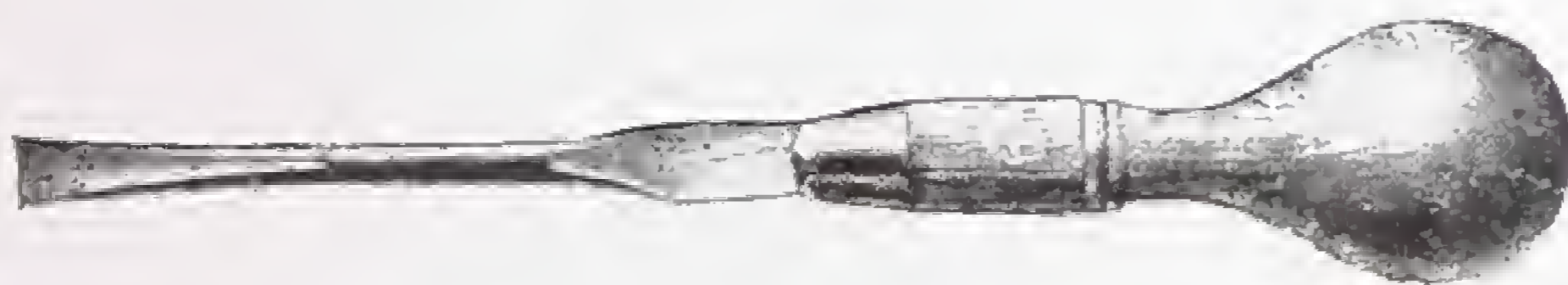

**No. M 1389
BEST CABINET TURNSCREW
Oval Beech Handle
Blades: 3, 4, 5, 6, 8, 10, 12 in.**

**No. M 1397 A
FLOORBOARD STEEL
CHISEL**



No. M 1397 B as above in Non-Temper Steel.

BAXENDALE & CO. LTD.

TOOLS



No. M 533. Bent.

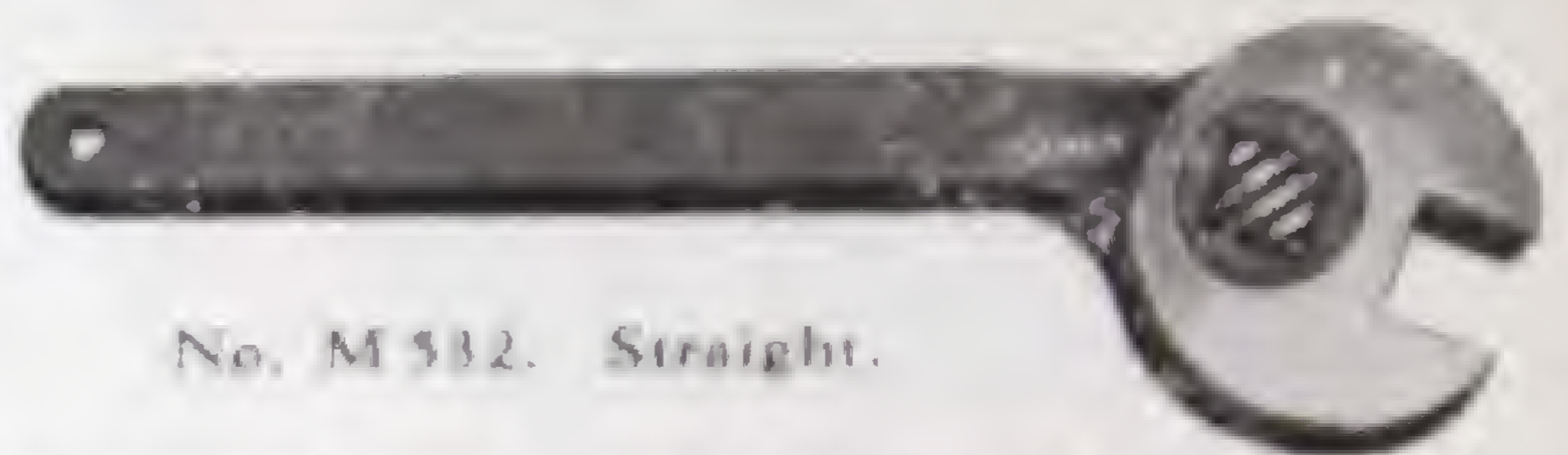

No. M 532. Straight.

CLYBURN SPANNERS—STRONG JAW

Size	2	3	4	5	6
Length	6	8	10	12	15 in.
Span	$\frac{3}{8}$	$\frac{7}{8}$	1	$1\frac{1}{8}$	$1\frac{1}{2}$ in.
Size	7	8	9	10	11
Length	18	21	24	26	28
Span	$1\frac{1}{8}$	2	$2\frac{1}{8}$	$2\frac{1}{2}$	3 in.



No. M1773
ADJUSTABLE
SPANNER

Size	6	8	12 in.
Jaws open	$\frac{1}{4}$	$\frac{3}{8}$	$\frac{1}{2}$ in.

No. M 1229



BACK-NUT PLIERS

Rough Black Finish

Size 12 in.



No. M 811
BASIN WRENCH

For Back Nuts of Lavatory Basins and Bath Taps.

Malleable Iron, 10 $\frac{1}{2}$ in. long; one end $\frac{1}{2}$ in., other end $\frac{3}{4}$ in.

No. M 292
SPANNER—Hardened Jaws



Size ——— $1\frac{1}{8}$ — $1\frac{1}{4}$ — $1\frac{1}{2}$ — $1\frac{3}{4}$ — 2 in.

All other sizes stocked, and also Single Ended Spanners.

MILLER STREET · MANCHESTER

TOOLS

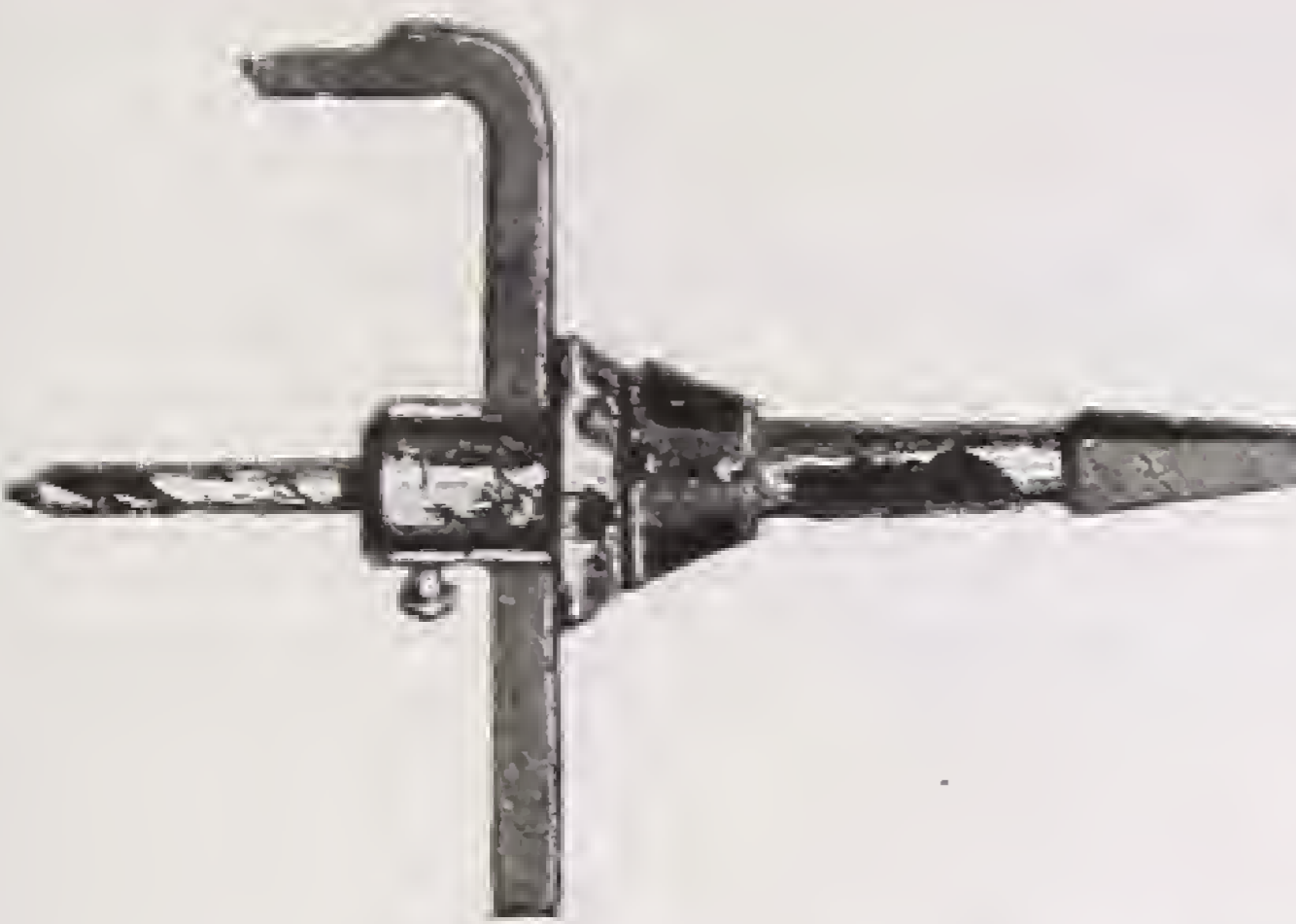

No. M 1194
RING SAW

Used in a
Carpenter's Brace.

No. M 197/A
**ADJUSTABLE EXPANSION
DRILL**

& CIRCULAR METAL CUTTER
Made from solid wrought steel.
Will cut from ½ in. to 5 in. diam.

*Spare Cutters
Spare Drill*

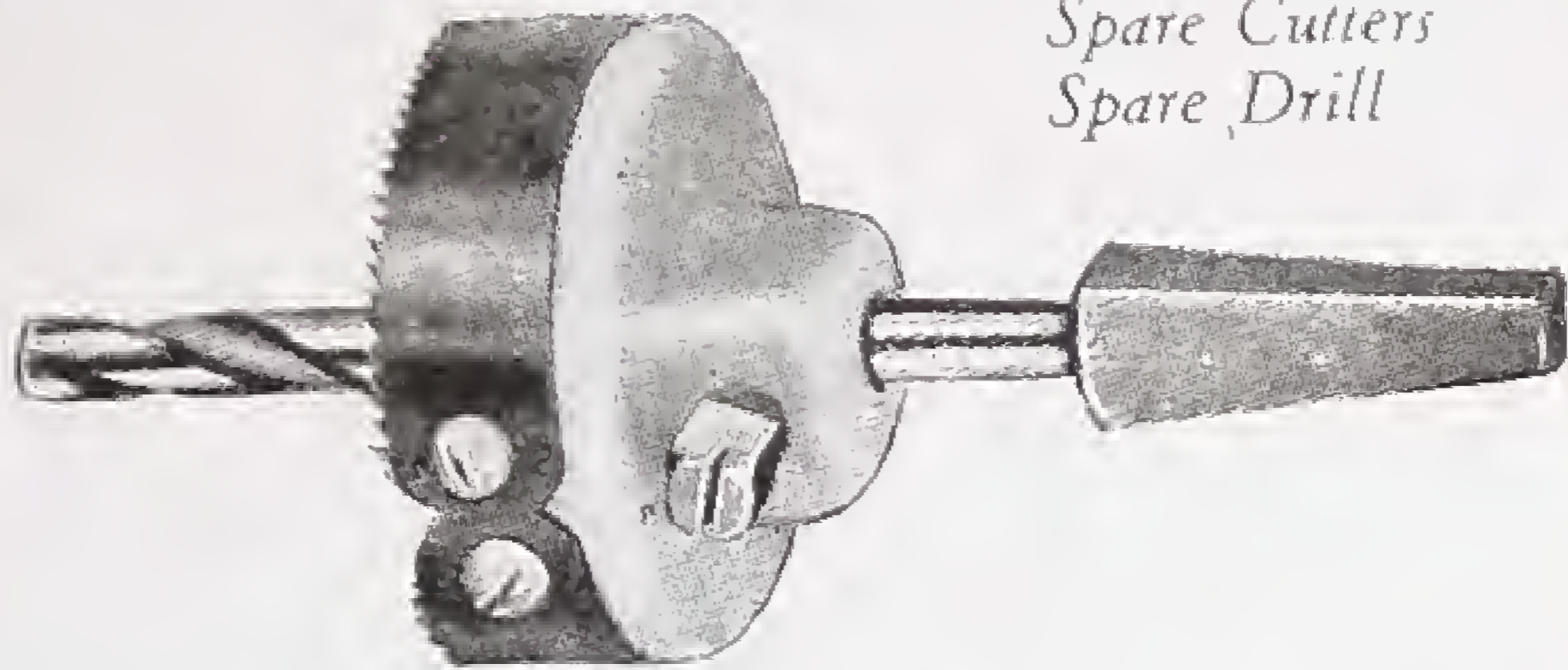

The tool is not adjustable—a separate tool is required for each diameter. Ensures a cleanly cut round hole. Stock tools cut up to ⅓ in. thick. Order specially when for use on thicker materials.

For Gas and Water Trades

Tool No. ...	0	3	6	9	12	15	18	24
Pipe clearing...	½	¾	1	1¼	1½	1¾	2	2½ in.

No. M 392. **UNIVERSAL PIPE
SOLDERING CRAMP**

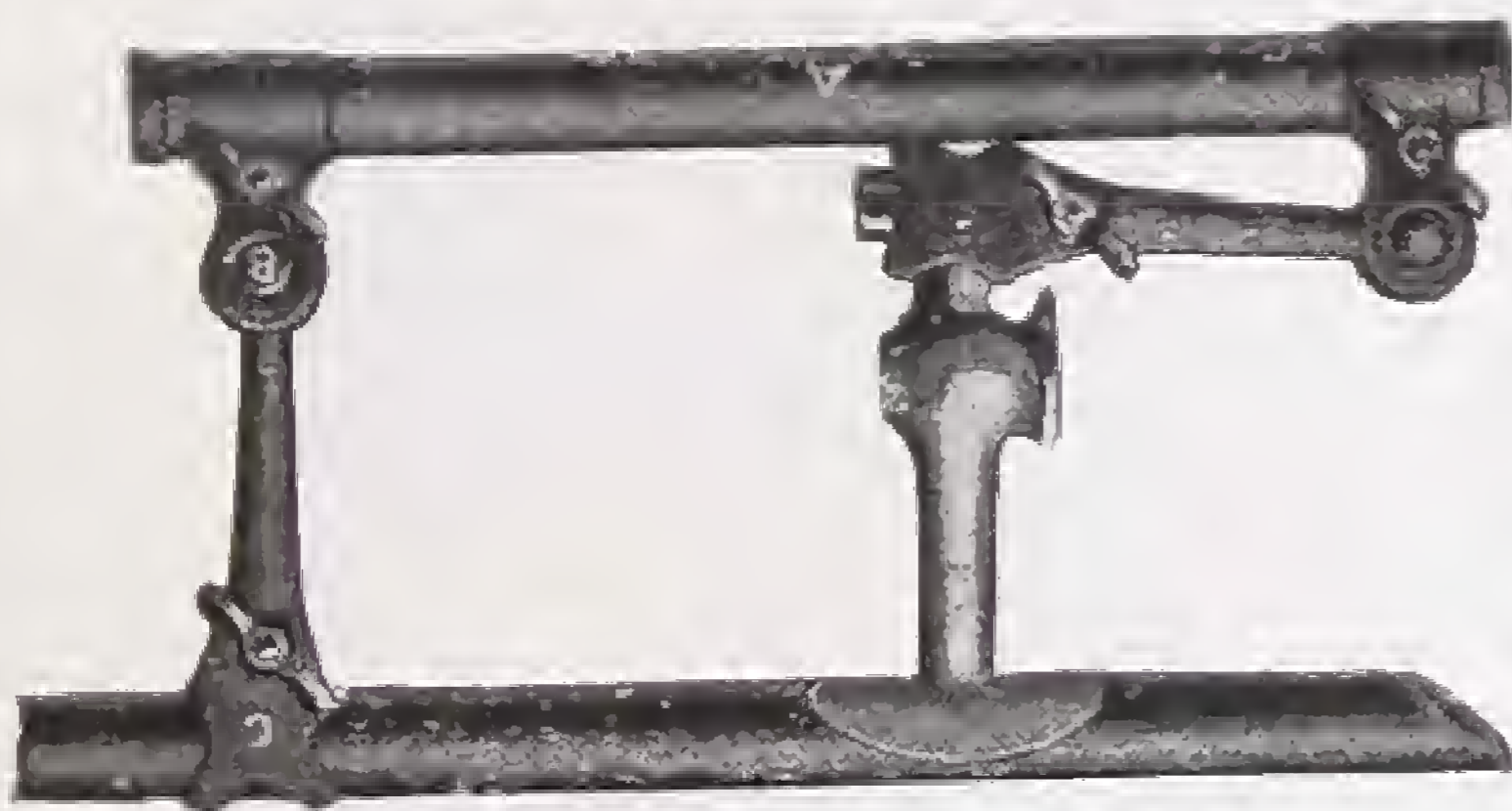

When used horizontally on bench it can be crossed obliquely with line of Pipe, and forms a base for work while joint is being made. It is invaluable where joints have to be made with gas on, as the main cannot slip asunder while being jointed. If only one arm of Cramp is in operation the work can be made perfectly rigid by fixing other arm on an adjoining Pipe, Cistern Edge, Bracket, or any other fixture.

Size of Cramp open, 12½ in. × 7 in.
Closed, 12½ in. × 2¾ in.

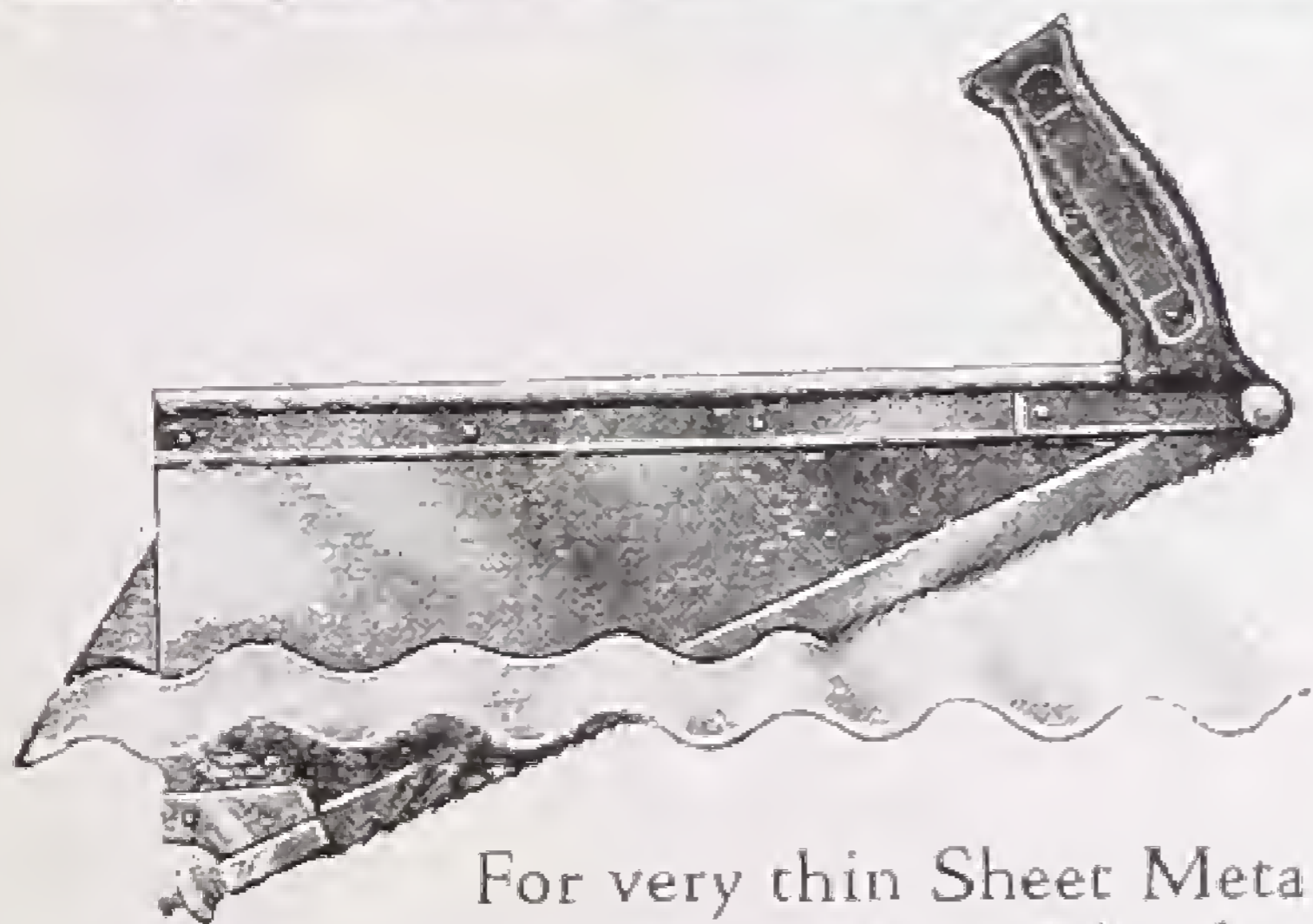

No. M 1198. **SAW**

Strongly constructed with a cast steel blade sufficiently thin to follow the cut of an ordinary 12 in. Hack Saw Blade. Will cut through any width or length of material.

For very thin Sheet Metals use a Blade with 32 teeth to inch

For Thin Sheet Metals	„	„	„	22	„	„	„
For Ebonite, Asbestos, Tiles, etc.	„	„	„	14	„	„	„
For Asbestos Sheets	„	„	„	7	„	„	„

Spare blades can be supplied.

TOOLS



No. M 1357
BEST WARRINGTON
HAMMER
Handled.

Sizes ... 0 1 2 3 4
No. M 1357A. SHAFTS.
Nos. 0, 1, 2, 3, and 4

No. M 1352
SHAFTS
For Adze Eye
Hammers.
14 in. (for all sizes).

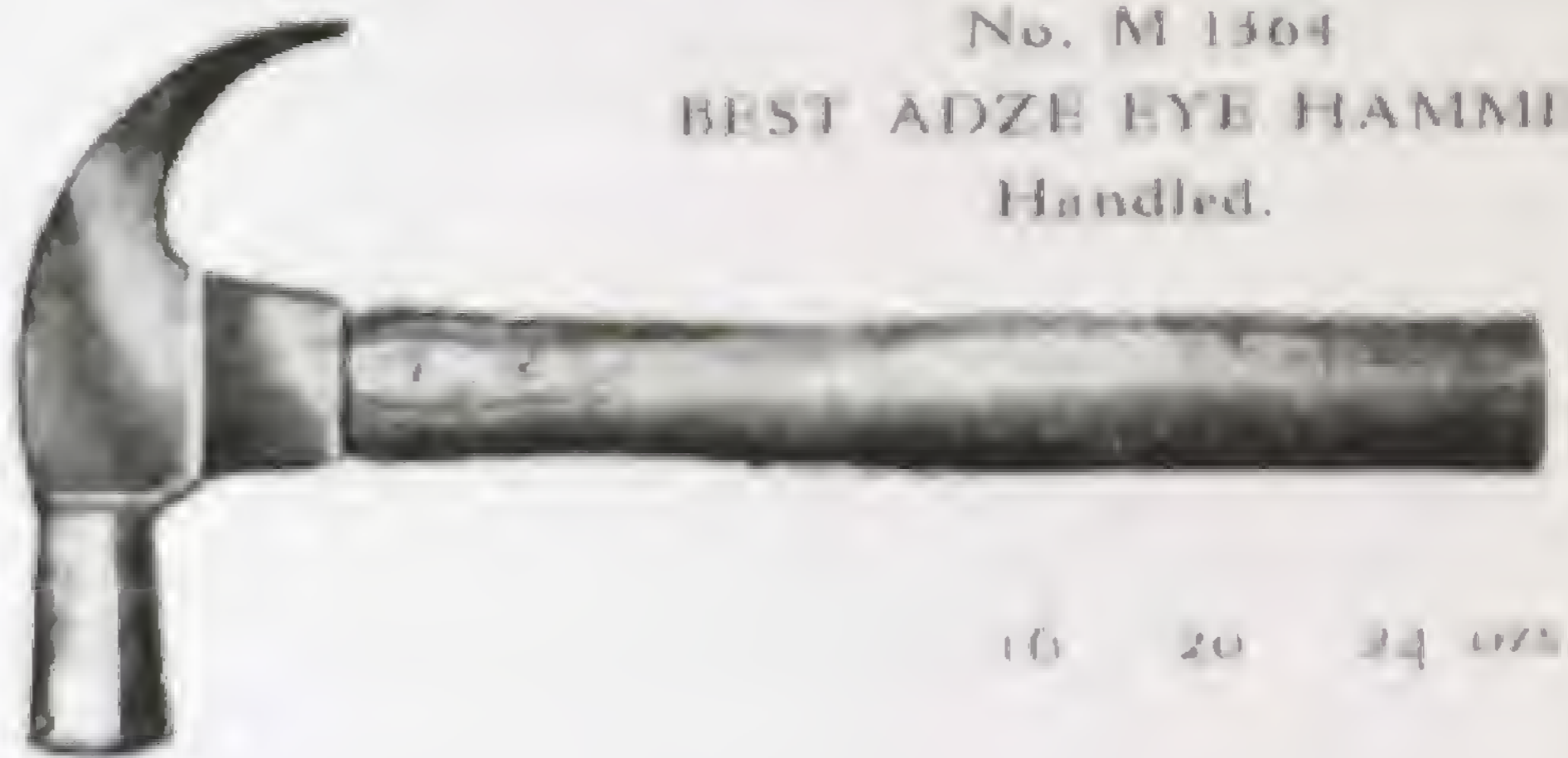

No. M 1364
BEST ADZE EYE HAMMER
Handled.

10 20 24 ozs.



No. M 1358
BALL PEIN
Heads, Ball or Cross Pein
 $\frac{1}{2}$ lb. and $\frac{3}{4}$ lb.



No. M 1359
CROSS PEIN
1 lb. to 3 lb.

Handled -
1 1 $\frac{1}{2}$ 2 2 lbs.

No. M 1595
LUMP
HAMMER

Handled

$\frac{3}{4}$ 4 lb.



No. M 1700A
LATH HAMMER
Strapped

Sizes ... 1 4



No. M 1594
WALLING
HAMMER
Handled

2 4 4 lb.

TOOLS

No. M 1401

HACK SAW FRAME

Nickel-plated, extending for blades, 8 in. to 12 in. Made in 3 qualities.



No. M 1403
**HACK SAW
BLADES**

Hard all through. Warranted Quality. No extra charge for Fine Teeth.

A ...	Size 9 in. × ½ in.	× 18, 24, or 32 teeth per in.
B ...	„ 10 in. × ½ in.	× „ „ „
C ...	„ 12 in. × ½ in.	× „ „ „

No. M 1404
**DOUBLE EDGE
BLADE**

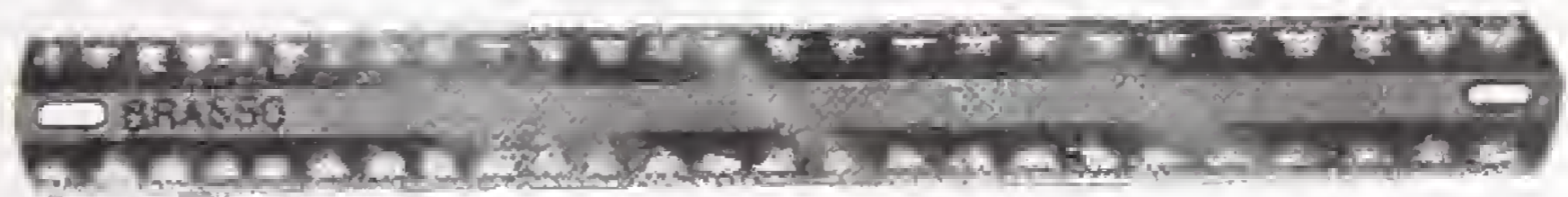

10 × 1 in.

12 × 1 in.

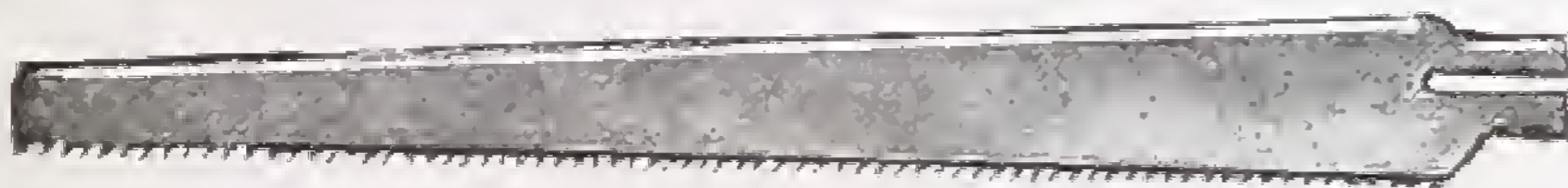
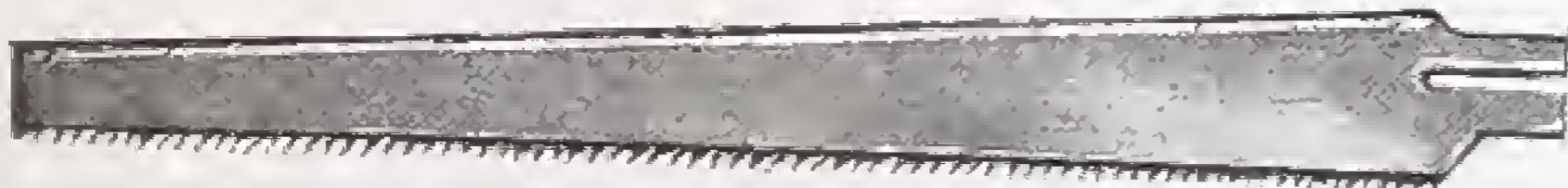

No. M 1369
**3-SAW SET
INTERCHANGEABLE
SAWS.**

Best Quality.

Saws, 10 in., 14 in., and 16 in. long respectively

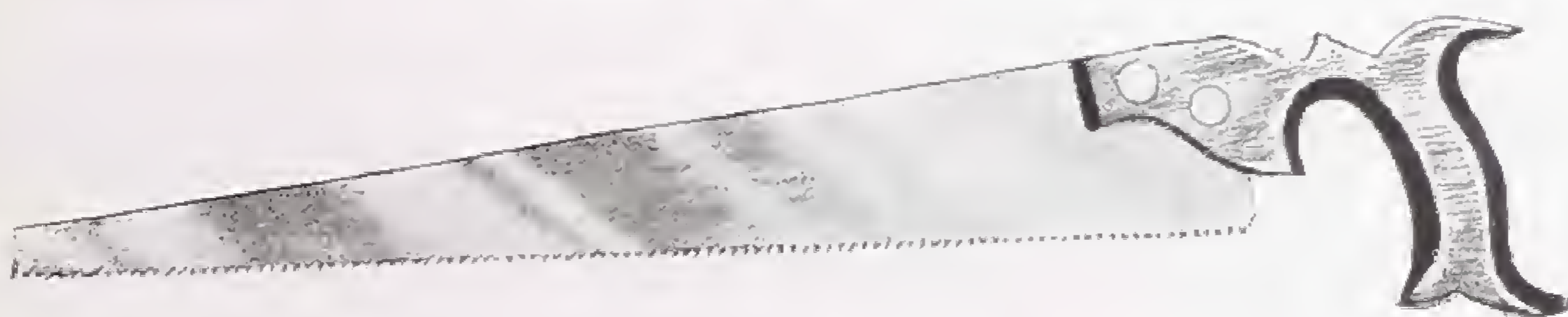

No. M 1710A. **PLUMBER'S SAW** 18 in. Blade.

BAXENDALE & CO. LTD.

TOOLS



No. M 1408
COLD STEEL CHISELS

Size	6 x 1/2	8 x 1/2	10 x 1/2	10 x 1/2	10 x 1/2	12 x 1/2 in.
Size	14 x 1/2	12 x 1/2	18 x 1/2	18 x 1/2	24 x 1/2	in.

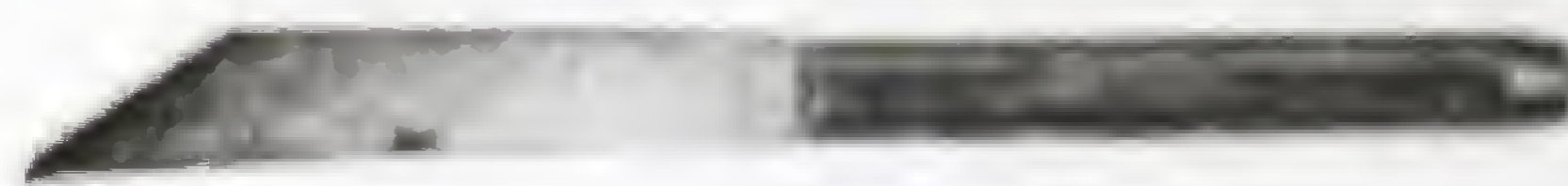

No. M 1395
CAST-STEEL
PLUGGING CHISELS

Size	9 x 1/2	9 x 1/2	9 x 1/2	10 x 1/2	12 x 1/2 in.
------	---------	---------	---------	----------	--------------

No. M 1407
DIAMOND
DRILL POINT

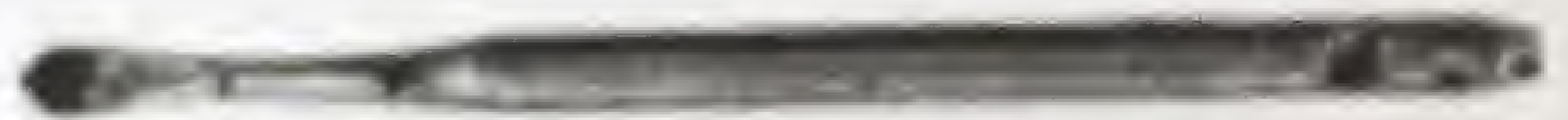

Size	9 x 1/2	10 x 1/2	12 x 1/2	12 x 1/2 in.
------	---------	----------	----------	--------------

No. M 1409
CROSS
SECTION DRILL



Size	9 x 1/2	10 x 1/2	12 x 1/2	18 x 1/2	18 x 1/2	24 x 1/2	18 x 1/2	24 x 1/2 in.
------	---------	----------	----------	----------	----------	----------	----------	--------------

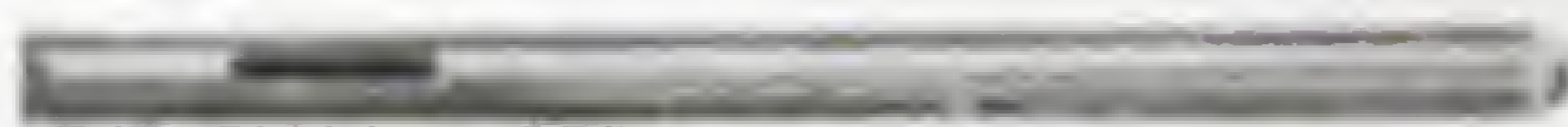

No. M 1410
CROWN HOLLOW
END DRILL

Size	9 x 1/2	9 x 1/2	10 x 1/2	10 x 1/2	12 x 1/2 in.
------	---------	---------	----------	----------	--------------



No. M 1411
CAULKING CHISELS
Set of 6 standard shapes

TOOLS

No. M 1232

COMBINATION PLIERS
With Burner Hole and
Two Wire Cutters.



Flat Nose. Sizes ... 6 7 8 in.

No. M 1237
**COMBINED GAS
PLIERS**



With Wire Cutter, Pipe Opener and Turnscrew.

Sizes 6 7 8 9 in.

No. M 1398

END CUTTING NIPPERS



Sizes 4 5 6 in.

No. M 1380

PINCERS

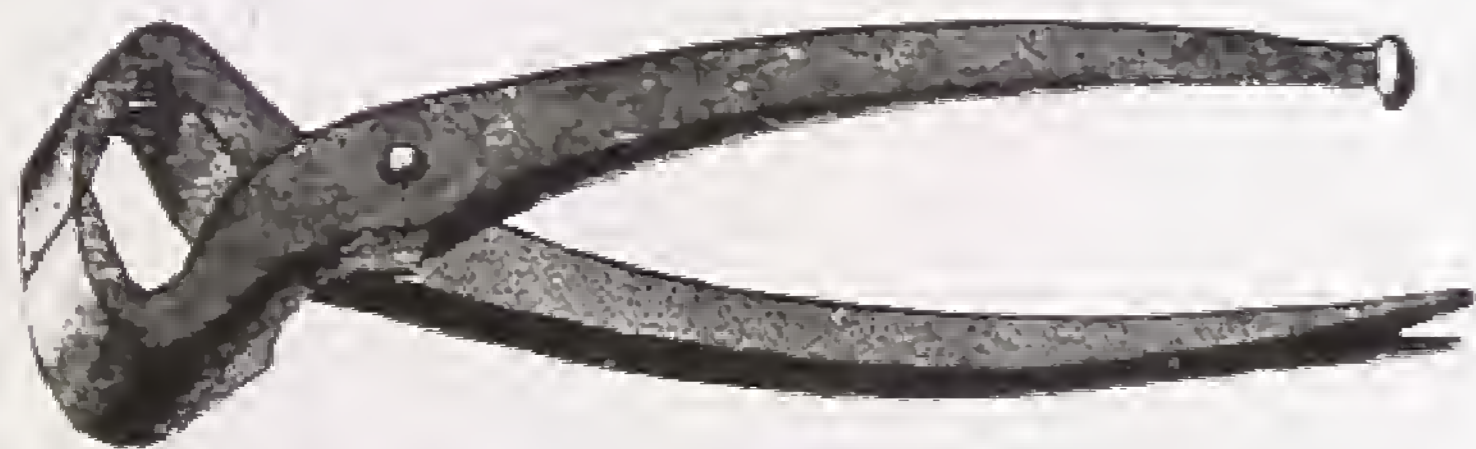

Sizes 6 7 8 9 in.

No. M 245

FOOTPRINT WRENCH
Black



Length ... 5 $\frac{3}{4}$ 7 9 12 14 16 in.
Span ... $\frac{1}{16}$ to $1\frac{1}{2}$ $\frac{1}{16}$ to $1\frac{1}{2}$ $\frac{1}{8}$ to $2\frac{1}{2}$ $\frac{1}{4}$ to 3 $\frac{1}{4}$ to 3 $\frac{1}{2}$ to $3\frac{3}{4}$ in.

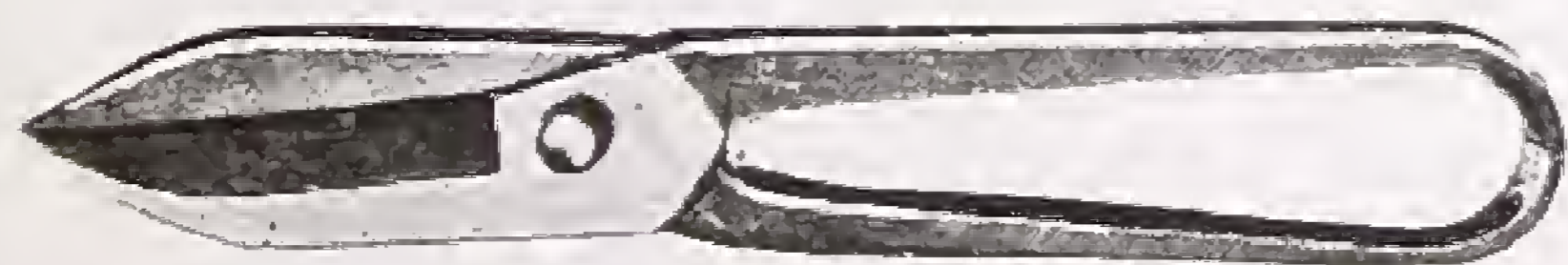

**WARRANTED TINMAN'S
SNIPS**

Straight Blades, No. M 1382. Bent or Curved Blades, No. M 1383.
Sizes ... 6 7 8 9 10 11 12 14 16 in.

TOOLS



No. M 964. **STRAIGHT SOLDERING IRON**
With Wood Handle

Sizes 4 6 8 10 12 16 ozs. and upwards

No. M 965. **HATCHET SOLDERING IRON**
With Wood Handle

Sizes 4 6 8 10 12 16 ozs. and upwards



THE SOLON ELECTRIC SOLDERING IRON
Fitted with 6 oz. Bit.

Consumption by watts: Supplied complete with 6 ft. Twin Flexible Cord.



No. M 280.

CAST-IRON METAL POT

Sizes 6 8 10 12 14 16



No. M 276

WROUGHT-IRON PLUMBERS' LADLE

Sizes 3 4 5 6 8 10 12

These are strong Ladles - Handle and Bowl in one piece

No. M 281. **GULLEY LADLE**
With Long Handle

Sizes 3 4 5 6 8 10 (Bowl)



No. M 199 **PLUMBERS' GOUGE**
With Beechwood Handle.

Sizes 1 2 3 4 5 6 8 10

TOOLS



No. M/1112A BLOW LAMP

1 in. diameter

No. M/1112B SHORT NECK

1½ in. diameter

No. M 1112A



No. M 1113
LONG NECK BLOW LAMP

Diameter of Body, 1½ in.

Length of Body, 4½ in.

Length of Neck, 3½ in.

No. M 1113

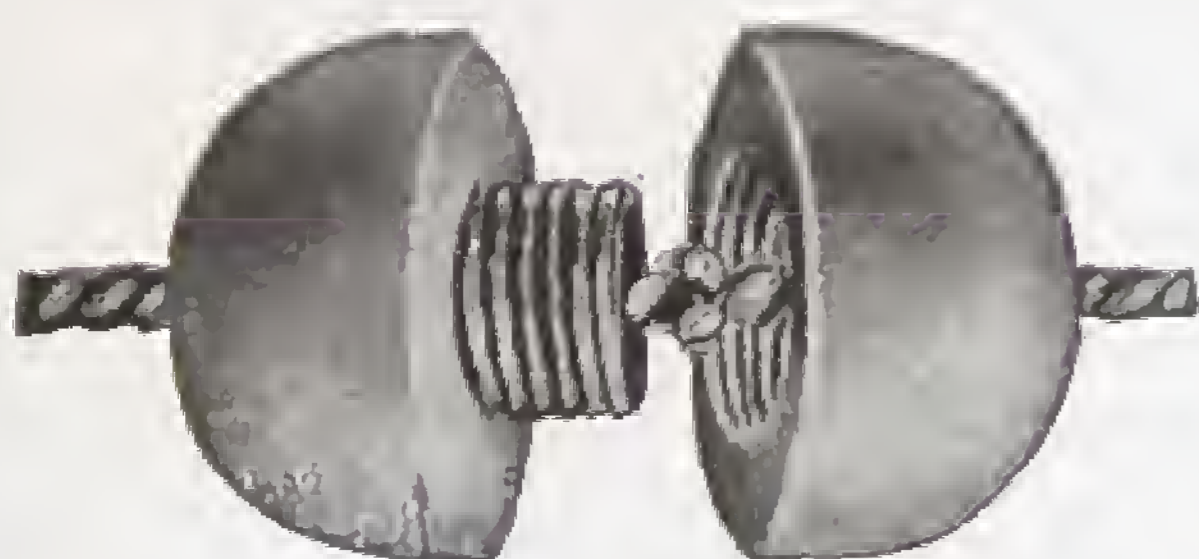

No. M 1518
BRASS FOLLOWER OR
BOBBIN DRIVER
True in Diameter.

Recessed in centre to prevent cutting of cord.

Dia. of Pipe... 1 1¼ 1½ 2 2½ 3 3½ 4 in.



No. M₁1310
WIPING CLOTHS

2½ × 1½ in. 4 × 3 in.

4½ × 3½ „ 5 × 4 „



No. M 8C. BLOW PIPE FOR GAS
With Improved Control Tap arrangement; Gas and Air supplies independent and under control of one finger.

Sizes... 1 2 3 4
Gas Supply ... ⅜ for ⅜ ½ for ½ ¾ for ¾ 1 for 1 in.

No. M 1311
MOLESKIN WIPING CLOTH

Best Quality only.
Approx. 29 in. wide



BASSES

M 402 A. Canvas Lined with Straps

Sizes ... 3 4 5

M 403. Leather Lined with Straps

Sizes ... 3 4 5

TOOLS



No. M 1412B
BRICKLAYER'S
HAMMER
LONG HEAD



No. M 1411
MORTAR PICK



No. M 1414B
SLATER'S HAMMER
Work Claw
Cast Steel
No. M 1414A
Wrought Steel

No. M 1411A
SHORT HEAD



No. M 1418 B
SLATER'S KNIFE OR ANVIL

SLATE RIPPER. *Solid Steel.*

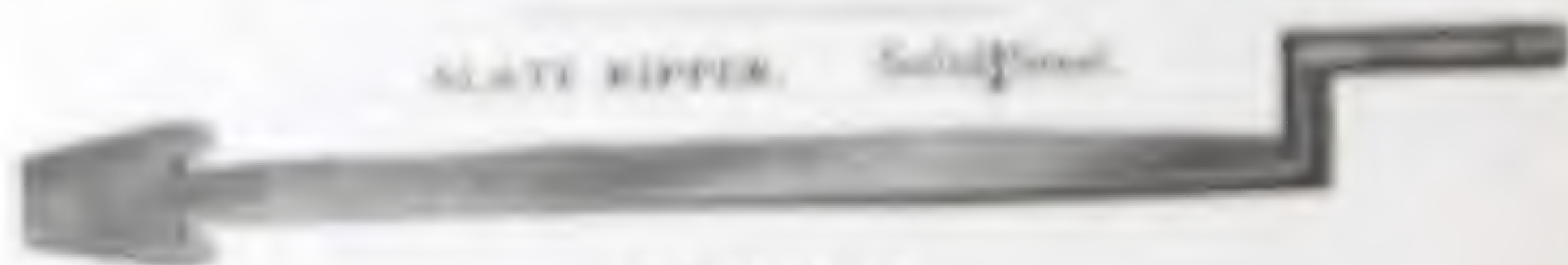

No. M 1421A



POINTING TROWEL

No. M 1417 C Size 5 6 7 1/2

No. M 1417 A 8 1/2

BRICK TROWELS

Size 10 11 12 1/2

No. M 1416 No. M 1415 Wide Pattern 10, 11, 12 1/2

We have a complete list of Carpenters' Tools and Plans, and shall be pleased to send a copy on request.

TOOLS

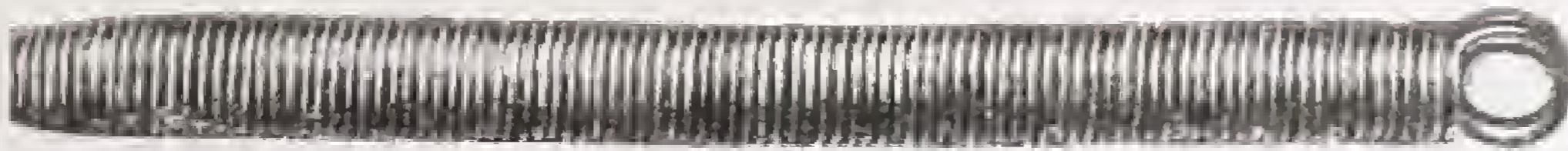

No. M 570. PIPE BENDER

For Pipes ... 1 $1\frac{1}{4}$ $1\frac{1}{2}$ 2 $2\frac{1}{2}$ in.



No. M 571
CLIMAX
PIPE
BENDER

Made of Best Steel Wire, with Convex Face, does not injure the Lead Pipe.

For Pipes ... $\frac{1}{2}$ $\frac{3}{4}$ 1 $1\frac{1}{4}$ $1\frac{1}{2}$ 2 in.

If required for light copper, state so when ordering.



No. M 572. IMPROVED PIPE BENDER

The edges of the wire are slightly depressed below the surface, so as to facilitate withdrawal from bends. An iron rod can be fastened to Spring for the purpose of making bends any distance from end of Pipe.

For Pipes ... $\frac{3}{4}$ 1 $1\frac{1}{4}$ $1\frac{1}{2}$ 2 in.



No. M 1300
BENDING BOLT
OR PIN

Lengths... 9 12 in.



No. M 393
BAILEY'S PIPE JOINTER



THE BURLOC
FIXING TOOL

No. M 1224

For holding
Plumbers' Unions in
straight joints only.

Sizes ... 0 1 2
For Pipes ... $\frac{3}{8}$ to $\frac{1}{2}$ in. $\frac{1}{2}$ to $\frac{3}{4}$ in. $\frac{3}{4}$ to $1\frac{1}{2}$ in.



No. M 1648
BOBBINS

No. M 1648A
TURNPINS

Sizes ... 1 $1\frac{1}{4}$ $1\frac{1}{2}$ $1\frac{3}{4}$ 2 3 $3\frac{1}{2}$ 4 in.

TOOLS



No. M 1222.

SCREW-DOWN PIPE OPENER

Simplifies the opening of Lead Pipes for branch making. It is easier and quicker to manipulate than the usual type. It also ensures a perfectly square joint.

No. M 1190

CUTTER FOR CUTTING SHEET LEAD, ZINC, AND OTHER SOFT METALS

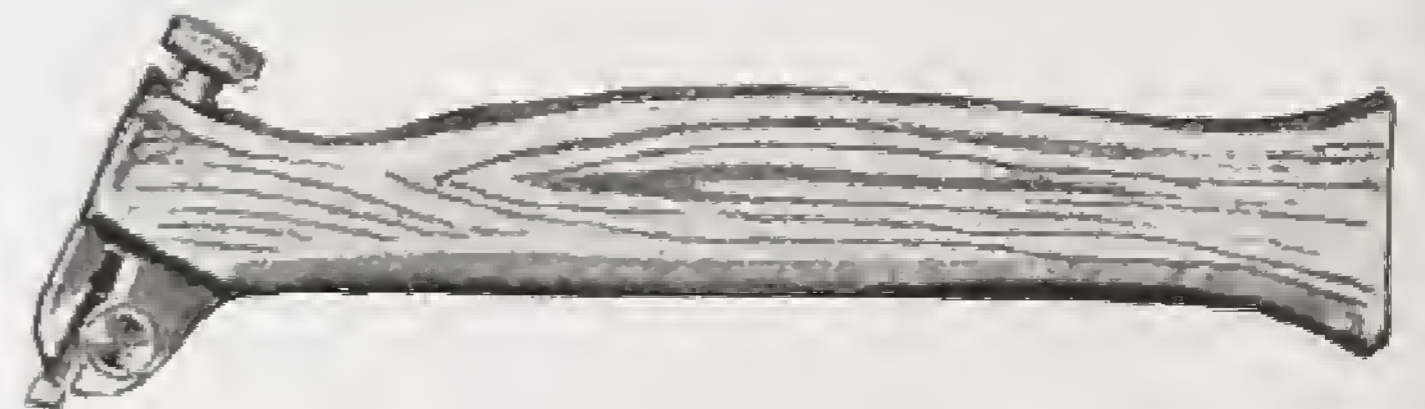

Handle is of Aluminium, Cutter is of Carbon Steel with 2 Bevelled Edges securely held in either side of head with Locking Screw.

It Cuts a Groove in the Metal and is a Labour Saving Tool. Extra Cutters can be supplied.



No. M 202

HACKING KNIFE

Best. $4\frac{1}{2}$ in. Blade. 3 Rivets,

No. M 397. **HEART PATTERN SHAVE HOOK**



No. M 398

TRIANGULAR SHAVE HOOK

No. M 401
POCKET KNIFE
Horn Handle.



TOOLS

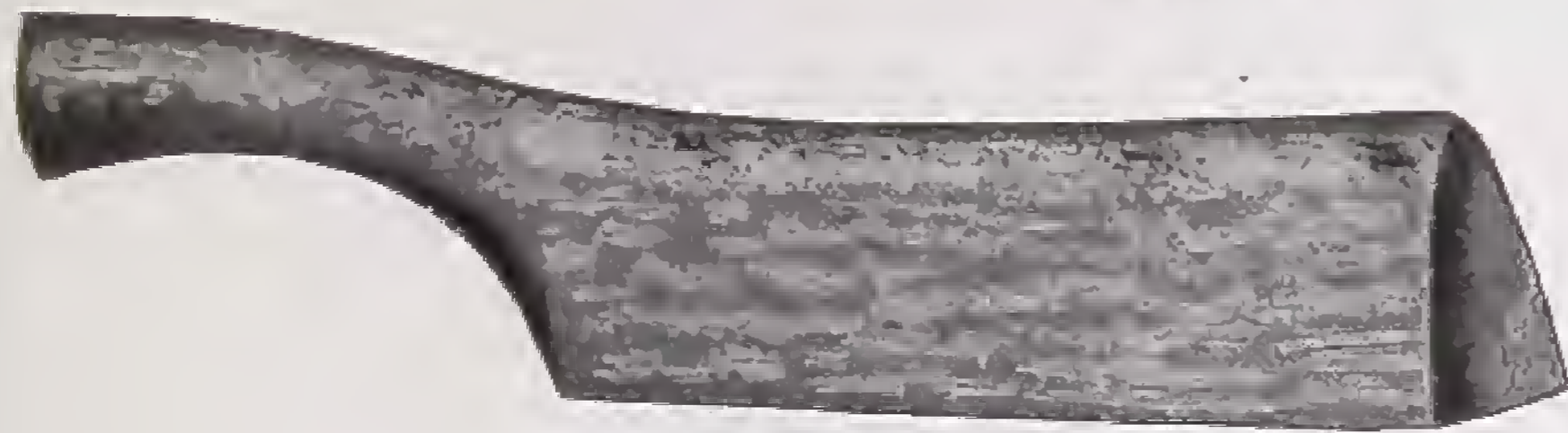

No. M 1637
DRESSER OR
LEAD BEATER
BOXWOOD

Nos.	Ex. Small, 1	Small, 2	Medium, 3	Large, 4	Ex. Large 5
Size	1 $\frac{3}{4}$ × 7	2 × 7 $\frac{1}{2}$	2 $\frac{1}{4}$ × 8	2 $\frac{3}{8}$ × 8 $\frac{1}{2}$	2 $\frac{1}{2}$ × 9 in.

No. M 1639
BENDING STICK,
BOXWOOD

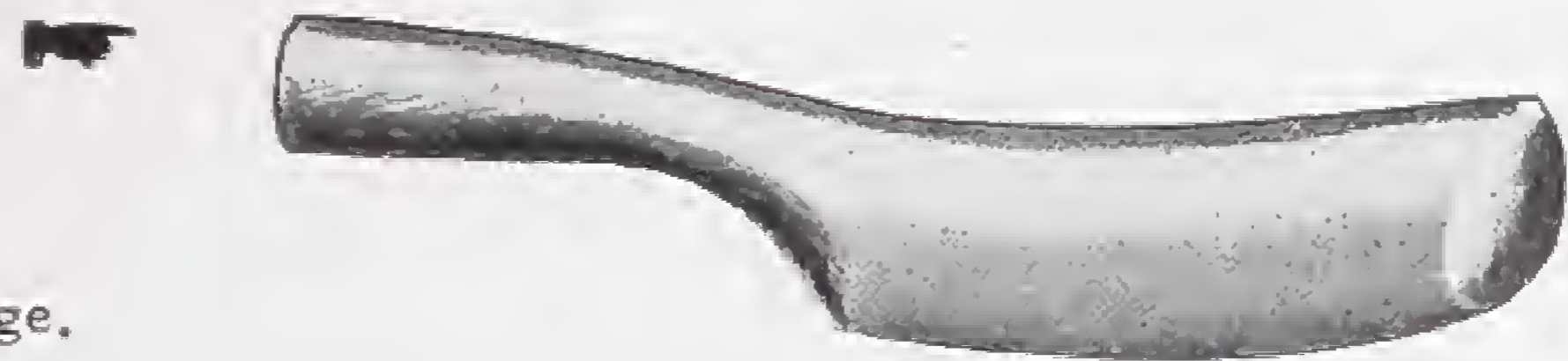

Small. Medium. Large.

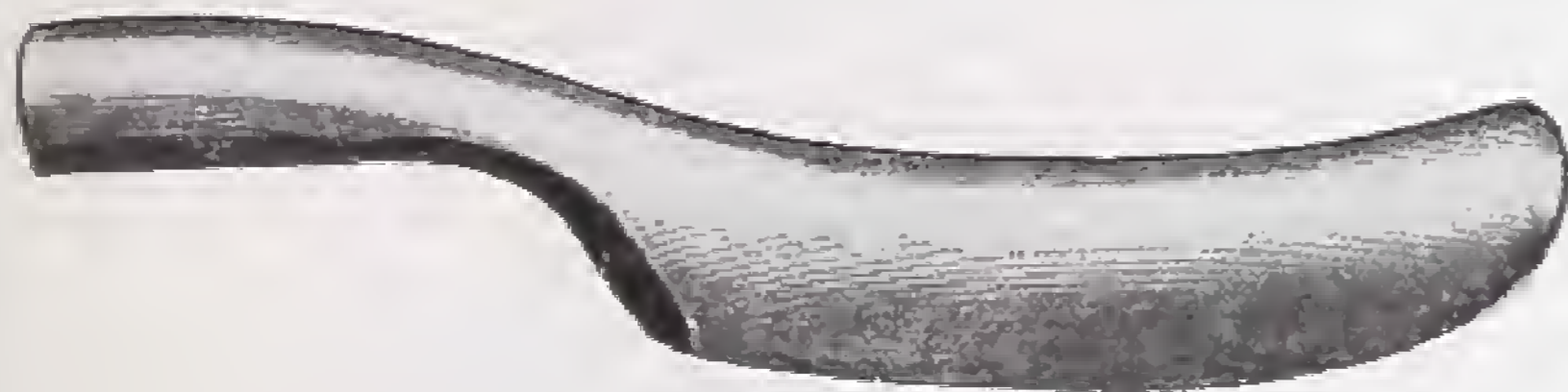

No. M 1638
BOSSING STICK,
BOXWOOD

Small Medium Large

No. M 1642
BOSSING MALLET

Boxwood and Lignum-Vitae
Heads. Selected Malacca
Cane. Unbreakable Handle.
Highly Finished.



Dia. of Face	1 $\frac{1}{4}$	1 $\frac{1}{2}$	1 $\frac{3}{4}$	2	2 $\frac{1}{4}$	2 $\frac{1}{2}$	2 $\frac{3}{4}$	3	3 $\frac{1}{4}$	3 $\frac{1}{2}$ in.
--------------	-----------------	-----------------	-----------------	---	-----------------	-----------------	-----------------	---	-----------------	---------------------

No. M 1322
TINMAN'S MALLET

Heads of Boxwood and
Lignum Vitae with Ash
Handle.

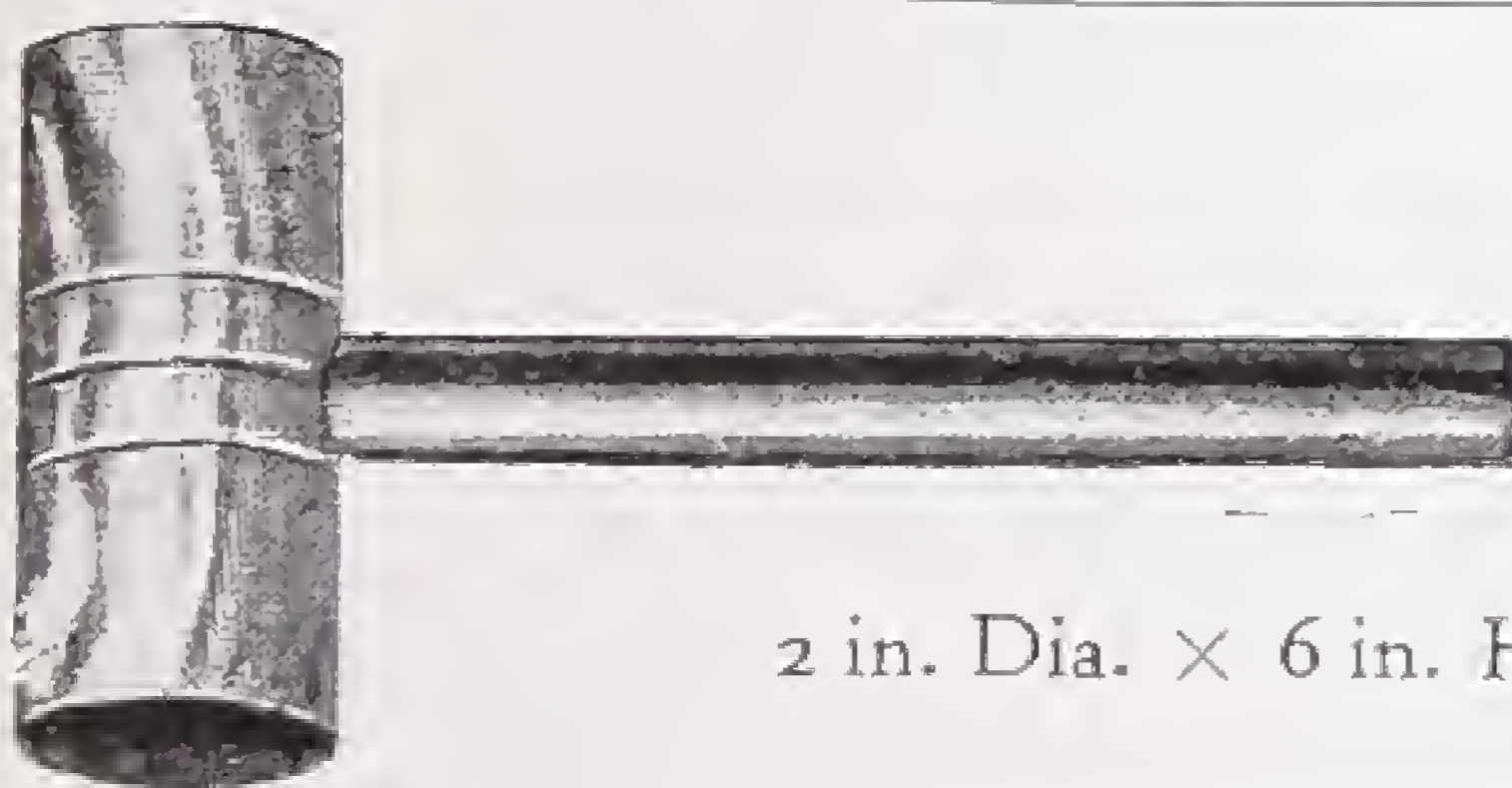

2 in. Dia. × 6 in. Head 3 in. Dia. × 6 in. Head



No. M 1321. MANDRIL. Boxwood and Lignum-Vitae.

Sizes ..	5 $\frac{1}{2}$ × 1	6 × 1 $\frac{1}{4}$	7 × 1 $\frac{1}{2}$	8 × 2	10 × 2 $\frac{1}{2}$	12 × 3	13 × 3 $\frac{1}{2}$	15 × 4 in.
----------	---------------------	---------------------	---------------------	-------	----------------------	--------	----------------------	------------

LONG BEECH MANDRILS—Prices on Application.

TAP RESEATING TOOLS



No. M 1920
THE "ACFIB" RESEATING TOOL

comprising:
Five Flat Cutters— $\frac{1}{4}$ in., $\frac{1}{2}$ in., $\frac{3}{4}$ in.,
1 in., $1\frac{1}{2}$ in.

No. M 1921

THE "TAYLOR HOWIE" COMBINED RESEATING TOOL

For Standard and Fine Threads—
For $\frac{1}{4}$ in., $\frac{1}{2}$ in., $\frac{3}{4}$ in., and 1 in. taps
and for Ball Taps $\frac{1}{4}$ in. and $\frac{1}{2}$ in.

THE "TAYLOR HOWIE" BALL TAP RESEATING TOOL
For $\frac{1}{4}$ in. and $\frac{1}{2}$ in. Ball Taps.



No. M 1922
GORDON WATER AND PUMP GLAND NUT PLIERS

No. 601—24 in. in cardboard carrier.
No. 602—4 $\frac{1}{2}$ in. in leatherette wallet.

A separate list of Contractors' Tools
sent on request.



**TYERS PORTABLE
OIL FURNACES**

No. M 589

Horizontal or Upright Models at same prices.

Each Furnace is supplied with Bucket Rest OR Pipe Cover.

Orders should specify which is required. If BOTH supplied one is charged extra.

SIZE	SPECIFICATION		OIL CAPACITY
No. 1	Heats 1 in.	Pipe and Melts 10 lbs. metal	2 Pints
No. 2	" 1½ in.	" " 16 lbs. "	3 "
No. 3	" 2 in.	" " 28 lbs. "	5 "
No. 4	" 2½ in.	" " 56 lbs. "	7 "
No. 5	" 3 in.	" " 1 cwt. "	9 "
No. 6	" 4 in.	" " 2 cwt. "	12 "

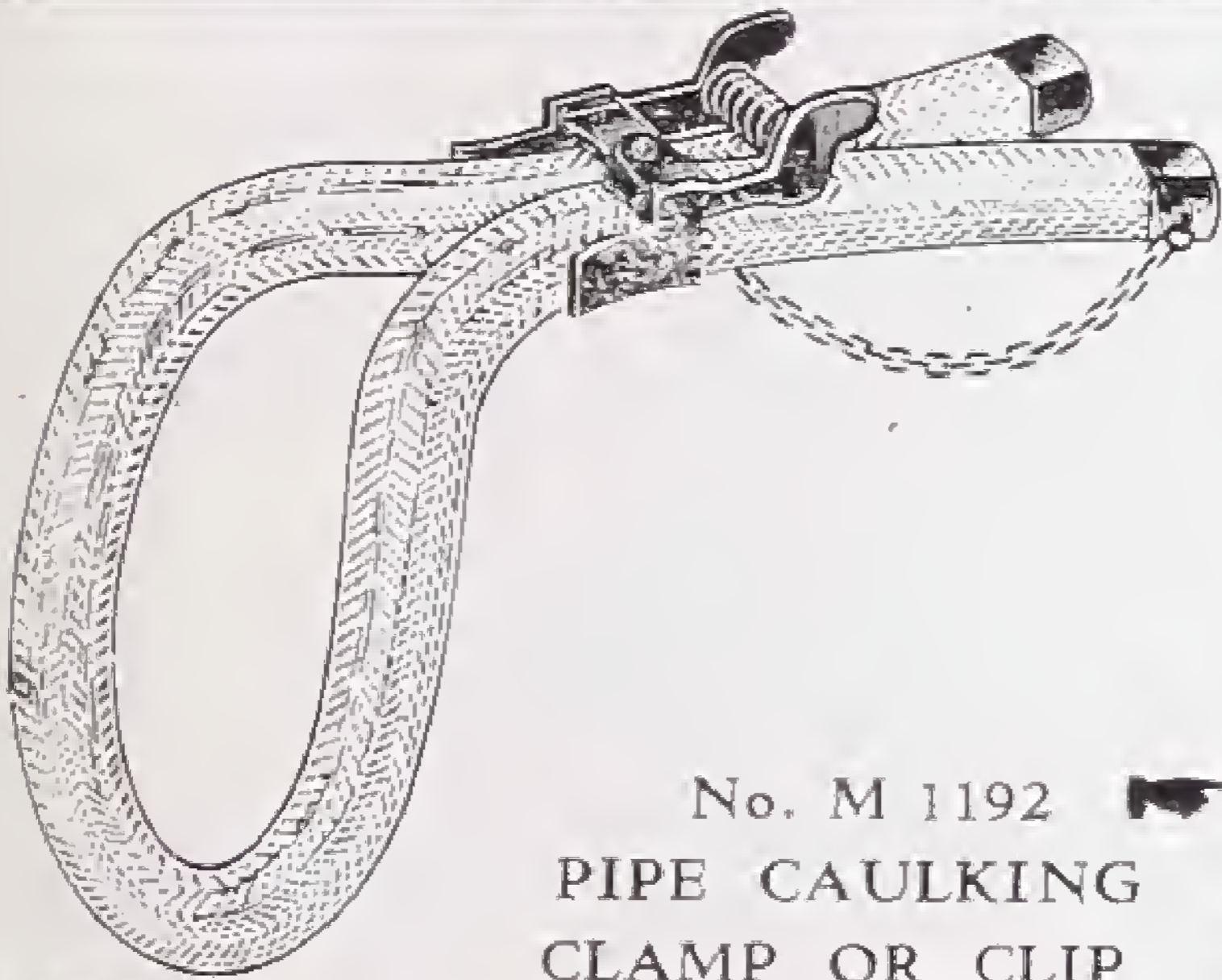

No. M 1192
**PIPE CAULKING
CLAMP OR CLIP**

With Steel Band and Locking Clamps. For 2 in. to 24 in. diameter mains.

Sizes 2 in. to 12 in.

Other Sizes to Order.

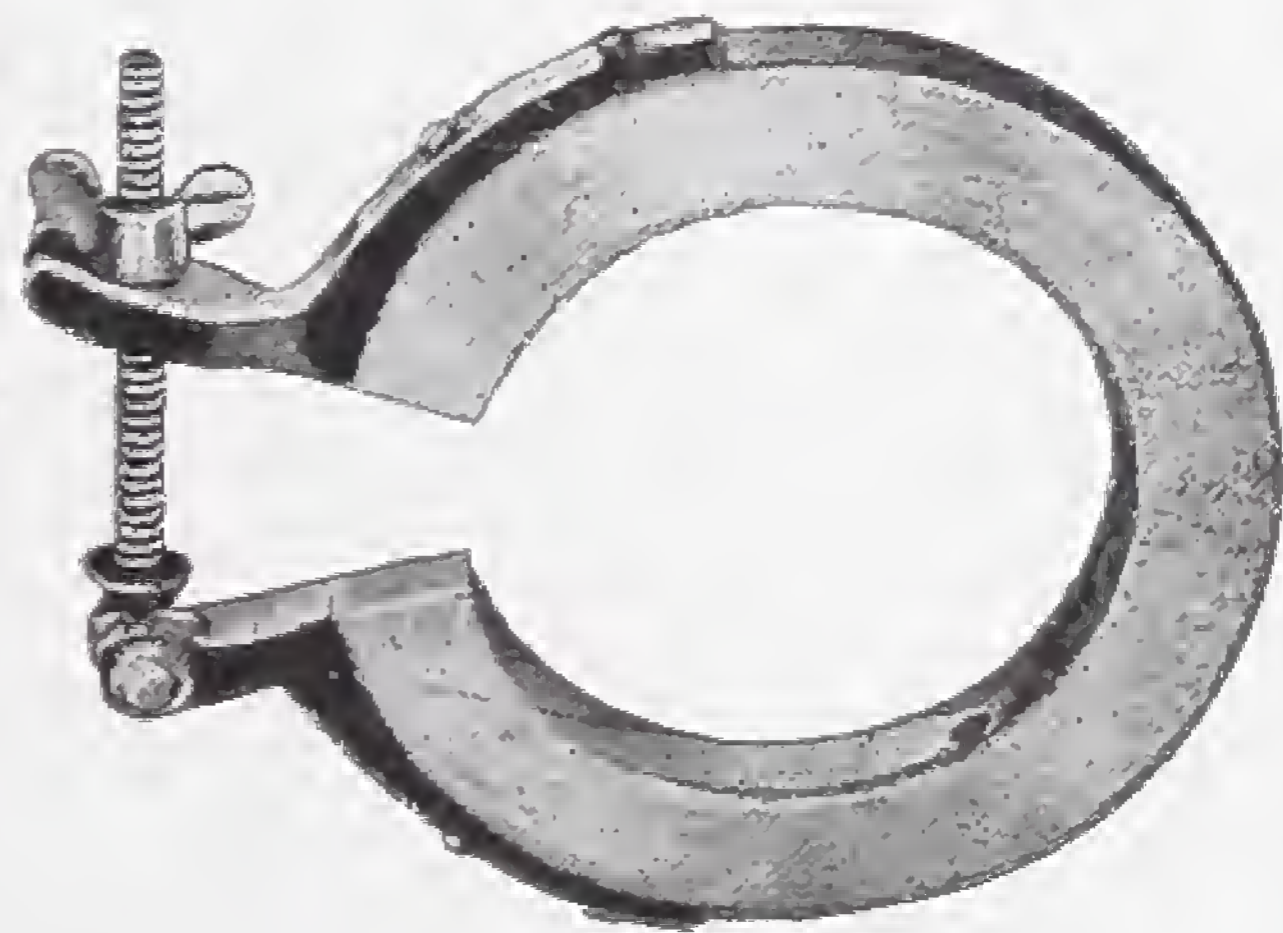

No. M 1916
**SQUIRREL TAIL
PIPE JOINTERS**

This adjustable jointing ring is used for pouring lead when caulking iron mains, soil pipe, etc. The rope is made from specially woven asbestos and fitted with a spring clip.

For pipes up to diam.: 3 in., 4 in., 6 in., 9 in., 12 in., 18 in., 24 in.





No. M 271

PLUMBERS' STOVE

For Coal or Coke. With Draught Cap, Poker, and 5 in. Metal Pot.

TOOLS

Plug 

Taper 

No. M23. GAS THREADING TAPS

STANDARD SIZE AND PITCH,
TAPER AND PLUG TAPS,
FOR IRON GAS TUBE

Sizes ...	$\frac{1}{8}$	$\frac{1}{4}$	$\frac{3}{8}$	$\frac{1}{2}$	$\frac{3}{4}$	1	$1\frac{1}{4}$	$1\frac{1}{2}$	$1\frac{3}{4}$	2 in.
-----------	---------------	---------------	---------------	---------------	---------------	---	----------------	----------------	----------------	-------

No. M 17. WHITWORTH
STANDARD SIZE AND PITCH,
TAPER, SECOND AND PLUG TAPS,
FOR BOLT PURPOSES

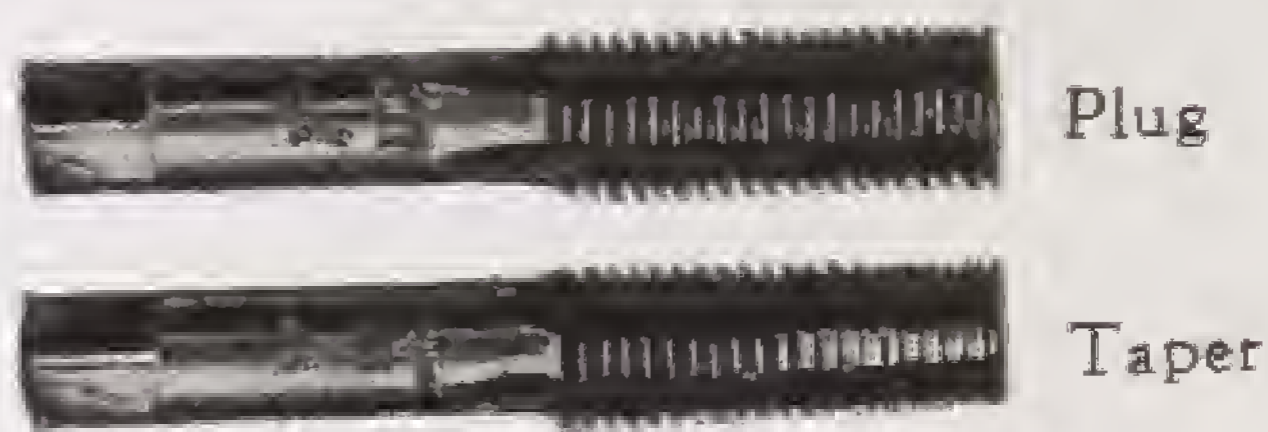

Sizes ... to	$\frac{1}{4}$	$\frac{5}{16}$	$\frac{3}{8}$	$\frac{7}{16}$	$\frac{1}{2}$	$\frac{9}{16}$	$\frac{5}{8}$	$\frac{3}{4}$	$\frac{7}{8}$	1 in.
--------------	---------------	----------------	---------------	----------------	---------------	----------------	---------------	---------------	---------------	-------



No. M 28
BURR REMOVING REAMER FOR BRACE

In cutting piping, particularly small sizes, there is left a bad burr, and as the full area of the pipe should be available this serviceable little reamer can work off easily the burring and leave a clean edge.

	A	B	BB	C
Pipe size ...	$\frac{1}{8}$ to $\frac{1}{2}$	$\frac{1}{8}$ to 1	$\frac{1}{4}$ to $1\frac{1}{4}$	$\frac{1}{4}$ to 2 in.

No. M 27
TAP WRENCH
ADJUSTABLE
Foreign.



No. ...	1	2	3	4	5
For Whit. ...	$\frac{1}{16} \times \frac{3}{8}$	$\frac{3}{16} \times \frac{1}{2}$	$\frac{1}{4} \times \frac{3}{4}$	$\frac{3}{8} \times 1$	$\frac{1}{2} \times 1\frac{1}{4}$ in. Tap
For Gas ...	—	$\frac{1}{4}$	$\frac{1}{2}$	$\frac{3}{4}$	1 in. Tap



No. M 210
ENGINEERS' STOCKS AND DIES
(Whitworth Thread)
Stocks and Dies.

Range Sizes : $\frac{1}{4}, \frac{3}{8}, \frac{1}{2}$ in. $\frac{1}{4}, \frac{5}{16}, \frac{3}{8}, \frac{7}{16}, \frac{1}{2}$ in. $\frac{1}{4}, \frac{5}{16}, \frac{3}{8}, \frac{7}{16}, \frac{1}{2}, \frac{5}{8}, \frac{3}{4}$ in. $\frac{1}{2}, \frac{5}{8}, \frac{3}{4}, \frac{7}{8}, 1$ in.

MIDGET RATCHET STOCK

FITTED WITH ADJUSTABLE SELF-LOCKING GUIDES
 For Gas, Conduit, Copper and Brass Threads. Guides cut away to give swarf clearance.
 An ideal Tool for use in awkward places.
 STOCK FRAME AND HANDLE IN ONE PIECE.

Set No.	Sizes
443/A	$\frac{1}{8}$ in., $\frac{1}{4}$ in., $\frac{3}{8}$ in., $\frac{1}{2}$ in. Gas
443/B	$\frac{1}{2}$ in., $\frac{3}{4}$ in., $\frac{1}{2}$ in. Conduit
443/C	$\frac{1}{4}$ in., $\frac{3}{8}$ in., $\frac{1}{2}$ in., $\frac{5}{8}$ in. Copper
443/D	$\frac{1}{8}$ in., $\frac{1}{4}$ in., $\frac{3}{8}$ in., $\frac{1}{2}$ in. Brass

All sets supplied in polished wood box. Combined Sets. Gas and Brass, etc., can be supplied as required.

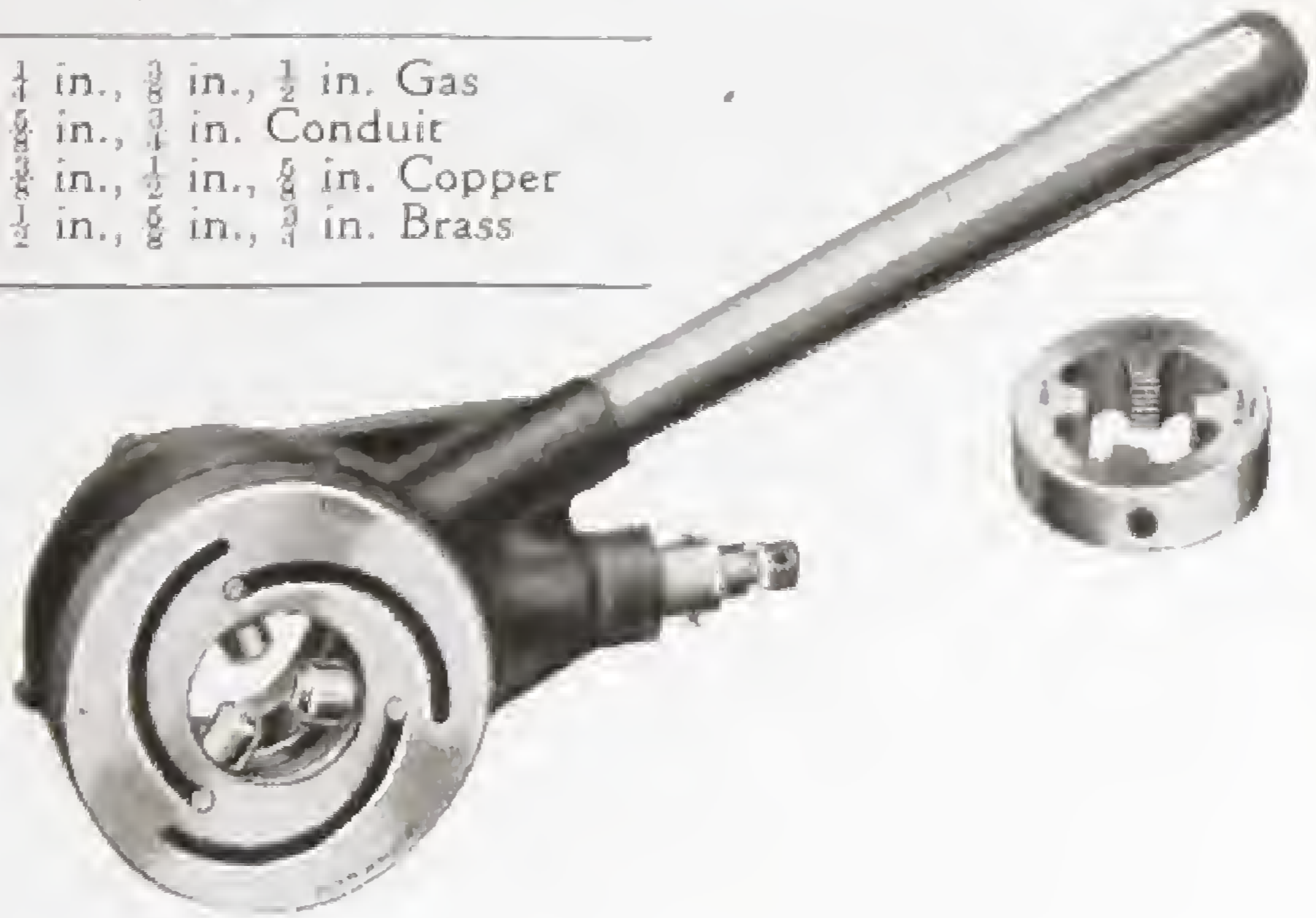

STOCKS AND DIES FOR BRASS OR COPPER TUBE

26 Threads per inch.

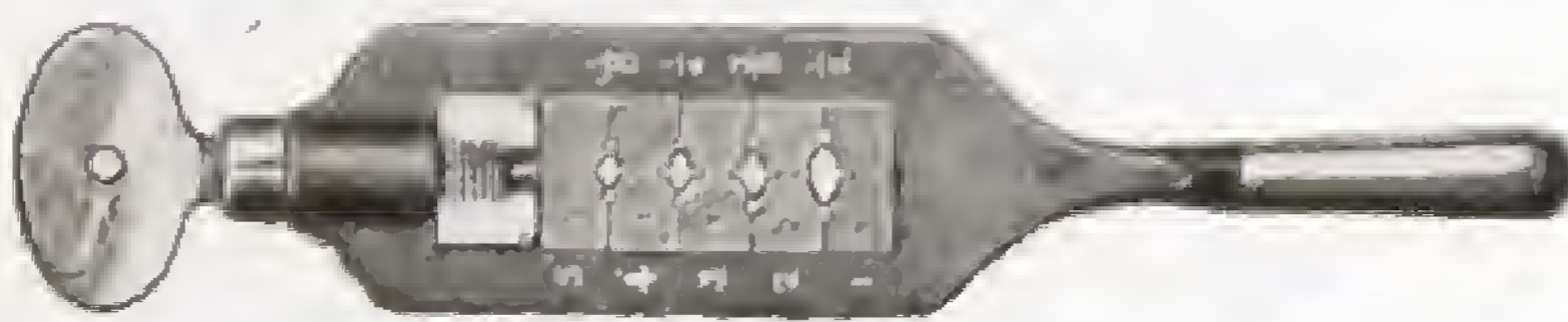

No. M 1206

	inches		
A	$\frac{1}{4}$	$\frac{3}{8}$	Brass
B	$\frac{3}{8}$	$\frac{1}{2}$	
C	$\frac{3}{8}$	$\frac{1}{2}$	
D	$\frac{1}{4}$	$\frac{3}{8}$	$\frac{1}{2}$
E	$\frac{1}{4}$ *	$\frac{3}{8}$	$\frac{1}{2}$
F	$\frac{1}{4}$ *	$\frac{3}{8}$	$\frac{5}{8}$
G	$\frac{1}{4}$ *	$\frac{3}{8}$	$\frac{3}{4}$
H	$\frac{1}{4}$	$\frac{3}{8}$	1

* Iron.

AMERICAN PATTERN GAS STOCKS AND DIES



No. M 1274

Light and portable, and possess exceptional strength. The Dies are adjustable to allow for variation in the pipes and can be re-sharpened, thus preserving the life of the tools considerably.

Sizes Cutting $\frac{1}{8}$, $\frac{1}{4}$, $\frac{3}{8}$, $\frac{1}{2}$ in. $\frac{1}{4}$, $\frac{3}{8}$, $\frac{1}{2}$, $\frac{3}{4}$, 1 in. $\frac{1}{2}$, $\frac{3}{4}$, 1 in. $1\frac{1}{4}$, $1\frac{1}{2}$, 2 in.
 In plain cardboard carton.

SCREWING TOOLS

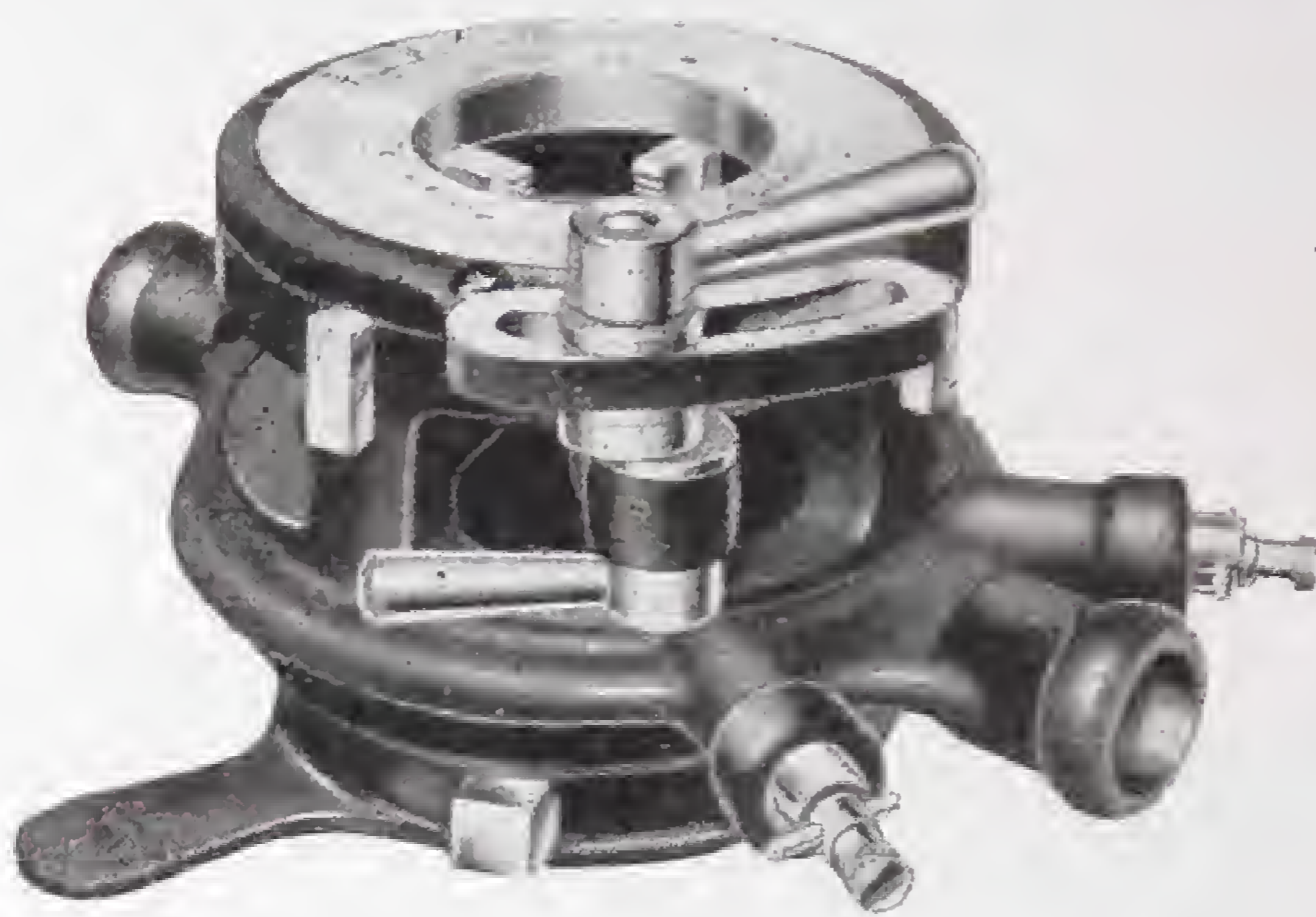

M 1271
CHASER
DIESTOCKS,
British Made
RATCHET PATTERN

No.	Screwing Sizes B.S.P.	Set of Dies
1R	$\frac{1}{4}$ in.— $1\frac{1}{4}$ in.	3
3R	$\frac{1}{2}$ in.—2 in.	3
4R	$1\frac{1}{2}$ in.—3 in.	2
6R	$2\frac{1}{4}$ in.—4 in.	2

No. 151
"MINOR" RATCHET PIPE DIE
STOCKS

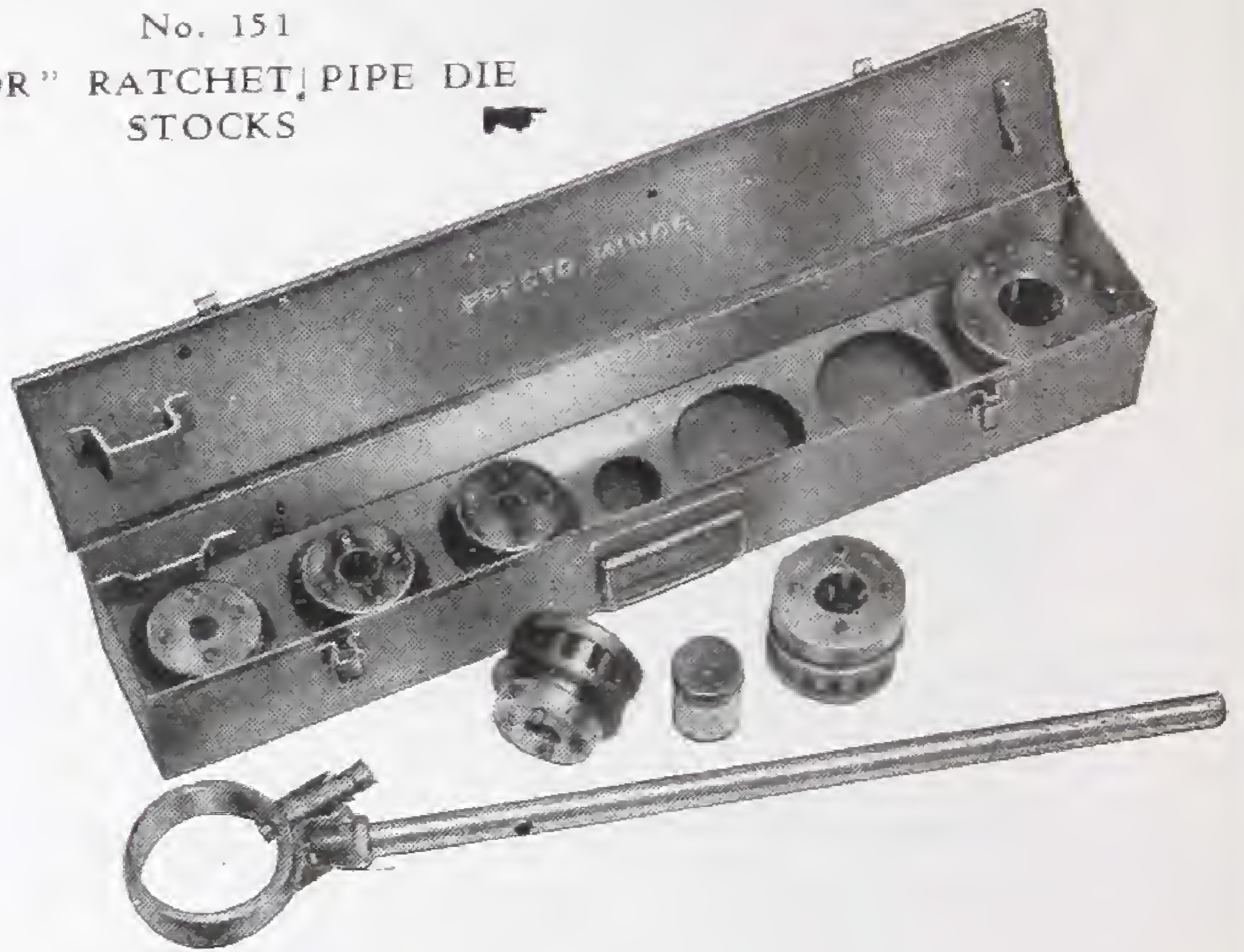

SET No.	1	2
Cutting Sizes ... in.	$\frac{1}{8}$ $\frac{1}{4}$ $\frac{3}{8}$ $\frac{1}{2}$ $\frac{5}{8}$ 1 $1\frac{1}{4}$ $1\frac{1}{2}$ 2 $2\frac{1}{2}$ 3	$\frac{1}{2}$ $\frac{3}{4}$ 1 $1\frac{1}{4}$ $1\frac{1}{2}$ 2 $2\frac{1}{2}$ 3 4

Description

No. of Part	Description
1	Ratchet Stock complete, except handle
2	Tubular Handle
3	Diehead Body $\frac{1}{8}$, $\frac{1}{4}$, $\frac{3}{8}$, $\frac{1}{2}$, $\frac{5}{8}$, 1, $1\frac{1}{4}$ in.
4	Diehead Cover $\frac{1}{8}$, $\frac{1}{4}$, $\frac{3}{8}$, $\frac{1}{2}$, $\frac{5}{8}$, 1, $1\frac{1}{4}$ in.
5	Screws for Diehead Cover (set of 4)
6	Ratchet Pawl
7	Ratchet Pawl Spring

SCREWING TOOLS

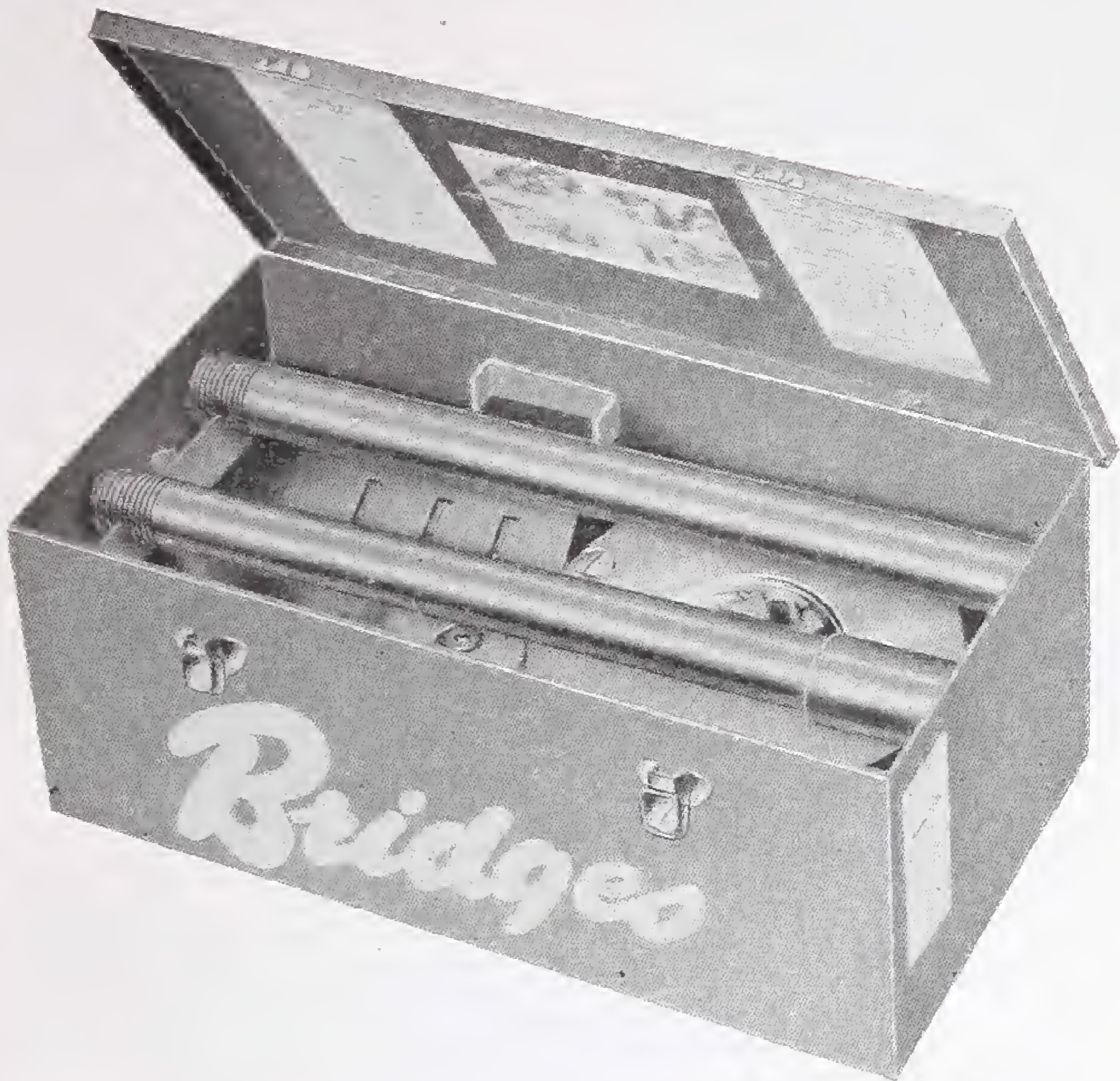

**ADJUSTABLE PIPE DIE
B.S.P.**

- | | | | |
|----|-----------------------------------|--|---------|
| 10 | ($\frac{1}{8}$ - $\frac{3}{8}$) | ($\frac{1}{2}$ - $\frac{5}{8}$) | (1 in.) |
| 13 | ($\frac{1}{2}$ - $\frac{5}{8}$) | (1 - $1\frac{1}{4}$ - $1\frac{1}{2}$ - $1\frac{3}{4}$ - 2 in.) | |

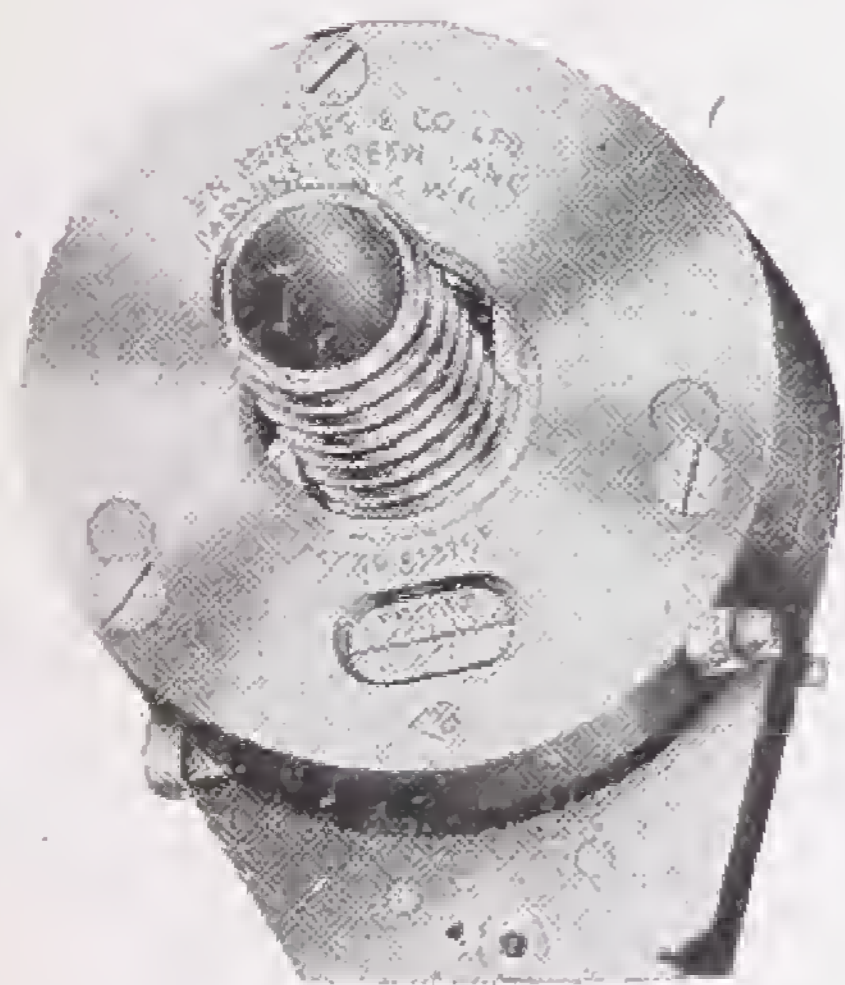

**RECEDER PIPE DIE
B.S.P.**

16AR (2 $\frac{1}{2}$ - 3 - 3 $\frac{1}{2}$ - 4 in.)



LIGHT ALLOY DIE-HEADS

Specially designed and produced for screwing alkathene, marleythene and similar polythene tubes . . .

Available in the following sizes :—
B.S.P. Thread $\frac{1}{2}$ in., $\frac{3}{4}$ in., 1 in.

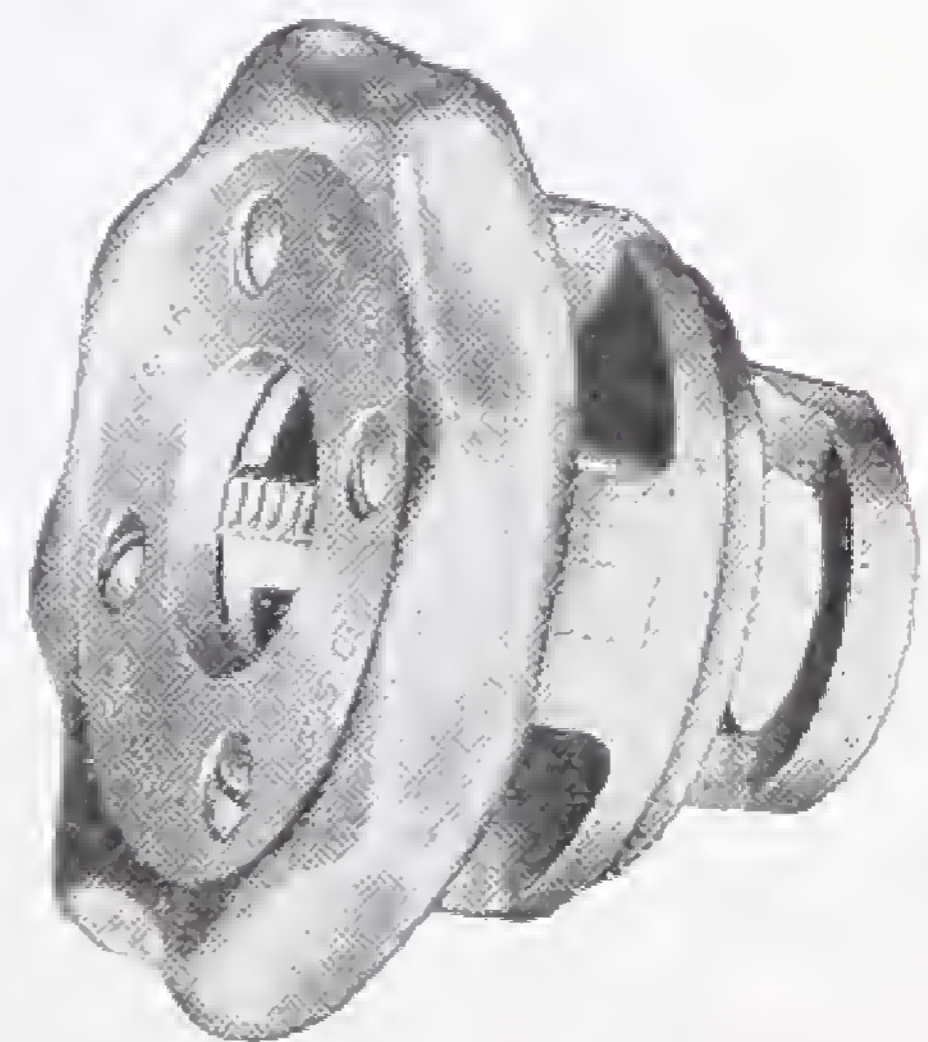

No. M 1915

UNIVERSAL "MASTER BENDERS" TYPES K.2 K.3 K.4

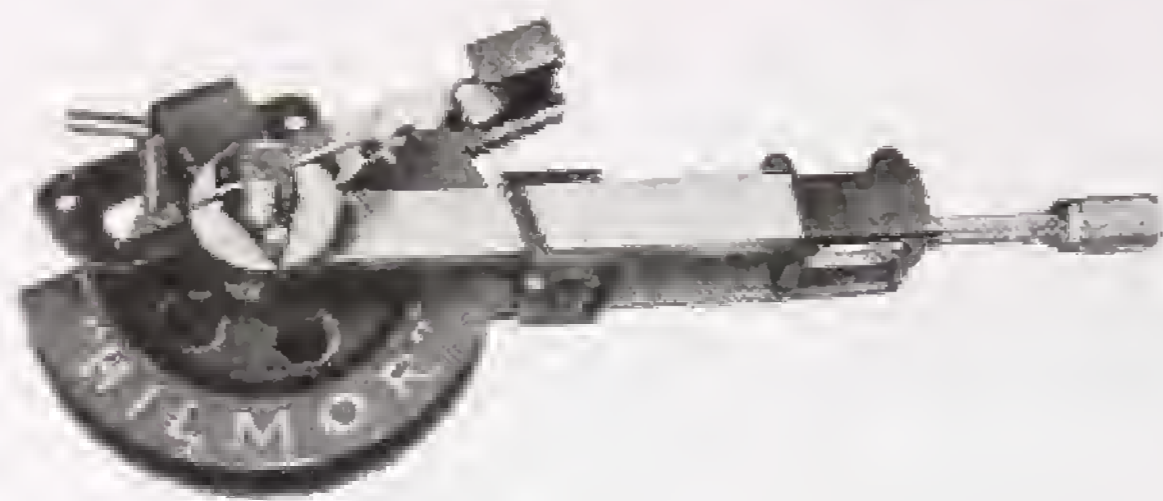

Type K.3 illustrated
Precision machines for the plumber
and general engineer, etc.

FEATURES

- Fitted with Pointer to determine degree of bend.
- Adaptable for bending tubes on standard or special radii.
- Pressure Indicator to determine correct position of Bending Lever.
- Designed to facilitate bending to accurate measurements.

CAPACITY

Type	Light gauge copper, aluminium, etc.	Light gauge steel, brass, etc.	Steel conduit
K.2	$\frac{1}{4}$ in. to 1 in.	$\frac{1}{2}$ in. to 1 in. O.D.	$\frac{1}{2}$ in. and $\frac{3}{4}$ in. O.D.
K.3	$\frac{1}{2}$ in. to 1 $\frac{1}{2}$ in.	$\frac{1}{2}$ in. to 1 $\frac{1}{4}$ in. O.D.	in. to 1 in. O.D.
K.4	$\frac{1}{2}$ in. to 2 in.	$\frac{1}{2}$ in. to 1 $\frac{1}{2}$ in. O.D.	in. to 1 $\frac{1}{4}$ in. O.D.

K type benders are precision built machines designed for the accurate bending of light gauge tube. They should not be used to bend heavy gas and steam tube.

PORTABLE BENDING OUTFITS

TYPES

GL.1A — GL.2 and GL.3A

The ORIGINAL portable benders designed for the Plumber and Gas Fitter (copper tube system).

FEATURES

- Completely portable outfits requiring no fixing or bolting down.
- Fitted with vice to hold tube for cutting off, fitting unions, etc.
- Constructed throughout in steel combining strength with lightness.
- Designed to facilitate the bending of long lengths of tube in rooms, corridors and other confined spaces.



Type GL.2

Type	CAPACITY
GL.1A	$\frac{1}{2}$ in. and $\frac{3}{4}$ in. light gauge copper tube
GL.2	$\frac{1}{2}$ in. to 1 in. " " " "
GL.3A	$\frac{1}{2}$ in. to 1 $\frac{1}{2}$ in. " " " "

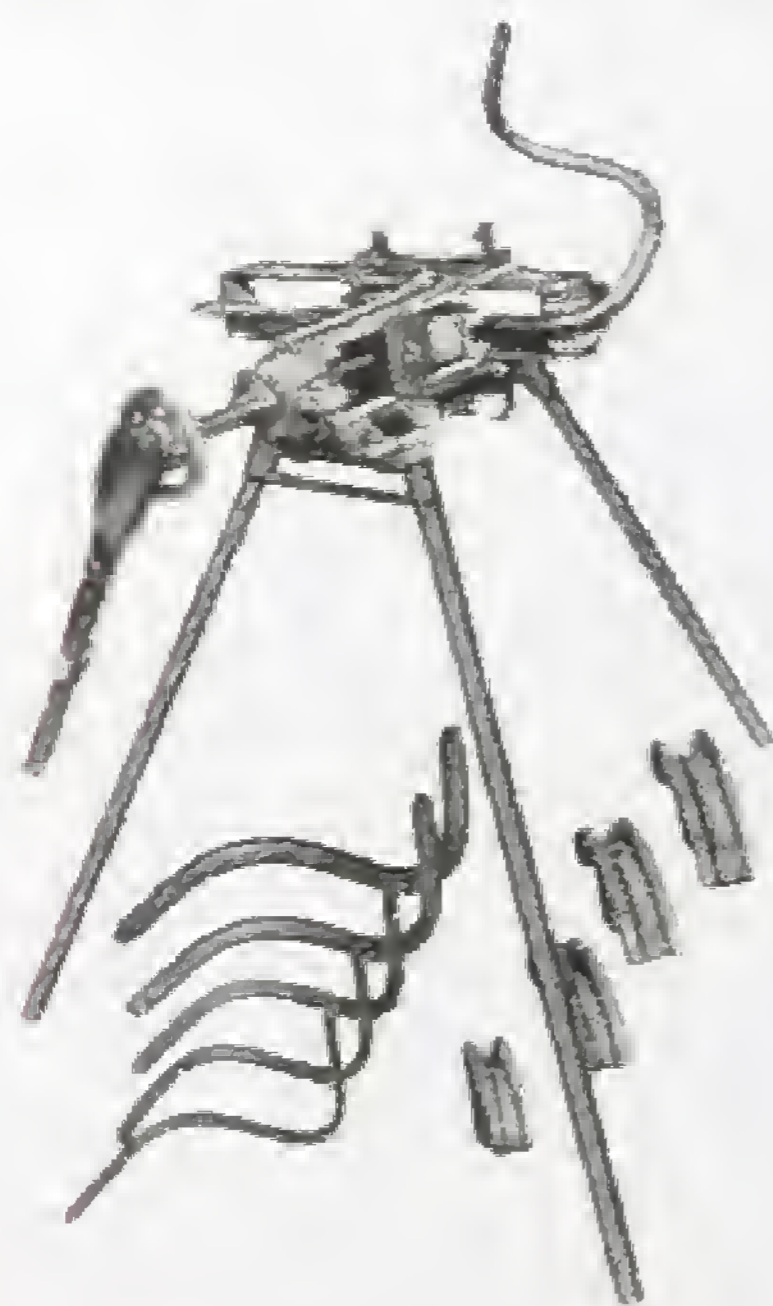

THE NEW "THREE POINT" BENDER No. 4 CAPACITY

GAS and STEAM	ELEC. CONDUIT
$\frac{1}{4}$ in. to 1 in. nom. bore (BSS 1387 class A, B and C)	$\frac{1}{2}$ in. to 1 $\frac{1}{2}$ in. O.D. (screwing size)

FEATURES

- The Adjustable Bending Head ensures that the correct degree of bending pressure is applied to all sizes and permits the production of a greater range of better quality bends than is obtainable on the conventional fixed head bender.
- The absence of top plate obstruction permits the production of compound bends in any plane with reduced straight between adjacent bends.
- The 90° bends can be made without distortion of screwed end in developed lengths of tube approximately 25 per cent. shorter than are required with fixed head benders.

No. M 1419

"BEANCO" LADDER BRACKET

(Pat. No. 671681)

FORGED STEEL BRACKETS

18 in. wide plank platform. 7 in. Toe Board. Adjustable Brackets for hand rail for Over and Under Ladder use. Recommended for Builders, Joiners, Plumbers, and other Tradesmen.



SCAFFOLD LASHINGS

No. M 1686A. MANILLA ROPE, Best $\frac{5}{8}$ in. diam. \times 18 ft.

No. M 1686B. WIRE, Best Steel, $\frac{1}{4}$ in. \times 12 ft. 15 ft. 18 ft.

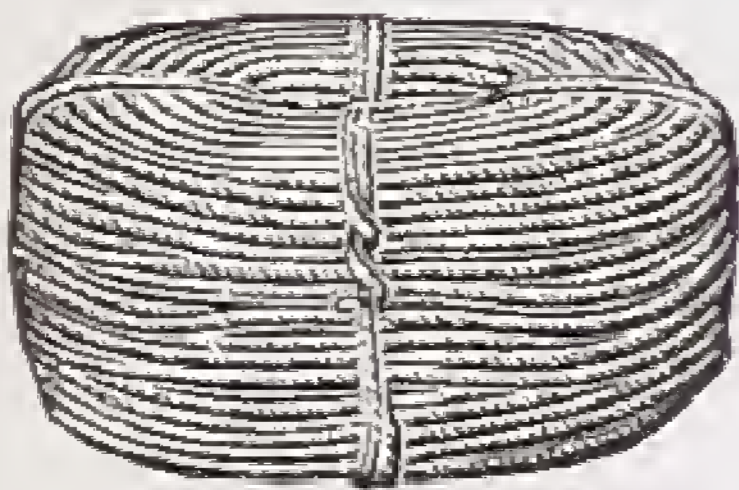

We shall be pleased to quote for—
**ROPES, BLOCKS, THIMBLES
SHACKLES, CLIPS, and all
LIFTING APPLIANCES.**

Manilla, Cotton, and Wire Ropes, Rope Clips, Thimbles, etc.

BEANCO IRON CEMENT

A cement in powder form—with a little water added to make up into a paste it is then applied for repairing leaks or breaks in castings or making good connections in steam or hydraulic work. The cement dries hard and withstands fire, water and steam, and is subject to the same conditions of expansion and contraction as cast-iron and offers an effective resistance to high pressures. 2 lb. and 14 lb. tins.

STEEL SHELVING

Steel Shelving is designed and produced essentially for the domestic market for use in the garage, workshop, storeroom, etc., and for light storage. Steel Shelving is available in many sizes. Dimensions of a single bay are from 71 in. high, 36 in. wide, 12 in. deep, with 6 shelves. Further bays may be added if needed. A Maximum Load of 150 lbs. per shelf if evenly distributed.

Particulars and Prices Quoted on Request.

1/4 in. HEAVY DUTY HOLGUN DRILL



The HOLGUN is a 1/4 in. drill of remarkable adaptability and design. Its compact size and handy shape enables the operator to approach many of those difficult drilling spots with ease and convenience. De-

signed with abundant power for continuous use and to give long and trouble-free service. Particularly suitable for aircraft production and the lighter industries. The reduced spindle speed and increased torque of the Low Speed Model makes it the perfect 1/4 in. Drill for production work in monel metal and other modern hard alloys.

	Standard Holgun	Low Speed Model
Drilling capacity in Steel	1/4 in.	1/4 in.
" " " " " Hardwood	1/2 in.	1/2 in.
Standard Spindle Speed (No-load) R.P.M.	1,700	600
Weight	3 1/2 lbs.	3 1/2 lbs.
Overall Length (in direction of spindle)	7 1/4 in.	7 5/8 in.
Spindle Offset	3/4 in.	3/4 in.
Input Watts	300	300

5/16 in. HEAVY-DUTY AND 3/8 in. STANDARD DRILLS

Designed for general purpose drilling of all kinds; ruggedly constructed with ample power. Splined gear mounting, with spindle locked in housing and needle roller bearings on chuck spindle. Short, compact and well balanced, with comparatively low speed and high torque.

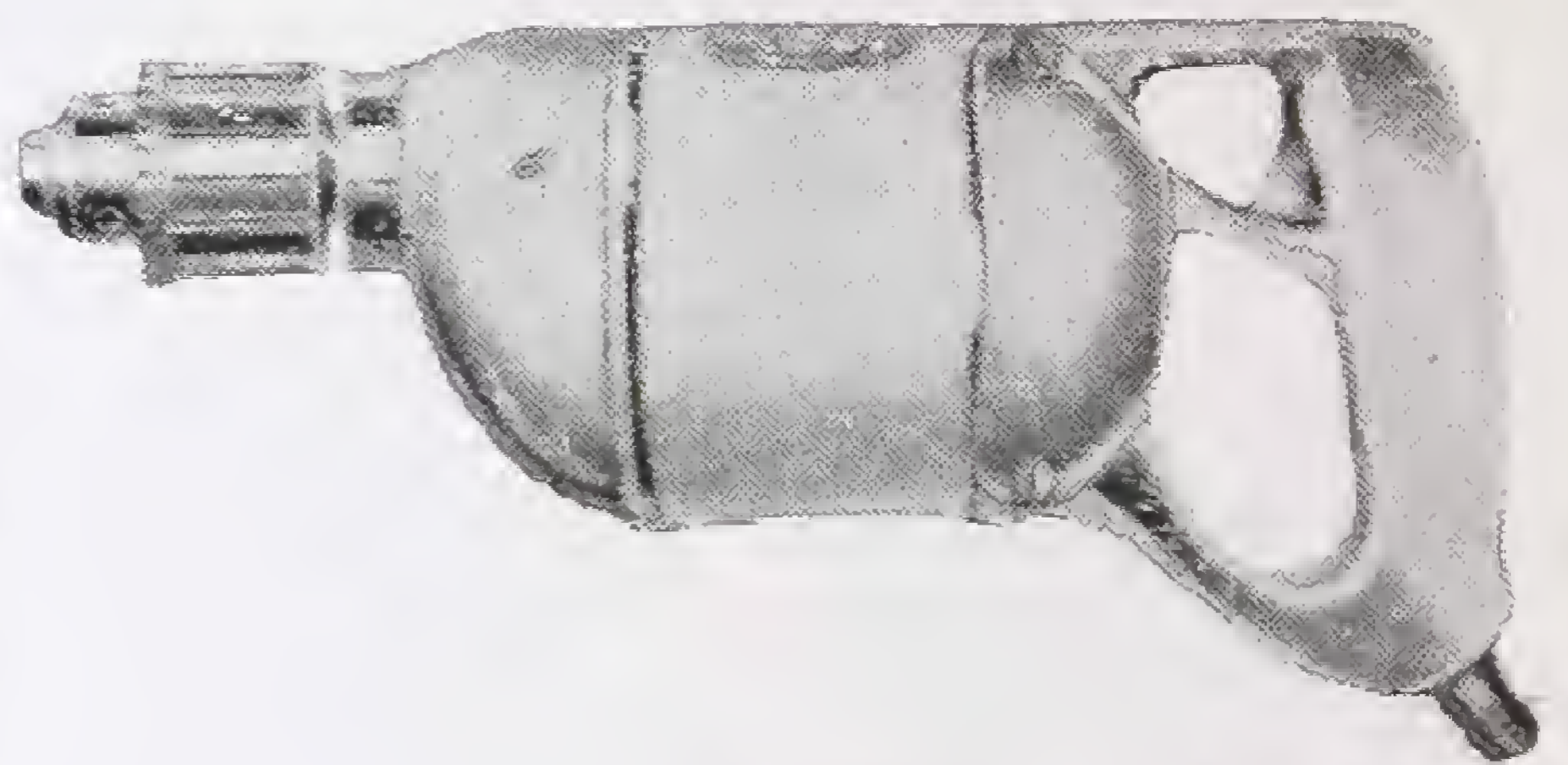

	5/16 in. Heavy-duty Drill	3/8 in. Standard Drill
Drilling capacity in Steel	5/16 in.	3/8 in.
" " " " " Hardwood	5/8 in.	3/4 in.
No-load Speed (R.P.M.)	1,400	900
Weight	7 lbs.	7 1/2 lbs.
Overall Length	12 3/8 in.	12 1/2 in.
Input Watts	330	330

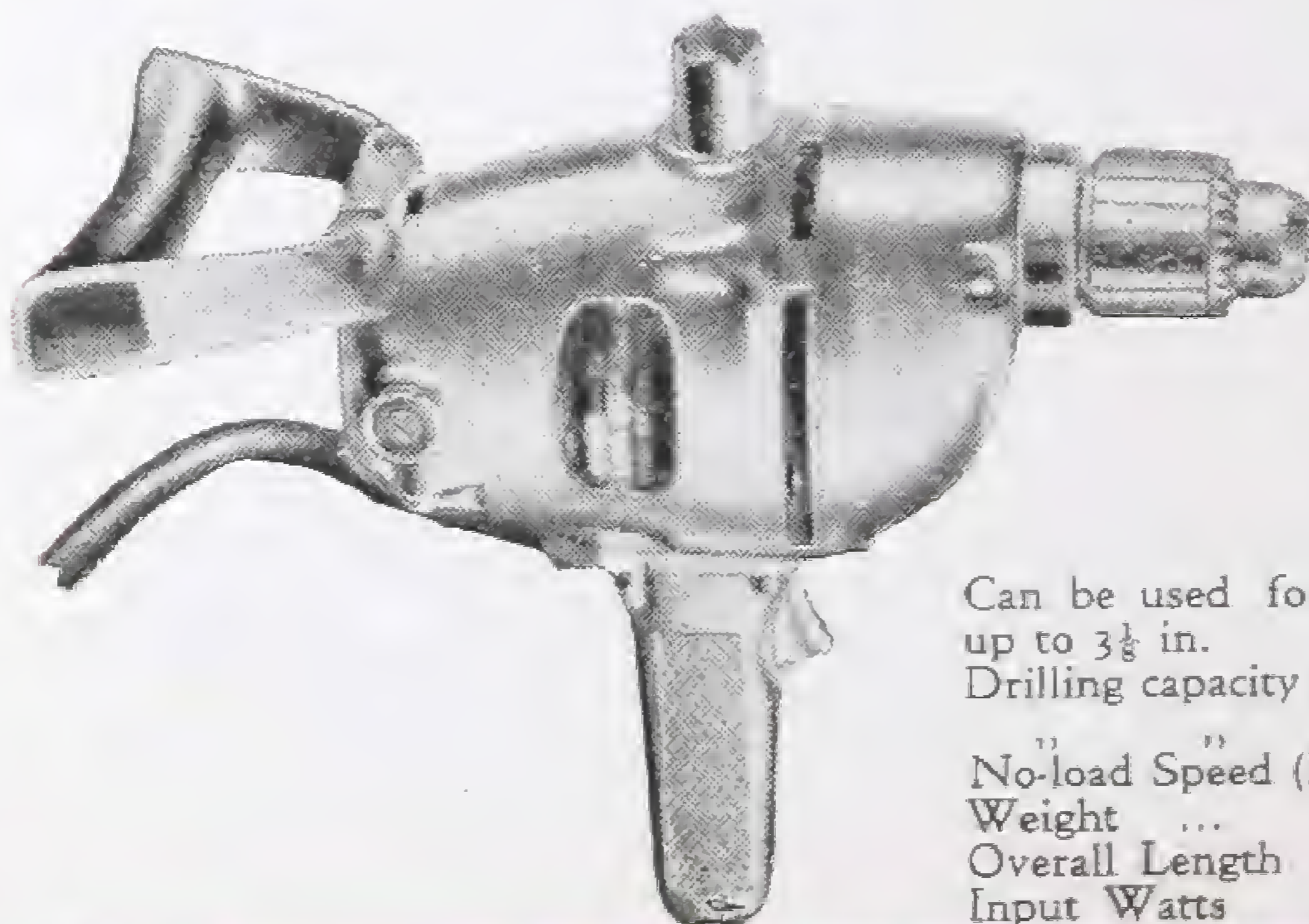

1/2 in. STANDARD DRILL

A short compact and ruggedly constructed 1/2 in. drill with plenty of power, comparatively low speed, high torque, minimum spindle offset, perfect operating balance, fitted with horizontal spade handle for ease of handling.

Can be used for cutting with hole saws up to 3 1/2 in.

Drilling capacity in Steel	1/2 in.
" " " " " Hardwood	1 in.
No-load Speed (R.P.M.)	400
Weight	10 3/4 lbs.
Overall Length	13 3/4 in.
Input Watts	375

6 in. STANDARD BENCH GRINDER

This compact handy little tool is fitted with removable wheel guards that, while protecting the operator, are wide enough to permit the use of wire wheel brushes. The Standard Bench Grinder has a carefully balanced rotor and spindle mounted on full-sized ball bearings with special protective sleeves for keeping out abrasive dust and dirt. Ideal for tool sharpening, general grinding, wire brushing, buffing, etc. Can be supplied with either single-phase or three-phase motor.

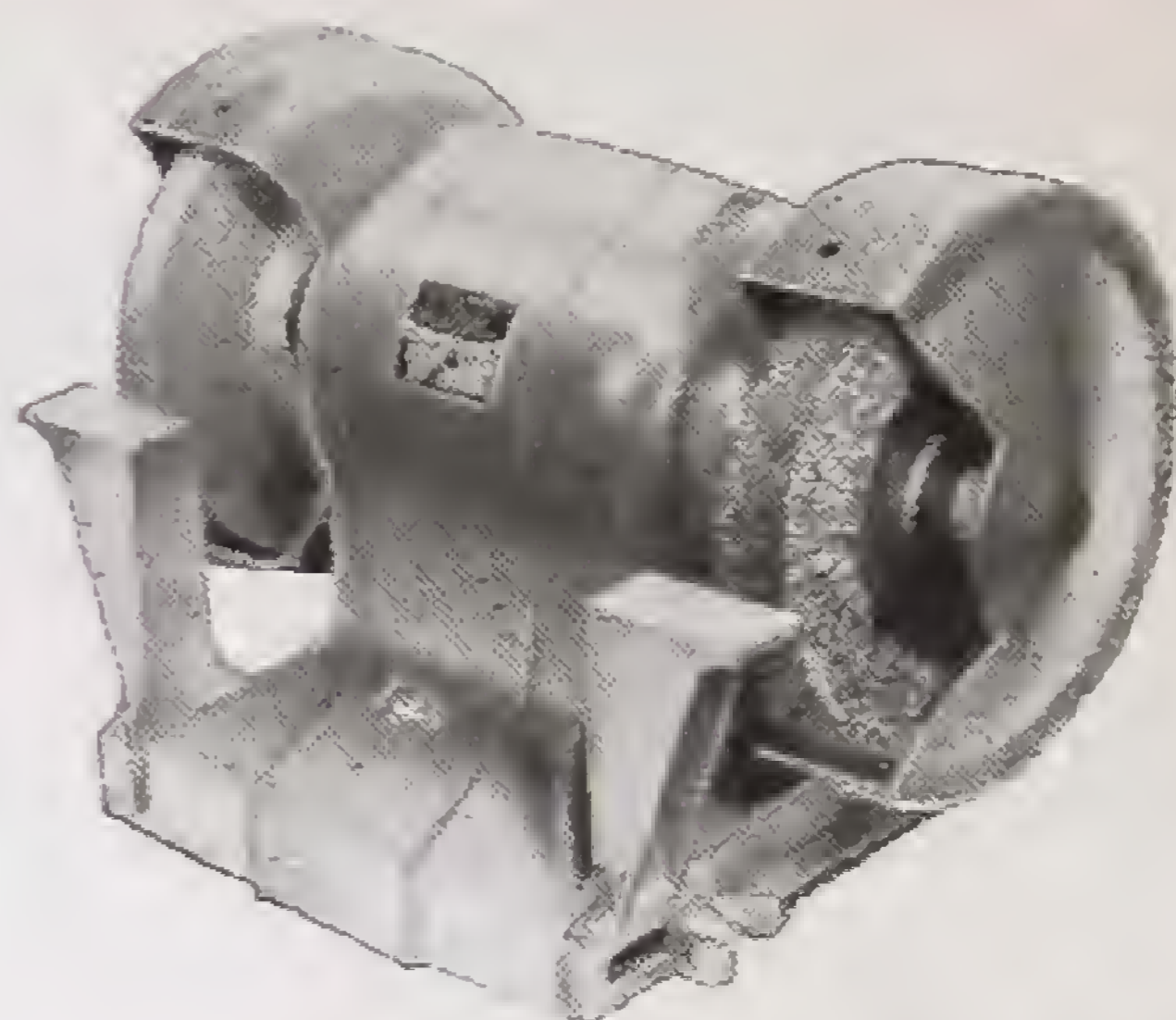

Wheel size	...	6 in. diam. × 5/8 in. face × 1/2 in. hole
Motor (not available for D.C.)	... 115, 125, 220, 240 volts, 50-60 cycles, single-phase A.C.	220 or 440 volts, 50-60 cycles, three-phase A.C.
Motor Rating	...	1/4 h.p.
No-load Speed (R.P.M.)	...	50 cycles—3,000
Weight	...	25 lbs.
Overall Spindle Length	...	11 3/4 in.
Overall Height	...	9 3/8 in.
Input Watts	...	280



5 in. PORTABLE GRINDER

Wheel Size	...	5 in. × 3/4 in. × 1/2 in.
No-load Speed (R.P.M.)	...	4,500 and 6,200
Weight	...	13 lbs.
Overall Length	...	22 1/2 in.
Input Watts	...	720

8 in. AND 9 in. HEAVY-DUTY ELECTRIC SAWS

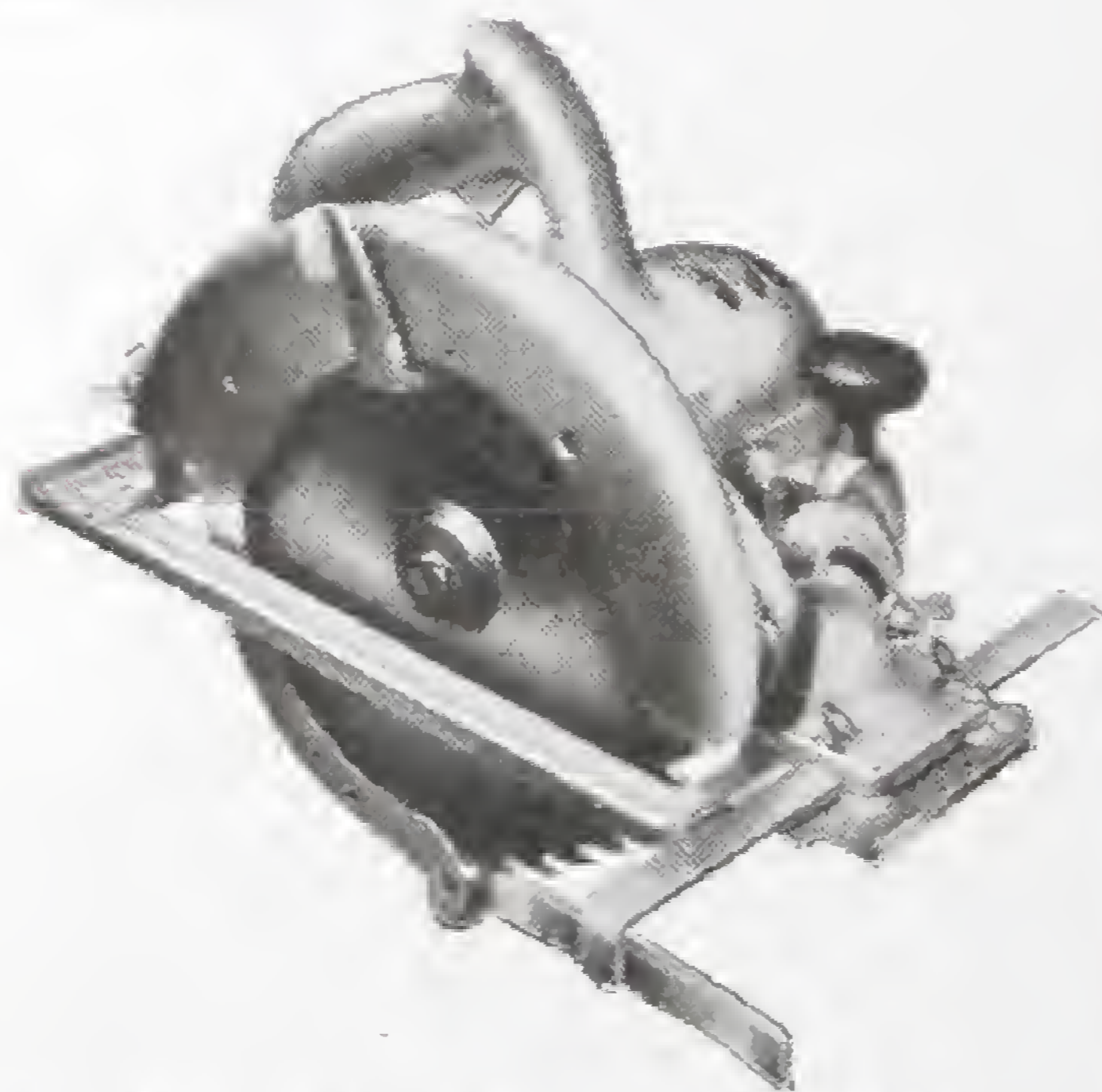

Black & Decker Electric Saws are the final word in Portable Circular Saws. Ten times faster than a well-sharpened hand saw in wood, they can be adapted by changing the blade to cut brick, tile, cement, asbestos, cast-iron guttering, fall pipes, earthenware drains, stone, plastics, and a wide variety of composition materials. Black & Decker Saws are adjustable for any depth of cut up to given maximum and for angle cuts from 0° - 45°.

The 8 in. and 9 in. models are high-speed "one-hand" saws having helical gears which are grease lubricated. This eliminates oil-spill and enables the saw to be inverted and used as a saw-bench.

Specifications	8 in. Saw	9 in. Saw	Specifications	8-in. Saw	9 in. Saw
Blade Diameter	8 1/4 in.	9 1/4 in.	Speed (R.P.M.)	4,500	3,700
Maximum Depth of Vertical cut	2 1/8 in.	3 1/4 in.	Overall length	14 1/8 in.	14 1/2 in.
Maximum Depth of 45° cut	2 1/8 in.	2 5/8 in.	Overall height	11 in.	11 3/8 in.
			Overall width	9 3/8 in.	9 1/2 in.
			Weight	14 1/4 lbs.	15 3/4 lbs.
			Input Watts	1065	1065

6 in. HEAVY-DUTY ELECTRIC SAW

This light-weight saw has been designed for a variety of purposes in addition to carpentry, it has power, stamina and durability seldom found in a tool of this low price. As in the larger saws the telescoping lower blade guard closes automatically as the saw is lifted off the work, providing complete safety to the operator.

Specifications

Blade diameter 6½ in. Depth of cut 2½ in. Net weight 9½ lbs. No-load speed 3,500 r.p.m.

Height 9½ in. Width 8½ in. Length 9½ in.

Standard Equipment

25 ft. 3-core cable, 2-pole instant release trigger switch, Combination Blade for rip and cross-cutting.



THE 7 in. H.D. SANDER-GRINDER



do the kind of work you want. The 7 in. H.D. Sander-Grinder can be adapted for use with 7 in. and 9 in. sanding discs, coarse grinding wheels, wire cup brushes or planer heads. The higher speed models are specially designed for use with the 7 in. or 9 in. depressed centre "cut-off" wheel which stabilizes the grinding wheel for many types of grinding jobs. Designed for trouble-free service, the wheels and bearings are sealed against dirt and dust.

This newly designed Sander-Grinder is lighter, 50 per cent more powerful than previous models and has the abundant power necessary for continuous heavy duty production work. You choose one of three spindle speeds to

Spindle	7 in. diam. 1/2 thread
Overall Length (no pad)	14½ in.
Net Weight	14 lbs.
Shipping Weight	17½ lbs.
Spindle speeds	4,200, 5,200 and 6,000 r.p.m.
Rated input Watts	100

Standard equipment includes three-core cable (3000 size for portability), 1 Medium Sanding Disc, No. 13489 5 in. moulded rubber pad, No. 11000 6½ in. Enclite backing pad, Clamp washer, Movable side handle, No. 22411 Stand, Square wrench.



With Wire Cup Brush
4,200 and 5,200 R.P.M.*



With Depressed Centre Disc
5,200 and 6,000 R.P.M.*



With Coarse Grinding Wheel
4,200 and 5,200 R.P.M.*



With Planer Head
4,200 R.P.M.*

* Recommended Speeds

TOOLS

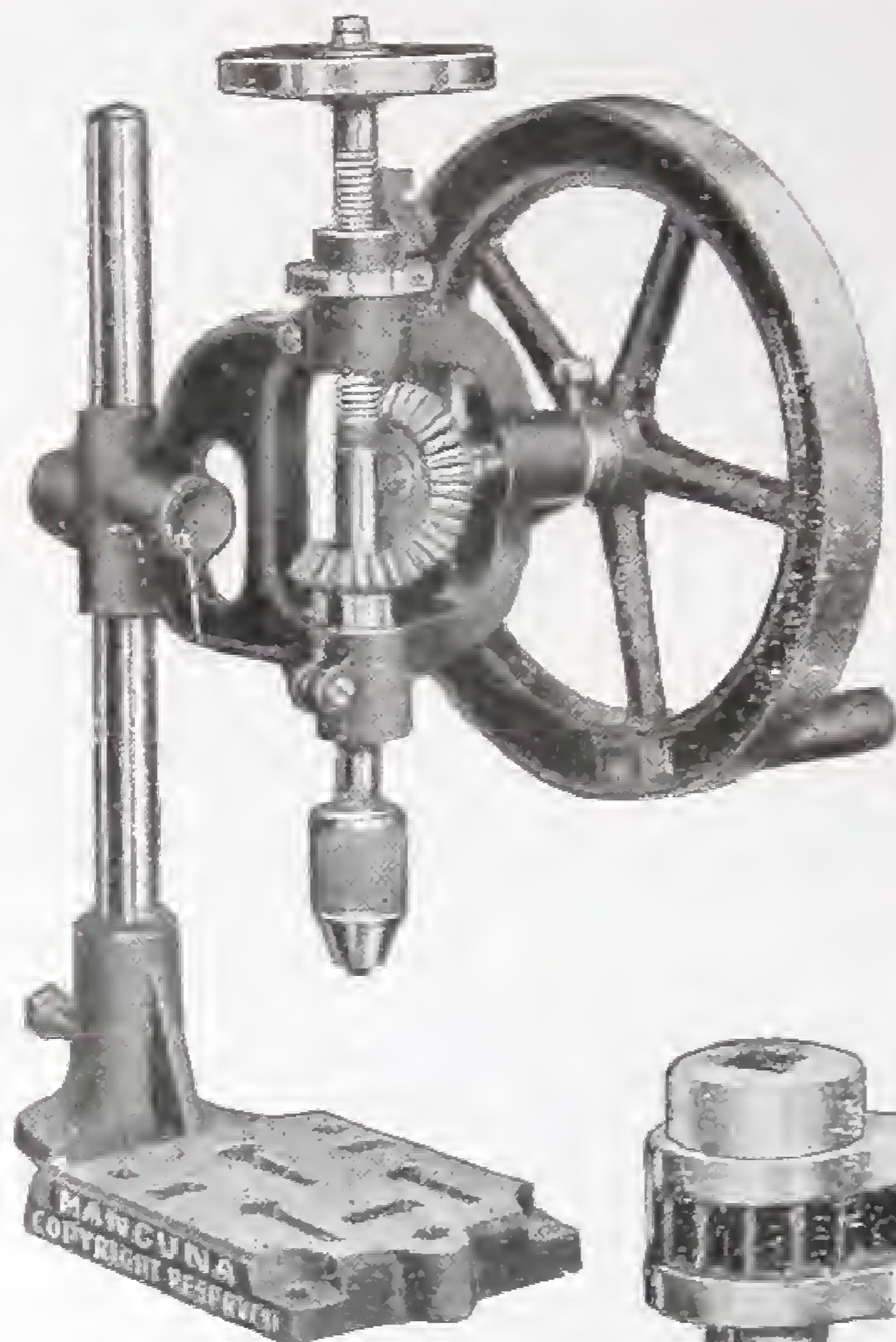

No. M 1530
BENCH AND WALL
HANDPOWER
DRILLING MACHINE

With automatic feed ; steel gears
and adjustable chuck, taking round
shank drills $0-\frac{1}{2}$ in.

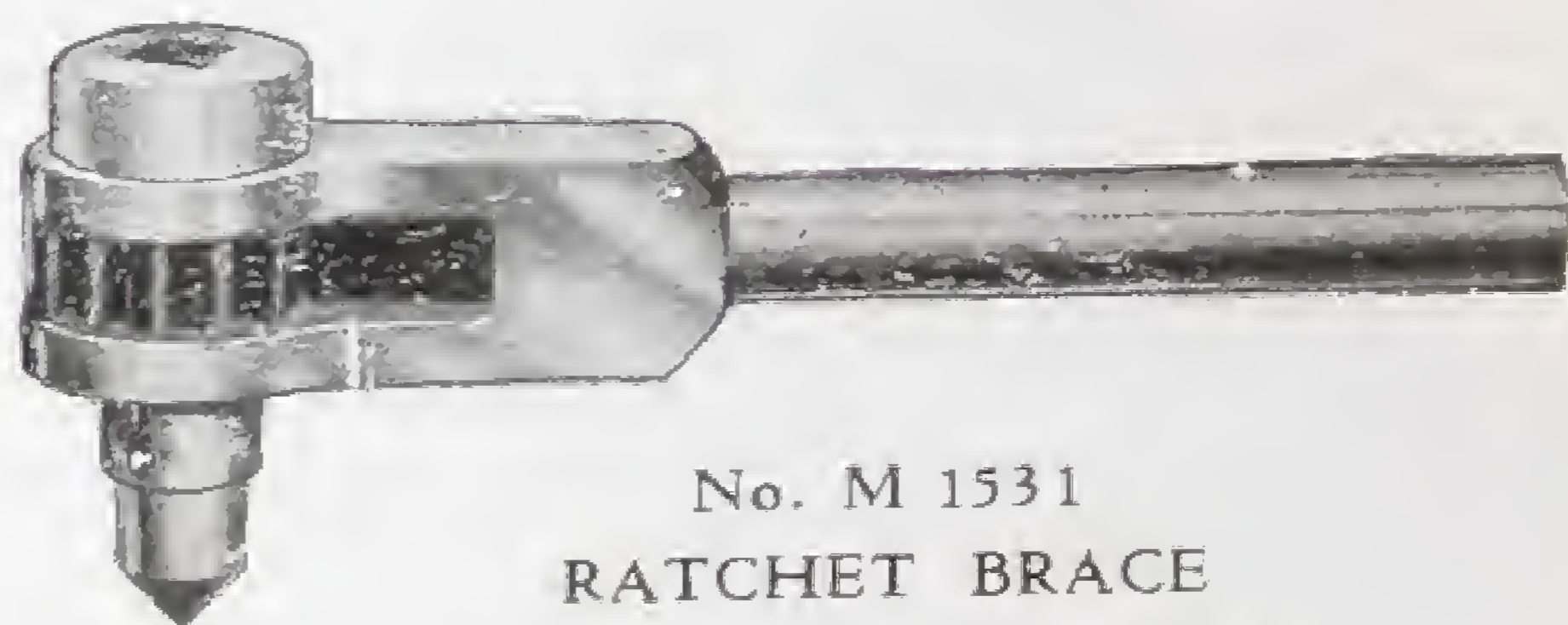

No. M 1531
RATCHET BRACE

Lengths : 12, 14, 16, 18 in.

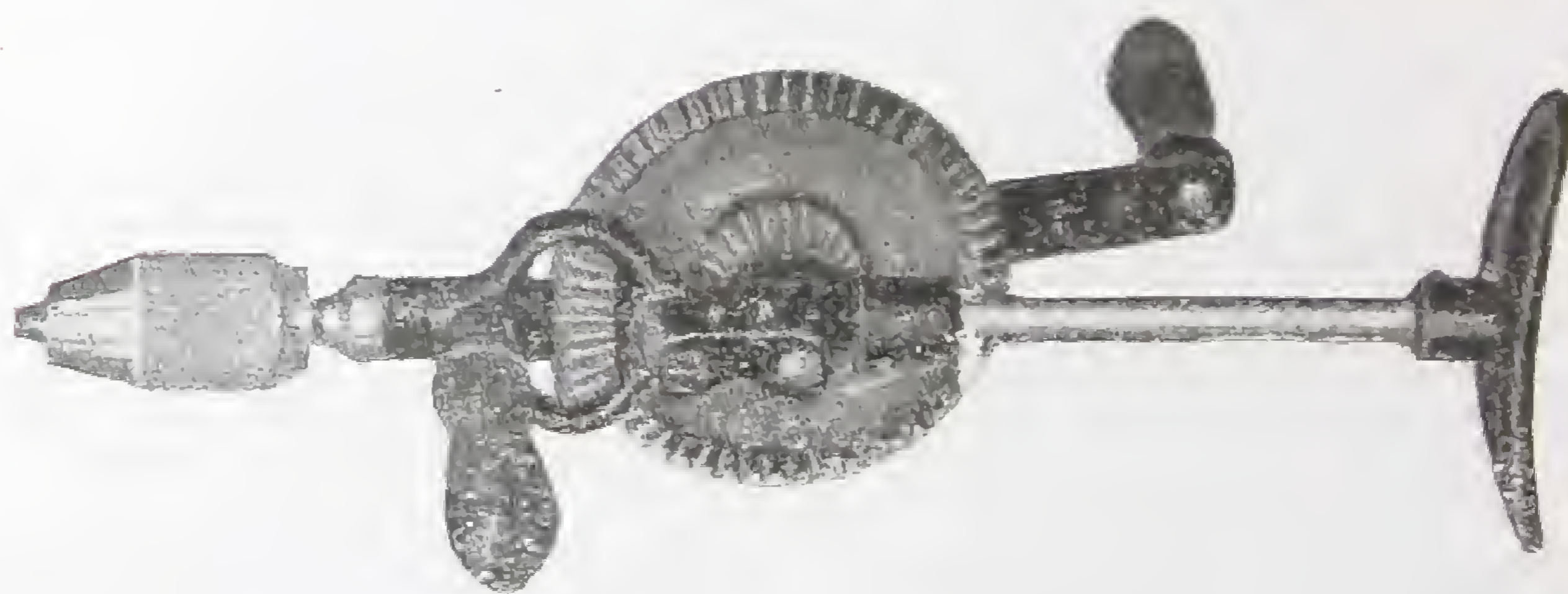

No. M 1511A. BREAST DRILL

Three-jaw all-steel Chuck with hardened jaws and protected springs. Nickel-plated Finish. Two speed.

Cast-iron body. Steel shank. Ball-thrust bearing. Adjustable breast plate. Crank handle extensible from 4 in. to 6 in. radius.

Capacity $0-\frac{1}{2}$ in. round shanks. Length 17 in. Weight $5\frac{1}{2}$ lbs.

Stanley No. 905.

ENGINEERS' TWIST DRILLS
All Sizes and Types Stocked.

No. M 1917

$\frac{1}{64}$ in. — $\frac{1}{2}$ in.

No. 2 Set ... $\frac{1}{16}$, $\frac{3}{32}$, $\frac{1}{8}$, $\frac{5}{32}$, $\frac{3}{16}$, $\frac{7}{32}$, $\frac{1}{4}$ in.

No. 4 Set ... $\frac{1}{16}$, $\frac{1}{8}$, $\frac{3}{16}$, $\frac{1}{4}$, $\frac{5}{16}$, $\frac{3}{8}$ in.

No. 5 Set ... $\frac{1}{16}$, $\frac{1}{8}$, $\frac{3}{16}$, $\frac{1}{4}$, $\frac{5}{16}$, $\frac{3}{8}$, $\frac{7}{16}$, $\frac{1}{2}$ in.



No. M 1918
CASED SETS

$\frac{1}{16}$ in. — $\frac{1}{4} \times \frac{1}{64}$ in.

or

$\frac{9}{32}$ in. — $\frac{1}{2}$ in. $\times \frac{1}{32}$ in.

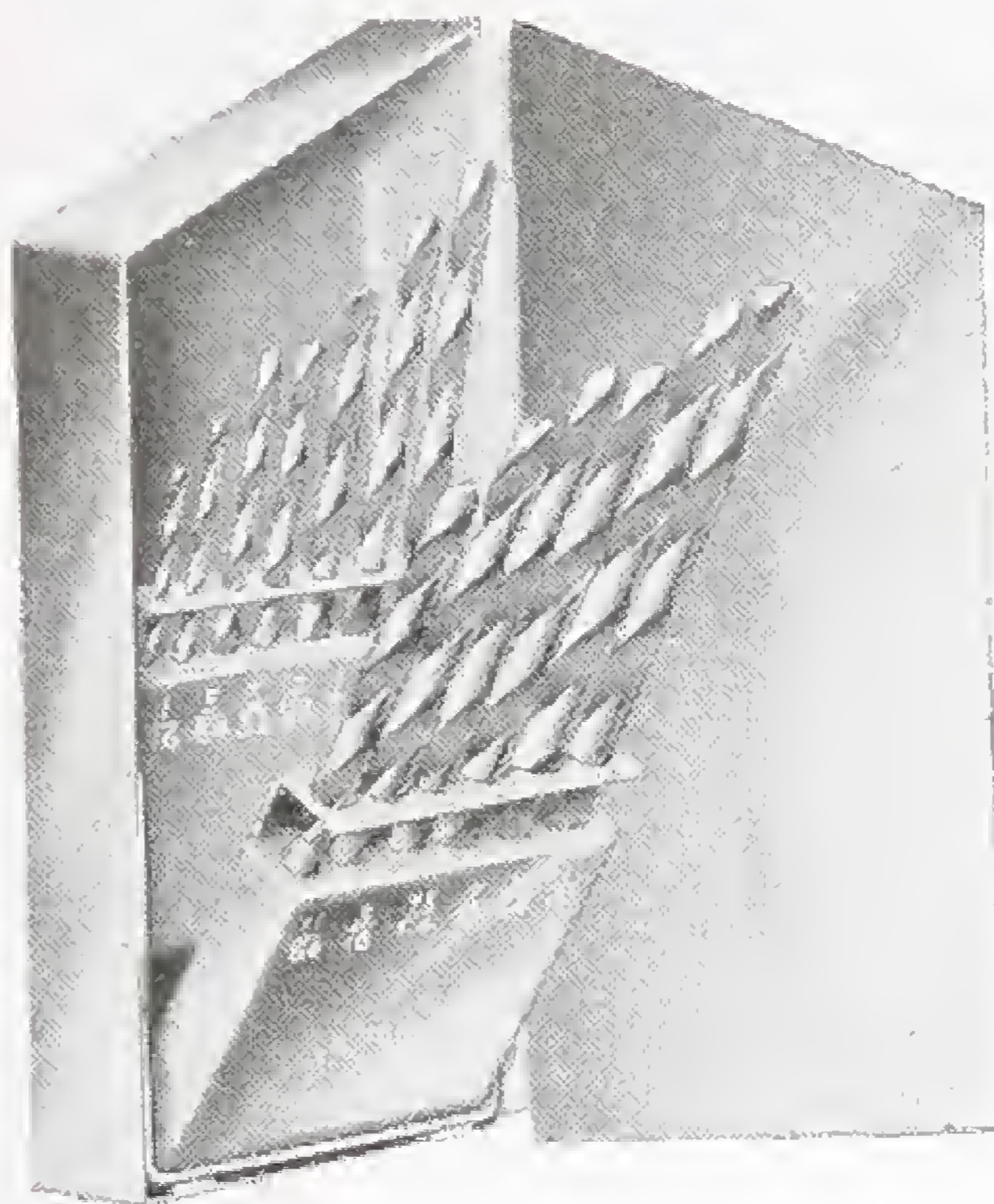

No. M 1292
ENGINEERS' RATCHET DRILLS

Shank : $\frac{3}{4}$ in. $\times \frac{1}{2}$ in. $\times 1\frac{3}{4}$ in. long.

Stock Sizes :

$\frac{1}{8}$ in. up to $1\frac{1}{2}$ in.



No. M 1919

WOODWORKING DRILLS

With $\frac{1}{4}$ in. Shanks.

$\frac{1}{4}$ in., $\frac{5}{16}$ in., $\frac{3}{8}$ in., $\frac{7}{16}$ in., $\frac{1}{2}$ in.

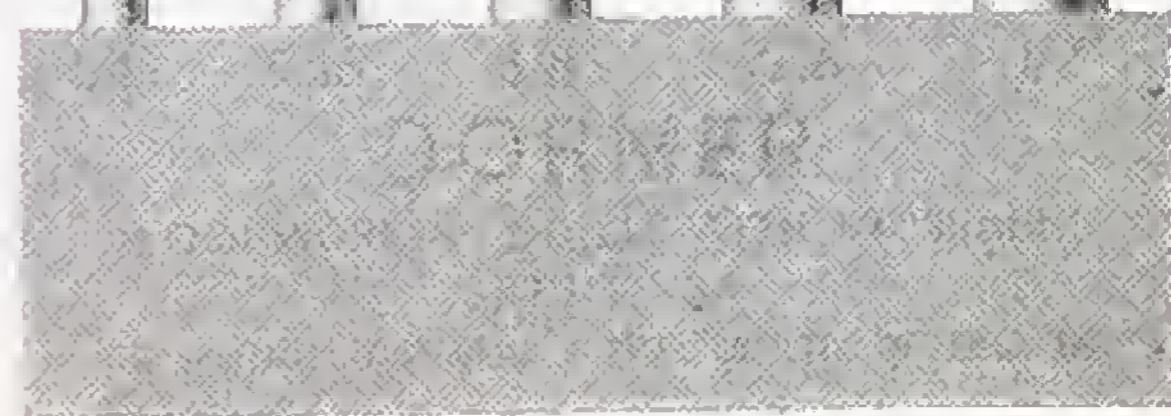

TOOLS

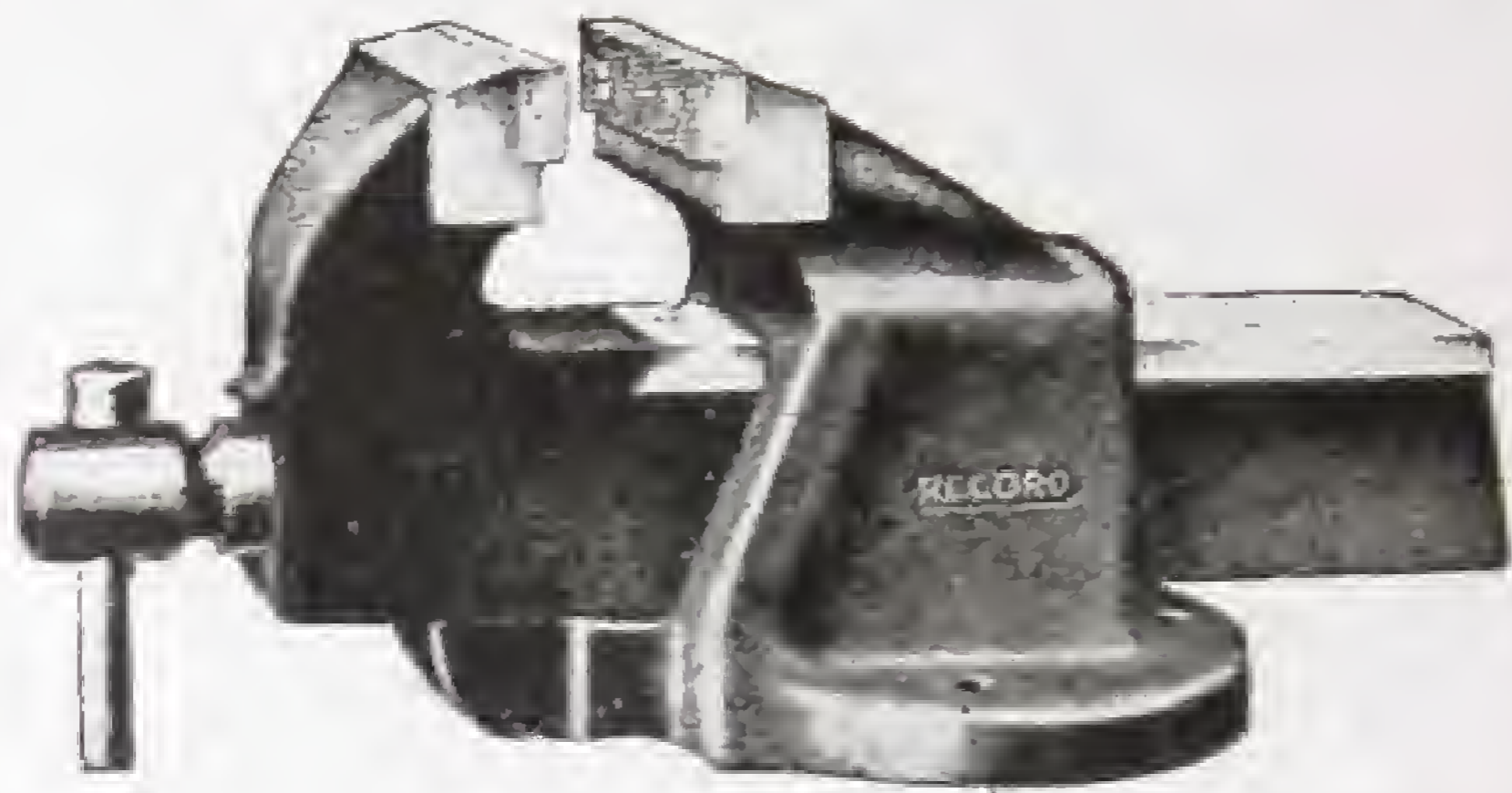

No. M 186

MECHANICS' VICE

Stationary Base

Plain Screw Type.

Specification Approximate

Size No.	0	1	2	3	4	5	6	7
Width of Jaws	2½	3	3½	4	4½	5	6	7 in.
Maximum Opening	2½	3½	4	4¾	5½	6½	8	9 "
Depth of Jaws	1½	1¾	2¾	2¾	3	3½	3½	4 "

Quick-grip Pattern also supplied.

No. M 1629.
WOODWORKERS' VICE

With Steel Slides
Perfect Sliding Movement
Firm Grip.
No Side Slipping.
Great Strength.

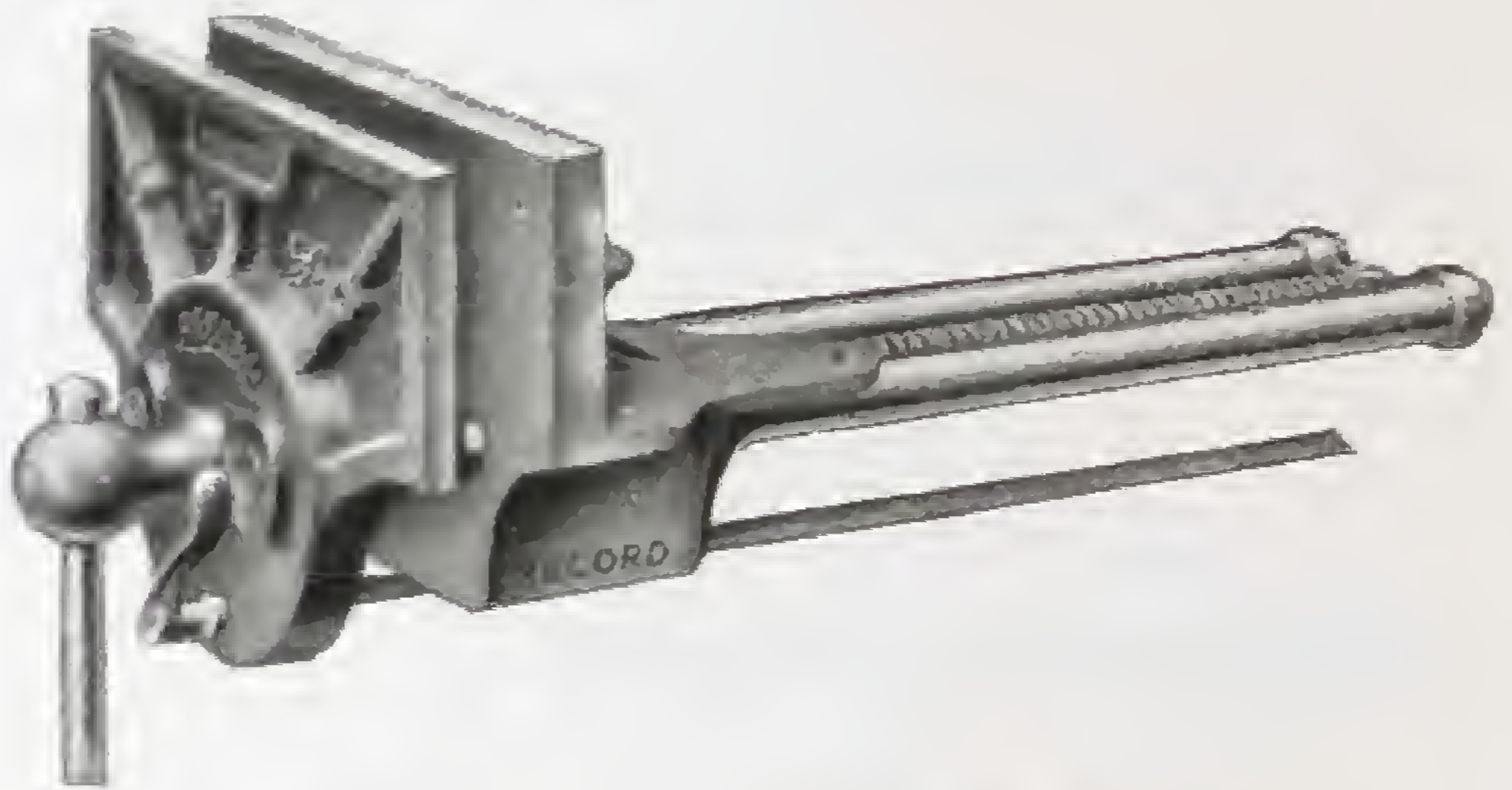

Width Jaws Inches	Max. Opening Inches	Approx. Weight lbs.
7	8	16
9	12	30
10½	12¾	32

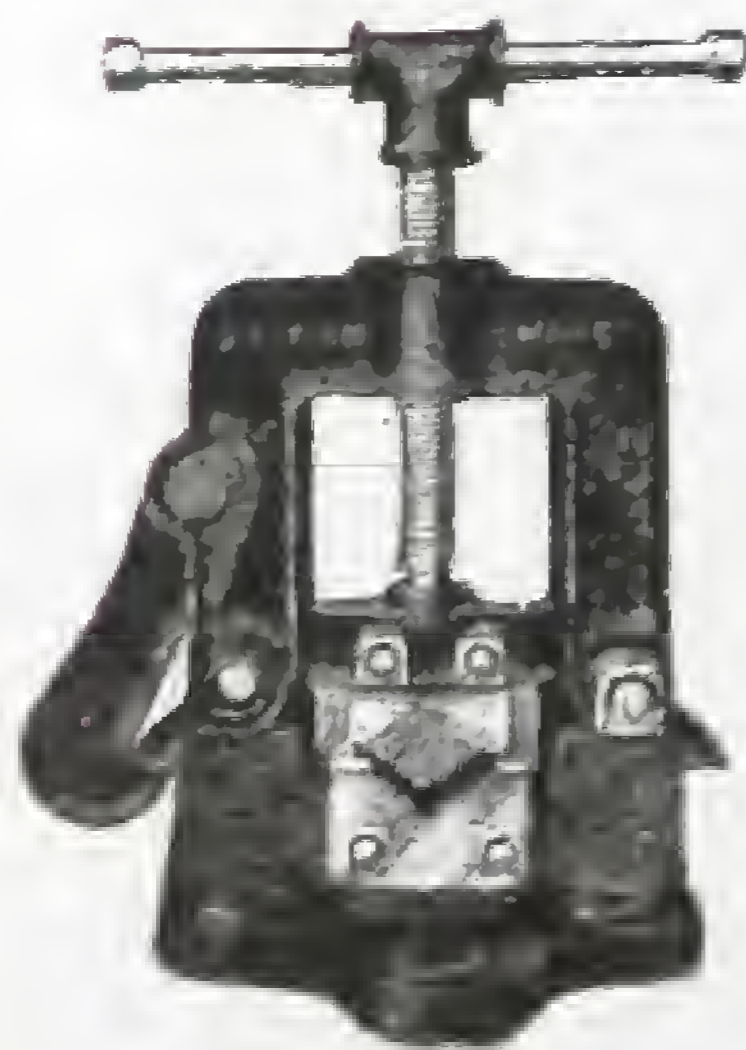

No. M 1295

SELF-LOCKING HINGED PIPE VICE

Best Malleable Iron, fitted with Steel Screw. Jaws machined from Tool Steel and carefully hardened and tested. Frame is reversible and Vice can be operated either Right or Left-Hand. All parts are interchangeable.

Size	Will Grip Pipes	Approx. Weight
AA	½ to 1½ in.	5 lbs.
AB	¾ to 2 in.	7½ lbs.
A	1 to 2½ in.	10 lbs.
B	1½ to 3½ in.	16 lbs.
C	2 to 4½ in.	25 lbs.

TOOLS

FOOTPRINT TUBE VICE

- No. M 526 To hold Pipes $\frac{1}{8}$ to $\frac{3}{4}$ in.
- No. M 384 „ „ „ $\frac{1}{8}$ to $1\frac{1}{2}$ in.
- No. M 385 „ „ „ $\frac{1}{2}$ to 3 in.

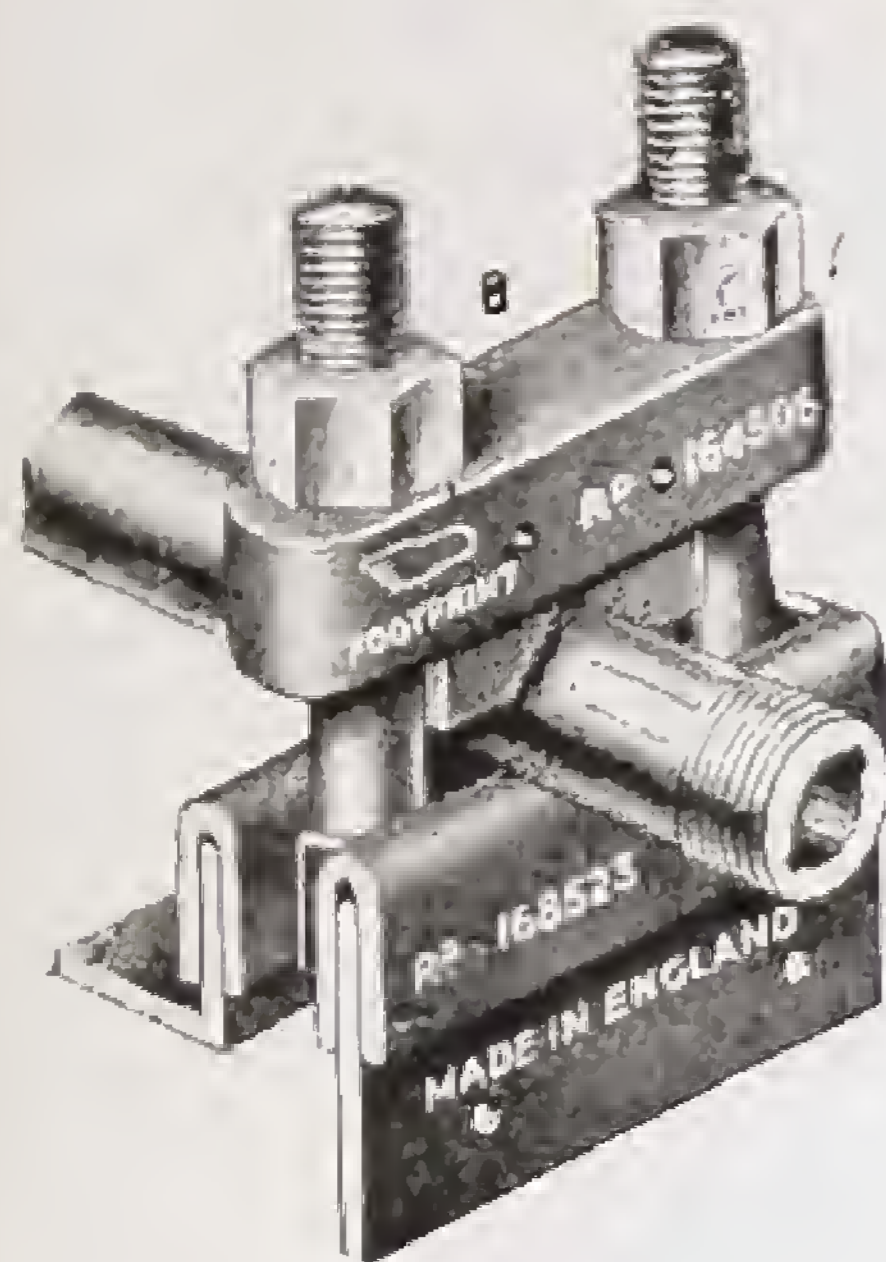

No. M 1296

DROP-FORGED CHAIN VICE

Size

- A To hold pipes $\frac{1}{8}$ to 2 in.
- B „ „ „ $\frac{1}{4}$ to 4 in.
- C „ „ „ $\frac{1}{2}$ to 6 in.
- D „ „ „ $\frac{1}{2}$ to 8 in.



No. M 386

PORTABLE AND COLLAPSIBLE VICE STAND

A new and improved Stand of great strength.

The unique feature of this Stand is the metal floor which gives it exceptional stability and affords a firm foothold.

The extending leg enables it, when collapsed, to stand erect.

Stove enamelled blue.

- Weight 50 lbs.
- Overall height 46 in.
- „ width 30 in.
- Height of Stand only 36 in.



Can be fitted with Hinged Vice similar to M1295, shown on page 394, for Tubes $\frac{1}{8}$ to 2 in.

TOOLS

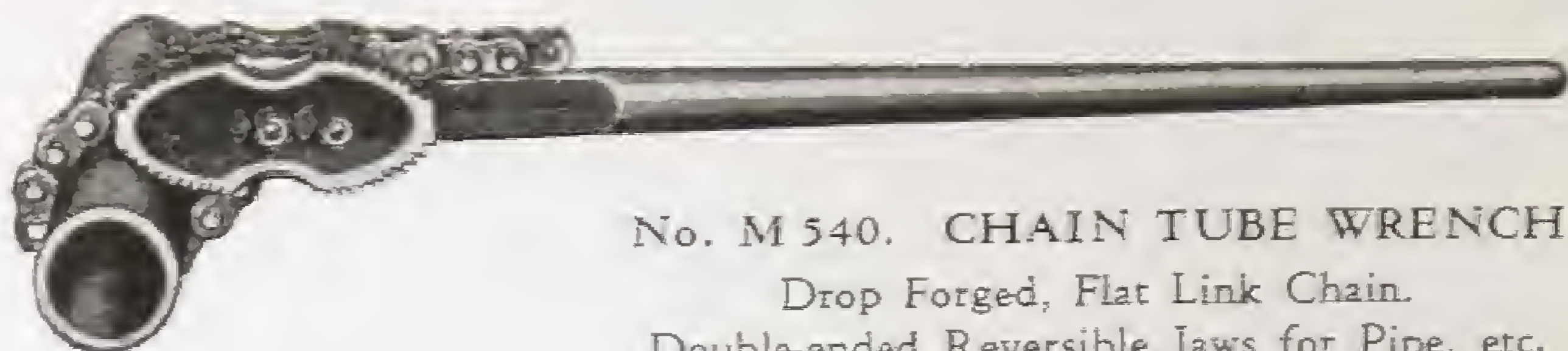

No. M 540. CHAIN TUBE WRENCH

Drop Forged, Flat Link Chain.

Double-ended Reversible Jaws for Pipe, etc.

All parts made of Wrought Steel and interchangeable. The Chain swings from centre, and can be used on either side of the Jaws.

Sizes	30	31	32	33	33½
Size of Pipe	⅛ to ¾	⅛ to 1½	¼ to 2½	¾ to 4	1 to 6 in.

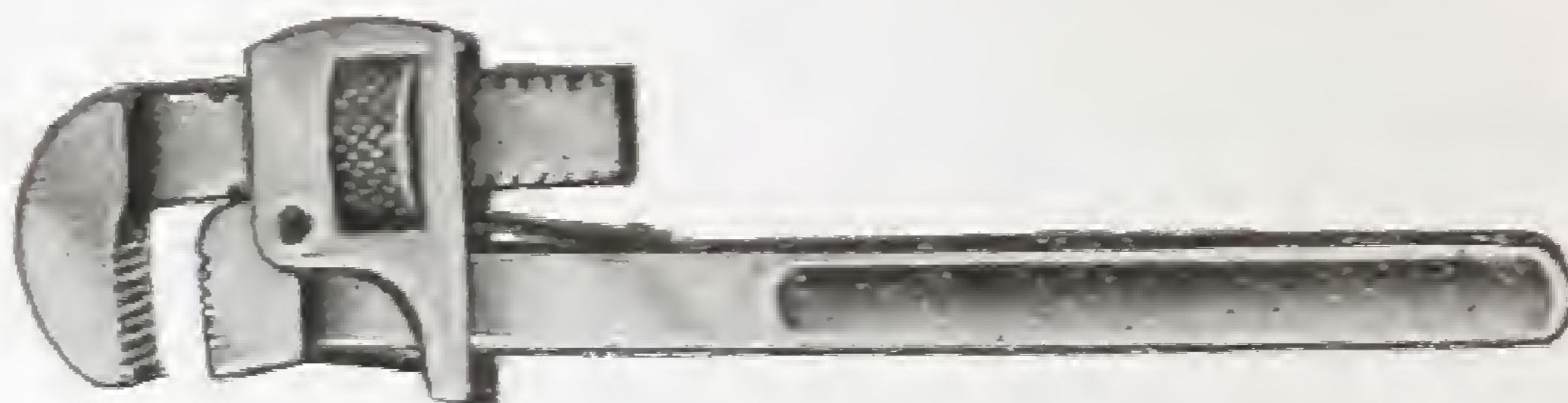

No. M 537. STILLSON TUBE WRENCH

Grips firmly—Square, Hexagon, or almost any irregular shaped piece.

STEEL HANDLE

Length open	...	8	10	14	18	24	36	48 in.
Takes Pipes	...	⅛ to ¾	⅛ to 1¼	¼ to 1¾	¼ to 2½	¼ to 3	½ to 4	1 to 5 in.

No. M 537 A. Similar to above. foreign.

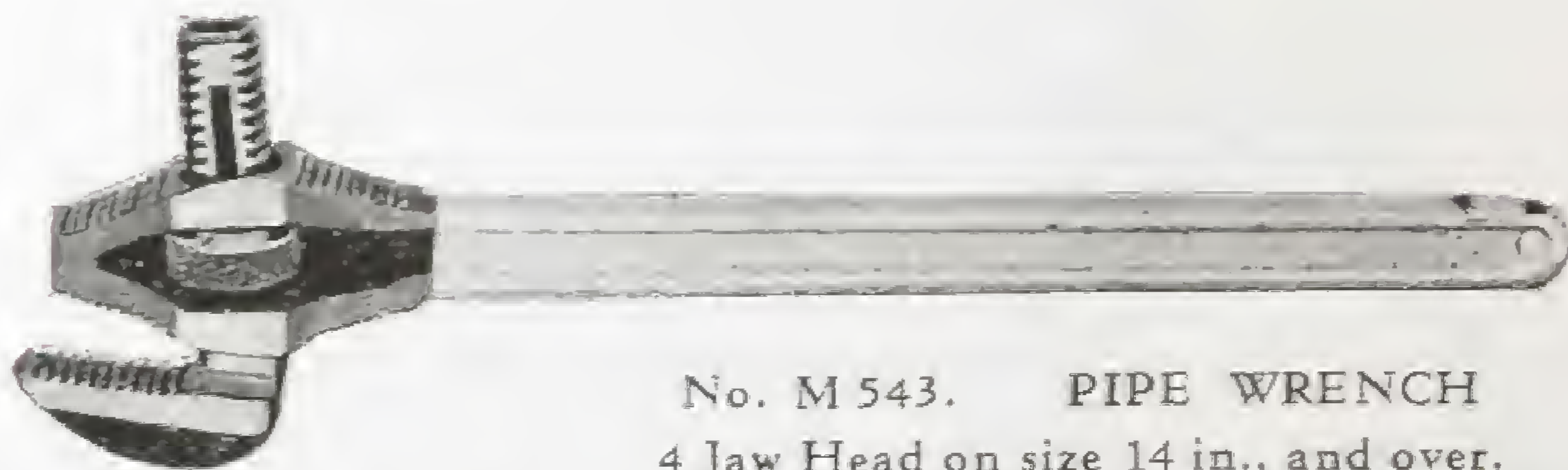

No. M 543. PIPE WRENCH

4 Jaw Head on size 14 in., and over.

The end opening jaws make it possible to slip it straight on to a pipe like a pair of pliers. No need to have space to hook this wrench around a pipe. It works in corners where other types of pipe wrenches will not go, and in open work its firm positive grip inspires confidence to the user.

Sizes	10	14	18	24 in.
Takes Pipe to	1	1½	2	2½ ..

TOOLS

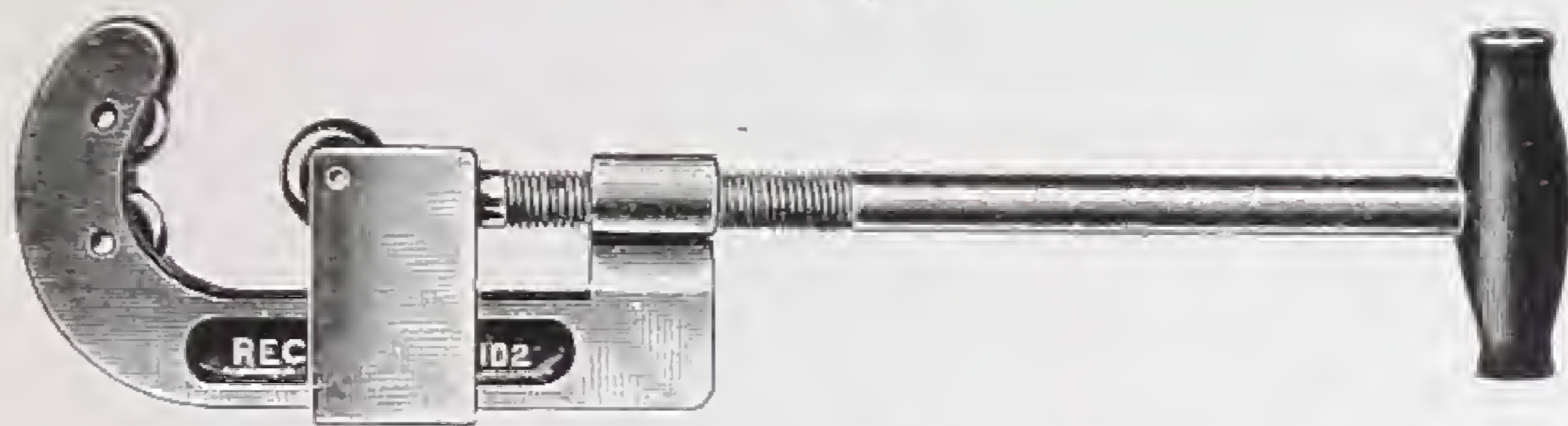

No. M 515. THREE WHEEL TUBE CUTTER

Will cut the tube with one-third of a revolution; specially suitable for cutting fixed tubing in difficult places.

Sizes	1	2	3	4
To cut Tube	...	$\frac{1}{8}$ to 1 in.	$\frac{1}{2}$ to 2 in.	$1\frac{1}{2}$ to 3 in.	$2\frac{1}{2}$ to 4 in.

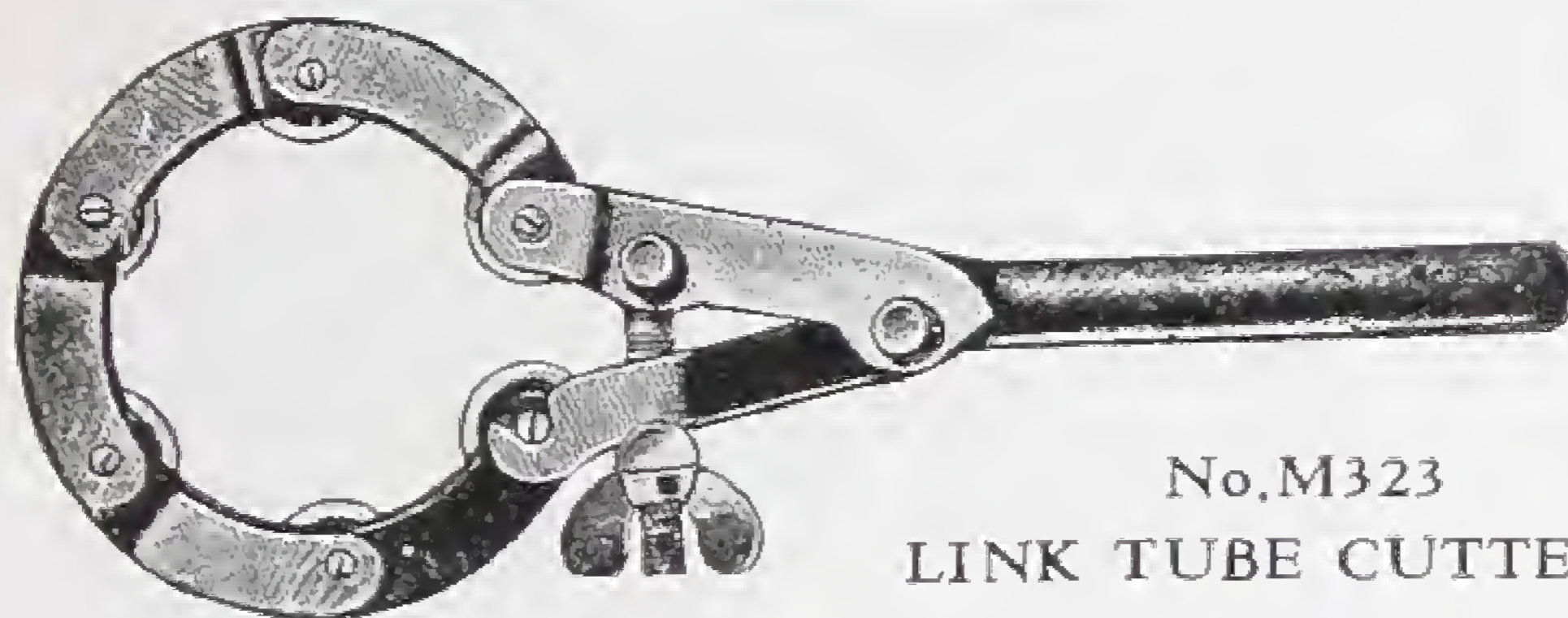

**No. M 323
LINK TUBE CUTTER**

Sizes	A	B	C	D	E	F
No. of Wheels		5	6	7	8	9	10
To cut Tube		2 to 3 in.	2 to 4 in.	2 to 5 in.	2 to 6 in.	2 to 7 in.	2 to 8 in.

Larger sizes on Application. Extra Wheels and Pins can be supplied.

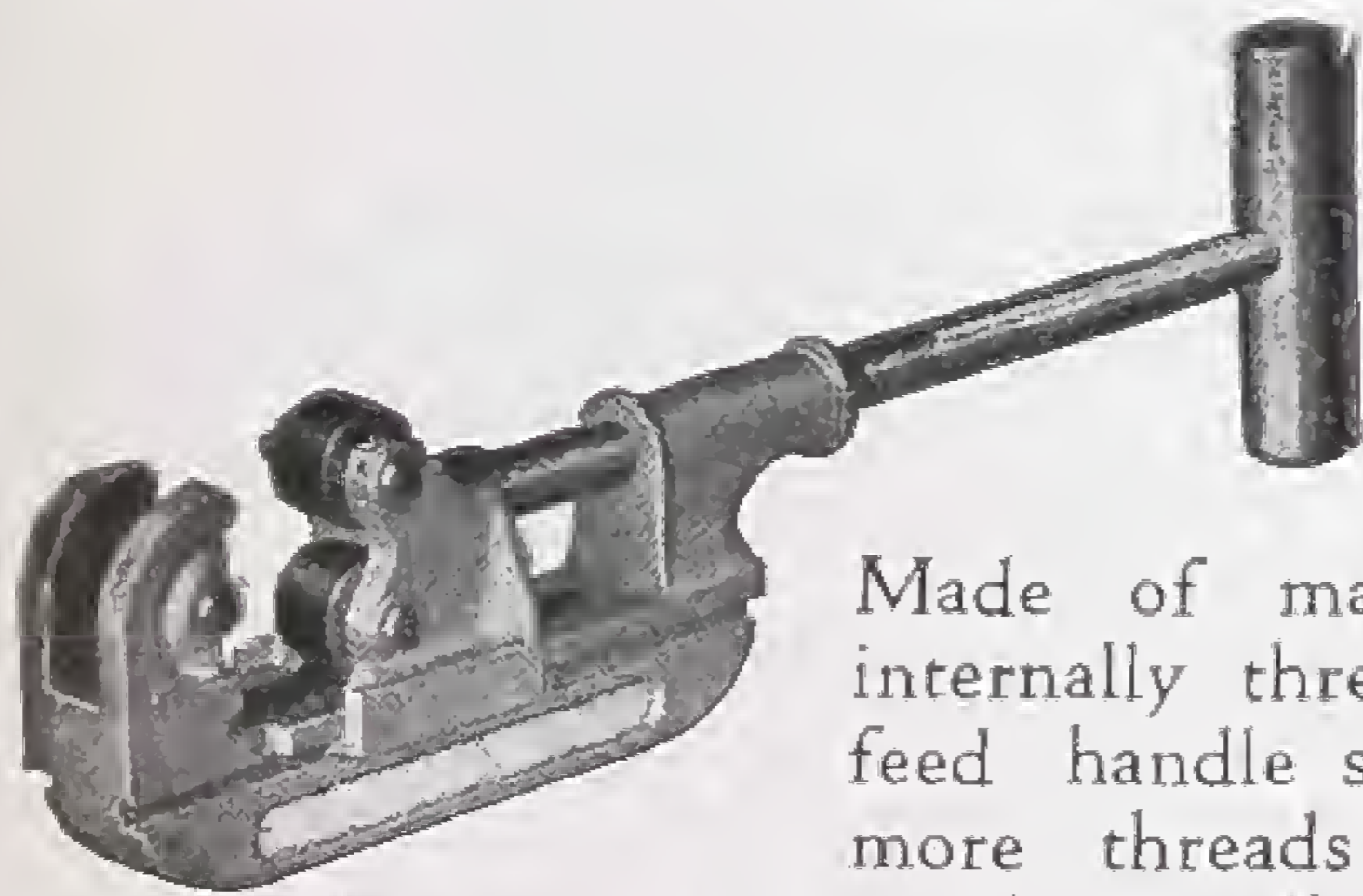

**No. M 410
TUBE CUTTER**

Will cut Tubes $\frac{1}{8}$ in. to 2 in. inclusive.

Made of malleable iron—extra strong. The internally threaded section through which the feed handle screws is made extra long, giving more threads for greater durability. The cross-handle is large enough to afford a comfortable grip. The thin cutter wheel is made of a special grade of alloy steel, electrically heat-treated for durability, and makes a practically burless cut. With One Wheel and Two Rollers.

**No. M 411
LEAD PIPE
CUTTER**

Cuts up to 1 in. pipe.



PATENT SAFETY EXTENSION LADDERS

No. IR 3452

Every Ladder is carefully Tested before Dispatch.

TWO-SECTION LADDERS—Varnished.
Without Rope Attachment.

Ref. Letter	Size	Height Closed	Extends to
O ...	16 rungs ...	6 ft. 9 in. ...	11 ft. 3 in.
D ...	18 ,, ...	7 ft. 3 in. ...	13 ft. 0 in.
E ...	20 ,, ...	8 ft. 0 in. ...	14 ft. 6 in.

With Rope and Pulley Attachment.

Ref. Letter	Size	Height Closed	Extends to
F ...	24 rungs ...	9 ft. 6 in. ...	17 ft. 6 in.
G ...	28 ,, ...	11 ft. 0 in. ...	20 ft. 6 in.
H ...	32 ,, ...	12 ft. 6 in. ...	22 ft. 3 in.
I ...	36 ,, ...	14 ft. 0 in. ...	25 ft. 3 in.
J ...	40 ,, ...	16 ft. 0 in. ...	29 ft. 0 in.
K ...	48 ,, ...	18 ft. 0 in. ...	33 ft. 6 in.

THREE-SECTION LADDERS—Varnished.

Ref. Letter	Size	Height Closed	Extends to
L ...	50 rungs ...	13 ft. 6 in. ...	33 ft. 6 in.
M ...	59 ,, ...	15 ft. 6 in. ...	40 ft. 3 in.
N ...	68 ,, ...	18 ft. 0 in. ...	46 ft. 3 in.



THE PATENT SAFETY COMBINED STEP AND EXTENSION LADDERS

Stained and Varnished

No. IR 3453

Ref. Letter	No. of Steps as Step Ladder	No. of Steps in Ladder	Height of Ladder Closed	Height of Ladder Extended
A ...	5 ...	9 ...	4 ft. 3 in. ...	6 ft. 6 in.
B ...	6 ...	11 ...	5 ft. 0 in. ...	8 ft. 3 in.
C ...	7 ...	13 ...	6 ft. 0 in. ...	10 ft. 0 in.
X ...	8 ...	15 ...	6 ft. 9 in. ...	11 ft. 6 in.
Y ...	9 ...	17 ...	7 ft. 6 in. ...	13 ft. 0 in.
Z ...	10 ...	19 ...	8 ft. 7 in. ...	15 ft. 0 in.

Note.—The top section of Ladder K, and all three sections of Ladders M and N, have a Steel Cable inserted in the back. This adds greatly to the rigidity of the Ladder; for this no extra charge is made.



**WIRE GUARDS
GALVANIZED**



No. IR 2618
Straight Mesh

Cross (Horizontal)
Wires 4 in. apart,
Cross Wires and Selvage
(or Frame) two gauges stronger
than Vertical Wires.

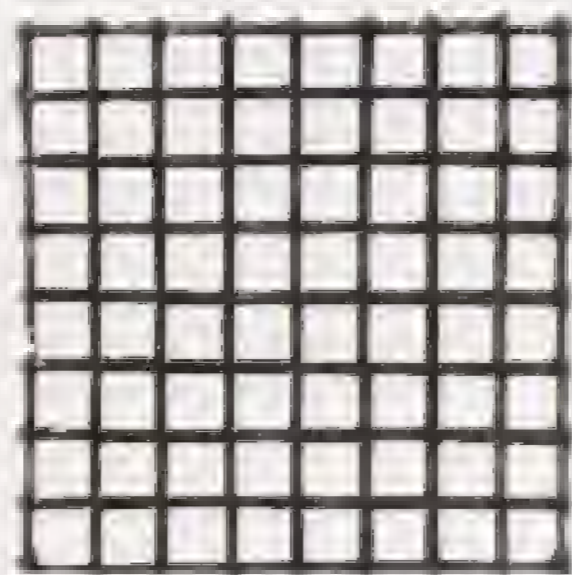

No. IR 2619

Square Mesh
Frame or Selvage two
gauges stronger than in-
terior wires.



No. IR 2620

Diamond Mesh.
Frame or Selvage two
gauges stronger than in-
terior wires.

When ordering, please state which measurement is the Height.

No. IR 2625.

WIRE SNOW GUARDS

Extra strong. Galvanized after made.
Prevents snow from falling from the roof on
to Greenhouses and Sky lights, or breaking
down Guttering, etc.

Made in 6 ft. lengths, 9 in. or 12 in. high
1 in. mesh by No. 12 Gauge Wire, $\frac{1}{2}$ in.
Iron Frame.

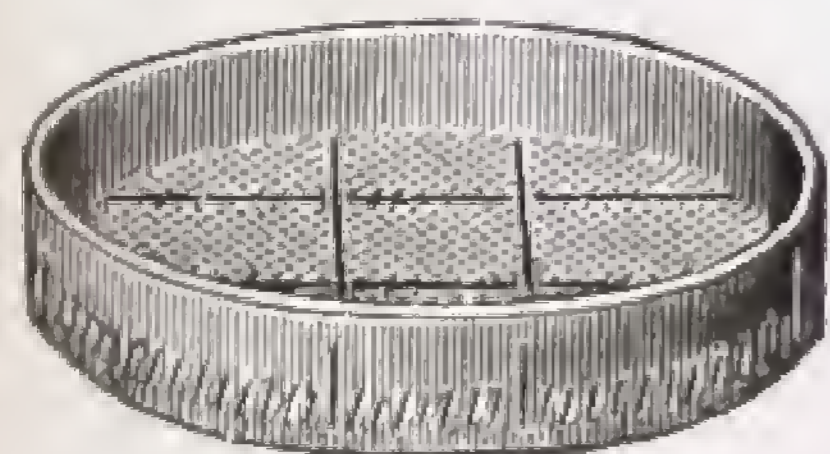
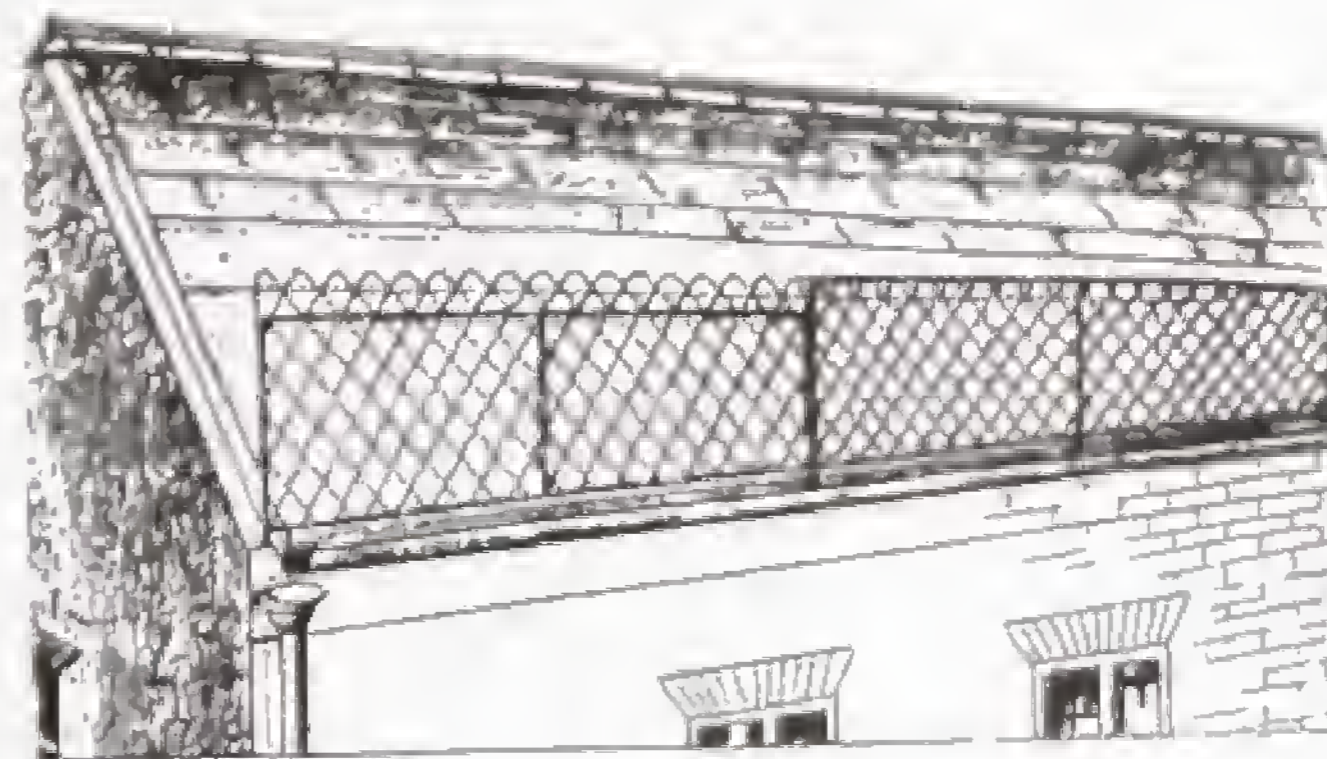

No. IR 2769
STEEL WIRE RIDDLES
With Hardwood Rims.

Sizes : Diameter, 16, 18, 20, 22 and 24 in.
In Mesh $\frac{1}{8}$, $\frac{3}{16}$, $\frac{1}{4}$, $\frac{5}{16}$, $\frac{3}{8}$, $\frac{1}{2}$ in. and upwards.

No. IR 2770
WOVEN WIRE MESH SIEVES

With Hardwood Rims.
Steel Wire 18 in. Diameter.
8s, 10s, 12s and 16s Mesh.
Copper Wire 18 in. Diameter.
8s, 10s, 12s and 16s Mesh.

No. IR 5897
PUNCHEON WIRE MESH

in Pieces 18 x 24 in.
5 or 10 holes to Lineal Inch.
For Plasterers' Puncheon Sieves.

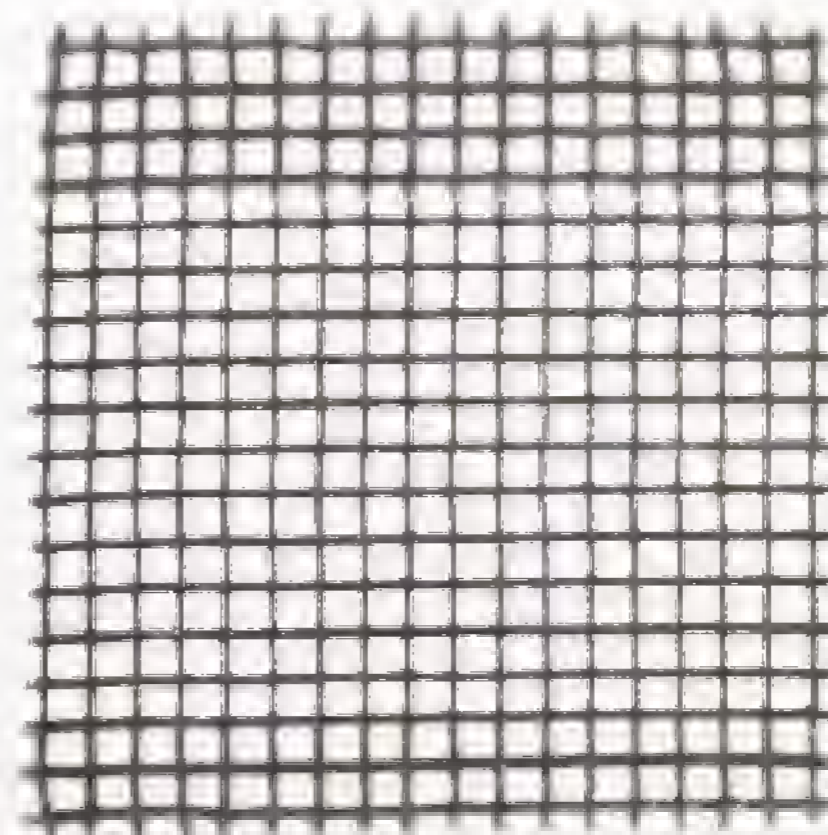

NUMERICAL INDEX

Prefix A—DOMESTIC IRONMONGERY DEPARTMENT

FIG. NO.	PAGE	FIG. NO.	PAGE	FIG. NO.	PAGE	FIG. NO.	PAGE
A3872	87	A3921	87	A5973	63	A5975	60
A3878	87	A3922	87	A5974	63	A5976	60
A3920	87	A5972	63				

Prefix AG—AGRICULTURAL DEPARTMENT

FIG. NO.	PAGE
AG4252E	275

Prefix B—BRASS DEPARTMENT

FIG. NO.	PAGE	FIG. NO.	PAGE	FIG. NO.	PAGE	FIG. NO.	PAGE
B115	126	B314	134	B658	138	B829	156
B160	126	B315	134	B659	138	B830	156
B161	126	B316	134	B661	135	B831	156
B209	126	B317	135	B670	135	B832	156
B227	126	B318	135	B690	135	B833	156
B228	126	B319	135	B691	138	B835	155
B229	126	B330	134	B692	138	B836	155
B230	126	B352	135	B715	130	B837	156
B235	127	B367	145	B716	130	B838	156
B236	127 & 142	B370	138	B717	130	B839	156
B239	127	B371	138	B718	130	B840	156
B241	127	B382	142	B719	130	B841	151
B261	140	B383	143	B759	147	B846	155
B262	139	B386	144	B760	148	B847	147
B263	139	B417	141	B761	148	B848	147
B264	139	B418	143 & 146	B772	149	B850	155
B265	139	B419	141	B773	149	B853	154
B266	134	B454	144 & 146	B774	148	B857	151
B267	135	B456	145 & 147	B775	148	B865	151
B268	140	B591	52	B778	149	B866	151
B269	140	B592	61	B779	149	B867	151
B285	136	B601	131	B781	147	B872	151
B286	136	B602	131	B783	144-145 & 147	B874	151
B287	136	B603	128			B875	151
B288	136	B604	128	B786	144-145 & 147	B879	150
B289	136	B605	131			B881	150
B290	136	B606	131	B799	147	B882	150
B291	136	B611	146	B804	149	B883	150
B292	137	B612	131	B805	142 & 149	B887	150
B293	137	B615	131	B809	149	B888	150
B294	137	B617	131	B810	149	B890	150
B295	137	B622	146	B812	150	B891	150
B296	137	B623	146	B813	156	B902	152
B297	137	B626	146	B814	156	B904	152
B298	137	B627	129	B815	156	B906	152
B299	137	B628	129	B817	156	B907	152
B310	134	B629	129	B825	155	B909	153
B312	134	B650	130	B826	148	B911	153
B313	134	B657	138	B827	148	B923	153

NUMERICAL INDEX—Continued—

Prefix B—BRASS DEPARTMENT

FIG. NO.	PAGE	FIG. NO.	PAGE	FIG. NO.	PAGE	FIG. NO.	PAGE
B925	153	B1687	108	B2477	80 & 81	B2942	221
B930	154	B1690	108	B2478	80 & 81	B2943	221
B931	154	B1691	108	B2511	86	B2950	106
B932	154	B1692	108	B2512	86	B2951	106
B933	154	B1693	108	B2520	122	B2952	106
B934	154	B1694	108	B2535	122	B2953	106
B945	124	B1695	108	B2545	120	B2956	105
B947	124	B1700	107	B2547	120	B2957	105
B953	151	B1702	107	B2576	123	B2962	105
B954	154	B1703	107	B2577	123	B2965	105
B955	149	B1704	106	B2578	204	B2970	105
B957	154	B1706	106	B2583	124	B2971	105
B958	154	B1707	106	B2585	124	B3070	161
B995	155	B1708	106	B2591	125	B3071	160
B996	155	B1709	105	B2592	124	B3075	162
B997	155	B1710	105	B2593	124	B3080	162
B998	155	B1943	363	B2600	204	B3083	166
B1016	132	B1944	363	B2602	204	B3091	166
B1017	132	B1950	363	B2604	204	B3092	166
B1018	132	B1952	363	B2606	204	B3095	166
B1019	133	B1953	363	B2608	204	B3102	163
B1020	133	B1954	363	B2609	204	B3103	163
B1021	133	B1955	363	B2610	204	B3104	163
B1023	132	B1956	363	B2611	204	B3150	174
B1024	133	B1957	363	B2612	204	B3152	174
B1025	132	B1958	363	B2613	204	B3154	174
B1026	133	B1960	363	B2614	204	B3171	175
B1216	45	B1961	365	B2741	271	B3200	176
B1218	45	B1963	365	B2742	271	B3202	176
B1250	51	B1965	365	B2746	273	B3204	176
B1262	51	B1967	365	B2747	271	B3214	175
B1263	51	B1971	365	B2748	271	B3215	174
B1264	51	B1972	365	B2749	271	B3216	177
B1266	51	B2000	110	B2750	271	B3218	177
B1269	51	B2002	110	B2751	271	B3219	174
B1486	62	B2012	111	B2752	271	B3220	177
B1487	62	B2018	113	B2753	271	B3221	174
B1559	98	B2019	114	B2761	272	B3223	174
B1561	98	B2024	112	B2765	274	B3230	200
B1618	104	B2050	115	B2767	276	B3234	200
B1619	104	B2052	115	B2909	190	B3236	200
B1620	104	B2054	115	B2910	190	B3238	200
B1621	104	B2056	115	B2911	190	B3239	201
B1622	104	B2090	117	B2915	191	B3240	200
B1623	104	B2091	117	B2916	191	B3241	200
B1624	104	B2100	117	B2918	191	B3242	200
B1625	104	B2101	117	B2919	191	B3246	201
B1626	104	B2120	117	B2921	191	B3247	201
B1650	95	B2125	117	B2922	191	B3248	201
B1659	123	B2135	116	B2923	191	B3249	201
B1660	123	B2136	116	B2924	191	B3250	201
B1667	107	B2138	116	B2930	179	B3251	201
B1668	107	B2163	53	B2931	179	B3252	201
B1673	107	B2164	53	B2932	179	B3253	201
B1674	107	B2390	93	B2933	179	B3254	201
B1676	107	B2422	82	B2934	179	B3256	200
B1684	108	B2443	84	B2940	221	B3257	200
B1686	108	B2459	85	B2941	221	B3259	200

NUMERICAL INDEX—Continued

Prefix B—BRASS DEPARTMENT

FIG. NO.	PAGE	FIG. NO.	PAGE	FIG. NO.	PAGE	FIG. NO.	PAGE
B3260	175	B3418	178	B4082	60	B4416	39
B3262	175	B3419	178	B4083	60	B4417	39
B3264	175	B3420	178	B4084	60	B4459	67
B3266	175	B3422	178	B4085	60	B4464	83
B3297	202	B3423	178	B4087	63	B4481	46 & 47
B3298	202	B3424	178	B4089	63	B4483	50
B3299	202	B3473	185	B4092	55	B4484	50
B3300	202	B3474	184	B4093	54	B4485	50
B3301	203	B3476	185	B4094	54	B4486	50
B3302	202	B3477	184	B4107	54	B4487	50
B3303	203	B3478	184	B4116	55 & 176	B4488	50
B3304	202	B3488	164	B4117	55 & 176	B4490	56
B3305	203	B3489	164	B4118	55 & 176	B4491	56
B3306	202	B3498	190	B4119	55 & 176	B4492	56
B3309	202	B3500	190	B4120	55	B4493	56
B3310	202	B3501	190	B4125	55	B4494	56
B3311	203	B3503	190	B4151	62	B4495	56
B3312	202	B3504	190	B4170	62	B4496	56
B3313	203	B3552	188	B4182	64	B4497	56
B3314	203	B3554	188	B4185	63	B4498	56
B3315	203	B3571	186	B4186	64	B4499	56
B3316	203	B3572	186	B4187	64	B4500	57
B3317	202	B3573	187	B4188	64	B4501	57
B3318	203	B3574	187	B4192	66	B4502	57
B3320	203	B3576	187	B4193	66	B4503	57
B3321	203	B3581	187	B4194	66	B4504	57
B3322	177	B3582	187	B4195	65	B4505	57
B3324	177	B3584	187	B4196	65	B4506	57
B3325	202	B3592	187	B4197	65	B4507	57
B3326	177	B3594	189	B4198	65	B4508	57
B3328	177	B3596	189	B4223	62	B4509	57
B3330	178	B3598	189	B4239	90	B4510	57
B3331	178	B3600	188	B4243	109	B4511	57
B3334	178	B3602	186	B4244	109	B4512	57
B3344	178	B3604	189	B4245	109	B4513	57
B3345	183	B3677	176	B4313	22	B4514	57
B3346	183	B3678	176	B4315	23	B4521	68
B3351	180	B4036	69	B4317	25	B4600	272
B3353	179	B4061	67	B4348	91	B4601	272
B3356	180	B4063	59	B4358	68	B4602	272
B3357	180	B4064	59	B4358A	68	B5019	11 & 54
B3359	175	B4065	59	B4365	35	B5020	55
B3361	175	B4066	59	B4372	26	B5021	54
B3374	181	B4067	59	B4373	27	B5041	66
B3380	181	B4068	59	B4374	27	B6008	49
B3386	182	B4069	58	B4376	26	B6250	10
B3388	179	B4070	58	B4380	28	B6251	17
B3389	179	B4071	58	B4381	28	B6253	14 & 15
B3390	179	B4072	58	B4382	30	B6254	34
B3392	182	B4073	58	B4383	30	B6255	88
B3394	182	B4074	58	B4384	31	B6256	35
B3396	182	B4075	58	B4385	31	B6258	90
B3400	181	B4076	58	B4386	31	B6259	93
B3413	181	B4077	58	B4387	29	B6260	72 & 73
B3414	181	B4078	58	B4388	29	B6260A	72 & 73
B3415	181	B4079	58	B4389	29	B6261	72 & 73
B3416	178	B4080	60	B4390	86	B6261A	72 & 73
B3417	178	B4081	60	B4413	39	B6261B	72 & 73

NUMERICAL INDEX—Continued

Prefix B—BRASS DEPARTMENT

FIG. NO.	PAGE	FIG. NO.	PAGE	FIG. NO.	PAGE	FIG. NO.	PAGE
B6262	42	B6301	36	B6327	10 12 & 13	B6359	85
B6263	43	B6302	42	B6328	10	B6360	70 & 71
B6264	43	B6303	44	B6329	11	B6361	70 & 71
B6265	42	B6304	44	B6330	11	B6362	76 & 77
B6266	43	B6305	44	B6331	18	B6363	76 & 77
B6267	43	B6306	38	B6332	18	B6365	119
B6268	82	B6307	38	B6333	19	B6366	119
B6269	78 & 79	B6308	38	B6334	19	B6367	121
B6270	78 & 79	B6309	40	B6335	20	B6368	121
B6271	78 & 79	B6310	40	B6336	21	B6369	121
B6272	78 & 79	B6311	41	B6345	88	B6370	120
B6273	69	B6312	41	B6346	89	B6371	120
B6275	91	B6313	48	B6347	89	B6372	122
B6290	273	B6314	46 & 47	B6348	92	B6373	86
B6291	364	B6315	46 & 47	B6349	92	B6374	74 & 75
B6292	364	B6316	45	B6350	98	B6375	74 & 75
B6293	364	B6317	10	B6351	99	B6378	125
B6294	32	B6318	11	B6352	99	B6379	125
B6295	33	B6320	156	B6353	99	B6380	125
B6296	33	B6321	156	B6354	94	B6381	125
B6297	37	B6323	14 & 15	B6355	118	B6382	125
B6298	37	B6324	14 & 15	B6356	118	B6383	125
B6299	34	B6325	10 12 & 13	B6357	83	B6384	125
B6300	36	B6326	10 12 & 13	B6358	84	B6385	53

Prefix BM—BUILDERS' MATERIALS DEPARTMENT

FIG. NO.	PAGE	FIG. NO.	PAGE	FIG. NO.	PAGE	FIG. NO.	PAGE
BM100	244	BM102	244	BM106	252	BM107	252
BM101	244	BM103	244				

Prefix DG—DECORATIVE GLASS DEPARTMENT

FIG. NO.	PAGE	FIG. NO.	PAGE	FIG. NO.	PAGE	FIG. NO.	PAGE
DG21	334	DG33	336	DG477	331	DG489	332
DG22	334	DG34	336	DG478	331	DG490	332
DG23	334	DG35	336	DG479	331	DG491	332
DG24	334	DG36	336	DG480	331	DG492	332
DG25	334	DG37	336	DG481	330	DG493	332
DG26	334	DG38	336	DG482	330	DG494	332
DG27	335	DG39	337	DG483	330	DG495	332
DG28	335	DG40	337	DG484	330	DG496	332
DG29	335	DG41	337	DG486	330	DG497	332
DG30	335	DG42	337	DG487	332	DG498	332
DG31	335	DG476	331	DG488	332	DG499	332
DG32	335						

NUMERICAL INDEX—Continued

Prefix EH—ELECTRICAL DEPT.

FIG. NO.	PAGE	FIG. NO.	PAGE	FIG. NO.	PAGE	FIG. NO.	PAGE
EH883	165	EH888	165	EH901	165	EH907	165
EH884	165	EH889	165	EH902	165	EH908	165
EH885	165	EH890	165	EH903	165	EH909	165
EH886	165	EH891	165	EH904	165	EH910	165
EH887	165	EH900	165	EH905	165	EH911	165

Prefix EX—EXPORT DEPT.

FIG. NO.	PAGE	FIG. NO.	PAGE	FIG. NO.	PAGE	FIG. NO.	PAGE
EX81	101	EX1346	103	EX1400	102	EX4071	101
EX1333	102	EX1350	103	EX1627	103	EX4074	100
EX1334	102	EX1373	102	EX1651	103	EX4075	100
EX1338	103	EX1374	102	EX4070	100	EX5003	103

Prefix F—MIRRORS DEPT.

FIG. NO.	PAGE	FIG. NO.	PAGE	FIG. NO.	PAGE
F2778	67	F2794	67	F2795	67

Prefix FA—FANCY DEPT.

FIG. NO.	PAGE	FIG. NO.	PAGE
FA302	291	FA303	291

Prefix G—OIL & GAS APPLIANCES DEPT.

FIG. NO.	PAGE	FIG. NO.	PAGE	FIG. NO.	PAGE	FIG. NO.	PAGE
G106	205	G237	208	G289A	209	G664	208
G107	205	G238	208	G291	209	G665	208
G152	207	G246	205	G291A	209	G666	208
G154	207	G247	205	G292	209	G756	211
G171	205	G248	205	G392	208	G757	211
G175	205	G249	205	G293	208	G817	210
G179	205	G250	205	G355	208	G1006	208
G193	205	G251	205	G393	210	G1007	208
G197	205	G258A	209	G393A	210	G1023	207
G198	205	G259	209	G394	210	G1024	207
G211	206	G260	209	G409	210	G1092	207
G212	206	G262	209	G413	210	G1095	207
G215F	207	G263	209	G420	210	G1096	207
G216M	207	G267	209	G601	214	G1097	207
G221	208	G272	207	G646	211	G1112	206
G224	208	G274A	205	G647	211	G1113	206
G225	208	G274	205	G648	211	G1127	210
G226	208	G276	206	G649	211	G1127A	210
G233	206	G279	206	G660	208	G7503	214
G234	208	G282	207	G661	208	G5808A	211
G234A	208	G287	208	G662	208	G5808A	211
G237A	208	G289	209	G663	208	G5891	231

NUMERICAL INDEX—Continued—

Prefix G—OIL & GAS APPLIANCES DEPT.

FIG. NO.	PAGE	FIG. NO.	PAGE	FIG. NO.	PAGE	FIG. NO.	PAGE
G5892	231	G6977	192	G6992	193	G6996	193
G5895	231	G6978	192	G6993	193	G6997	193
G5896	231	G6983	193	G6994	193	G6999	196
G6960	196	G6986	193	G6995	193	G7503	214
G6963	196	G6987	193				

Prefix GL—GLASS DEPT.

FIG. NO.	PAGE	FIG. NO.	PAGE	FIG. NO.	PAGE	FIG. NO.	PAGE
GL75	322	GL128	320	GL217	358	GL308	315
GL77	322	GL151	324 & 325	GL221	358	GL309	315
GL78	322	GL152	324 & 325	GL222	358	GL310	315
GL79	322	GL153	324 & 325	GL223	358	GL311	314
GL89	319	GL154	324 & 325	GL224	358	GL312	314
GL90	321	GL155	324 & 325	GL300	320	GL313	314
GL93	320	GL156	324 & 325	GL301	319	GL314	316
GL103	318	GL158	324 & 325	GL302	319	GL315	316
GL104	316	GL159	324 & 325	GL303	317	GL316	316
GL105	318	GL161	324 & 325	GL304	317	GL317	317
GL115	317	GL170	323	GL305	318	GL318	321
GL123	319	GL171	324 & 325	GL306	318	GL319	320
GL124	321	GL172	323	GL307	315		
GL125	321	GL190	323				

Prefix H—HORTICULTURAL DEPT.

FIG. NO.	PAGE	FIG. NO.	PAGE	FIG. NO.	PAGE	FIG. NO.	PAGE
H67	292	H1028	249	H1043	250	H1094	252
H1000	362	H1029	249	H1056	252	H1095	252
H1001	362	H1030	249	H1057	252	H1096	252
H1003	362	H1031	249	H1074	251	H1107	250
H1004	362	H1033M	250	H1075	251	H1108	250
H1012	250	H1035	251	H1082	252	H1109	247
H1014	248	H1036	251	H1083	251	H1110	246
H1018	248	H1039	252	H1084	251	H1150	255
H1019	248	H1040	252	H1086	251	H3392	292
H1026	248	H1042	250	H1093	252	H3395	292
H1027	249						

Prefix IR—IRONMONGERY DEPT.

FIG. NO.	PAGE	FIG. NO.	PAGE	FIG. NO.	PAGE	FIG. NO.	PAGE
IR2091	242	IR2619	399	IR2770	399	IR3453	398
IR2267	242	IR2620	399	IR2799	228	IR5897	399
IR2268	242	IR2625	399	IR2837	353	IR5900	343
IR2618	399	IR2769	399	IR3452	398		

— NUMERICAL INDEX—Continued —

Prefix L—FELTS & CISTERNS DEPT.

FIG. NO.	PAGE	FIG. NO.	PAGE	FIG. NO.	PAGE	FIG. NO.	PAGE
L301	230	L309	230	L381	253	L392	253
L302	230	L310	230	L383	253	L395	253
L303	230	L354	270	L384	253	L396	253
L304	230	L356	270	L387	253	L397	253
L305	230	L357	270	L389	253	L398	253
L307	230	L380	253	L390	253	L399	253
L308	230						

Prefix M—MACHINERY & TOOLS DEPT.

FIG. NO.	PAGE	FIG. NO.	PAGE	FIG. NO.	PAGE	FIG. NO.	PAGE
M8C	375	M570	377	M1369	371	M1443	366
M17	382	M571	377	M1380	373	M1450	366
M23	382	M572	377	M1382	373	M1456	366
M27	382	M589	381	M1383	373	M1460	366
M28	382	M964	374	M1389	367	M1463	366
M186	394	M965	374	M1395	372	M1465	376
M197A	369	M1112A	375	M1397A	367	M1511A	392
M202	357 & 378	M1112B	375	M1397B	367	M1518	375
M210	382	M1113	375	M1398	373	M1530	392
M245	373	M1190	378	M1401	371	M1531	392
M252	368	M1192	381	M1401A	371	M1594	370
M271	381	M1194	369	M1403	371	M1595	370
M276	374	M1198	369	M1404	371	M1629	394
M280	374	M1206	383	M1405	371	M1637	379
M323	397	M1222	378	M1407	372	M1638	379
M383	274	M1224	377	M1408	372	M1639	379
M384	395	M1226	358	M1409	372	M1642	379
M385	395	M1229	368	M1410	372	M1648	377
M386	395	M1232	373	M1411	372	M1648A	377
M392	369	M1237	373	M1412A	376	M1686A	387
M393	377	M1271	384	M1412B	376	M1686B	387
M397	378	M1274	383	M1413A	376	M1693	367
M398	378	M1292	393	M1413B	376	M1695	367
M399	274	M1295	394	M1414A	376	M1700A	370
M401	378	M1296	395	M1414B	376	M1710A	371
M402A	375	M1300	377	M1415	358	M1773	368
M403	375	M1310	375	M1416	376	M1792	366
M410	397	M1311	375	M1417A	376	M1793	366
M411	397	M1321	379	M1417C	376	M1915	385
M413	368	M1322	379	M1418B	376	M1916	381
M515	397	M1350	367	M1419	387	M1917	393
M526	395	M1352	370	M1421A	376	M1918	393
M532	368	M1357	370	M1433	366	M1919	393
M533	368	M1357A	370	M1435	366	M1920	380
M537	396	M1358	370	M1436	366	M1921	380
M537A	396	M1359	370	M1441	366	M1922	380
M540	396	M1364	370	M1442	366		
M543	396						

NUMERICAL INDEX—Continued

Prefix P—PAINT DEPT.

FIG. NO.	PAGE	FIG. NO.	PAGE	FIG. NO.	PAGE	FIG. NO.	PAGE
P155	360	P387	355	P617	342	P730	341
P300	354	P407	355	P618	342	P860	346
P307	354	P411	355	P632	342	P861	343
P310	354	P413	355	P633	342	P875	360
P326	354	P441	357	P634	342	P876	360
P328	354	P450	357	P635	342	P881	360
P336	354	P492	357	P636	342	P882	360
P340	354	P496	357	P637	342	P885	361
P342	354	P500	357	P638	342	P886	361
P354	354	P536	353	P640	342	P891	361
P374	355	P556	353	P641	342	P905	361
P377	355	P568	353	P643	342	P931	61
P379	355	P570	353	P645	342	P932	343
P381	355	P579	339	P650	342	P933	61
P383	355	P580	339	P710	341	P934	61
P385	355	P581	339	P711	341	P935	61

Prefix R—RANGE DEPT.

FIG. NO.	PAGE
R100	362

Prefix R—RAINWATER DEPT.

FIG. NO.	PAGE	FIG. NO.	PAGE	FIG. NO.	PAGE	FIG. NO.	PAGE
R83	258 & 259	R116	258 & 259	R172	261	R212	262
R84	258 & 259	R117	258 & 259	R173	261	R213	262
R85	258 & 259	R118	258 & 259	R174	261	R215	262
R86	258 & 259	R119	258 & 259	R175	261	R216	262
R87	258 & 259	R120	258 & 259	R176	261	R217	262
R88	258 & 259	R121	258 & 259	R177	261	R218	262
R89	258 & 259	R122	258 & 259	R178	261	R225	263
R90	258 & 259	R123	258 & 259	R179	261	R235	263
R91	258 & 259	R127	260	R180/1	261	R236	263
R92	258 & 259	R128	260	R182	261	R237	263
R93	258 & 259	R129	260	R184	261	R238	263
R94	258 & 259	R130	260	R185	261	R243	263
R95	258 & 259	R132	260	R186	261	R244	263
R96	258 & 259	R133	260	R187	261	R245	263
R97	258 & 259	R134	260	R190	261	R250	263
R98	258 & 259	R135	260	R191	261	R251	263
R99	258 & 259	R136	260	R192	261	R252	263
R100	258 & 259	R137	260	R193	261	R253	263
R101	258 & 259	R141	258 & 259	R195	261	R254	263
R102	258 & 259	R142	258 & 259	R196	261	R255	263
R104	258 & 259	R143	258 & 259	R197	261	R256	263
R105	258 & 259	R144	258 & 259	R200	262	R257	263
R106	258 & 259	R145	258 & 259	R201	262	R258	263
R107	258 & 259	R146	258 & 259	R202	262	R259	263
R108	258 & 259	R147	258 & 259	R203	262	R260	263
R109	258 & 259	R148	258 & 259	R204	262	R308	268 & 269
R110	258 & 259	R149	258 & 259	R205	262	R309	268 & 269
R112	258 & 259	R149A	258 & 259	R206	262	R310	268 & 269
R113	258 & 259	R149B	258 & 259	R207	262	R314	268 & 269
R114	258 & 259	R170	261	R208/9	262	R315	268 & 269
R115	258 & 259	R171	261	R210/1	262	R317	268 & 269

NUMERICAL INDEX—Continued

Prefix R—RAINWATER DEPT.

FIG. NO.	PAGE	FIG. NO.	PAGE	FIG. NO.	PAGE	FIG. NO.	PAGE
R318	268 & 269	R341	268 & 269	R678	266	R780	266
R319	268 & 267	R342	268 & 269	R759	266	R781	266
R320	268 & 267	R356	268 & 269	R760	266	R782	266
R321	268 & 269	R357	268 & 269	R761	266	R783	266
R322	268 & 269	R358	268 & 269	R762	266	R810	264 & 266
R323	268 & 269	R359	268 & 269	R763	266	R813	264 & 266
R324	268 & 269	R360	268 & 269	R764	266	R830	264 & 266
R325	268 & 269	R435	267	R769	266	R832	264 & 266
R329	268 & 269	R436	267	R770	266	R833	264 & 266
R330	268 & 269	R437	267	R771	266	R834	264 & 266
R331	268 & 269	R439	267	R773	266	R835	264 & 266
R335	268 & 269	R447	241	R775	266	R837	264 & 266
R336	268 & 269	R615	264 & 265	R778	266	R925	25
R339	268 & 269	R652	264 & 265	R779	266	R928	25
R340	268 & 269	R656	264 & 265				

Prefix RW—RAINWATER DEPT.

FIG. NO.	PAGE	FIG. NO.	PAGE	FIG. NO.	PAGE	FIG. NO.	PAGE
RW60	197	RW130	197	RW241	197	RW340	19
RW90	197	RW180	197	RW246	197	RW827	19
RW92	197	RW221	197	RW260	197	RW828	19
RW96	197	RW223	197	RW270	197	RW860	19
RW120	197						

Prefix SF—SHOP FITTINGS DEPT.

FIG. NO.	PAGE	FIG. NO.	PAGE	FIG. NO.	PAGE	FIG. NO.	PAGE
SF310	216	SF336	219	SF435	218	SF751	21
SF311	217	SF337	219	SF722	218	SF752	22
SF312	217	SF339	219	SF723	218	SF753	22
SF314	216	SF340	219	SF741	216	SF754	21
SF315	216	SF341	219	SF742	218	SF755	21
SF317	216	SF342	219	SF743	218	SF756	21
SF318	216	SF343	219	SF744	218	SF757	21
SF319	217	SF344	219	SF745	218	SF758	21
SF320	217	SF348	217	SF750	217	SF1000	21
SF331	218	SF354	218			SF1001	21

Prefix V—VENTS & LAMPS DEPT.

FIG. NO.	PAGE	FIG. NO.	PAGE	FIG. NO.	PAGE	FIG. NO.	PAGE
V9	333	V1000	240	V1039	243	V1057	24
V913	333	V1003	240	V1041	243	V1060	24
V920	333	V1015	243	V1044	242	V1064	24
V931	333	V1016	243	V1045	242	V1100	23
V940	333	V1024	241	V1046	242	V1101	23
V954	333	V1025	241	V1049	242	V1103	23
V970	333	V1029	241	V1052	242	V1104	23
V987	332	V1030	241	V1053	243	V1122	24
V999	240	V1031	241				

Prefix WP—WALLPAPER DEPT.

FIG. NO.	PAGE	FIG. NO.	PAGE
WP540	353	WP541	353



INCHES

1

2

3

4

5

6